

ADVERTISEMENT FOR BIDS

Sealed proposals will be received in the Office of the Procurement Manager, Greenville Utilities Commission, 401 S. Greene Street, Greenville, North Carolina 27834 until 2:00 PM (EDT) on June 4, 2026 and immediately thereafter publicly opened and read for the furnishing of approximately:

2 - STK# 205830 TRANSFORMER, 2,000 KVA THREE-PHASE PADMOUNT

Instructions for submitting bids and complete specifications will be available in the Office of the Procurement Manager, Greenville Utilities Commission, 401 S. Greene Street, Greenville, North Carolina during regular office hours, which are 8:30AM – 5:00PM Monday through Friday.

Greenville Utilities Commission reserves the right to reject any or all bids. **Late bids will not be considered.**

SECTION I

GENERAL INSTRUCTIONS FOR FORMAL BIDS

RELATED TO THE PURCHASE OF APPARATUS, SUPPLIES,

MATERIALS, AND EQUIPMENT

JUNE 4, 2026

1.0 NOTICE TO BIDDERS

Sealed bids, subject to the conditions made a part hereof, will be received in the Office of the Procurement Manager, Greenville Utilities Commission, 401 S. Greene Street, Greenville, North Carolina 27834 until 2:00 PM (EDT) on the day of opening. **Bids submitted in a fax or e-mail in response to this Invitation for Bids will not be acceptable. Late Bids will not be considered.**

2.0 STANDARD FORMS REQUIRED

Each bidder must submit a proposal on the enclosed bid forms. **The bid must be signed by an authorized official of the firm. Return only the attached Proposal Form. Do not return the Advertisement for Bids, Instructions to Bidders or Specifications.**

3.0 PREPARATION OF BID

Bids must be in sealed envelopes clearly marked on the outside with the name of the bid and the bid opening date and time. Bid shall be addressed to PROCUREMENT MANAGER, GREENVILLE UTILITIES COMMISSION, 401 S. GREENE STREET, GREENVILLE, NORTH CAROLINA, 27834.

4.0 TIME FOR OPENING BIDS

Bids will be opened promptly and read at the hour and on the date set forth in the advertisement in the Office of the Procurement Manager, Greenville Utilities Main Office, 401 S. Greene Street, Greenville, North Carolina. Bidders or their authorized agents are invited to be present.

5.0 DEPOSIT

A deposit is **NOT** required for this bid.

6.0 NC SALES TAX

Do **not** include NC sales taxes in bid figure; however, Greenville Utilities Commission (GUC) does pay sales tax. Sales tax should be added to the invoice as a separate item.

7.0 FEDERAL EXCISE TAX

GUC is exempt from Federal Excise Tax and will issue a Federal Exemption Certificate upon request to the successful bidder.

8.0 EXCEPTIONS TO BE CLEARLY STATED

If bid is not in strict accordance with Section II, "Specifications," bidder must list or note all exceptions **on the Request for Proposal Form**, otherwise, it is fully understood that the successful bidder will furnish equipment and/or materials exactly as specified. GUC reserves the right to accept or reject bids with noted minor deviations from specifications and to determine the lowest responsible, responsive bid from the standpoint of quality, performance, delivery, and price.

9.0 EVALUATION AND AWARD OF BIDS

GUC reserves the right to reject any and all bids, to waive any and all informalities, and to disregard all nonconforming or conditional bids or counter proposals. In evaluating bids, GUC shall consider whether the bids comply with the prescribed requirements, plus all alternates or options requested. GUC reserves the right to include or exclude any option or alternative in GUC's opinion is in GUC's best interests. If a bid is to be awarded, it will be awarded to the lowest responsible, responsive bidder whose evaluation by GUC indicates that the award will be in GUC's best interests. Only firm prices will be considered for award of this bid.

Award of transformer bids shall be primarily based upon the lowest estimated total ownership cost (TOC) to the Commission using the following currently approved Electricities Transformer Formula. If the total ownership cost difference between the apparent lowest cost unit and any other units is less than 3%, then the Commission has the option to evaluate these units on lowest initial cost and award on this basis, taking into account quoted delivery time. In addition to the estimated TOC, quoted delivery time and past performance of the bidder and/or manufacturer with respect to other bid awards shall be considered in evaluating and awarding bids.

For transformers base rated less than 100 KVA, the following formula will be used:

$$\text{TOC} = \text{Unit Cost} + \$7.80/\text{watt} \times \text{NL Loss} + \$2.10/\text{watt} \times \text{Load Loss}$$

For transformers base rated 100 KVA or greater, the following formula will be used:

$$\text{TOC} = \text{Unit Cost} + \$7.80/\text{watt} \times \text{NL Loss} + \$2.10/\text{watt} \times \text{Load Loss}$$

NOTE: TOC is the Total Ownership Cost for 30 years.
Unit Cost is the base cost of the transformer.
NL Loss is the loss, in watts, at No Load for the transformer.
Load Loss is the Load Loss, in watts, **excluding** no load losses, but **including** breaker losses and any other load related losses.

Bidder shall provide guaranteed **average** no load and load losses as defined under the latest revision of ANSI Standard C57.

10.0 PROMPT PAYMENT DISCOUNTS

Bidders are urged to compute all discounts into the price offered. If a prompt payment discount is offered, it may be considered in the award of the contract.

11.0 NUMERICAL ERRORS

In the case of a discrepancy between a unit price and the extension (the unit price multiplied by the number of units), the unit price governs. In the case where numerical bids are stated both in numbers and in words, the words govern.

12.0 BID WITHDRAWAL

A bidder must notify GUC in writing of its request to withdraw a bid within seventy-two (72) hours after the bid opening, not including Saturdays, Sundays, or holidays. In order to justify withdrawal, the bidder must demonstrate that a substantial error exists and that the bid was submitted in good faith.

13.0 MINORITY BUSINESS PARTICIPATION PROGRAM

GUC has adopted an Affirmative Action and Minority and Women Business Enterprise Plan (M/WBE) Program. Firms submitting a proposal are attesting that they also have taken affirmative action to ensure equality of opportunity in all aspects of employment, and to utilize M/WBE suppliers of materials and/or labor.

14.0 QUANTITIES

Quantities specified are only estimates of GUC's requirements. GUC reserves the right to purchase more or less than the stated quantities at prices indicated in the submitted Proposal Form based on our actual needs.

15.0 DELIVERY

Shipments will be made only upon releases from a purchase order issued by GUC in accordance with GUC's current needs.

Time is of the essence with respect to all deliveries under this Agreement.

Delivery of all equipment, materials, or supplies shall be made Free on Board (FOB) GUC Warehouse, 701 Utility Way, Greenville, North Carolina 27834, unless otherwise specified. The agreed price for such equipment, materials, or supplies shall include all costs of delivery and ownership, and risks of loss shall not be transferred from Provider to GUC until express written acceptance of delivery and inspection by GUC. Delivery hours are between 8:00 AM and 4:30 PM Monday-Friday only. **GUC's purchase order number is to be shown on the packing slip or any related documents.** GUC reserves the right to refuse or return any delivery with no purchase order number or which is damaged. GUC will not be charged a restocking fee for any delivery which is refused or returned.

16.0 DELIVERY TIME

Delivery time is to be stated by the bidder and will be a factor in the evaluation of bids. The ability of a bidder to provide the item(s) to be purchased in twenty (20) weeks or less is essential for GUC to meet its customer requirements.

17.0 MANUFACTURER

Bidder is to specify the manufacturer of transformers being quoted. If requested, bidder shall identify the place of manufacture of all transformers quoted. The successful bidder, on or before the time of shipment, shall furnish the Commission with the catalog number of the transformers bid.

18.0 CONTACT INFORMATION

Questions regarding this bid request should be directed to Cleve Haddock, Lifetime CLGPO, Procurement Manager at (252) 551-1533, haddocgc@guc.com. **All questions regarding this bid must be received by or before 5:00 pm (EDT) on May 12, 2026.**

19.0 TERMS AND CONDITIONS

The attached Terms and Conditions must be considered by all vendors as part of the bid proposal.

[Balance of page left blank intentionally]

Pressure Relief Valve
Dial Type Thermometer for top oil temperature
Straddle Taps with external (to the tank) changer

SECTION II

GREENVILLE UTILITIES COMMISSION

TRANSFORMER SPECIFICATIONS

Description

2,000 KVA Three-Phase Padmount Transformers, three phase 60 Hz, 65°C rise, 95 KV BIL, 12470/7200 volt grounded wye primary to 480Y/277 volt secondary. High voltage section to be dead front radial feed design and be equipped with three high voltage ESNA wells, parking stands, protected with high ampere overload Bay-O-Net oil fuse Cooper #403861C05CB and ELSP current limiting backup fuse Cooper #CBUC08250D100, provided with grounding lugs at bottom of the compartment suitable for 10 #14 copper wires per phase. The minimum dimensions of the secondary compartment are to be 30 inches wide by 30 inches deep. Low voltage terminals are to be tinned copper, 20-hole bushing spade type complete with bracing sufficient to support the conductors during a full magnitude or “bolted” secondary fault and neutral grounding straps. The transformers are to be equipped with the following accessories:

Liquid Level Gauge
Pressure-vacuum Gauge
Pressure Relief Valve
Dial Type Thermometer for top oil temperature
Straddle Taps with external (to the tank) changer

The transformers are to have bolt-on type covers such that tap changer and bushings are accessible. Transformer is to be equipped with pressure relief device and colored green. The coating system of the transformer is to meet all test requirements prescribed in ANSI Standard C57.12.28-1988. (GUC STK# 205830)

[Balance of page left blank intentionally]

NOTES:

Pole Mount Transformers

- (1) Pole mount type distribution transformers, both conventional and CSP, should comply with the following:
 - a. High voltage bushings shall be of porcelain with a threaded bolt type top ("A" thread 5/16"-18) with a wildlife connector cap consisting of a hood and handwheel of sturdy molded glass filled polyester with an eyebolt capacity of 7/16". The hood and handwheel to be standard gray and equipped with a "knockout" slot where lightning arrester leads are required. The wildlife connector cap to be of a type equal to Porcelain Products type (Part No. 65014). See attachment.
 - b. The cover finish should be of a BIL rated material to enhance resistance to wildlife contacts.
 - c. Arresters approved for use on CSP transformers are as follows:

Cooper URT10050X1A1B1A

- (2) Successful manufacturer shall certify each unit as non-PCB at time of manufacture and delivery to Greenville Utilities, to be shown on the name plate.
- (3) Only new transformers will be considered; rebuilt and/or remanufactured transformers are not acceptable and will not be considered.
- (4) Only firm prices will be considered for award of this bid.

All Padmount Transformers

- (1) Padmounted transformers are to be marked with bilingual safety labels in accordance with NEMA Standard 260-1996 and conform to enclosure security requirements per ANSI C57 12.28-4
- (2) Successful manufacturer shall certify each unit as non-PCB at time of manufacture and delivery to Greenville Utilities, to be shown on the name plate.
- (3) Only new transformers will be considered; rebuilt and/or remanufactured transformers are not acceptable and will not be considered.
- (4) Only firm prices will be considered for award of this bid.

Padmount Transformers 750 kVA and Larger

(1) Impedance values for the units listed shall not be less than 4.5%.

DELIVERY TIME: Delivery time is to be stated and will be considered in the evaluation of bids. Failure by the successful bidder to meet quoted delivery shall be interpreted as non-compliance with these specifications and may be deemed sufficient cause for removal of the manufacturer and/or distributor from our lists as acceptable manufacturers or bidders.

MANUFACTURER: Bidder is to specify the manufacturer of transformers being quoted. If requested, bidder shall identify the place of manufacture of all transformers quoted. The successful bidder, on or before the time of shipment, shall furnish the Commission with the catalog number of the transformers bid.

LOSS DATA: Bidder shall provide guaranteed **average** no-load and load losses as defined under the latest version of ANSI Standard C57.12.90 unless otherwise specified.

No-load losses shall be provided at 85°C. Use the following formula and instructions for temperature correction to 85°C:

$$P_{85} = P_c(T_m)[1+(T_m-85)K_T]$$

where,

P_{85} = the no-load losses corrected to 85°C

$P_c(T_m)$ = no-load losses, corrected for waveform, at temperature T_m in °C

K_T = an empirically derived per unit change in no-load loss per °C

If the actual value of K_T is not available, a value of 0.00065 per unit change per °C should be used. This value is typical for cores constructed of grain oriented silicon steel and is satisfactory as a correction for no-load losses over the temperature range normally encountered in transformer testing. The core material to be utilized and the K_T used for temperature correction shall be identified on the proposal form.

Load losses shall be provided at 85°C as described in ANSI Standard C57.12.90-1987, Section 9.4, "Calculation of Impedance Voltage and Load Loss from Test Data." The losses shall include all losses, **excluding** no-load losses.

The winding material for high voltage and low voltage shall be indicated on the proposal form.

METHOD OF AWARD: Each item will be purchased individually.

Award of transformer bids shall generally be based upon the lowest estimated total ownership cost (TOC) to the Commission using the following currently approved Electricities Transformer Formula. If the total ownership cost difference between the apparent lowest cost unit and any other units is less than 3%, then the Commission has the option to evaluate these units on

lowest initial cost and award on this basis. As deemed appropriate by the Commission, in addition to estimated TOC, quoted delivery time and part performance of the bidder and/or manufacturer with respect to other bid awards shall be considered in evaluating and awarding bids.

For transformers base rated less than 100 KVA, the following formula will be used:

$$\text{TOC} = \text{Unit Cost} + \$7.80/\text{watt} \times \text{NL Loss} + \$2.10/\text{watt} \times \text{Load Loss}$$

For transformers base rated 100 KVA or greater, the following formula will be used:

$$\text{TOC} = \text{Unit Cost} + \$7.80/\text{watt} \times \text{NL Loss} + \$2.10/\text{watt} \times \text{Load Loss}$$

NOTE: TOC is the Total Ownership Cost for 30 years.
Unit Cost is the base cost of the transformer.
NL Loss is the loss, in watts, at No Load for the transformer.
Load Loss is the Load Loss, in watts, **excluding** no load losses, but **including** breaker losses and any other load related losses.

Bidder shall provide guaranteed **average** no load and load losses as defined under the latest revision of ANSI Standard C57.

CERTIFIED TEST RESULTS: For the purpose of this bid, the successful bidder must submit certified test results for **each** transformer before shipment can be considered completed and accepted by the Commission. Payments for any shipments will be withheld until certified test results for all transformers associated with that shipment are supplied and accepted by the Commission.

Certified test reports **must** be received by the Commission within five (5) working days of receipt of transformers. Failure to provide test results in a timely manner shall be interpreted as non-compliance with these specifications and may be deemed sufficient cause for removal of the manufacturer and/or distributor from our bid lists as acceptable suppliers.

All transformers in this bid shall be designed, manufactured and tested in accordance with the latest revisions of the applicable ANSI Standards. No transformer supplied shall exceed a **guaranteed maximum** no-load and load losses of 10% of **quoted average** No Load Loss and/or 6% of **quoted average** Total Load Loss, i.e., No Load + Load Loss. Individual transformers exceeding this requirement will not be accepted and will be returned to the manufacturer and/or distributor freight collect.

If either the certified test results or the Commission's own testing of transformers received reveals values exceeding the **quoted average** losses, No Load Loss and/or Load Loss, the Commission will exercise one of the two options listed below:

1. Return any transformers up to and including all of the shipment, C.O.D., to be replaced by the bidder with transformers that meet the quoted losses in the bid, or
2. Invoice, or receive a credit memo from the bidder toward the purchase order issued for

the award, for liquidated damages based upon two (2) times the excess TOC for the total order to be incurred by the Commission in accepting the transformers supplied by the bidder, i.e.,

$$\text{Liquidated Damages} = 2 \times (\text{Delivered TOC} - \text{Quoted TOC})$$

No credit shall be applied toward delivery and acceptance of transformers of an order with a delivered TOC below the quoted TOC.

Payment of all damages by the bidder will be in the form of cash settlement or credit memo to be applied against the purchase order. Substitution of additional transformers or credit toward future purchases will **not** be accepted by the Commission.

In addition, the Commission may, at its option, remove the manufacturer and/or distributor from its approved manufacturer and/or bidder lists until all damages are paid and the Commission is convinced that the manufacturer and/or bidder can meet all performance requirements and other obligations prescribed by the Commission.

MISCELLANEOUS: Aside from compliance with transformer loss requirements, transformers that are found to be damaged upon delivery or fails to otherwise meet all other bid specifications and requirements will not be accepted by the Commission.

ACCEPTABLE TRANSFORMER MANUFACTURERS: The following transformer manufacturers are considered acceptable for this bid:

Power Partners/ABB
Central Moloney
Cooper Power Systems
ERMCO
GE/Prolec
Howard Industries
Kuhlman Electric Company
CG Power Systems
VanTran Industries Inc.
JSHP Transformer
AR Transformers Inc.
Maddox Transformer
JST Power Transformers
Killen Group America

Bidders desiring to quote non-accepted transformer manufacturers must first contact the Director of Electric Systems for conditional approval by the Commission for **each** bid. **Conditional approval shall not constitute acceptance of the manufacturer by the Commission nor a commitment to award all or any part of any current or future bids to the bidder until accepted as an approved manufacturer and added to GUC's specifications as an acceptable manufacturer.** As deemed appropriate by the Commission, additional conditions or requirements may be extended as a condition of any purchases or awards.

SUBMIT BIDS ON ATTACHED PROPOSAL FORM(S)

[Balance of page left blank intentionally]

Vendor Name: _____

GREENVILLE UTILITIES COMMISSION

PROPOSAL FORM TRANSFORMERS

JUNE 4, 2026

The undersigned bidder hereby declares that it has carefully examined the enclosed detailed specifications for furnishing GUC with the below listed items. The undersigned bidder further agrees, if this proposal is accepted within sixty (60) days from the date of the opening, to furnish any or all of the items upon the quoted price.

Item No.	Est. Qty.	Description	Delivery Time	Unit Price	Ownership Cost/Unit	Total
----------	-----------	-------------	---------------	------------	---------------------	-------

1	2	STK# 205830 Transformer, 2,000 KVA Three-Phase Pad Mount	_____	\$_____	\$_____	\$_____
---	---	---	-------	---------	---------	---------

Avg. NL Losses in Watts: _____

Avg. LD Losses in Watts: _____

Manufacturer: _____

Place of Mfg: _____

HV Winding Material: _____

LV Winding
Material: _____

Core Material: _____

KT Core
Factor: _____

TOTAL FOR – ITEM I		\$ _____
TOTAL FOR ITEMS I	Totals	\$ _____

Method of Award: GUC, in its sole discretion, may award this bid as individual item(s) or as a total bid for item(s) I.

Award of transformer bids shall be primarily based upon the lowest estimated total ownership cost (TOC) to the Commission using the currently approved Electricities Transformer Formula (Refer to Section 1, Paragraph 9.0). If the total ownership cost difference between the apparent lowest cost unit and any other units is less than 3%, then the Commission has the option to evaluate these units on lowest initial cost and award on this basis, taking into account quoted delivery time. In addition to the estimated TOC, quoted delivery time and past performance of the bidder and/or manufacturer with respect to other bid awards shall be considered in evaluating and awarding bids.

Complete and Check All Math: It is the responsibility of the Bidder to extend bid prices and supply a total for all items.

[Balance of page left blank intentionally]

Letter of Compliance to E-Verify for Greenville Utilities Commission

1. I have submitted a bid for contract or desire to enter into a contract with the Greenville Utilities Commission;
2. As part of my duties and responsibilities pursuant to said bid and/or contract, I affirm that I am aware of and in compliance with the requirements of E-Verify, Article 2 of Chapter 64 of the North Carolina General Statutes, to include (mark which applies):

3. ____ After hiring an employee to work in the United States I verify the work authorization of said employee through E-Verify and retain the record of the verification of work authorization while the employee is employed and for one year thereafter; or
4. ____ I employ less than twenty-five (25) employees in the State of North Carolina.

5. As part of my duties and responsibilities pursuant to said bid and/or contract, I affirm that to the best of my knowledge and subcontractors employed as a part of this bid and/or contract, are in compliance with the requirements of E-Verify, Article 2 of Chapter 64 of the North Carolina General Statutes, to include (mark which applies):

6. ____ After hiring an employee to work in the United States the subcontractor verifies the work authorization of said employee through E-Verify and retains the record of the verification of work authorization while the employee is employed and for one year thereafter; or

7. ____ Employ less than twenty-five (25) employees in the State of North Carolina.

Specify subcontractor: _____

_____ (Company Name)

By: _____ (Typed Name)

_____ (Authorized Signatory)

_____ (Title)

_____ (Date)

WILDLIFE CONNECTOR CAPS

Molded Plastic Type



These caps are the ultimate answer for transformer protection against short circuit hazards caused by wildlife. All current carrying exposed parts are completely removed as short circuit hazards by these Protective Connector Caps.

These caps can be used to Wildlife Proof most modern H. V. Cover Bushings presently in use. Unscrew the original connector and put our Connector Cap in its place.

The Hood and Handwheel are of sturdy molded glass filled polyester. The molded plastic handwheel operates an eyebolt to securely lock the conductor in place. Available with eyebolt capacity of $\frac{7}{16}$ " (for No. 10 to 2/0) or $\frac{5}{8}$ " (for No. 6 to 4/0 copper).

Both the Hood and Handwheel are furnished in standard gray. Both types are equipped with "knockout" slot where lightning arrester leads are required. All threaded parts are removable and replaceable in the field.

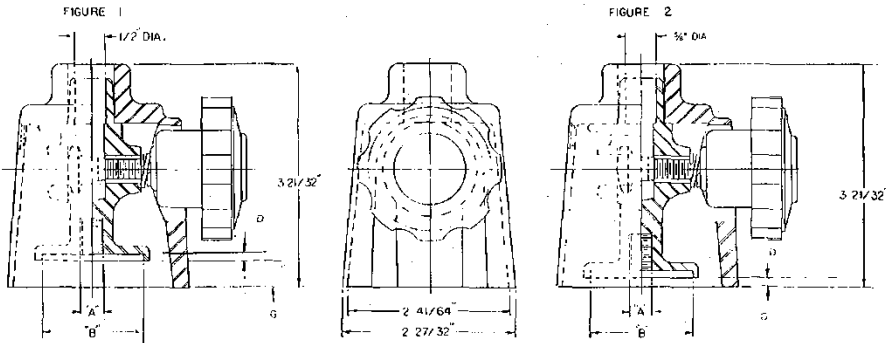

WILDLIFE-PROOF CONNECTOR CAP

PART No.	FIGURE	BUSHING TOP DIAMETER "B"	"A" THREAD	EYEBOLT SIZE	D	G
65001	1	1 $\frac{1}{8}$ "	$\frac{3}{8}$ "-16	$\frac{3}{16}$ " ID	$\frac{1}{8}$	1 $\frac{3}{32}$
65002	1	1 $\frac{1}{8}$ "	$\frac{1}{2}$ "-20	$\frac{3}{16}$ " ID	$\frac{1}{8}$	1 $\frac{3}{32}$
65003	1	1 $\frac{1}{8}$ "	$\frac{3}{8}$ "-24	$\frac{3}{16}$ " ID	$\frac{1}{8}$	1 $\frac{3}{32}$
65004	1	1 $\frac{1}{8}$ "	$\frac{3}{8}$ "-24	$\frac{3}{16}$ " ID	$\frac{1}{8}$	1 $\frac{3}{32}$
65010	1	1 $\frac{3}{8}$ "	$\frac{3}{8}$ "-16	$\frac{3}{16}$ " ID	$\frac{3}{16}$	1 $\frac{1}{32}$
65011	1	1 $\frac{3}{8}$ "	$\frac{1}{2}$ "-20	$\frac{3}{16}$ " ID	$\frac{3}{16}$	1 $\frac{1}{32}$
65012	1	1 $\frac{3}{8}$ "	$\frac{3}{8}$ "-24	$\frac{3}{16}$ " ID	$\frac{3}{16}$	1 $\frac{1}{32}$
65013	1	1 $\frac{3}{8}$ "	$\frac{3}{8}$ "-24	$\frac{3}{16}$ " ID	$\frac{3}{16}$	1 $\frac{1}{32}$
65014	1	1 $\frac{3}{8}$ "	$\frac{3}{8}$ "-18	$\frac{3}{16}$ " ID	$\frac{3}{32}$	1 $\frac{1}{32}$
65015	2	1 $\frac{3}{8}$ "	$\frac{3}{8}$ "-16	$\frac{3}{8}$ " ID	$\frac{3}{16}$	$\frac{5}{32}$
65016	2	1 $\frac{3}{8}$ "	$\frac{1}{2}$ "-20	$\frac{3}{8}$ " ID	$\frac{3}{16}$	$\frac{5}{32}$
65017	2	1 $\frac{3}{8}$ "	$\frac{3}{8}$ "-24	$\frac{3}{8}$ " ID	$\frac{3}{16}$	$\frac{5}{32}$
65018	2	1 $\frac{3}{8}$ "	$\frac{3}{8}$ "-24	$\frac{5}{8}$ " ID	$\frac{3}{16}$	$\frac{5}{32}$
65019	2	1 $\frac{3}{8}$ "	$\frac{1}{2}$ "-13	$\frac{5}{8}$ " ID	$\frac{3}{16}$	$\frac{5}{32}$

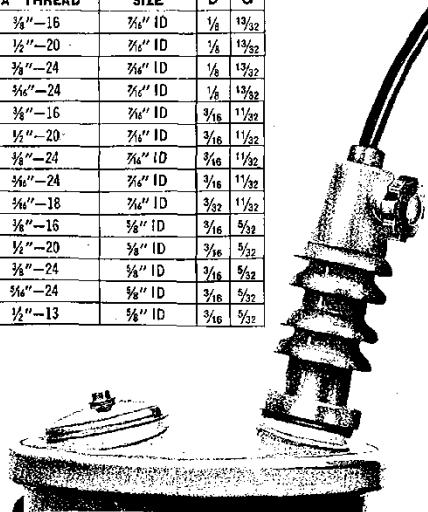
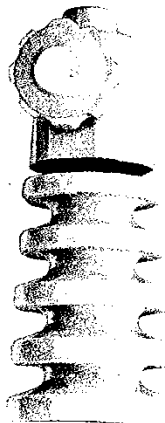

Porcelain Products Co., Carey, Ohio 43316

SECTION III

TERMS AND CONDITIONS FOR THE PURCHASE OF APPARATUS, SUPPLIES, MATERIALS, LABOR AND EQUIPMENT

These Terms and Conditions, made and entered into on this the ___ day of _____, by and between GREENVILLE UTILITIES COMMISSION OF THE CITY OF GREENVILLE, PITT COUNTY, NORTH CAROLINA, with one of its principal offices and places of business at 401 S. Greene Street, Post Office Box 1847, Greenville, Pitt County, North Carolina 27835-1847, hereinafter referred to as "GUC" and _____, a _____ organized and existing under and by virtue of the laws of the State of _____, with one of its principal offices and places of business at _____, hereinafter referred to as "PROVIDER";

1.0 TAXES

No taxes shall be included in any bid prices. GUC is exempt from Federal Excise Tax. GUC is not exempt from North Carolina state sales and use tax or, if applicable, Pitt County sales and use tax. Such taxes shall be shown as a separate item on the invoice.

2.0 INVOICES

It is understood and agreed that orders will be shipped at the established contract prices and quantities in effect on dates orders are placed. Invoicing at variance with this provision may subject the contract to cancellation. Applicable North Carolina sales tax shall be invoiced as a separate line item. All invoices must bear the GUC purchase order number. Mail all invoices to Greenville Utilities Commission, Finance Department, P. O. Box 1847, Greenville, NC 27835-1847.

3.0 PAYMENT TERMS

Payments for equipment, materials, or supplies will be made after the receipt and acceptance of the equipment, materials, supplies or services and after submission of a proper invoice. GUC's normal payment policy is thirty (30) days. GUC will not be responsible for any goods delivered without a purchase order having been issued. Payment will be made in U. S. currency only.

4.0 QUANTITIES

Quantities specified are only estimates of GUC's requirements. GUC reserves the right to purchase more or less than the stated quantities at prices indicated in the submitted Proposal Form based on our actual needs.

5.0 AFFIRMATIVE ACTION

The Provider will take affirmative action in complying with all Federal and State requirements concerning fair employment and employment of the handicapped, and concerning the treatment of all employees, without discrimination by reason of race, color, religion, sex, national origin, or physical handicap.

6.0 CONDITION AND PACKAGING

Unless otherwise indicated in the bid, it is understood and agreed that any item offered or shipped shall be new and in first class condition, that all containers shall be new and suitable for storage or shipment, and that prices include standard commercial packaging.

7.0 SAMPLES

Samples of items, if required, must be furnished free of expense to GUC, and if not destroyed, will, upon request, be returned at the Provider's expense. Request for the return of samples must be made at the bid opening, otherwise, the samples will become GUC's property. Each individual sample must be labeled with Provider's name.

8.0 SPECIFICATIONS

Any deviation from specifications must be clearly pointed out, otherwise, it will be considered that items offered are in strict compliance with specifications, and the Provider will be held responsible. Deviations must be explained in detail. **The Provider shall not construe this paragraph as inviting deviation or implying that any deviation will be acceptable.**

9.0 INFORMATION AND DESCRIPTIVE LITERATURE

Providers are to furnish all information requested. Further, as may be specified elsewhere, each Provider must submit with its proposal: cuts, sketches, descriptive literature, and/or complete specifications covering the products offered. Reference to literature submitted with a previous bid does not satisfy this provision. Bids which do not comply with these requirements will be subject to rejection.

10.0 AWARD OF CONTRACT

As directed by statute, qualified bids will be evaluated and acceptance made of the lowest responsible, responsive bid most advantageous to GUC as determined upon consideration of such factors as prices offered, the quality of the article(s) offered, the general reputation and performance capabilities of the Provider, substantial conformity with the specifications and other conditions set forth in the bid, the suitability of the article(s) for the intended use, the related services needed, the date(s) of delivery and performance, and such other factors deemed by GUC to be pertinent or peculiar to the purchase in question.

Acceptance of the order includes acceptance of all terms, conditions, prices, delivery instructions, and specifications as shown on this set of Terms and Conditions and in this order or attached to and made a part of this order.

The conditions of this order cannot be modified except by written amendment in the form of "Amended Purchase Order," which has been approved by GUC's Procurement Manager.

In the event of a Provider's failure to deliver or perform as specified, GUC reserves the right to cancel the order or any part thereof, without prejudice to GUC's other rights. The Provider agrees that GUC may return part of or all of any shipment at Provider's expense. GUC may charge the Provider with all reasonable expenses resulting from such failure to deliver or perform.

11.0 MEDIATION/BINDING ARBITRATION

In the event of any dispute between the Parties, the Parties agree to submit any dispute to non-binding mediation before a mutually agreeable Mediator prior to initiating litigation. If the Parties are unable to agree upon a Mediator within thirty (30) days after demand therefore, either Party may petition a Court of competent jurisdiction for the designation of a qualified Mediator for these purposes. Each Party shall bear its own costs and expenses of participating in the mediation (including, without limitation, reasonable attorneys' fees), and each Party shall bear one-half (1/2) of the costs and expenses of the Mediator. Unless otherwise agreed, the Parties will hold the mediation in Greenville, North Carolina. The matters discussed or revealed in the mediation session shall not be disclosed in any subsequent litigation.

In the event the matter is not resolved in mediation, either Party may request arbitration. The parties shall jointly select an Arbitrator, and shall be bound by the decision of the Arbitrator with respect to any dispute between the parties with respect to this Agreement. If the parties are unable to mutually agree upon an Arbitrator, the Parties shall each select an Arbitrator, and the two Arbitrators so selected shall select a third Arbitrator, and the decision of the majority of the Arbitrators shall be conclusive and binding upon the Parties. The Parties at all times agree to equally split the costs of any Arbitrator(s) selected in an effort to resolve the dispute between the Parties. Any party desiring to resolve a dispute under the terms of this Agreement shall notify the other Party in writing, and the Parties shall seek to agree upon a mutually agreed-upon Arbitrator within a period of ten (10) days from the date of such written demand. If the Parties are unable to agree within such ten (10) day period, the Parties shall each select an Arbitrator, and the two (2) Arbitrators so selected shall select a third Arbitrator within fifteen (15) days from the date of the written demand for arbitration, and a decision shall be rendered by the Arbitrator(s) so selected within five (5) days after such Arbitrator(s) is selected.

12.0 GOVERNMENT RESTRICTIONS

In the event any Governmental restrictions may be imposed which would necessitate alteration of the material, quality, workmanship, or performance of the items offered on this bid prior to their delivery, it shall be the responsibility of the successful Provider to notify the GUC Procurement Manager, at once, indicating in its letter the specific regulation which required such alterations. GUC reserves the right to accept any such alterations, including any price adjustments occasioned thereby, or, in the sole discretion of GUC, to cancel the contract.

13.0 INSURANCE

13.1 Coverage – During the term of the contract, the Provider at its sole cost and expense shall provide commercial insurance of such type and with the following coverage and limits:

13.1.1 Workers' Compensation – The Provider shall provide and maintain Workers' Compensation Insurance, as required by the laws of North Carolina, as well as employer's liability coverage with minimum limits of \$1,000,000 each accident, covering all Provider's employees who are engaged in any work under the contract. If any work is sublet, the Provider shall require the subcontractor to provide the same coverage for any of its employees engaged in any work under the contract.

13.1.2 General Liability – Commercial Liability Coverage written on an “occurrence” basis in the minimum amount of \$1,000,000 per occurrence.

13.1.3 Automobile – Automobile Liability Insurance, to include coverage for all owned, hired, and non-owned vehicles used in connection with the contract with a minimum combined single limit of \$1,000,000 per accident.

13.1.4 Cyber –The Vendor shall maintain Cyber Liability Insurance with limits of \$3,000,000 per occurrence, providing protection against liability for: (1) privacy breaches (including liability arising from the loss or disclosure of confidential information no matter how it occurs); (2) system breach; (3) denial or loss of service; (4) introduction, implantation, or spread of malicious software code; and (5) unauthorized access to or use of computer systems. Cyber Liability Insurance shall not include any exclusion or restriction for unencrypted portable devices or other media. Vendor shall provide evidence of continuation or renewal for a period of two (2) years following termination of the Agreement.

13.2 Requirements - Providing and maintaining adequate insurance coverage is a material obligation of the Provider. All such insurance shall meet all laws of the State of North Carolina. Such insurance coverage shall be obtained from companies that are authorized to provide such coverage and that are authorized to do business in North Carolina by the Commissioner of Insurance. The Provider shall at all times comply with the terms of such insurance policies and all requirements of the insurer under any of such insurance policies, except as they may conflict with existing North Carolina laws or this contract. The limits of coverage under each insurance policy maintained by the Provider shall not be interpreted as limiting the Provider’s liability and obligations under the contract. It is agreed that the coverage as stated shall not be canceled or changed until thirty (30) days after written notice of such termination or alteration has been sent by registered mail to GUC’s Procurement Manager.

14.0 PATENTS AND COPYRIGHTS

The Provider shall hold and save GUC, its officers, agents, and employees, harmless from liability of any kind, including costs and expenses, including reasonable attorney fees, on account of any copyrighted articles or any patented or unpatented invention, device or appliance manufactured or used in the performance of this contract.

15.0 PATENT AND COPYRIGHT INDEMNITY

The Provider will defend or settle, at its own expense, any action brought against GUC to the extent that it is based on a claim that the product(s) provided pursuant to this agreement infringe any U.S. copyright or patent; and will pay those costs, damages, and attorney fees finally awarded against GUC in any such action attributable to any such claim, but such defense, settlements, and payments are conditioned on the following: (1) that Provider shall be notified promptly in writing by GUC of any such claim; (2) that Provider shall have sole control of the defense of any action on such claim and of all negotiations for its settlement or compromise; (3) that GUC shall cooperate with Provider in a reasonable way to facilitate the settlement of defense of such claim; (4) that such claim does not arise from GUC modifications not authorized

by the Provider or from the use of combination of products provided by the Provider with products provided by GUC or by others; and (5) should such product(s) become, or in the Provider's opinion likely to become, the subject of such claim of infringement, then GUC shall permit Provider, at Provider's option and expense, either to procure for GUC the right to continue using the product(s), or replace or modify the same so that it becomes non-infringing and performs in a substantially similar manner to the original product.

16.0 EXCEPTIONS

All proposals are subject to the terms and conditions outlined herein. All responses will be controlled by such terms and conditions and the submission of other terms and conditions, price catalogs, and other documents as part of a Provider's response will be waived and have no effect on this Request for Proposal or any other contract that may be awarded resulting from this solicitation. The submission of any other terms and conditions by a Provider may be grounds for rejection of the Provider's proposal. The Provider specifically agrees to the terms and conditions set forth in this set of Terms and Conditions by affixing its name on the signatory page contained herein.

17.0 CONFIDENTIAL INFORMATION

Except as provided by statute and rule of law, GUC will keep trade secrets which the Provider does not wish disclosed confidential. Each page shall be identified in boldface at the top and bottom as "CONFIDENTIAL" by the Provider. Cost information shall not be deemed confidential. The determination of whether a matter is confidential will be determined by North Carolina law.

18.0 ASSIGNMENT

No assignment of the Provider's obligations or the Provider's right to receive payment hereunder shall be permitted without the express written consent of GUC, provided however, upon written request approved by the GUC Procurement Manager, solely as a convenience to the Provider, GUC may:

- Forward the Provider's payment check directly to any person or entity designated by the Provider, and
- Include any person or entity designated by Provider as a joint payee on the Provider's payment check.
- In no event shall such approval and action obligate GUC to anyone other than the Provider, and the Provider shall remain responsible for fulfillment of all contract obligations.

19.0 ACCESS TO PERSON AND RECORDS

GUC shall have reasonable access to persons and records of Provider as a result of all contracts entered into by GUC.

20.0 INSPECTION AT BIDDER'S SITE

GUC reserves the right to inspect, at a reasonable time, the item, plant, or other facilities of a prospective Provider prior to contract award and during the contract term as necessary for GUC's determination that such item, plant, or other facilities conform with the specifications/requirements and are adequate and suitable for the proper and effective performance of the contract. Provider may limit GUC's access to restricted areas.

21.0 AVAILABILITY OF FUNDS

Any and all payments of compensation of this specific transaction and any continuation or any renewal or extension are dependent upon and subject to the allocation of GUC funds for the purpose set forth in this Agreement.

22.0 GOVERNING LAWS

All contracts, transactions, agreements, etc., are made under and shall be governed by and construed in accordance with the laws of the State of North Carolina.

23.0 ADMINISTRATIVE CODE

Bids, proposals, and awards are subject to applicable provisions of the North Carolina Administrative Code and General Statutes and Laws of the State of North Carolina.

24.0 EXECUTION

In the discretion of GUC, failure of a duly authorized official of Provider to sign the Signatory Page may render the bid invalid.

25.0 CLARIFICATIONS/INTERPRETATIONS

Any and all questions regarding these Terms and Conditions must be addressed to the GUC Procurement Manager. Do not contact the user directly. **These Terms and Conditions are a complete statement of the parties' agreement and may only be modified in writing signed by Provider and the GUC Procurement Manager.**

26.0 SITUS

The place of all contracts, transactions, agreements, their situs and forum, shall be North Carolina, where all matters, whether in contract or tort, relating to the validity, construction, interpretation, and enforcement shall be determined.

27.0 TERMINATION OF AGREEMENT

GUC or Provider may terminate this Agreement for just cause at any time. Provider will be paid for all time and expenses incurred as of the termination date. Termination for just cause by either party shall be by certified letter and shall be effective thirty (30) days after signed and acknowledged receipt of said letter. Just cause shall be based on reasonable grounds, and there must be a fair and honest cause or reason for such action. The causes for termination,

include, but are not limited to: (1) Provider's persistent failure to perform in accordance with the Terms and Conditions, (2) Provider's disregard of laws and regulations related to this transaction, and/or (3) Provider's substantial violation of the provisions of the Terms and Conditions.

28.0 DELIVERY

Shipments will be made only upon releases from a purchase order issued by GUC in accordance with GUC's current needs.

Time is of the essence with respect to all deliveries under this Agreement.

Delivery of all equipment, materials, or supplies shall be made Free on Board (FOB) GUC Warehouse, 701 Utility Way, Greenville, North Carolina 27834, unless otherwise specified. The agreed price for such equipment, materials, or supplies shall include all costs of delivery and ownership, and risks of loss shall not be transferred from Provider to GUC until express written acceptance of delivery and inspection by GUC. Delivery hours are between 8:00 AM and 4:30 PM Monday-Friday only. **GUC's purchase order number is to be shown on the packing slip or any related documents.** GUC reserves the right to refuse or return any delivery with no purchase order number or which is damaged. GUC will not be charged a restocking fee for any delivery which is refused or returned.

29.0 INDEMNITY PROVISION

Provider agrees to indemnify and save GREENVILLE UTILITIES COMMISSION of the City of Greenville, Pitt County, North Carolina, and the City of Greenville, North Carolina, its co-owners, joint venturers, agents, employees, and insurance carriers harmless from any and all losses, claims, actions, costs, expenses including reasonable attorney fees, judgments, subrogations, or other damages resulting from injury to any person (including injury resulting in death), or damage (including loss or destruction) to property of whatsoever nature of any person arising out of or incident to the performance of the terms of this Contract by Provider, including, but not limited to, Provider's employees, agents, subcontractors, and others designated by Provider to perform work or services in, about, or attendant to, the work and services under the terms of this Contract. Provider shall not be held responsible for any losses, expenses, claims, subrogations, actions, costs, judgments, or other damages, directly, solely, and proximately caused by the negligence of Greenville Utilities Commission of the City of Greenville, Pitt County, North Carolina. Insurance covering this indemnity agreement by the Provider in favor of Greenville Utilities Commission of the City of Greenville, Pitt County, North Carolina, and the City of Greenville, North Carolina, shall be provided by Provider.

30.0 FORCE MAJEURE

Neither party shall be considered in default in the performance of its obligations hereunder to the extent that the performance of any such obligation is prevented or delayed by any cause, existing or future, which is beyond the reasonable control of such party. In any such event of force majeure, the parties shall advise each other of such event, and the parties shall negotiate an equitable adjustment to their respective obligations under this Agreement.

31.0 WARRANTY(IES)

The Provider hereby includes all warranties, whether expressed or implied, including, but not limited to, the Implied Warranty of Merchantability and the Implied Warranty of Fitness for a Particular Purpose.

32.0 INTEGRATED CONTRACT

These Terms and Conditions, Instructions to Bidders, Specifications, and the selected Provider's bid represents the entire contract between the Parties. No verbal or other written agreement(s) shall be held to vary the provisions of this Agreement.

33.0 CONTRACT PROVISIONS

Each of the provisions of these Terms and Conditions shall apply to the full extent permitted by law, and the invalidity in whole or in part of any provision shall not affect the remainder of such provision or any other provisions.

34.0 E-VERIFY

E-Verify - I understand that E-Verify is the federal E-Verify program operated by the United States Department of Homeland Security and other federal agencies, or any successor or equivalent program used to verify the work authorization of newly hired employees pursuant to federal law in accordance with NCGS §64-25 et seq. I am aware of and in compliance with the requirements of E-Verify and Article 2 of Chapter 64 of the North Carolina General Statutes. To the best of my knowledge, any subcontractors employed by me as a part of this contract are in compliance with the requirements of E-Verify and Article 2 of Chapter 64 of the North Carolina General Statutes.

35.0 IRAN DIVESTMENT ACT CERTIFICATION

By acceptance of this purchase order, Vendor/Contractor certifies that, as of the date of the purchase order or contract, it is not on the Final Divestment List as created by the State Treasurer pursuant to N.C.G.S. § 143-6A-4. In compliance with the requirements of the Iran Divestment Act and N.C.G.S. § 143C-6A-5(b), Vendor/Contractor shall not utilize in the performance of the contract any subcontractor that is identified on the Final Divestment List.

36.0 UNIFORM GUIDANCE

Contracts funded with federal grant or loan funds must be procured in a manner that conforms with all applicable federal laws, policies, and standards, including those under the Uniform Guidance (2 C.F.R. Part 200).

37.0 SAFETY STATEMENTS

Safety Culture Commitment Statement:

At Greenville Utilities, we are committed to a culture of safety that prioritizes the well-being of our employees, contractors, and the communities we serve.

We believe that everyone deserves to work in a safe environment, and we are dedicated to fostering a culture where **safety is a core value, not just a priority.**

Here's what that means to us:

- **Employee and Contractor Safety:** We are committed to providing a safe work environment for all employees and contractors. We will invest in safety training, resources, and equipment to prevent accidents and injuries.
- **Open Communication:** We encourage open and honest communication about safety concerns. We believe everyone has a right and responsibility to speak up about unsafe work practices and potential hazards.

- **Continuous Improvement:** We are committed to continuous improvement in safety performance. We will learn from incidents and near misses, and we will actively seek ways to improve our safety processes and procedures.
- **Accountability:** We hold ourselves and our contractors accountable for safe work practices. This includes providing clear safety expectations, enforcing safety rules, and recognizing safe behavior.
- **Collaboration:** We believe in working collaboratively with employees, contractors, and regulatory agencies to achieve the highest level of safety.

Our commitment to safety extends beyond our employees. We work closely with our contractors to ensure they share our safety values. We expect them to implement robust safety programs, train their workers thoroughly, and adhere to all safety regulations.

We are confident that by working together, we can create a culture of safety where everyone goes home safe and healthy every day.

This commitment statement is a public declaration of our unwavering dedication to safety. We will continue to strive for zero incidents while promoting a positive safety culture that prioritizes the well-being of everyone involved in our utility operations.

Safety Management System Commitment Statement:

At Greenville Utilities, we are unwavering in our commitment to delivering safe and reliable utility service through a robust Safety Management System (SMS). This system forms the foundation of our safety culture, ensuring the well-being of our employees, contractors, and the communities we serve.

Our SMS commitment emphasizes:

- **Zero Incidents:** We believe all incidents are preventable. We strive for zero incidents by proactively managing risks and continuously improving our safety practices.
- **Empowered Workforce:** We foster a culture where safety is everyone's responsibility. This includes providing comprehensive safety training for both employees and contractors, empowering them to identify and report hazards.
- **Data-Driven Decisions:** We utilize data from inspections, incident investigations, and performance metrics to make informed decisions for risk mitigation and continuous improvement of our SMS.
- **Leadership Engagement:** Our leadership team actively demonstrates a commitment to safety by participating in safety reviews, audits, and promoting safety as a core value.
- **Contractor Collaboration:** We extend our safety commitment to our contractors. We require contractors working on our system to adhere to SMS principles, participate in safety briefings, and maintain strong safety programs within their own organizations.
- **Transparent Communication:** We believe in open communication about safety. We encourage employees and contractors to report concerns without fear of reprisal. We also maintain transparent communication with stakeholders about SMS performance.

This SMS commitment is a continuous journey, not a destination. We are dedicated to regularly reviewing and updating our system to reflect best practices and emerging technologies. Through continuous improvement and a commitment to a positive safety culture, we aim to remain an industry leader in safe and reliable utility service.

38.0 INFORMATION TECHNOLOGY

All Contracts are subject to Greenville Utilities Commission Information Technology Contract Provisions. These may be viewed at www.guc.com/doing-business-us.

39.0 NOTICES

Notices to the Parties should be sent to the names and addresses specified below:

Cleve Haddock, Lifetime CLGPO
Procurement Manager
Greenville Utilities Commission
P.O. Box 1847
Greenville, NC 27835-1847

Vendor Specified on Page 1 of Section III when awarded.

GREENVILLE UTILITIES COMMISSION

By: _____
Anthony C. Cannon

Title: General Manager/CEO
(Authorized Signatory)

Date: _____

Attest: _____

Name (Print): Amy Wade

Title: Executive Secretary

Date: _____

(OFFICIAL SEAL)

COMPANY NAME:

By: _____

Name (Print): _____

Title: _____
(Authorized Signatory)

Date: _____

Attest: _____

Name (Print): _____

Title: Corporate Secretary

Date: _____

(CORP. SEAL)

APPROVED AS TO FORM AND LEGAL CONTENT:

By: _____
Phillip R. Dixon

Title: General Counsel

Date: _____