

# **NORTHSIDE COMMERCIAL CENTER SANITARY SEWER EXTENSION**

**GREENVILLE, NORTH CAROLINA  
FEBRUARY 2021**

**Drawing No. D-1244**



Firm License No. P-1199



# NORTHSIDE COMMERCIAL CENTER SANITARY SEWER EXTENSION

GREENVILLE, NORTH CAROLINA  
FEBRUARY 2021  
Drawing No. D-1244



 2/12/2021  
Bryan C. Fagundus, P.E.

**ARK**  
**CONSULTING GROUP, PLLC**  
ENGINEERS & PLANNERS

Firm License No. P-1199



**TABLE OF CONTENTS**

|   | <u>Page No.</u> |
|---|-----------------|
| Advertisement for Bids - 00100                                      | AB-1 - 2        |
| Instructions to Bidders - 00200                                     | IB-1 - 15       |
| Bid - 00410   | B-1 - 9         |
| Bid Bond - 00430  | BB-1 - 3        |
| Special Instructions to Bidders – GUC M/WBE Program                 | MB-1 - 3        |
| Identification of Minority Business Participation                   | MB-4            |
| Affidavit A - Listing of Good Faith Efforts                         | MB-5            |
| Affidavit B - Intent to Perform Contract with Own Workforce         | MB-6            |
| Affidavit C - Portion of the Work to be Performed by Minority Firms | MB-7            |
| Affidavit D - Good Faith Efforts                                    | MB-8 - 9        |
| Letter of Intent – M/WBE Subcontractor Performance                  | MB-10           |
| Request to Change M/WBE Participation                               | MB-11 – 12      |
| Proof of Payment Certification                                      | MB-13           |
| E-Verify Letter of Compliance                                       | E-1             |
| Notice of Award - 00510   | NA-1            |
| Agreement - 00520   | A-1 - 8         |
| Notice to Proceed - 00550   | NP-1            |
| Performance Bond  | PB-1 - 3        |
| Payment Bond  | PB-1 - 3        |
| Certificate of Liability Insurance - 00616                          | CI-1            |
| Certificate of Finance Officer                                      | CFO-1           |
| Certificate of Owner’s Attorney                                     | COA-1           |
| Application for Payment - 00620                                     | AP-1 - 4        |
| Certificate of Final Completion                                     | CFC-1 - 2       |
| Waiver of Lien - 00626  | WL-1 - 2        |
| General Conditions - 00700  | GC-1 - 65       |
| Supplementary Conditions - 00800                                    | SC-1 - 7        |
| Change Order - 00941  | CO-1 - 2        |
| Field Order - 00942   | FO-1 – 1        |

**DETAIL SPECIFICATIONS****DIVISION 1 - GENERAL REQUIREMENTS**

|                                      |              |
|--------------------------------------|--------------|
| Section 01010 - Project Requirements | 01010-1 - 12 |
| Section 01150 – Payment              | 01150-1 - 2  |
| Section 01300 - Submittals           | 01300-1 - 6  |
| Section 01400 - Quality Control      | 01400-1 - 2  |
| Section 01500 - Temporary Facilities | 01500-1 - 5  |
| Section 01700 - Project Closeout     | 01700-1 - 2  |

DIVISION 2 - SITE WORK

|   |              |
|---|--------------|
| Section 02110 - Site Clearing                         | 02110-1 - 3  |
| Section 02220 - Trenching, Backfilling and Compaction | 02220-1 - 11 |
| Section 02513 - Bituminous Concrete Paving            | 02513-1 - 4  |
| Section 02737 - Gravity Sanitary Sewer System         | 02737-1 - 13 |
| Section 02910 - Erosion and Pollution Control         | 02910-1 - 6  |
| Section 02920 - Fertilizing, Seeding and Mulching     | 02920-1 - 6  |

DIVISION 3 - CONCRETE WORK

|                          |             |
|--------------------------|-------------|
| Section 03305 - Concrete | 03305-1 - 5 |
|--------------------------|-------------|

ADVERTISEMENT FOR BIDS  
GREENVILLE UTILITIES COMMISSION  
NORTHSIDE COMMERCIAL CENTER – SANITARY SEWER EXTENSION  
GREENVILLE, NORTH CAROLINA

Informal bids will be received in the Office of the Procurement Manager, Greenville Utilities Commission, 401 S. Greene Street, Greenville, North Carolina 27834 until 4:00 pm (EDST) on March 4, 2021, for constructing the following facilities:

GREENVILLE UTILITIES COMMISSION  
NORTHSIDE COMMERCIAL CENTER – SANITARY SEWER IMPROVEMENTS

Informal Bids must be submitted on the complete project. Informal Bids must be enclosed in a sealed envelope, addressed to **Procurement Manager, Greenville Utilities Commission, 401 S. Greene Street, Greenville, North Carolina 27834** and the outside of the envelope must be marked **“Bid for Northside Commercial Center – Sanitary Sewer Improvements”**. All bids must be made on blank forms provided and included in the bound document. The name, address, and license number with limitation and classification of the Bidder must be plainly marked thereon.

Each bid must be accompanied by cash, cashier’s check, or certified check drawn on a bank or trust company authorized to do business in North Carolina and insured with the Federal Deposit Insurance Corporation or the Savings Association Insurance Fund, payable to **GREENVILLE UTILITIES COMMISSION** in an amount at least equal to five percent (5%) of the total amount of the bid, as a guarantee that a contract will be entered into. In lieu of a certified check, the Bidder may submit a bid bond in the form prescribed in G.S. 143 129 as amended by Chapter 1104 of the Public Laws of 1951.

Contractors are notified that the North Carolina G.S. 87 relating to licensing of contractors together with applicable provisions of the North Carolina Administrative Code and General Statutes and Laws of the State of North Carolina will be observed in receiving bids and awarding contracts.

The major items of work include:

Approximately 1,150 LF of 8” gravity sanitary sewer main,  
Approximately 5 EA sanitary sewer manholes,  
Approximately 6 EA sanitary sewer services

Plans and specifications are on file and may be examined at the Office of the Procurement Manager, Greenville Utilities Commission, 401 S. Greene Street, Greenville, North Carolina 27834 during regular office hours, which are 8:30AM – 5:00PM Monday through Friday.

Greenville Utilities Commission  
Office of the Procurement Manager  
Mr. Cleve Haddock, CLGPO, Procurement Manager  
(252) 551-1533  
haddocgc@guc.com

With request for Bidding Documents supply the following information: Company name, contact person, street address, phone and fax numbers, and email address for Bidding office; N.C. contractor's license with limitation and classification; indicate if the firm will be a Bidder, Supplier or Subcontractor.

Contracts shall be awarded to the lowest responsible, responsive bidder, taking into consideration quality, performance and the time specified in the bids for the performance of the contract. The right is reserved to reject any or all bids, to waive informalities, and to award contract or contracts which, in the opinion of the Owner, appear to be in its best interest.

Signed: Mr. Cleve Haddock, CLGPO, Procurement Manager  
Greenville Utilities Commission  
Office of the Procurement Manager  
401 S. Greene Street  
Greenville, NC 27834



**INSTRUCTIONS TO BIDDERS****TABLE OF CONTENTS**

|  | <b>Page</b> |
|--|-------------|
| Article 1 – Defined Terms  | 2           |
| Article 2 – Copies of Bidding Documents                                    | 2           |
| Article 3 – Qualifications of Bidders                                      | 3           |
| Article 4 – Examination of Bidding Documents, Other Related Data, and Site | 5           |
| Article 5 – Pre-Bid Conference   | 8           |
| Article 6 – Site and Other Areas   | 8           |
| Article 7 – Interpretations and Addenda                                    | 8           |
| Article 8 – Bid Security   | 8           |
| Article 9 – Contract Times   | 9           |
| Article 10 – Liquidated Damages  | 9           |
| Article 11 – Substitute and “Or-Equal” Items                               | 9           |
| Article 12 – Subcontractors, Suppliers and Others                          | 9           |
| Article 13 – Preparation of Bid  | 10          |
| Article 14 – Basis of Bid; Comparison of Bids                              | 11          |
| Article 15 – Submittal of Bid  | 12          |
| Article 16 – Modification and Withdrawal of Bid                            | 12          |
| Article 17 – Opening of Bids   | 12          |
| Article 18 – Bids to Remain Subject to Acceptance                          | 13          |
| Article 19 – Evaluation of Bids and Award of Contract                      | 13          |
| Article 20 – Contract Security and Insurance                               | 14          |
| Article 21 – Signing of Agreement  | 14          |
| Article 23 – Retainage   | 14          |

**ARTICLE 1 – DEFINED TERMS**

- 1.01 Terms used in these Instructions to Bidders have the meanings indicated in the General Conditions and Supplementary Conditions. Additional terms used in these Instructions to Bidders have the meanings indicated below:
- A. *Issuing Office* – The office from which the Bidding Documents are to be issued and where the bidding procedures are to be administered.
  - B. *Bid Schedule* – The Bid Schedule includes the Bidder’s prices and is part of Article 5 – Basis of Bid in the Bid Form.
  - C. *Successful BIDDER* – The lowest Responsible and Responsive BIDDER to whom OWNER (on the basis of OWNER’s evaluation is hereinafter provided) makes an award.
  - D. *Responsible BIDDER* – The entity who possesses the skill, ability and integrity necessary to faithfully perform the work called for by this contract, based upon a determination of competent workmanship, financial soundness, and other requirements outlined in these Bidding Documents.
  - E. *Responsive BIDDER* – The entity who accurately and completely delivers to the OWNER the required documentation and certifications outlined in these Bidding Documents.

**ARTICLE 2 – COPIES OF BIDDING DOCUMENTS**

- 2.01 Complete sets of the Bidding Documents may be obtained from the Issuing Office.
- 2.02 Complete sets of Bidding Documents shall be used in preparing Bids; neither Owner nor Engineer assumes any responsibility for errors or misinterpretations resulting from the use of incomplete sets of Bidding Documents.
- 2.03 Owner and Engineer, in making copies of Bidding Documents available on the above terms, do so only for the purpose of obtaining Bids for the Work and do not authorize or confer a license for any other use.

**ARTICLE 3 – QUALIFICATIONS OF BIDDERS**

3.01 To demonstrate Bidder's qualifications to perform the Work, within five days of Owner's request, Bidder shall submit written evidence such as financial data, previous experience, present commitments, and such other data as may be called for below.

- A. Official name of Bidder and length of time the organization has been in business under present name.**
- B. Address and phone numbers of company office that will manage the Project if different than that provided in the Bid.**
- C. Officers of the company. Name and resume of designated project manager and field superintendent. Number of regular employees of the organization.**
- D. Financial statements of the Bidder's company for the last three years including assets, liabilities, and other information requested by Owner to establish the Bidder's financial capability to complete the Project. The Bidder must also provide the names, addresses, and telephone numbers for at least two (2) major equipment suppliers, two (2) major material suppliers, and two (2) major subcontractors that the Owner may contact as financial references of the Bidder.**

**Record of failure to honor contractual commitments, consistent non-payment or payment not completed in a timely manner, and/or unfavorable references will be grounds for the Owner to disqualify the Bidder.**

- E. Name and home office address of the Surety proposed and the name and address of the responsible local claim agent.**
- F. Past experience on similar type and size projects within the past five (5) years, in the state for which this Project is to be constructed. Information shall include the list of similar projects, contact names and phone numbers of owners and engineers familiar with the listed projects, scheduled contract time and actual completion time, original and final contract price (include brief explanation of cost overruns and change orders), and subcontractors used on the projects.**

**Evidence of the lack of experience on similar type and size projects, consistently unfavorable interviews with owners and engineers for the projects, a consistent record of not completing the work on schedule, a record of substantial claims for change orders (all evaluations based upon interviews with the listed contact names), will be grounds for the Owner to disqualify the Bidder.**

- G. A list of all projects the Bidder will have under construction and/or commitment to at the time of the anticipated Notice to Proceed (assume 60 days from the Bid**

- date). This list shall include a complete description of each project including the type, size, structures, major equipment items, and contract amount. This list shall identify the office(s) from which these projects are being coordinated, managed, and staffed. The list shall also identify the number of personnel staffed for each project, along with the total number of personnel for the Bidder's corporation. Evidence that the Bidder is or will be "over-extended" during the Contract Time for this Project will be considered grounds for the Owner to disqualify the Bidder.
- H. A list of all subcontractors and suppliers expected to be utilized on this Project. The list shall include past project experience of the subcontractors and suppliers for similar type and size projects. Include contact names and telephone numbers of the subcontractors and suppliers listed for the Project.

A record of poor financial history with the listed subcontractors and suppliers (as outlined in Item "D" above), failure of the Bidder to provide the proper Contract Documents to the subcontractors and/or suppliers for their bidding purposes, and/or lack of experience on similar type and size projects will be considered grounds for the Owner to disqualify the Bidder. (Electrical subcontractors shall meet Subcontractor Qualifications outlined in Specification Section 16050 – Basic Electrical Materials and Methods)

- I. Statement that bidder is capable of completing the project within the stated time.
- J. The Bidder shall list any and all construction related claims or legal actions by the Contractor against Owners or Engineers in the last five years. Provide a list of any and all construction related claims or legal actions by the Owners, Engineers, or Subcontractors in the last five years.

Evidence of a pattern of claims and/or legal action either by the Bidder or against the Bidder will be considered grounds for the Owner to disqualify the Bidder.

- K. The above listed items shall be accompanied by the Contractor's Qualification Statement – 00420, CQS-1, located after the Bid Form. The Statement must be dated, executed, and notarized to be considered as complete.

Failure to include the Contractor's Qualification Statement – 00420, CQS-1, will be considered as grounds for the Owner to disqualify the Bidder.

- 3.02 Bidder is advised to carefully review those portions of the Bid Form requiring Bidder's representations and certifications.

**Bidders are notified that Chapter 87, Article(s) 1, 2, & 4 of the General Statutes of North Carolina, will be observed in receiving and awarding contracts. Bidders for this Project must be licensed in the following classifications and limitations:**

1. **License Classification**
  - a. **UNCLASSIFIED**
  - b. **PUBLIC UTILITIES CONTRACTOR**
  - c. **PU (Water and Sewer Lines)**
  
2. **Limitations:**
  - a. **"Limited": Up to \$500,000**
  - b. **"Intermediate": Up to \$1,000,000**
  - c. **"Unlimited": No limit on contract value**

#### **ARTICLE 4 – EXAMINATION OF BIDDING DOCUMENTS, OTHER RELATED DATA, AND SITE**

##### 4.01 *Subsurface and Physical Conditions*

- A. The Supplementary Conditions identify:
  1. Those reports known to Owner of explorations and tests of subsurface conditions at or contiguous to the Site.
  2. Those drawings known to Owner of physical conditions relating to existing surface or subsurface structures at the Site (except Underground Facilities).
  
- B. Copies of reports and drawings referenced in Paragraph 4.01.A will be made available by Owner to any Bidder on request. Those reports and drawings are not part of the Contract Documents, but the “technical data” contained therein upon which Bidder is entitled to rely as provided in Paragraph 4.02 of the General Conditions has been identified and established in Paragraph 4.02 of the Supplementary Conditions. Bidder is responsible for any interpretation or conclusion Bidder draws from any “technical data” or any other data, interpretations, opinions, or information contained in such reports or shown or indicated in such drawings. **The Bidder will be responsible for the cost associated with making the copies available.**

##### 4.02 *Underground Facilities*

- A. Information and data shown or indicated in the Bidding Documents with respect to existing Underground Facilities at or contiguous to the Site is based upon information and data furnished to Owner and Engineer by owners of such Underground Facilities, including Owner, or others.

#### 4.03 *Hazardous Environmental Condition*

- A. The Supplementary Conditions identify any reports and drawings known to Owner relating to a Hazardous Environmental Condition identified at the Site.
- B. Copies of reports and drawings referenced in Paragraph 4.03.A will be made available by Owner to any Bidder on request. Those reports and drawings are not part of the Contract Documents, but the “technical data” contained therein upon which Bidder is entitled to rely as provided in Paragraph 4.06 of the General Conditions has been identified and established in Paragraph 4.06 of the Supplementary Conditions. Bidder is responsible for any interpretation or conclusion Bidder draws from any “technical data” or any other data, interpretations, opinions, or information contained in such reports or shown or indicated in such drawings.  
**The Bidder will be responsible for the cost associated with making the copies available.**

4.04 Provisions concerning responsibilities for the adequacy of data furnished to prospective Bidders with respect to subsurface conditions, other physical conditions, and Underground Facilities, and possible changes in the Bidding Documents due to differing or unanticipated subsurface or physical conditions appear in Paragraphs 4.02, 4.03, and 4.04 of the General Conditions. Provisions concerning responsibilities for the adequacy of data furnished to prospective Bidders with respect to a Hazardous Environmental Condition at the Site, if any, and possible changes in the Contract Documents due to any Hazardous Environmental Condition uncovered or revealed at the Site which was not shown or indicated in the Drawings or Specifications or identified in the Contract Documents to be within the scope of the Work, appear in Paragraph 4.06 of the General Conditions.

4.05 On request, Owner will provide Bidder access to the Site to conduct such examinations, investigations, explorations, tests, and studies as Bidder deems necessary for submission of a Bid. Bidder shall fill all holes and clean up and restore the Site to its former condition upon completion of such explorations, investigations, tests, and studies. Bidder shall comply with all applicable Laws and Regulations relative to excavation and utility locates.

4.06 A. Reference is made to Article 7 of the Supplementary Conditions for the identification of the general nature of other work that is to be performed at the Site by Owner or others (such as utilities and other prime contractors) that relates to the Work contemplated by these Bidding Documents. On request, Owner will provide to each Bidder for examination access to or copies of contract documents (other than portions thereof related to price) for such other work.

- B. Paragraph 6.13.C of the General Conditions indicates that if an Owner safety program exists, it will be noted in the Supplementary Conditions.

- 4.07 It is the responsibility of each Bidder before submitting a Bid to:
- A. examine and carefully study the Bidding Documents, and the other related data identified in the Bidding Documents;
  - B. visit the Site and become familiar with and satisfy Bidder as to the general, local, and Site conditions that may affect cost, progress, and performance of the Work;
  - C. become familiar with and satisfy Bidder as to all federal, state, and local Laws and Regulations that may affect cost, progress, and performance of the Work;
  - D. carefully study all: (1) reports of explorations and tests of subsurface conditions at or contiguous to the Site and all drawings of physical conditions relating to existing surface or subsurface structures at the Site (except Underground Facilities) that have been identified in Paragraph 4.02 of the Supplementary Conditions as containing reliable "technical data," and (2) reports and drawings of Hazardous Environmental Conditions, if any, at the Site that have been identified in the Paragraph 4.06 of the Supplementary Conditions as containing reliable "technical data";
  - E. consider the information known to Bidder; information commonly known to contractors doing business in the locality of the Site; information and observations obtained from visits to the Site; the Bidding Documents; and the Site-related reports and drawings identified in the Bidding Documents, with respect to the effect of such information, observations, and documents on (1) the cost, progress, and performance of the Work; (2) the means, methods, techniques, sequences, and procedures of construction to be employed by Bidder, including applying any specific means, methods, techniques, sequences, and procedures of construction expressly required by the Bidding Documents; and (3) Bidder's safety precautions and programs;
  - F. agree at the time of submitting its Bid that no further examinations, investigations, explorations, tests, studies, or data are necessary for the determination of its Bid for performance of the Work at the price(s) bid and within the times required, and in accordance with the other terms and conditions of the Bidding Documents;
  - G. become aware of the general nature of the work to be performed by Owner and others at the Site that relates to the Work as indicated in the Bidding Documents;
  - H. promptly give Engineer written notice of all conflicts, errors, ambiguities, or discrepancies that Bidder discovers in the Bidding Documents and confirm that the written resolution thereof by Engineer is acceptable to Bidder; and
  - I. determine that the Bidding Documents are generally sufficient to indicate and convey understanding of all terms and conditions for the performance of the Work.

**J. correlate the information known to Bidder, information and observations obtained from visits to the Site, reports and drawings identified in the Bidding Documents, and all additional examinations, investigations, explorations, tests, studies, and data with the Bidding Documents;**

- 4.08 The submission of a Bid will constitute an incontrovertible representation by Bidder that Bidder has complied with every requirement of this Article 4, that without exception the Bid is premised upon performing and furnishing the Work required by the Bidding Documents and applying any specific means, methods, techniques, sequences, and procedures of construction that may be shown or indicated or expressly required by the Bidding Documents, that Bidder has given Engineer written notice of all conflicts, errors, ambiguities, and discrepancies that Bidder has discovered in the Bidding Documents and the written resolutions thereof by Engineer are acceptable to Bidder, and that the Bidding Documents are generally sufficient to indicate and convey understanding of all terms and conditions for performing and furnishing the Work.
- 4.09 The submission of a Bid will constitute an incontrovertible representation by Bidder that Bidder will take affirmative action in complying with all Federal and State requirements concerning fair employment and employment of the handicapped, and concerning the treatment of all employees, without discrimination by reason of race, color, religion, sex, national origin, or physical handicap.

#### **ARTICLE 5 – PRE-BID CONFERENCE**

This section intentionally deleted.

#### **ARTICLE 6 – SITE AND OTHER AREAS**

- 6.01 The Site is identified in the Bidding Documents. Easements for permanent structures or permanent changes in existing facilities are to be obtained and paid for by Owner unless otherwise provided in the Bidding Documents. All additional lands and access thereto required for temporary construction facilities, construction equipment, or storage of materials and equipment to be incorporated in the Work are to be obtained and paid for by Contractor.

#### **ARTICLE 7 – INTERPRETATIONS AND ADDENDA**

- 7.01 All questions about the meaning or intent of the Bidding Documents are to be submitted to the Office of the Procurement Manager in writing. **Questions may be emailed. Direct all questions to Cleve Haddock, CLGPO, Procurement Manager, at (252) 551-1533, [haddocgc@guc.com](mailto:haddocgc@guc.com). All questions regarding this bid must be received**



**in writing by or before 5:00PM (EDST) on February 25, 2021. Submittal with questions shall include the project name, the person's name submitting the question, firm, telephone number, and e-mail address.** Interpretations or clarifications considered necessary by Engineer in response to such questions will be issued by Addenda mailed or delivered to all parties recorded by Engineer as having received the Bidding Documents. Questions received after the date specified above may not be answered. Only questions answered by Addenda will be binding. Oral and other interpretations or clarifications will be without legal effect.

- 7.02 Addenda may be issued to clarify, correct, or change the Bidding Documents as deemed advisable by Owner or Engineer.

#### **ARTICLE 8 – BID SECURITY**

- 8.01 A Bid must be accompanied by Bid security made payable to Owner in an amount of 5 percent of Bidder's maximum Bid price and in the form of a certified check, bank money order, or a Bid bond (on the form attached) issued by a surety meeting the requirements of Paragraphs 5.01 and 5.02 of the General Conditions.
- 8.02 The Bid security of the Successful Bidder will be retained until such Bidder has executed the Contract Documents, furnished the required contract security and met the other conditions of the Notice of Award, whereupon the Bid security will be returned. If the Successful Bidder fails to execute and deliver the Contract Documents and furnish the required contract security within 15 days after the Notice of Award, Owner may consider Bidder to be in default, annul the Notice of Award, and the Bid security of that Bidder will be forfeited. Such forfeiture shall be Owner's exclusive remedy if Bidder defaults. The Bid security of other Bidders whom Owner believes to have a reasonable chance of receiving the award may be retained by Owner until the earlier of seven days after the Effective Date of the Agreement or to the end of the Bid holding period as indicated in the Bid, Article 2, whereupon Bid security furnished by such Bidders will be returned.
- 8.03 Bid security of other Bidders whom Owner believes do not have a reasonable chance of receiving the award will be returned within seven days after the Bid opening.

#### **ARTICLE 9 – CONTRACT TIMES**

- 9.01 The number of days within which, or the dates by which, [Milestones are to be achieved and] the Work is to be substantially completed and ready for final payment are set forth in the Agreement.

#### **ARTICLE 10 – LIQUIDATED DAMAGES**

- 10.01 Provisions for liquidated damages, if any, are set forth in the Agreement.

**ARTICLE 11 – SUBSTITUTE AND “OR-EQUAL” ITEMS**

11.01 The Contract, if awarded, will be on the basis of materials and equipment specified or described in the Bidding Documents without consideration of possible substitute or “or-equal” items. Whenever it is specified or described in the Bidding Documents that a substitute or “or-equal” item of material or equipment may be furnished or used by Contractor if acceptable to Engineer, application for such acceptance will not be considered by Engineer until after the Effective Date of the Agreement.

**ARTICLE 12 – SUBCONTRACTORS, SUPPLIERS AND OTHERS**

12.01 If the Supplementary Conditions require the identity of certain Subcontractors, Suppliers, individuals, or entities to be submitted to Owner in advance of a specified date prior to the Effective Date of the Agreement, the apparent Successful Bidder, and any other Bidder so requested, shall within five days after Bid opening, submit to Owner a list of all such Subcontractors, Suppliers, individuals, or entities proposed for those portions of the Work for which such identification is required. Such list shall be accompanied by an experience statement with pertinent information regarding similar projects and other evidence of qualification for each such Subcontractor, Supplier, individual, or entity if requested by Owner. If Owner or Engineer, after due investigation, has reasonable objection to any proposed Subcontractor, Supplier, individual, or entity, Owner may, before the Notice of Award is given, request apparent Successful Bidder to submit a substitute, without an increase in the Bid.

12.02 If apparent Successful Bidder declines to make any such substitution, Owner may award the Contract to the next lowest Bidder that proposes to use acceptable Subcontractors, Suppliers, individuals, or entities. Declining to make requested substitutions will not constitute grounds for forfeiture of the Bid security of any Bidder. Any Subcontractor, Supplier, individual, or entity so listed and against which Owner or Engineer makes no written objection prior to the giving of the Notice of Award will be deemed acceptable to Owner and Engineer subject to revocation of such acceptance after the Effective Date of the Agreement as provided in Paragraph 6.06 of the General Conditions.

12.03 Contractor shall not be required to employ any Subcontractor, Supplier, individual, or entity against whom Contractor has reasonable objection.

**12.04 The Contractor shall not award work to Subcontractor(s) in excess of the limits stated in SC 6.06.**

**ARTICLE 13 – PREPARATION OF BID**

13.01 The Bid Form is included with the Bidding Documents. Additional copies may be obtained from Engineer.

- 13.02 All blanks on the Bid Form shall be completed in ink, **by typewriter or printer** and the Bid Form signed in ink. Erasures or alterations shall be initialed in ink by the person signing the Bid Form. A Bid price shall be indicated for each [section, Bid item, alternative, adjustment unit price item, and unit price item] listed therein. In the case of optional alternatives the words “No Bid,” “No Change,” or “Not Applicable” may be entered.
- 13.03 A Bid by a corporation shall be executed in the corporate name by the president or a vice-president or other corporate officer accompanied by evidence of authority to sign. The corporate seal shall be affixed and attested by the secretary or an assistant secretary. The corporate address and state of incorporation shall be shown.
- 13.04 A Bid by a partnership shall be executed in the partnership name and signed by a partner (whose title must appear under the signature), accompanied by evidence of authority to sign. The official address of the partnership shall be shown.
- 13.05 A Bid by a limited liability company shall be executed in the name of the firm by a member and accompanied by evidence of authority to sign. The state of formation of the firm and the official address of the firm shall be shown.
- 13.06 A Bid by an individual shall show the Bidder’s name and official address.
- 13.07 A Bid by a joint venture shall be executed by each joint venturer in the manner indicated on the Bid Form. The official address of the joint venture shall be shown.
- 13.08 All names shall be printed in ink below the signatures.
- 13.09 The Bid shall contain an acknowledgment of receipt of all Addenda, the numbers of which shall be filled in on the Bid Form.
- 13.10 Postal and e-mail addresses and telephone number for communications regarding the Bid shall be shown.
- 13.11 The Bid shall contain evidence of Bidder’s authority and qualification to do business in the state where the Project is located, or Bidder shall covenant in writing to obtain such authority and qualification prior to award of the Contract and attach such covenant to the Bid. Bidder’s state contractor license number, if any, shall also be shown on the Bid Form.

## **ARTICLE 14 – BASIS OF BID; COMPARISON OF BIDS**

### 14.01 *Lump Sum*

- A. Bidders shall submit a Bid on a lump sum basis for the base Bid **items** and include a separate price for each alternate described in the Bidding Documents as provided for in the Bid Form. The price for each alternate will be the amount added to or deleted from the base Bid if Owner selects the alternate. **Discrepancies between the indicated sum of any column of figures and the correct sum thereof will be resolved in favor of the correct sum.**

#### 14.02 *Unit Price*

- A. Bidders shall submit a Bid on a unit price basis for each item of Work listed in the Bid schedule.
- B. The total of all estimated prices will be the sum of the products of the estimated quantity of each item and the corresponding unit price. The final quantities and Contract Price will be determined in accordance with Paragraph 11.03 of the General Conditions.
- C. Discrepancies between the multiplication of units of Work and unit prices will be resolved in favor of the unit prices. Discrepancies between the indicated sum of any column of figures and the correct sum thereof will be resolved in favor of the correct sum.
- D. Alternates to the Base Bid for unit price items shall replace the corresponding item in the Base Bid.**

#### 14.03 *Allowances*

- A. For cash allowances the Bid price shall include such amounts as the Bidder deems proper for Contractor's overhead, costs, profit, and other expenses on account of cash allowances, if any, named in the Contract Documents, in accordance with Paragraph 11.02.B of the General Conditions.

**ARTICLE 15 – SUBMITTAL OF BID**

**15.01 With each copy of the Bidding Documents, a Bidder is furnished one bound copy of the Bid Form, and all the attachments outlined in Article 7 of the Bid Form to be submitted. If provided by Addendum, an unbound copy of the Bid Form is to be completed and submitted with all the attachments outlined in Article 7 of the Bid Form.**

A. *[See BF-7.01 for a list of documents typically required to be submitted with the Bid.]*

**15.02 A Bid shall be submitted no later than the date and time prescribed and at the place indicated in the advertisement or invitation to bid and shall be enclosed in a plainly marked package with the Project title (and, if applicable, the designated portion of the Project for which the Bid is submitted), the name and address of Bidder, and shall be accompanied by the Bid security and other required documents. If a Bid is sent by mail or other delivery system, the sealed envelope containing the Bid shall be enclosed in a separate package plainly marked on the outside with the notation "BID ENCLOSED." A mailed Bid shall be addressed as indicated in the Advertisement.**

**ARTICLE 16 – MODIFICATION AND WITHDRAWAL OF BID**

**16.01 A Bid may be modified or withdrawn by an appropriate document duly executed in the same manner that a Bid must be executed and delivered to the place where Bids are to be submitted prior to the date and time for the opening of Bids.**

**16.02 If, within seventy-two hours after Bids are opened, not including weekends and holidays legally recognized by the OWNER, any BIDDER files a duly signed, written notice with OWNER and promptly thereafter demonstrates to the reasonable satisfaction of OWNER that there was a material and substantial mistake in the preparation of its Bid, that BIDDER may withdraw its Bid and the Bid security will be returned in accordance with North Carolina G.S. 143-129.1. Thereafter, that BIDDER will be disqualified from further bidding on the Work to be provided under the Contract Documents.**

**ARTICLE 17 – OPENING OF BIDS**

**17.01 Bids will be opened at the time and place indicated in the Advertisement or Invitation to Bid. A record of the amounts of the base Bids and major alternates, if any, will be kept by the Procurement Manager and made available to Bidders after the contract has been awarded.**

**ARTICLE 18 - BIDS TO REMAIN SUBJECT TO ACCEPTANCE**

18.01 All Bids will remain subject to acceptance for the period of time stated in the Bid Form, but Owner may, in its sole discretion, release any Bid and return the Bid security prior to the end of this period.

**ARTICLE 19 – EVALUATION OF BIDS AND AWARD OF CONTRACT**

19.01 Owner reserves the right to reject any or all Bids, including without limitation, nonconforming, nonresponsive, unbalanced, or conditional Bids. Owner further reserves the right to reject the Bid of any Bidder whom it finds, after reasonable inquiry and evaluation, to not be responsible. Owner may also reject the Bid of any Bidder if Owner believes that it would not be in the best interest of the Project to make an award to that Bidder. Owner also reserves the right to waive all informalities not involving price, time, or changes in the Work and to negotiate contract terms with the Successful Bidder.

19.02 More than one Bid for the same Work from an individual or entity under the same or different names will not be considered. Reasonable grounds for believing that any Bidder has an interest in more than one Bid for the Work may be cause for disqualification of that Bidder and the rejection of all Bids in which that Bidder has an interest.

19.03 In evaluating Bids, Owner will consider whether or not the Bids comply with the prescribed requirements, and such alternates, unit prices and other data, as may be requested in the Bid Form or prior to the Notice of Award.

19.04 In evaluating Bidders, Owner will consider the qualifications of Bidders and may consider the qualifications and experience of Subcontractors, Suppliers, and other individuals or entities proposed for those portions of the Work for which the identity of Subcontractors, Suppliers, and other individuals or entities must be submitted as provided in the Supplementary Conditions.

19.05 Owner may conduct such investigations as Owner deems necessary to establish the responsibility, qualifications, and financial ability of Bidders, proposed Subcontractors, Suppliers, individuals, or entities proposed for those portions of the Work in accordance with the Contract Documents.

19.06 If the Contract is to be awarded, Owner will award the Contract to the Bidder whose Bid is in the best interests of the Project.

**19.07 In determining the lowest responsible Bidder, as directed by statute, Owner will evaluate qualified bids taking into consideration the past performance of Bidder on**

**construction contracts with particular concern given to completion times, quality of work, cooperation with other Contractors, and cooperation with Owner.**

- 19.08 Owner reserves the right to reject Bid if the evidence submitted by, or investigation of, such Bidder fails to satisfy Owner that such Bidder is properly qualified to carry out the obligations of the Agreement and to complete the Work described therein.**
- 19.09 Should the Owner adjudge that the apparent low Bidder is not the lowest responsible Bidder by virtue of the above information, said apparent low Bidder will be so notified and his Bid security shall be returned.**
- 19.10 Bid award will be evaluated on the total of the base bid and the alternates as selected by the Owner to the extent that project funds are available.**
- 19.11 The Owner reserves the right to award any or all parts of a Contract but separate parts of the same Contract will not be awarded to different contractors.**
- 19.12 Contracts funded with federal grant or loan funds must be procured in a manner that conforms with all applicable federal laws, policies, and standards, including those under the Uniform Guidance (2 C.F.R. Part 200).**

## **ARTICLE 20 – CONTRACT SECURITY AND INSURANCE**

- 20.01 Article 5 of the General Conditions, as may be modified by the Supplementary Conditions, sets forth Owner’s requirements as to insurance. When the Successful Bidder delivers the executed Agreement to Owner, it shall be accompanied by such insurance certificates.

## **ARTICLE 21 – SIGNING OF AGREEMENT**

- 21.01 When Owner issues a Notice of Award to the Successful Bidder, it shall be accompanied by the required number of unsigned counterparts of the Agreement along with the other Contract Documents which are identified in the Agreement as attached thereto. Within 15 days thereafter, Successful Bidder shall sign and deliver the required number of counterparts of the Agreement and attached documents to Owner. Within ten days thereafter, Owner shall deliver one fully signed counterpart to Successful Bidder with a complete set of the Drawings with appropriate identification.

## **ARTICLE 23 – RETAINAGE**

- 23.01 **Refer to Agreement 00520.**

## **END OF INSTRUCTIONS TO BIDDERS**





## **BID FORM**

### **PROJECT IDENTIFICATION:**

#### **NORTHSIDE COMMERCIAL CENTER SANITARY SEWER ESTENSION**

### **TABLE OF CONTENTS**

Article 1 – Bid Recipient

Article 2 – Bidder’s Acknowledgements

Article 3 – Bidder’s Representations

Article 4 – Bidder’s Certification

Article 5 – Basis of Bid

Article 6 – Time of Completion

Article 7 – Attachments to This Bid

Article 8 – Defined Terms

Article 9 – Bid Submittal

### **ARTICLE 1 – BID RECIPIENT**

1.01 This Bid is submitted to:

#### **GREENVILLE UTILITIES COMMISSION**

1.02 The undersigned Bidder proposes and agrees, if this Bid is accepted, to enter into an Agreement with Owner in the form included in the Bidding Documents to perform all Work as specified or indicated in the Bidding Documents for the prices and within the times indicated in this Bid and in accordance with the other terms and conditions of the Bidding Documents.

**ARTICLE 2 – BIDDER’S ACKNOWLEDGEMENTS**

2.01 Bidder accepts all of the terms and conditions of the Instructions to Bidders, including without limitation those dealing with the disposition of Bid security. This Bid will remain subject to acceptance for 60 days after the Bid opening, or for such longer period of time that Bidder may agree to in writing upon request of Owner.

**ARTICLE 3 – BIDDER’S REPRESENTATIONS**

3.01 In submitting this Bid, Bidder represents that:

A. Bidder has examined and carefully studied the Bidding Documents, other related data identified in the Bidding Documents, and the following Addenda, receipt of which is hereby acknowledged:

| <u>Addendum No.</u> | <u>Addendum Date</u> |
|---------------------|----------------------|
| _____               | _____                |
| _____               | _____                |
| _____               | _____                |
| _____               | _____                |

B. Bidder has visited the Site and become familiar with and is satisfied as to the general, local, and Site conditions that may affect cost, progress, and performance of the Work.

C. Bidder is familiar with and is satisfied as to all Laws and Regulations that may affect cost, progress, and performance of the Work.

D. Bidder has carefully studied all: (1) reports of explorations and tests of subsurface conditions at or contiguous to the Site and all drawings of physical conditions relating to existing surface or subsurface structures at the Site (except Underground Facilities) that have been identified in SC-4.02 as containing reliable "technical data," and (2) reports and drawings of Hazardous Environmental Conditions, if any, at the Site that have been identified in SC-4.06 as containing reliable "technical data."

E. Bidder has considered the information known to Bidder; information commonly known to contractors doing business in the locality of the Site; information and observations obtained from visits to the Site; the Bidding Documents; and the Site-related reports and drawings identified in the Bidding Documents, with respect to the effect of such information, observations, and documents on (1) the cost, progress, and performance of the Work; (2) the means, methods, techniques, sequences, and procedures of construction to be employed by Bidder, including applying the specific

- means, methods, techniques, sequences, and procedures of construction expressly required by the Bidding Documents; and (3) Bidder's safety precautions and programs.
- F. Based on the information and observations referred to in Paragraph 3.01.E above, Bidder does not consider that further examinations, investigations, explorations, tests, studies, or data are necessary for the determination of this Bid for performance of the Work at the price(s) bid and within the times required, and in accordance with the other terms and conditions of the Bidding Documents.
  - G. Bidder is aware of the general nature of work to be performed by Owner and others at the Site that relates to the Work as indicated in the Bidding Documents.
  - H. Bidder has given Engineer written notice of all conflicts, errors, ambiguities, or discrepancies that Bidder has discovered in the Bidding Documents, and the written resolution thereof by Engineer is acceptable to Bidder.
  - I. The Bidding Documents are generally sufficient to indicate and convey understanding of all terms and conditions for the performance of the Work for which this Bid is submitted.
  - J. **Bidder has correlated the information known to Bidder, information and observations obtained from visits to the Site, reports and drawings identified in the Bidding Documents, and all additional examinations, investigations, explorations, tests, studies, and data with the Bidding Documents.**

#### ARTICLE 4 - BIDDER'S CERTIFICATION

4.01 Bidder certifies that:

- A. This Bid is genuine and not made in the interest of or on behalf of any undisclosed individual or entity and is not submitted in conformity with any collusive agreement or rules of any group, association, organization, or corporation;
- B. Bidder has not directly or indirectly induced or solicited any other Bidder to submit a false or sham Bid;
- C. Bidder has not solicited or induced any individual or entity to refrain from bidding; and
- D. Bidder has not engaged in corrupt, fraudulent, collusive, or coercive practices in competing for the Contract. For the purposes of this Paragraph 4.01.D:
  - 1. "corrupt practice" means the offering, giving, receiving, or soliciting of any thing of value likely to influence the action of a public official in the bidding process;

2. “fraudulent practice” means an intentional misrepresentation of facts made (a) to influence the bidding process to the detriment of Owner, (b) to establish bid prices at artificial non-competitive levels, or (c) to deprive Owner of the benefits of free and open competition;
3. “collusive practice” means a scheme or arrangement between two or more Bidders, with or without the knowledge of Owner, a purpose of which is to establish bid prices at artificial, non-competitive levels; and
4. “coercive practice” means harming or threatening to harm, directly or indirectly, persons or their property to influence their participation in the bidding process or affect the execution of the Contract.

## **ARTICLE 5 – BASIS OF BID**

- 5.01 Bidder will complete the Work in accordance with the Contract Documents for the following price(s) on the Bid Schedule.
- A. All specified cash allowances are included in the price(s) set forth in the Bid Schedule and have been computed in accordance with Paragraph 11.02 of the General Conditions.
  - B. Unit Prices have been computed in accordance with Paragraph 11.03.B of the General Conditions.
  - C. Bidder acknowledges that estimated quantities are not guaranteed, and are solely for the purpose of comparison of Bids, and final payment for all unit price Bid items will be based on actual quantities, determined as provided in the Contract Documents.

**BID SCHEDULE**

| <b>ITEM NO.</b>       | <b>DESCRIPTION</b>                             | <b>TOTAL PRICE</b> |
|-----------------------|--|--------------------|
| I                     | Utility Construction                           | _____              |
| II                    | Soils & Materials Testing Allowance            | <u>\$2,500.00</u>  |
| III                   | Septic System Investigation / Repair Allowance | <u>\$5,000.00</u>  |
| <b>TOTAL BASE BID</b> |  | _____              |

(Total Base Bid Includes 120 CY of Undercut Excavation w/ Off-Site Disposal,  
120 CY of Select Backfill Excavation and 50 TN of Stabilization Stone)

**UNIT PRICES**

|   |              |
|---|--------------|
| 1. Undercut Excavation w/ Off-site Disposal | \$ _____ /CY |
| 2. Select Backfill Excavation               | \$ _____ /CY |
| 3. Stabilization Stone                      | \$ _____ /CY |

**ARTICLE 6 – TIME OF COMPLETION**

- 6.01 Bidder agrees that the Work will be substantially complete and will be completed and ready for final payment in accordance with Paragraph 14.07 of the General Conditions on or before the dates or within the number of calendar days indicated in the Agreement.
- 6.02 Bidder accepts the provisions of the Agreement as to liquidated damages in the event of failure to complete the Work within the Contract Times.
- 6.03 Refer to the Agreement for Milestones that must be met and liquidated damages in the event of failure to complete the Work within the Contract Times for the Milestones.

**ARTICLE 7 – ATTACHMENTS TO THIS BID**

- 7.01 The following documents are submitted with and made a condition of this Bid. Failure to provide the documentation with the Bid may be grounds for rejection of the Bid.
- A. Addenda
  - B. Bid Security in accordance with Article 8 of the Instructions to Bidders
  - C. Minority/Women Business Participation Documents
  - D. E-Verify Letter of Compliance
- 7.04 After the Bid opening, the Bidder will supply the information for Qualification of Bidders, as required in Article 3 of the Instructions to Bidders, within 5 days of the Owner's request.

**ARTICLE 8 – DEFINED TERMS**

- 8.01 The terms used in this Bid with initial capital letters have the meanings stated in the Instructions to Bidders, the General Conditions, and the Supplementary Conditions.

*Bid Schedule* – The Bid Schedule includes the Bidder's prices and is part of Article 5 – Basis of Bid in the Bid Form.

**ARTICLE 9 – BID SUBMITTAL**

9.01 This Bid is submitted by:

If Bidder is:

An Individual

Name (typed or printed): \_\_\_\_\_

By: \_\_\_\_\_  
(Individual's signature)

Doing business as: \_\_\_\_\_

A Partnership

Partnership Name: \_\_\_\_\_

By: \_\_\_\_\_  
(Signature of general partner -- attach evidence of authority to sign)

Name (typed or printed): \_\_\_\_\_

A Corporation

Corporation Name: \_\_\_\_\_ (SEAL)

State of Incorporation: \_\_\_\_\_

Type (General Business, Professional, Service, Limited Liability): \_\_\_\_\_

By: \_\_\_\_\_  
(Signature -- attach evidence of authority to sign)

Name (typed or printed): \_\_\_\_\_

Title: \_\_\_\_\_  
(CORPORATE SEAL)

Attest \_\_\_\_\_

Date of Qualification to do business in \_\_\_\_\_ is \_\_\_/\_\_\_/\_\_\_\_\_.

A Joint Venture

Name of Joint Venture: \_\_\_\_\_

First Joint Venturer Name: \_\_\_\_\_ (SEAL)

By: \_\_\_\_\_  
(Signature of first joint venture partner--attach evidence of authority to sign)

Name (typed or printed): \_\_\_\_\_

Title: \_\_\_\_\_

Second Joint Venturer Name: \_\_\_\_\_ (SEAL)

By: \_\_\_\_\_  
(Signature of second joint venture partner--attach evidence of authority to sign)

Name (typed or printed): \_\_\_\_\_

Title: \_\_\_\_\_

(Each joint venturer must sign. The manner of signing for each individual, partnership, and corporation that is a party to the joint venture should be in the manner indicated above.)

Bidder's Business Address \_\_\_\_\_  
\_\_\_\_\_

Phone No. \_\_\_\_\_ Fax No. \_\_\_\_\_

E-mail \_\_\_\_\_

SUBMITTED on \_\_\_\_\_, 20\_\_\_\_.

State Contractor License No. \_\_\_\_\_

Contractor's Classification: \_\_\_\_\_

Contractor's Limitation: \_\_\_\_\_

Employer's Tax ID No.: \_\_\_\_\_



### BID BOND

Any singular reference to Bidder, Surety, Owner or other party shall be considered plural where applicable.

BIDDER *(Name and Address):*

SURETY *(Name and Address of Principal Place of Business):*

OWNER *(Name and Address):*

Greenville Utilities Commission  
401 S. Greene St.  
Greenville, NC 27834

BID

Bid Due Date:

Description *(Project Name and Include Location):*

Northside Commercial Center, Sanitary Sewer Extension, Greenville Twsp., Pitt County, NC

BOND

Bond Number:

Date *(Not earlier than Bid due date):*

Penal sum \_\_\_\_\_ \$ \_\_\_\_\_  
(Words) (Figures)

Surety and Bidder, intending to be legally bound hereby, subject to the terms set forth below, do each cause this Bid Bond to be duly executed by an authorized officer, agent, or representative.

**BIDDER**

**SURETY**

\_\_\_\_\_  
Bidder's Name and Corporate Seal (Seal)

\_\_\_\_\_  
Surety's Name and Corporate Seal (Seal)

By: \_\_\_\_\_  
Signature

By: \_\_\_\_\_  
Signature (Attach Power of Attorney)

\_\_\_\_\_  
Print Name

\_\_\_\_\_  
Print Name

\_\_\_\_\_  
Title

\_\_\_\_\_  
Title

Attest: \_\_\_\_\_  
Signature

Attest: \_\_\_\_\_  
Signature

\_\_\_\_\_  
Title

\_\_\_\_\_  
Title

*Note: Above addresses are to be used for giving any required notice. Provide execution by any additional parties, such as joint venturers, if necessary.*

1. Bidder and Surety, jointly and severally, bind themselves, their heirs, executors, administrators, successors, and assigns to pay to Owner upon default of Bidder the penal sum set forth on the face of this Bond. Payment of the penal sum is the extent of Bidder's and Surety's liability. Recovery of such penal sum under the terms of this Bond shall be Owner's sole and exclusive remedy upon default of Bidder.
2. Default of Bidder shall occur upon the failure of Bidder to deliver within the time required by the Bidding Documents (or any extension thereof agreed to in writing by Owner) the executed Agreement required by the Bidding Documents and any performance and payment bonds required by the Bidding Documents.
3. This obligation shall be null and void if:
  - 3.1 Owner accepts Bidder's Bid and Bidder delivers within the time required by the Bidding Documents (or any extension thereof agreed to in writing by Owner) the executed Agreement required by the Bidding Documents and any performance and payment bonds required by the Bidding Documents, or
  - 3.2 All Bids are rejected by Owner, or
  - 3.3 Owner fails to issue a Notice of Award to Bidder within the time specified in the Bidding Documents (or any extension thereof agreed to in writing by Bidder and, if applicable, consented to by Surety when required by Paragraph 5 hereof).
4. Payment under this Bond will be due and payable upon default of Bidder and within 30 calendar days after receipt by Bidder and Surety of written notice of default from Owner, which notice will be given with reasonable promptness, identifying this Bond and the Project and including a statement of the amount due.
5. Surety waives notice of any and all defenses based on or arising out of any time extension to issue Notice of Award agreed to in writing by Owner and Bidder, provided that the total time for issuing Notice of Award including extensions shall not in the aggregate exceed 120 days from Bid due date without Surety's written consent.
6. No suit or action shall be commenced under this Bond prior to 30 calendar days after the notice of default required in Paragraph 4 above is received by Bidder and Surety and in no case later than one year after Bid due date.
7. Any suit or action under this Bond shall be commenced only in a court of competent jurisdiction located in the state in which the Project is located.
8. Notices required hereunder shall be in writing and sent to Bidder and Surety at their respective addresses shown on the face of this Bond. Such notices may be sent by personal delivery, commercial courier, or by United States Registered or Certified Mail, return receipt requested, postage pre-paid, and shall be deemed to be effective upon receipt by the party concerned.
9. Surety shall cause to be attached to this Bond a current and effective Power of Attorney evidencing the authority of the officer, agent, or representative who executed this Bond on behalf of Surety to execute, seal, and deliver such Bond and bind the Surety thereby.

10. This Bond is intended to conform to all applicable statutory requirements. Any applicable requirement of any applicable statute that has been omitted from this Bond shall be deemed to be included herein as if set forth at length. If any provision of this Bond conflicts with any applicable statute, then the provision of said statute shall govern and the remainder of this Bond that is not in conflict therewith shall continue in full force and effect.

11. The term "Bid" as used herein includes a Bid, offer, or proposal as applicable.



## **Special Instructions to Bidders**

### **City of Greenville/Greenville Utilities Commission Minority and/or Women Business Enterprise (M/WBE) Program**

#### **GUC Construction Guidelines and Affidavits \$100,000 and above**

These instructions shall be included with each bid solicitation.

## City of Greenville/Greenville Utilities Commission Minority and/or Women Business Enterprise Program

### \$100,000 and Construction Guidelines for M/WBE Participants

**Policy Statement**

It is the policy of the City of Greenville and Greenville Utilities Commission to provide minorities and women equal opportunity for participating in all aspects of the City’s and Utilities’ contracting and procurement programs, including but not limited to, construction projects, supplies and materials purchases, and professional and personal service contracts.

**Goals and Good Faith Efforts**

Bidders responding to this solicitation shall comply with the M/WBE program by making Good Faith Efforts to achieve the following aspiration goals for participation.

|  | GUC |     |
|--|-----|-----|
|  | MBE | WBE |
| <b>Construction</b> This goal includes Construction Manager at Risk. | 7%  | 4%  |

Bidders shall submit M/WBE information with their bids on the forms provided. This information will be subject to verification by GUC prior to contract award. **As of July 1, 2009, contractors, subcontractors, suppliers, service providers, or M/WBE members of joint ventures intended to satisfy GUC M/WBE goals shall be certified by the NC Office of Historically Underutilized Businesses (NC HUB) only.** Firms qualifying as “WBE” for GUC’s goals must be designated as a “women-owned business” by the HUB Office. Firms qualifying as “MBE” for the GUC’s goals must be certified in one of the other categories (i.e.: Black, Hispanic, Asian American, American Indian, Disabled, or Socially and Economically Disadvantaged). Those firms who are certified as both a “WBE” and “MBE” may only satisfy the “MBE” requirement. A complete database of NC HUB certified firms may be found at <http://www.doa.nc.gov/hub/>. An internal database of firms who have expressed interest to do business with the City and GUC is available at [www.greenvillencmwbe.org](http://www.greenvillencmwbe.org). However, the HUB status of these firms must be verified by the HUB database. GUC shall accept NCDOT certified firms on federally funded projects only. Please note: A contractor may utilize any firm desired. However, for participation purposes, all M/WBE vendors who wish to do business as a minority or a female must be certified by NC HUB.

The Bidder shall make good faith efforts to encourage participation of M/WBEs prior to submission of bids in order to be considered as a responsive bidder. Bidders are cautioned that even though their submittal indicates they will meet the M/WBE goal, they should document their good faith efforts and be prepared to submit this information, if requested.

The M/WBE’s listed by the Contractor on the **Identification of Minority/Women Business Participation** which are determined by the GUC to be certified shall perform the work and supply the materials for which they are listed unless the Contractors receive prior authorization from the GUC to perform the work with other forces or to obtain materials from other sources. If a contractor is proposing to perform all elements of the work with his own forces, he must be prepared to document evidence satisfactory to the owner of similar government contracts where he has self-performed.

The Contractor shall enter into and supply copies of fully executed subcontracts with each M/WBE or supply signed Letter(s) of Intent to the Project Manager after award of contract and prior to Notice to Proceed. Any amendments to subcontracts shall be submitted to the Project Manager prior to execution.

## Instructions

The Bidder shall provide with the bid the following documentation:

Identification of Minority/Women Business Participation  
(if participation is zero, please mark zero—Blank forms will be considered nonresponsive)

Affidavit A (if subcontracting)

OR

Identification of Minority/Women Business Participation  
(if participation is zero, please mark zero—Blank forms will be considered nonresponsive)

Affidavit B (if self-performing; must attest that bidder does not customarily subcontract work on this type of project—includes supplies and materials)

Within 72 hours or 3 business days after notification of being the apparent low bidder who is subcontracting anything must provide the following information:

Affidavit C (if aspirational goals are met or are exceeded)

OR

Affidavit D (if aspirational goals are not met)

After award of contract and prior to issuance of notice to proceed:

Letter(s) of Intent or Executed Contracts

**\*\*With each pay request, the prime contractors will submit the Proof of Payment Certification, listing payments made to M/WBE subcontractors.**

**\*\*\*If a change is needed in M/WBE Participation, submit a Request to Change M/WBE Participation Form. Good Faith Efforts to substitute with another M/WBE contractor must be demonstrated.**

### Minimum Compliance Requirements:

**All written statements, affidavits, or intentions made by the Bidder shall become a part of the agreement between the Contractor and the GUC for performance of contracts. Failure to comply with any of these statements, affidavits or intentions or with the minority business guidelines shall constitute a breach of the contract. A finding by the GUC that any information submitted (either prior to award of the contract or during the performance of the contract) is inaccurate, false, or incomplete, shall also constitute a breach of the contract. Any such breach may result in termination of the contract in accordance with the termination provisions contained in the contract. It shall be solely at the option of the GUC whether to terminate the contract for breach or not. In determining whether a contractor has made Good Faith Efforts, the GUC will evaluate all efforts made by the Contractor and will determine compliance in regard to quantity, intensity, and results of these efforts.**





## Identification of Minority/Women Business Participation

I, \_\_\_\_\_, \_\_\_\_\_  
 (Name of Bidder)

do hereby certify that on this project, we will use the following minority/women business enterprises as construction subcontractors, vendors, suppliers or providers of professional services.

| Firm Name, Address and Phone # | Work type | *M/WBE Category |
|--------------------------------|-----------|-----------------|
|                                |           |                 |
|                                |           |                 |
|                                |           |                 |
|                                |           |                 |
|                                |           |                 |
|                                |           |                 |
|                                |           |                 |
|                                |           |                 |
|                                |           |                 |
|                                |           |                 |
|                                |           |                 |
|                                |           |                 |
|                                |           |                 |
|                                |           |                 |
|                                |           |                 |
|                                |           |                 |
|                                |           |                 |
|                                |           |                 |
|                                |           |                 |
|                                |           |                 |
|                                |           |                 |
|                                |           |                 |
|                                |           |                 |
|                                |           |                 |

\*M/WBE categories: Black, African American (**B**), Hispanic, Latino (**L**), Asian American (**A**) American Indian (**I**), Female (**F**) Socially and Economically Disadvantaged (**S**) Disabled (**D**)

**If you will not be utilizing M/WBE contractors, please certify by entering zero “0”**

**The total value of MBE business contracting will be (\$) \_\_\_\_\_.**

**The total value of WBE business contracting will be (\$) \_\_\_\_\_.**



# Greenville Utilities Commission **AFFIDAVIT A – Listing of Good Faith Efforts**

County of \_\_\_\_\_

(Name of Bidder)

Affidavit of \_\_\_\_\_

I have made a good faith effort to comply under the following areas checked:

**Bidders must earn at least 50 points from the good faith efforts listed for their bid to be considered responsive.** (1 NC Administrative Code 30 I.0101)

- 1 – (10 pts)** Contacted minority businesses that reasonably could have been expected to submit a quote and that were known to the contractor, or available on State or local government maintained lists, at least 10 days before the bid date and notified them of the nature and scope of the work to be performed.
- 2 --(10 pts)** Made the construction plans, specifications and requirements available for review by prospective minority businesses, or providing these documents to them at least 10 days before the bids are due.
- 3 – (15 pts)** Broken down or combined elements of work into economically feasible units to facilitate minority participation.
- 4 – (10 pts)** Worked with minority trade, community, or contractor organizations identified by the Office of Historically Underutilized Businesses and included in the bid documents that provide assistance in recruitment of minority businesses.
- 5 – (10 pts)** Attended prebid meetings scheduled by the public owner.
- 6 – (20 pts)** Provided assistance in getting required bonding or insurance or provided alternatives to bonding or insurance for subcontractors.
- 7 – (15 pts)** Negotiated in good faith with interested minority businesses and did not reject them as unqualified without sound reasons based on their capabilities. Any rejection of a minority business based on lack of qualification should have the reasons documented in writing.
- 8 – (25 pts)** Provided assistance to an otherwise qualified minority business in need of equipment, loan capital, lines of credit, or joint pay agreements to secure loans, supplies, or letters of credit, including waiving credit that is ordinarily required. Assisted minority businesses in obtaining the same unit pricing with the bidder's suppliers in order to help minority businesses in establishing credit.
- 9 – (20 pts)** Negotiated joint venture and partnership arrangements with minority businesses in order to increase opportunities for minority business participation on a public construction or repair project when possible.
- 10 - (20 pts)** Provided quick pay agreements and policies to enable minority contractors and suppliers to meet cash-flow demands.

The undersigned, if apparent low bidder, will enter into a formal agreement with the firms listed in the Identification of Minority/Women Business Participation schedule conditional upon scope of contract to be executed with the Owner. Substitution of contractors must be in accordance with GS143-128.2(d) Failure to abide by this statutory provision will constitute a breach of the contract.

The undersigned hereby certifies that he or she has read the terms of the minority/women business commitment and is authorized to bind the bidder to the commitment herein set forth.

Date: \_\_\_\_\_ Name of Authorized Officer: \_\_\_\_\_

Signature: \_\_\_\_\_

Title: \_\_\_\_\_



State of \_\_\_\_\_, County of \_\_\_\_\_

Subscribed and sworn to before me this \_\_\_\_\_ day of \_\_\_\_\_ 20\_\_\_\_

Notary Public \_\_\_\_\_

My commission expires \_\_\_\_\_



# Greenville Utilities Commission --AFFIDAVIT B-- Intent to Perform Contract with Own Workforce.

County of \_\_\_\_\_

Affidavit of \_\_\_\_\_

(Name of Bidder)

I hereby certify that it is our intent to perform 100% of the work required for the \_\_\_\_\_

\_\_\_\_\_ contract.

(Name of Project)

In making this certification, the Bidder states that the Bidder does not customarily subcontract elements of this type project, and normally performs and has the capability to perform and will perform all elements of the work on this project with his/her own current work forces; and

The Bidder agrees to provide any additional information or documentation requested by the owner in support of the above statement.

The undersigned hereby certifies that he or she has read this certification and is authorized to bind the Bidder to the commitments herein contained.

Date: \_\_\_\_\_ Name of Authorized Officer: \_\_\_\_\_

Signature: \_\_\_\_\_

Title: \_\_\_\_\_



State of \_\_\_\_\_, County of \_\_\_\_\_

Subscribed and sworn to before me this \_\_\_\_\_ day of \_\_\_\_\_ 20\_\_

Notary Public \_\_\_\_\_

My commission expires \_\_\_\_\_



# Greenville Utilities Commission - AFFIDAVIT C - Portion of the Work to be Performed by M/WBE Firms

County of \_\_\_\_\_

(Note this form is to be submitted only by the apparent lowest responsible, responsive bidder.)

If the portion of the work to be executed by M/WBE businesses as defined in GS143-128.2(g) and the COG/GUC M/WBE Plan sec. III is equal to or greater than 11% of the bidders total contract price, then the bidder must complete this affidavit. This affidavit shall be provided by the apparent lowest responsible, responsive bidder within **72 hours** after notification of being low bidder.

Affidavit of \_\_\_\_\_ I do hereby certify that on the \_\_\_\_\_  
(Name of Bidder)

Project ID# \_\_\_\_\_ (Project Name) Amount of Bid \$ \_\_\_\_\_

I will expend a minimum of \_\_\_\_\_% of the total dollar amount of the contract with minority business enterprises and a minimum of \_\_\_\_\_% of the total dollar amount of the contract with women business enterprises. Minority/women businesses will be employed as construction subcontractors, vendors, suppliers or providers of professional services. Such work will be subcontracted to the following firms listed below. Attach additional sheets if required

| Name and Phone Number | *M/WBE Category | Work description | Dollar Value |
|-----------------------|-----------------|------------------|--------------|
|                       |                 |                  |              |
|                       |                 |                  |              |
|                       |                 |                  |              |
|                       |                 |                  |              |
|                       |                 |                  |              |
|                       |                 |                  |              |
|                       |                 |                  |              |
|                       |                 |                  |              |
|                       |                 |                  |              |
|                       |                 |                  |              |

\*Minority categories: Black, African American (B), Hispanic or Latino (L), Asian American (A) American Indian (I), Female (F) Socially and Economically Disadvantaged (S) Disabled (D)

Pursuant to GS143-128.2(d), the undersigned will enter into a formal agreement with M/WBE Firms for work listed in this schedule conditional upon execution of a contract with the Owner. Failure to fulfill this commitment may constitute a breach of the contract.

The undersigned hereby certifies that he or she has read the terms of this commitment and is authorized to bind the bidder to the commitment herein set forth.

Date: \_\_\_\_\_ Name of Authorized Officer: \_\_\_\_\_

Signature: \_\_\_\_\_

Title: \_\_\_\_\_



State of \_\_\_\_\_, County of \_\_\_\_\_  
Subscribed and sworn to before me this \_\_\_\_\_ day of \_\_\_\_\_ 20\_\_\_\_  
Notary Public \_\_\_\_\_  
My commission expires \_\_\_\_\_





# Greenville Utilities Commission **AFFIDAVIT D – Good Faith Efforts**

County of \_\_\_\_\_

(Note this form is to be submitted only by the apparent lowest responsible, responsive bidder.)

If the goal of 11% participation by minority/women business **is not** achieved, the Bidder shall provide the following documentation to the Owner of his good faith efforts:

Affidavit of \_\_\_\_\_ I do hereby certify that on the \_\_\_\_\_

(Name of Bidder)

Project ID# \_\_\_\_\_ (Project Name) \_\_\_\_\_ Amount of Bid \$ \_\_\_\_\_

I will expend a minimum of \_\_\_\_\_% of the total dollar amount of the contract with minority business enterprises and a minimum of \_\_\_\_\_% of the total dollar amount of the contract with women business enterprises. Minority/women businesses will be employed as construction subcontractors, vendors, suppliers or providers of professional services. Such work will be subcontracted to the following firms listed below. (Attach additional sheets if required)

| Name and Phone Number | *M/WBE Category | Work description | Dollar Value |
|-----------------------|-----------------|------------------|--------------|
|                       |                 |                  |              |
|                       |                 |                  |              |
|                       |                 |                  |              |
|                       |                 |                  |              |
|                       |                 |                  |              |

\*Minority categories: Black, African American (**B**), Hispanic or Latino (**L**), Asian American (**A**) American Indian (**I**), Female (**F**) Socially and Economically Disadvantaged (**S**) Disabled (**D**)

**Examples** of documentation required to demonstrate the Bidder's good faith efforts to meet the goals set forth in these provisions include, but are not necessarily limited to, the following:

- A. Copies of solicitations for quotes to at least three (3) minority business firms from the source list provided by the State for each subcontract to be let under this contract (if 3 or more firms are shown on the source list). Each solicitation shall contain a specific description of the work to be subcontracted, location where bid documents can be reviewed, representative of the Prime Bidder to contact, and location, date and time when quotes must be received.
- B. Copies of quotes or responses received from each firm responding to the solicitation.
- C. A telephone log of follow-up calls to each firm sent a solicitation.
- D. For subcontracts where a minority business firm is not considered the lowest responsible sub-bidder, copies of quotes received from all firms submitting quotes for that particular subcontract.
- E. Documentation of any contacts or correspondence to minority business, community, or contractor organizations in an attempt to meet the goal.
- F. Copy of pre-bid roster.
- G. Letter documenting efforts to provide assistance in obtaining required bonding or insurance for minority business.
- H. Letter detailing reasons for rejection of minority business due to lack of qualification.
- I. Letter documenting proposed assistance offered to minority business in need of equipment, loan capital, lines of credit, or joint pay agreements to secure loans, supplies, or letter of credit, including waiving credit that is ordinarily required.

Failure to provide the documentation as listed in these provisions may result in rejection of the bid and award to the next lowest responsible and responsive bidder.

Pursuant to GS143-128.2(d), the undersigned will enter into a formal agreement with M/WBE Firms for work listed in this schedule conditional upon execution of a contract with the Owner. Failure to fulfill this commitment may constitute a breach of the contract.

The undersigned hereby certifies that he or she has read the terms of this commitment and is authorized to bind the bidder to the commitment herein set forth.

Date: \_\_\_\_\_ Name of Authorized Officer: \_\_\_\_\_

Signature: \_\_\_\_\_

Title: \_\_\_\_\_



State of \_\_\_\_\_, County of \_\_\_\_\_

Subscribed and sworn to before me this \_\_\_\_\_ day of \_\_\_\_\_ 20\_\_\_\_

Notary Public \_\_\_\_\_

My commission expires \_\_\_\_\_

## LETTER OF INTENT M/WBE Subcontractor Performance

**Please submit this form or executed subcontracts with M/WBE firms after award of contract and prior to issuance of notice to proceed.**

PROJECT: \_\_\_\_\_  
(Project Name)

TO: \_\_\_\_\_  
(Name of Prime Bidder/Architect)

The undersigned intends to perform work in connection with the above project as a:

\_\_\_ Minority Business Enterprise                      \_\_\_ Women Business Enterprise

The M/WBE status of the undersigned is certified the NC Office of Historically Underutilized Businesses (required). \_\_\_ Yes \_\_\_ No

The undersigned is prepared to perform the following described work or provide materials or services in connection with the above project at the following dollar amount:

| Work/Materials/Service Provided | Dollar Amount of Contract | Projected Start Date | Projected End Date |
|---------------------------------|---------------------------|----------------------|--------------------|
|                                 |                           |                      |                    |
|                                 |                           |                      |                    |

\_\_\_\_\_  
(Date)

\_\_\_\_\_  
(Address)

\_\_\_\_\_  
(Name & Phone No. of M/WBE Firm)

\_\_\_\_\_  
(Name & Title of Authorized Representative of M/WBE)

\_\_\_\_\_  
(Signature of Authorized Representative of M/WBE)



## REQUEST TO CHANGE M/WBE PARTICIPATION

(Submit changes only if notified as apparent lowest bidder, continuing through project completion)

**Project:** \_\_\_\_\_

**Bidder or Prime Contractor:** \_\_\_\_\_

**Name & Title of Authorized Representative:** \_\_\_\_\_

**Address:** \_\_\_\_\_ **Phone #:** \_\_\_\_\_

\_\_\_\_\_ **Email Address:** \_\_\_\_\_

**Total Contract Amount (including approved change orders or amendments):** \$ \_\_\_\_\_

Name of subcontractor: \_\_\_\_\_

Good or service provided: \_\_\_\_\_

### Proposed Action:

Replace subcontractor

Perform work with own forces

For the above actions, you must provide one of the following reasons (Please check applicable reason):

The listed MBE/WBE, after having had a reasonable opportunity to do so, fails or refuses to execute a written contract.

The listed MBE/WBE is bankrupt or insolvent.

The listed MBE/WBE fails or refuses to perform his/her subcontract or furnish the listed materials.

The work performed by the listed subcontractor is unsatisfactory according to industry standards and is not in accordance with the plans and specifications; or the subcontractor is substantially delaying or disrupting the progress of the work.

*If replacing subcontractor:*

Name of replacement subcontractor: \_\_\_\_\_

The M/WBE status of the contractor is certified by the NC Office of Historically Underutilized Businesses (required).  Yes  No

Dollar amount of original contract \$ \_\_\_\_\_

Dollar amount of amended contract \$ \_\_\_\_\_

**Other Proposed Action:**

Increase total dollar amount of work

Add additional subcontractor

Decrease total dollar amount of work

Other

Please describe reason for requested action: \_\_\_\_\_

*If adding\* additional subcontractor:*

The M/WBE status of the contractor is certified by the NC Office of Historically Underutilized Businesses (required).  Yes  No

*\*Please attach Letter of Intent or executed contract document*

Dollar amount of original contract \$ \_\_\_\_\_

Dollar amount of amended contract \$ \_\_\_\_\_

**Interoffice Use Only:**

Approval  Y  N

Date \_\_\_\_\_

Signature \_\_\_\_\_

|   |
|---|
| Pay Application No. _____<br>Purchase Order No. _____ |
|---|

## Proof of Payment Certification

### M/WBE Contractors, Suppliers, Service Providers

Project Name: \_\_\_\_\_

Prime Contractor: \_\_\_\_\_

Current Contract Amount (including change orders): \$ \_\_\_\_\_

Requested Payment Amount for this Period: \$ \_\_\_\_\_

Is this the final payment? \_\_\_ Yes \_\_\_ No

| Firm Name | M/WBE Category* | Total Amount Paid from this Pay Request | Total Contract Amount (including changes) | Total Amount Remaining |
|-----------|-----------------|---|---|------------------------|
|           |                 |   |   |                        |
|           |                 |   |   |                        |
|           |                 |   |   |                        |
|           |                 |   |   |                        |

\*Minority categories: Black, African American (B), Hispanic or Latino (L), Asian American (A) American Indian (I), Female (F) Socially and Economically Disadvantaged (S) Disabled (D)

Date: \_\_\_\_\_

Certified By: \_\_\_\_\_

Name \_\_\_\_\_

Title \_\_\_\_\_

Signature \_\_\_\_\_





**E-VERIFY LETTER OF COMPLIANCE**

1. I have submitted a proposal for contract or desire to enter into a contract with the Greenville Utilities Commission;
2. As part of my duties and responsibilities pursuant to said proposal and/or contract, I affirm that I am aware of and in compliance with the requirements of E-Verify, Article 2 of Chapter 64 of the North Carolina General Statutes, to include (mark which applies):
  
3. \_\_\_\_ After hiring an employee to work in the United States I verify the work authorization of said employee through E-Verify and retain the record of the verification of work authorization while the employee is employed and for one year thereafter; or
4. \_\_\_\_ I employ less than fifteen (15) employees in the State of North Carolina.
  
5. As part of my duties and responsibilities pursuant to said proposal and/or contract, I affirm that to the best of my knowledge and subcontractors employed as a part of this proposal and/or contract, are in compliance with the requirements of E-Verify, Article 2 of Chapter 64 of the North Carolina General Statutes, to include (mark which applies):
  
6. \_\_\_\_ After hiring an employee to work in the United States the subcontractor verifies the work authorization of said employee through E-Verify and retains the record of the verification of work authorization while the employee is employed and for one year thereafter; or
  
7. \_\_\_\_ Employ less than fifteen (15) employees in the State of North Carolina.  
Specify subcontractor: \_\_\_\_\_

\_\_\_\_\_ (Company Name)

By: \_\_\_\_\_ (Typed Name)

\_\_\_\_\_ (Authorized Signatory)

\_\_\_\_\_ (Title)

\_\_\_\_\_ (Date)



## Notice of Award

Date: \_\_\_\_\_

Project: Northside Commercial Center – Sanitary Sewer Improvements

Owner: Greenville Utilities Commission

Owner's Contract No.:

Contract: Sanitary Sewer Improvements

Engineer's Project No.:

Bidder:.

Bidder's Address: *[send Notice of Award Certified Mail, Return Receipt Requested]*

You are notified that your Bid dated \_\_\_\_\_ for the above Contract has been considered. You are the Successful Bidder and are awarded a Contract for Northside Commercial Center - Sanitary Sewer Extension.

The Contract Price of your Contract is \$ \_\_\_\_\_.

Three (3) copies of the proposed Contract Documents (except Drawings) accompany this Notice of Award.

Three (3) sets of the Drawings will be delivered separately or otherwise made available to you immediately.

You must comply with the following conditions precedent within [15] days of the date you receive this Notice of Award.

1. Deliver to the Owner Three (3) fully executed counterparts of the Contract Documents.
2. Deliver with the executed Contract Documents the Contract security [Bonds] as specified in the Instructions to Bidders (Article 20), General Conditions (Paragraph 5.01), and Supplementary Conditions (Paragraph SC-5.01).
3. Other conditions precedent: None

Failure to comply with these conditions within the time specified will entitle Owner to consider you in default, annul this Notice of Award, and declare your Bid security forfeited.

Within ten days after you comply with the above conditions, Owner will return to you one fully executed counterpart of the Contract Documents.

\_\_\_\_\_  
Greenville Utilities Commission

Owner

By: \_\_\_\_\_

Authorized Signature

\_\_\_\_\_  
Title

Copy to Engineer



## AGREEMENT

THIS AGREEMENT is by and between GREENVILLE UTILITIES COMMISSION (“Owner”) and \_\_\_\_\_ (“Contractor”).

Owner and Contractor hereby agree as follows:

### ARTICLE 1 – WORK

1.01 Contractor shall complete all Work as specified or indicated in the Contract Documents. The Work is generally described as follows:

Construction of Gravity Sanitary Sewer Main, Manholes and services in Northside Commercial Center.

### ARTICLE 2 – THE PROJECT

2.01 The Project for which the Work under the Contract Documents may be the whole or only a part is generally described as follows:

**NORTHSIDE COMMERCIAL CENTER  
SANITARY SEWER EXTENSION**

### ARTICLE 3 – ENGINEER

3.01 The Project has been designed by Ark Consulting Group, PLLC (Engineer), which is to act as Owner’s representative, assume all duties and responsibilities, and have the rights and authority assigned to Engineer in the Contract Documents in connection with the completion of the Work in accordance with the Contract Documents.

3.02 Once the Notice of Award has been issued, the Owner may assume all or part of the responsibilities of the Engineer and Resident Project Representative.

### ARTICLE 4 – CONTRACT TIMES

4.01 *Time of the Essence*

A. All time limits for Milestones, if any, and completion and readiness for final payment as stated in the Contract Documents are of the essence of the Contract.

#### 4.02 *Days to Achieve Completion and Final Payment*

- A. The Work will be completed and ready for final payment in accordance with Paragraph 14.07 of the General Conditions within 90 days after the date when the Contract Times commence to run as provided in Paragraph 2.03 of the General Conditions.

#### 4.03 *Liquidated Damages*

- A. Contractor and Owner recognize that time is of the essence as stated in Paragraph 4.01 above and that Owner will suffer financial loss if the Work is not completed within the times specified in Paragraph 4.02 above, plus any extensions thereof allowed in accordance with Article 12 of the General Conditions. The parties also recognize the delays, expense, and difficulties involved in proving in a legal or arbitration proceeding the actual loss suffered by Owner if the Work is not completed on time. Accordingly, instead of requiring any such proof, Owner and Contractor agree that as liquidated damages for delay (but not as a penalty), Contractor shall pay Owner \$500.00 for each day that expires after the time specified in Paragraph 4.02 above for completion and readiness for final payment until the Work is completed and ready for final payment.

### **ARTICLE 5 – CONTRACT PRICE**

- 5.01 Owner shall pay Contractor for completion of the Work in accordance with the Contract Documents an amount in current funds equal to the sum of the amounts determined pursuant to Paragraph 5.01.A below:

- A. For all Work, at the prices stated in Contractor's Bid, attached hereto as an exhibit.

### **ARTICLE 6 – PAYMENT PROCEDURES**

#### 6.01 *Submittal and Processing of Payments*

- A. Contractor shall submit Applications for Payment in accordance with Article 14 of the General Conditions. Applications for Payment will be processed by Engineer as provided in the General Conditions.

#### 6.02 *Progress Payments; Retainage*

- A. Owner shall make progress payments on account of the Contract Price on the basis of Contractor's Applications for Payment on or about the 25th day of each month during performance of the Work as provided in Paragraphs 6.02.A.1 and 6.02.A.2 below. All such payments will be measured by the schedule of values established as provided in Paragraph 2.07.A of the General Conditions (and in the case of Unit Price Work based on

the number of units completed) or, in the event there is no schedule of values, as provided in the General Requirements.

1. Prior to Final Completion, progress payments will be made in an amount equal to the percentage indicated below but, in each case, less the aggregate of payments previously made and less such amounts as Engineer may determine or Owner may withhold, including but not limited to liquidated damages, in accordance with Paragraph 14.02 of the General Conditions.
  - a. 95% of Work completed (with the balance being retainage). If the Work has been 50% completed as determined by ENGINEER, and if the character and progress of the Work have been satisfactory to OWNER and ENGINEER, and CONTRACTOR has provided written consent of surety, OWNER, on recommendation of ENGINEER, may determine that as long as the character and progress of the Work remain satisfactory to them, there will be no retainage on account of Work subsequently completed. The 50% of work completed shall be based on CONTRACTOR's pay request with off-site materials excluded and a maximum of 20% of on-site stored materials included.
  - b. 95% of cost of materials and equipment not incorporated in the Work (with the balance being retainage) but delivered and suitably stored in a location and manner agreed to in writing and pursuant to paragraph 14.02.A.1 of the General Conditions.
- B. Upon Final Completion, Owner shall pay an amount sufficient to increase total payments to Contractor to **100** percent of the Work completed, less such amounts as Engineer shall determine in accordance with Paragraph 14.02.B.5 of the General Conditions and less **200** percent of Engineer's estimate of the value of Work to be completed or corrected as shown on the tentative list of items to be completed or corrected attached to the certificate of Substantial Completion.

### 6.03 *Final Payment*

- A. Upon final completion and acceptance of the Work in accordance with Paragraph 14.07 of the General Conditions, Owner shall pay the remainder of the Contract Price as recommended by Engineer as provided in said Paragraph 14.07, **less any sum Owner is entitled to set off against Engineer's recommendation, including but not limited to liquidated damages.**

**ARTICLE 7 – INTEREST**

7.01 All moneys not paid when due as provided in Article 14 of the General Conditions shall bear interest at the maximum legal rate.

**ARTICLE 8 – CONTRACTOR’S REPRESENTATIONS**

8.01 In order to induce Owner to enter into this Agreement, Contractor makes the following representations:

- A. Contractor has examined and carefully studied the Contract Documents and the other related data identified in the Bidding Documents.
- B. Contractor has visited the Site and become familiar with and is satisfied as to the general, local, and Site conditions that may affect cost, progress, and performance of the Work.
- C. Contractor is familiar with and is satisfied as to all federal, state, and local Laws and Regulations that may affect cost, progress, and performance of the Work.
- D. Contractor has carefully studied all: (1) reports of explorations and tests of subsurface conditions at or contiguous to the Site and all drawings of physical conditions relating to existing surface or subsurface structures at the Site (except Underground Facilities), if any, that have been identified in Paragraph SC-4.02 of the Supplementary Conditions as containing reliable "technical data," and (2) reports and drawings of Hazardous Environmental Conditions, if any, at the Site that have been identified in Paragraph SC-4.06 of the Supplementary Conditions as containing reliable "technical data."
- E. Contractor has considered the information known to Contractor; information commonly known to contractors doing business in the locality of the Site; information and observations obtained from visits to the Site; the Contract Documents; and the Site-related reports and drawings identified in the Contract Documents, with respect to the effect of such information, observations, and documents on (1) the cost, progress, and performance of the Work; (2) the means, methods, techniques, sequences, and procedures of construction to be employed by Contractor, including any specific means, methods, techniques, sequences, and procedures of construction expressly required by the Contract Documents; and (3) Contractor’s safety precautions and programs.
- F. Based on the information and observations referred to in Paragraph 8.01.E above, Contractor does not consider that further examinations, investigations, explorations, tests, studies, or data are necessary for the performance of the Work at the Contract Price, within the Contract Times, and in accordance with the other terms and conditions of the Contract Documents.



- G. Contractor is aware of the general nature of work to be performed by Owner and others at the Site that relates to the Work as indicated in the Contract Documents.
- H. Contractor has given Engineer written notice of all conflicts, errors, ambiguities, or discrepancies that Contractor has discovered in the Contract Documents, and the written resolution thereof by Engineer is acceptable to Contractor.
- I. The Contract Documents are generally sufficient to indicate and convey understanding of all terms and conditions for performance and furnishing of the Work.
- J. **Contractor has correlated the information known to Contractor, information and observations obtained from visits to the Site, reports and drawings identified in the Contract Documents, and all additional examinations, investigations, explorations, tests, studies, and data with the Contract Documents.**

## ARTICLE 9 – CONTRACT DOCUMENTS

### 9.01 *Contents*

- A. The Contract Documents consist of the following:
  - 1. This Agreement (pages 1 to 8, inclusive).
  - 2. General Conditions (pages 1 to 65, inclusive).
  - 3. Supplementary Conditions (pages 1 to 7, inclusive).
  - 4. Specifications as listed in the table of contents of the Project Manual.
  - 5. Drawings consisting of 5 sheets with each sheet bearing the following general title: Northside Commercial Center – Sanitary Sewer Extension Ark Consulting Group, PLLC Drawing No. D-1244.
  - 6. Addenda (numbers \_\_\_ to \_\_\_\_, inclusive).
  - 7. Exhibits to this Agreement (enumerated as follows):
    - a. Contractor’s Bid (pages 1 to 8, inclusive).
    - b. E-Verify Letter of Compliance (page E-1).
    - b. Documentation submitted by Contractor prior to Notice of Award (pages \_\_\_ to \_\_\_\_, inclusive).
  - 8. Payment and Performance Bonds.

9. Certificate of Insurance.
10. The following which may be delivered or issued on or after the Effective Date of the Agreement and are not attached hereto:
  - a. Notice to Proceed (pages NP-1 to NP-1, inclusive).
  - b. Work Change Directives.
  - c. Change Orders.
- B. The documents listed in Paragraph 9.01.A are attached to this Agreement (except as expressly noted otherwise above).
- C. There are no Contract Documents other than those listed above in this Article 9.
- D. The Contract Documents may only be amended, modified, or supplemented as provided in Paragraph 3.04 of the General Conditions.

## **ARTICLE 10 – MISCELLANEOUS**

### 10.01 *Terms*

- A. Terms used in this Agreement will have the meanings stated in the General Conditions and the Supplementary Conditions.

### 10.02 *Assignment of Contract*

- A. No assignment by a party hereto of any rights under or interests in the Contract will be binding on another party hereto without the written consent of the party sought to be bound; and, specifically but without limitation, moneys that may become due and moneys that are due may not be assigned without such consent (except to the extent that the effect of this restriction may be limited by law), and unless specifically stated to the contrary in any written consent to an assignment, no assignment will release or discharge the assignor from any duty or responsibility under the Contract Documents.

### 10.03 *Successors and Assigns*

- A. Owner and Contractor each binds itself, its partners, successors, assigns, and legal representatives to the other party hereto, its partners, successors, assigns, and legal representatives in respect to all covenants, agreements, and obligations contained in the Contract Documents.

#### 10.04 *Severability*

- A. Any provision or part of the Contract Documents held to be void or unenforceable under any Law or Regulation shall be deemed stricken, and all remaining provisions shall continue to be valid and binding upon Owner and Contractor, who agree that the Contract Documents shall be reformed to replace such stricken provision or part thereof with a valid and enforceable provision that comes as close as possible to expressing the intention of the stricken provision.

#### 10.05 *Contractor's Certifications*

- A. Contractor certifies that it has not engaged in corrupt, fraudulent, collusive, or coercive practices in competing for or in executing the Contract. For the purposes of this Paragraph 10.05:
  - 1. "corrupt practice" means the offering, giving, receiving, or soliciting of any thing of value likely to influence the action of a public official in the bidding process or in the Contract execution;
  - 2. "fraudulent practice" means an intentional misrepresentation of facts made (a) to influence the bidding process or the execution of the Contract to the detriment of Owner, (b) to establish Bid or Contract prices at artificial non-competitive levels, or (c) to deprive Owner of the benefits of free and open competition;
  - 3. "collusive practice" means a scheme or arrangement between two or more Bidders, with or without the knowledge of Owner, a purpose of which is to establish Bid prices at artificial, non-competitive levels; and
  - 4. "coercive practice" means harming or threatening to harm, directly or indirectly, persons or their property to influence their participation in the bidding process or affect the execution of the Contract.

IN WITNESS WHEREOF, Owner and Contractor have signed this Agreement. Counterparts have been delivered to Owner and Contractor. All portions of the Contract Documents have been signed or have been identified by Owner and Contractor or on their behalf.

This Agreement will be effective on \_\_\_\_\_(which is the Effective Date of the Agreement).

OWNER:

CONTRACTOR:

\_\_\_\_\_ Greenville Utilities Commission

\_\_\_\_\_

By: \_\_\_\_\_

By: \_\_\_\_\_

Title: \_\_\_\_\_

Title: \_\_\_\_\_

(If Contractor is a corporation, a partnership, or a joint venture, attach evidence of authority to sign.)

Attest: \_\_\_\_\_

Attest: \_\_\_\_\_

Title: \_\_\_\_\_

Title: \_\_\_\_\_

Address for giving notices:

Address for giving notices:

\_\_\_\_\_  
\_\_\_\_\_  
\_\_\_\_\_

\_\_\_\_\_  
\_\_\_\_\_  
\_\_\_\_\_

License No.: \_\_\_\_\_

(Where applicable)

(If Owner is a corporation, attach evidence of authority to sign. If Owner is a public body, attach evidence of authority to sign and resolution or other documents authorizing execution of this Agreement.)

Agent for service of process:

\_\_\_\_\_

# Notice to Proceed

Date:

Project: Northside Commercial Center Sanitary Sewer Extension

Owner: Greenville Utilities Commission

Owner's Contract No.:

Contract: Sanitary Sewer Improvements

Engineer's Project No.: 20049

Contractor:

Contractor's Address: *[send Certified Mail, Return Receipt Requested]*

You are notified that the Contract Times under the above Contract will commence to run on \_\_\_\_\_. On or before that date, you are to start performing your obligations under the Contract Documents. In accordance with Article 4 of the Agreement, the date of Final Completion is \_\_\_\_\_.

Before you may start any Work at the Site, you and Owner must each deliver to the other (with copies to Engineer and other identified additional insureds and loss payees) certificates of insurance which each is required to purchase and maintain in accordance with the Contract Documents.

Also, before you may start any Work at the Site, you must:

*Schedule and attend a Pre-Construction Conference with the Owner and Engineer.*

|       |                                 |
|-------|---------------------------------|
| _____ | Greenville Utilities Commission |
| _____ | Owner                           |
| _____ | Given by:                       |
| _____ | Authorized Signature            |
| _____ | Title                           |
| _____ | Date                            |

Copy to Engineer





### PERFORMANCE BOND

CONTRACTOR *(name and address):*

SURETY *(name and address of principal place of business):*

OWNER *(name and address):*

#### CONSTRUCTION CONTRACT

Effective Date of the Agreement:  
Amount:  
Description *(name and location):*

#### BOND

Bond Number:  
Date *(not earlier than the Effective Date of the Agreement of the Construction Contract):*  
Amount:  
Modifications to this Bond Form:  None  See Paragraph 16

Surety and Contractor, intending to be legally bound hereby, subject to the terms set forth below, do each cause this Performance Bond to be duly executed by an authorized officer, agent, or representative.

#### CONTRACTOR AS PRINCIPAL

#### SURETY

\_\_\_\_\_  
*(seal)*  
Contractor's Name and Corporate Seal

\_\_\_\_\_  
*(seal)*  
Surety's Name and Corporate Seal

By: \_\_\_\_\_  
Signature

By: \_\_\_\_\_  
Signature *(attach power of attorney)*

\_\_\_\_\_  
Print Name

\_\_\_\_\_  
Print Name

\_\_\_\_\_  
Title

\_\_\_\_\_  
Title

Attest: \_\_\_\_\_  
Signature

Attest: \_\_\_\_\_  
Signature

\_\_\_\_\_  
Title

\_\_\_\_\_  
Title

**Notes: (1) Provide supplemental execution by any additional parties, such as joint venturers. (2) Any singular reference to Contractor, Surety, Owner, or other party shall be considered plural where applicable.**

1. The Contractor and Surety, jointly and severally, bind themselves, their heirs, executors, administrators, successors, and assigns to the Owner for the performance of the Construction Contract, which is incorporated herein by reference.

2. If the Contractor performs the Construction Contract, the Surety and the Contractor shall have no obligation under this Bond, except when applicable to participate in a conference as provided in Paragraph 3.

3. If there is no Owner Default under the Construction Contract, the Surety's obligation under this Bond shall arise after:

3.1 The Owner first provides notice to the Contractor and the Surety that the Owner is considering declaring a Contractor Default. Such notice shall indicate whether the Owner is requesting a conference among the Owner, Contractor, and Surety to discuss the Contractor's performance. If the Owner does not request a conference, the Surety may, within five (5) business days after receipt of the Owner's notice, request such a conference. If the Surety timely requests a conference, the Owner shall attend. Unless the Owner agrees otherwise, any conference requested under this Paragraph 3.1 shall be held within ten (10) business days of the Surety's receipt of the Owner's notice. If the Owner, the Contractor, and the Surety agree, the Contractor shall be allowed a reasonable time to perform the Construction Contract, but such an agreement shall not waive the Owner's right, if any, subsequently to declare a Contractor Default;

3.2 The Owner declares a Contractor Default, terminates the Construction Contract and notifies the Surety; and

3.3 The Owner has agreed to pay the Balance of the Contract Price in accordance with the terms of the Construction Contract to the Surety or to a contractor selected to perform the Construction Contract.

4. Failure on the part of the Owner to comply with the notice requirement in Paragraph 3.1 shall not constitute a failure to comply with a condition precedent to the Surety's obligations, or release the Surety from its obligations, except to the extent the Surety demonstrates actual prejudice.

5. When the Owner has satisfied the conditions of Paragraph 3, the Surety shall promptly and at the Surety's expense take one of the following actions:

5.1 Arrange for the Contractor, with the consent of the Owner, to perform and complete the Construction Contract;

5.2 Undertake to perform and complete the Construction Contract itself, through its agents or independent contractors;

5.3 Obtain bids or negotiated proposals from qualified contractors acceptable to the Owner for a contract for performance and completion of the Construction Contract, arrange for a contract to be prepared for execution by the Owner and a contractor selected with the Owners concurrence, to be secured with performance and payment bonds executed by a qualified surety equivalent to the bonds issued on the Construction Contract, and pay to the Owner the amount of damages as described in Paragraph 7 in excess of the Balance of

the Contract Price incurred by the Owner as a result of the Contractor Default; or

5.4 Waive its right to perform and complete, arrange for completion, or obtain a new contractor, and with reasonable promptness under the circumstances:

5.4.1 After investigation, determine the amount for which it may be liable to the Owner and, as soon as practicable after the amount is determined, make payment to the Owner; or

5.4.2 Deny liability in whole or in part and notify the Owner, citing the reasons for denial.

6. If the Surety does not proceed as provided in Paragraph 5 with reasonable promptness, the Surety shall be deemed to be in default on this Bond seven days after receipt of an additional written notice from the Owner to the Surety demanding that the Surety perform its obligations under this Bond, and the Owner shall be entitled to enforce any remedy available to the Owner. If the Surety proceeds as provided in Paragraph 5.4, and the Owner refuses the payment or the Surety has denied liability, in whole or in part, without further notice the Owner shall be entitled to enforce any remedy available to the Owner.

7. If the Surety elects to act under Paragraph 5.1, 5.2, or 5.3, then the responsibilities of the Surety to the Owner shall not be greater than those of the Contractor under the Construction Contract, and the responsibilities of the Owner to the Surety shall not be greater than those of the Owner under the Construction Contract. Subject to the commitment by the Owner to pay the Balance of the Contract Price, the Surety is obligated, without duplication for:

7.1 the responsibilities of the Contractor for correction of defective work and completion of the Construction Contract;

7.2 additional legal, design professional, and delay costs resulting from the Contractor's Default, and resulting from the actions or failure to act of the Surety under Paragraph 5; and

7.3 liquidated damages, or if no liquidated damages are specified in the Construction Contract, actual damages caused by delayed performance or non-performance of the Contractor.

8. If the Surety elects to act under Paragraph 5.1, 5.3, or 5.4, the Surety's liability is limited to the amount of this Bond.

9. The Surety shall not be liable to the Owner or others for obligations of the Contractor that are unrelated to the Construction Contract, and the Balance of the Contract Price shall not be reduced or set off on account of any such unrelated obligations. No right of action shall accrue on this Bond to any person or entity other than the Owner or its heirs, executors, administrators, successors, and assigns.

10. The Surety hereby waives notice of any change, including changes of time, to the Construction Contract or to related subcontracts, purchase orders, and other obligations.

11. Any proceeding, legal or equitable, under this Bond may be instituted in any court of competent jurisdiction in the location in which the work or part of the work is located and shall be instituted within two years after a declaration of Contractor Default or within



two years after the Contractor ceased working or within two years after the Surety refuses or fails to perform its obligations under this Bond, whichever occurs first. If the provisions of this paragraph are void or prohibited by law, the minimum periods of limitations available to sureties as a defense in the jurisdiction of the suit shall be applicable.

12. Notice to the Surety, the Owner, or the Contractor shall be mailed or delivered to the address shown on the page on which their signature appears.

13. When this Bond has been furnished to comply with a statutory or other legal requirement in the location where the construction was to be performed, any provision in this Bond conflicting with said statutory or legal requirement shall be deemed deleted herefrom and provisions conforming to such statutory or other legal requirement shall be deemed incorporated herein. When so furnished, the intent is that this Bond shall be construed as a statutory bond and not as a common law bond.

#### 14. Definitions

14.1 Balance of the Contract Price: The total amount payable by the Owner to the Contractor under the Construction Contract after all proper adjustments have been made including allowance for the Contractor for any amounts received or to be received by the Owner in settlement of insurance or other claims for damages to which the Contractor is entitled, reduced by all valid and proper payments made to or on behalf of the Contractor under the Construction Contract.

14.2 Construction Contract: The agreement between the Owner and Contractor identified on the cover page, including all Contract Documents and changes made to the agreement and the Contract Documents.

14.3 Contractor Default: Failure of the Contractor, which has not been remedied or waived, to perform or otherwise to comply with a material term of the Construction Contract.

14.4 Owner Default: Failure of the Owner, which has not been remedied or waived, to pay the Contractor as required under the Construction Contract or to perform and complete or comply with the other material terms of the Construction Contract.

14.5 Contract Documents: All the documents that comprise the agreement between the Owner and Contractor.

15. If this Bond is issued for an agreement between a contractor and subcontractor, the term Contractor in this Bond shall be deemed to be Subcontractor and the term Owner shall be deemed to be Contractor.

16. Modifications to this Bond are as follows:





### PAYMENT BOND

CONTRACTOR *(name and address):*

SURETY *(name and address of principal place of business):*

OWNER *(name and address):*

#### CONSTRUCTION CONTRACT

Effective Date of the Agreement:

Amount:

Description *(name and location):*

#### BOND

Bond Number:

Date *(not earlier than the Effective Date of the Agreement of the Construction Contract):*

Amount:

Modifications to this Bond Form:  None  See Paragraph 18

Surety and Contractor, intending to be legally bound hereby, subject to the terms set forth below, do each cause this Payment Bond to be duly executed by an authorized officer, agent, or representative.

#### CONTRACTOR AS PRINCIPAL

#### SURETY

\_\_\_\_\_  
Contractor's Name and Corporate Seal *(seal)*

\_\_\_\_\_  
Surety's Name and Corporate Seal *(seal)*

By: \_\_\_\_\_  
Signature

By: \_\_\_\_\_  
Signature *(attach power of attorney)*

\_\_\_\_\_  
Print Name

\_\_\_\_\_  
Print Name

\_\_\_\_\_  
Title

\_\_\_\_\_  
Title

Attest: \_\_\_\_\_  
Signature

Attest: \_\_\_\_\_  
Signature

\_\_\_\_\_  
Title

\_\_\_\_\_  
Title

**Notes: (1) Provide supplemental execution by any additional parties, such as joint venturers. (2) Any singular reference to Contractor, Surety, Owner, or other party shall be considered plural where applicable.**

1. The Contractor and Surety, jointly and severally, bind themselves, their heirs, executors, administrators, successors, and assigns to the Owner to pay for labor, materials, and equipment furnished for use in the performance of the Construction Contract, which is incorporated herein by reference, subject to the following terms.
2. If the Contractor promptly makes payment of all sums due to Claimants, and defends, indemnifies, and holds harmless the Owner from claims, demands, liens, or suits by any person or entity seeking payment for labor, materials, or equipment furnished for use in the performance of the Construction Contract, then the Surety and the Contractor shall have no obligation under this Bond.
3. If there is no Owner Default under the Construction Contract, the Surety's obligation to the Owner under this Bond shall arise after the Owner has promptly notified the Contractor and the Surety (at the address described in Paragraph 13) of claims, demands, liens, or suits against the Owner or the Owner's property by any person or entity seeking payment for labor, materials, or equipment furnished for use in the performance of the Construction Contract, and tendered defense of such claims, demands, liens, or suits to the Contractor and the Surety.
4. When the Owner has satisfied the conditions in Paragraph 3, the Surety shall promptly and at the Surety's expense defend, indemnify, and hold harmless the Owner against a duly tendered claim, demand, lien, or suit.
5. The Surety's obligations to a Claimant under this Bond shall arise after the following:
  - 5.1 Claimants who do not have a direct contract with the Contractor,
    - 5.1.1 have furnished a written notice of non-payment to the Contractor, stating with substantial accuracy the amount claimed and the name of the party to whom the materials were, or equipment was, furnished or supplied or for whom the labor was done or performed, within ninety (90) days after having last performed labor or last furnished materials or equipment included in the Claim; and
    - 5.1.2 have sent a Claim to the Surety (at the address described in Paragraph 13).
  - 5.2 Claimants who are employed by or have a direct contract with the Contractor have sent a Claim to the Surety (at the address described in Paragraph 13).
6. If a notice of non-payment required by Paragraph 5.1.1 is given by the Owner to the Contractor, that is sufficient to satisfy a Claimant's obligation to furnish a written notice of non-payment under Paragraph 5.1.1.
7. When a Claimant has satisfied the conditions of Paragraph 5.1 or 5.2, whichever is applicable, the Surety shall promptly and at the Surety's expense take the following actions:
  - 7.1 Send an answer to the Claimant, with a copy to the Owner, within sixty (60) days after receipt of the Claim, stating the amounts that are undisputed and the basis for challenging any amounts that are disputed; and
  - 7.2 Pay or arrange for payment of any undisputed amounts.
  - 7.3 The Surety's failure to discharge its obligations under Paragraph 7.1 or 7.2 shall not be deemed to constitute a waiver of defenses the Surety or Contractor may have or acquire as to a Claim, except as to undisputed amounts for which the Surety and Claimant have reached agreement. If, however, the Surety fails to discharge its obligations under Paragraph 7.1 or 7.2, the Surety shall indemnify the Claimant for the reasonable attorney's fees the Claimant incurs thereafter to recover any sums found to be due and owing to the Claimant.
8. The Surety's total obligation shall not exceed the amount of this Bond, plus the amount of reasonable attorney's fees provided under Paragraph 7.3, and the amount of this Bond shall be credited for any payments made in good faith by the Surety.
9. Amounts owed by the Owner to the Contractor under the Construction Contract shall be used for the performance of the Construction Contract and to satisfy claims, if any, under any construction performance bond. By the Contractor furnishing and the Owner accepting this Bond, they agree that all funds earned by the Contractor in the performance of the Construction Contract are dedicated to satisfy obligations of the Contractor and Surety under this Bond, subject to the Owner's priority to use the funds for the completion of the work.
10. The Surety shall not be liable to the Owner, Claimants, or others for obligations of the Contractor that are unrelated to the Construction Contract. The Owner shall not be liable for the payment of any costs or expenses of any Claimant under this Bond, and shall have under this Bond no obligation to make payments to or give notice on behalf of Claimants, or otherwise have any obligations to Claimants under this Bond.
11. The Surety hereby waives notice of any change, including changes of time, to the Construction Contract or to related subcontracts, purchase orders, and other obligations.
12. No suit or action shall be commenced by a Claimant under this Bond other than in a court of competent jurisdiction in the state in which the project that is the subject of the Construction Contract is located or after the expiration of one year from the date (1) on which the Claimant sent a

Claim to the Surety pursuant to Paragraph 5.1.2 or 5.2, or (2) on which the last labor or service was performed by anyone or the last materials or equipment were furnished by anyone under the Construction Contract, whichever of (1) or (2) first occurs. If the provisions of this paragraph are void or prohibited by law, the minimum period of limitation available to sureties as a defense in the jurisdiction of the suit shall be applicable.

13. Notice and Claims to the Surety, the Owner, or the Contractor shall be mailed or delivered to the address shown on the page on which their signature appears. Actual receipt of notice or Claims, however accomplished, shall be sufficient compliance as of the date received.
14. When this Bond has been furnished to comply with a statutory or other legal requirement in the location where the construction was to be performed, any provision in this Bond conflicting with said statutory or legal requirement shall be deemed deleted herefrom and provisions conforming to such statutory or other legal requirement shall be deemed incorporated herein. When so furnished, the intent is that this Bond shall be construed as a statutory bond and not as a common law bond.
15. Upon requests by any person or entity appearing to be a potential beneficiary of this Bond, the Contractor and Owner shall promptly furnish a copy of this Bond or shall permit a copy to be made.

#### 16. Definitions

16.1 **Claim:** A written statement by the Claimant including at a minimum:

1. The name of the Claimant;
2. The name of the person for whom the labor was done, or materials or equipment furnished;
3. A copy of the agreement or purchase order pursuant to which labor, materials, or equipment was furnished for use in the performance of the Construction Contract;
4. A brief description of the labor, materials, or equipment furnished;
5. The date on which the Claimant last performed labor or last furnished materials or equipment for use in the performance of the Construction Contract;
6. The total amount earned by the Claimant for labor, materials, or equipment furnished as of the date of the Claim;
7. The total amount of previous payments received by the Claimant; and
8. The total amount due and unpaid to the Claimant for labor, materials, or equipment furnished as of the date of the Claim.

16.2 **Claimant:** An individual or entity having a direct contract with the Contractor or with a subcontractor of the Contractor to furnish labor, materials, or equipment for use in the performance of the Construction Contract. The term Claimant also includes any individual or entity that has rightfully asserted a claim under an applicable mechanic's

lien or similar statute against the real property upon which the Project is located. The intent of this Bond shall be to include without limitation in the terms of "labor, materials, or equipment" that part of the water, gas, power, light, heat, oil, gasoline, telephone service, or rental equipment used in the Construction Contract, architectural and engineering services required for performance of the work of the Contractor and the Contractor's subcontractors, and all other items for which a mechanic's lien may be asserted in the jurisdiction where the labor, materials, or equipment were furnished.

16.3 **Construction Contract:** The agreement between the Owner and Contractor identified on the cover page, including all Contract Documents and all changes made to the agreement and the Contract Documents.

16.4 **Owner Default:** Failure of the Owner, which has not been remedied or waived, to pay the Contractor as required under the Construction Contract or to perform and complete or comply with the other material terms of the Construction Contract.

16.5 **Contract Documents:** All the documents that comprise the agreement between the Owner and Contractor.

17. If this Bond is issued for an agreement between a contractor and subcontractor, the term Contractor in this Bond shall be deemed to be Subcontractor and the term Owner shall be deemed to be Contractor.

18. Modifications to this Bond are as follows:





# CERTIFICATE OF LIABILITY INSURANCE

DATE (MM/DD/YYYY)

| <b>PRODUCER</b><br>ABC Insurance Agency<br>Street<br>City, State, Zip | <b>THIS CERTIFICATE IS ISSUED AS A MATTER OF INFORMATION ONLY AND CONFERS NO RIGHTS UPON THE CERTIFICATE HOLDER. THIS CERTIFICATE DOES NOT AMEND, EXTEND OR ALTER THE COVERAGE AFFORDED BY THE POLICIES BELOW.</b>   |                             |        |                                 |  |                                 |  |                                 |  |                                 |  |            |  |
|---|--|-----------------------------|--------|---------------------------------|--|---------------------------------|--|---------------------------------|--|---------------------------------|--|------------|--|
| <b>INSURED</b><br>XYZ Contractor<br>Street<br>City, State, Zip        | <table border="1" style="width: 100%; border-collapse: collapse;"> <tr> <th style="width: 80%;">INSURERS AFFORDING COVERAGE</th> <th style="width: 20%;">NAIC #</th> </tr> <tr> <td>INSURER A: Name of Insurance Co</td> <td></td> </tr> <tr> <td>INSURER B: Name of Insurance Co</td> <td></td> </tr> <tr> <td>INSURER C: Name of Insurance Co</td> <td></td> </tr> <tr> <td>INSURER D: Name of Insurance Co</td> <td></td> </tr> <tr> <td>INSURER E:</td> <td></td> </tr> </table> | INSURERS AFFORDING COVERAGE | NAIC # | INSURER A: Name of Insurance Co |  | INSURER B: Name of Insurance Co |  | INSURER C: Name of Insurance Co |  | INSURER D: Name of Insurance Co |  | INSURER E: |  |
| INSURERS AFFORDING COVERAGE   | NAIC #   |                             |        |                                 |  |                                 |  |                                 |  |                                 |  |            |  |
| INSURER A: Name of Insurance Co                                       |  |                             |        |                                 |  |                                 |  |                                 |  |                                 |  |            |  |
| INSURER B: Name of Insurance Co                                       |  |                             |        |                                 |  |                                 |  |                                 |  |                                 |  |            |  |
| INSURER C: Name of Insurance Co                                       |  |                             |        |                                 |  |                                 |  |                                 |  |                                 |  |            |  |
| INSURER D: Name of Insurance Co                                       |  |                             |        |                                 |  |                                 |  |                                 |  |                                 |  |            |  |
| INSURER E:  |  |                             |        |                                 |  |                                 |  |                                 |  |                                 |  |            |  |

**COVERAGES**

THE POLICIES OF INSURANCE LISTED BELOW HAVE BEEN ISSUED TO THE INSURED NAMED ABOVE FOR THE POLICY PERIOD INDICATED. NOTWITHSTANDING ANY REQUIREMENT, TERM OR CONDITION OF ANY CONTRACT OR OTHER DOCUMENT WITH RESPECT TO WHICH THIS CERTIFICATE MAY BE ISSUED OR MAY PERTAIN, THE INSURANCE AFFORDED BY THE POLICIES DESCRIBED HEREIN IS SUBJECT TO ALL THE TERMS, EXCLUSIONS AND CONDITIONS OF SUCH POLICIES. AGGREGATE LIMITS SHOWN MAY HAVE BEEN REDUCED BY PAID CLAIMS.

| INSR LTR | ADD'L INSRD | TYPE OF INSURANCE  | POLICY NUMBER | POLICY EFFECTIVE DATE (MM/DD/YY) | POLICY EXPIRATION DATE (MM/DD/YY) | LIMITS  |
|----------|-------------|--|---------------|----------------------------------|-----------------------------------|---|
| A        | A           | <b>GENERAL LIABILITY</b><br><input checked="" type="checkbox"/> COMMERCIAL GENERAL LIABILITY<br><input type="checkbox"/> CLAIMS MADE <input checked="" type="checkbox"/> OCCUR<br><input checked="" type="checkbox"/> Explosion, Collapse Hazard<br><input checked="" type="checkbox"/> Underground Hazard<br>GEN'L AGGREGATE LIMIT APPLIES PER:<br><input type="checkbox"/> POLICY <input checked="" type="checkbox"/> PROJECT <input type="checkbox"/> LOC |               |                                  |                                   | EACH OCCURRENCE \$ 1,000,000<br>DAMAGE TO RENTED PREMISES (Ea occurrence) \$ 50,000<br>MED EXP (Any one person) \$ 5,000<br>PERSONAL & ADV INJURY \$ 1,000,000<br>GENERAL AGGREGATE \$ 2,000,000<br>PRODUCTS - COMP/OP AGG \$ 2,000,000 |
| B        |             | <b>AUTOMOBILE LIABILITY</b><br><input checked="" type="checkbox"/> ANY AUTO<br><input type="checkbox"/> ALL OWNED AUTOS<br><input type="checkbox"/> SCHEDULED AUTOS<br><input checked="" type="checkbox"/> HIRED AUTOS<br><input checked="" type="checkbox"/> NON-OWNED AUTOS  |               |                                  |                                   | COMBINED SINGLE LIMIT (Ea accident) \$ 1,000,000<br>BODILY INJURY (Per person) \$<br>BODILY INJURY (Per accident) \$<br>PROPERTY DAMAGE (Per accident) \$   |
|          |             | <b>GARAGE LIABILITY</b><br><input type="checkbox"/> ANY AUTO   |               |                                  |                                   | AUTO ONLY - EA ACCIDENT \$<br>OTHER THAN EA ACC \$<br>AUTO ONLY: AGG \$   |
| C        |             | <b>EXCESS/UMBRELLA LIABILITY</b><br><input checked="" type="checkbox"/> OCCUR <input type="checkbox"/> CLAIMS MADE<br>DEDUCTIBLE \$<br>RETENTION \$  |               |                                  |                                   | EACH OCCURRENCE \$ 5,000,000<br>AGGREGATE \$ 5,000,000<br>\$<br>\$<br>\$  |
| D        |             | <b>WORKERS COMPENSATION AND EMPLOYERS' LIABILITY</b><br>ANY PROPRIETOR/PARTNER/EXECUTIVE OFFICER/MEMBER EXCLUDED?<br>If yes, describe under SPECIAL PROVISIONS below   |               |                                  |                                   | <input checked="" type="checkbox"/> WC STATUTORY LIMITS <input type="checkbox"/> OTHER<br>E.L. EACH ACCIDENT \$ 500,000<br>E.L. DISEASE - EA EMPLOYEE \$ 500,000<br>E.L. DISEASE - POLICY LIMIT \$ 500,000                              |
|          |             | <b>OTHER</b>   |               |                                  |                                   |   |

**DESCRIPTION OF OPERATIONS / LOCATIONS / VEHICLES / EXCLUSIONS ADDED BY ENDORSEMENT / SPECIAL PROVISIONS**  
 Coverage applies to (Project Name and Contract No.). Certificate holder is named as Additional Insured, per attached ISO Form CG 20 10 11-85 or equivalent.  
 Waiver of Subrogation is added by endorsement.

|  |  |
|--|--|
| <b>CERTIFICATE HOLDER</b><br>Contractor/Owner/Engineer<br>Street<br>City, State, Zip | <b>CANCELLATION</b><br>SHOULD ANY OF THE ABOVE DESCRIBED POLICIES BE CANCELLED BEFORE THE EXPIRATION DATE THEREOF, THE ISSUING INSURER WILL ENDEAVOR TO MAIL _____ DAYS WRITTEN NOTICE TO THE CERTIFICATE HOLDER NAMED TO THE LEFT, BUT FAILURE TO DO SO SHALL IMPOSE NO OBLIGATION OR LIABILITY OF ANY KIND UPON THE INSURER, ITS AGENTS OR REPRESENTATIVES.<br>AUTHORIZED REPRESENTATIVE |
|--|--|





**CERTIFICATE OF FINANCE OFFICER**

Provisions for the payment of the monies to fall due under this agreement has been made by appropriation duly made or by bonds or notes duly authorized, as required by the "Local Government Budget and Fiscal Control Act".

---

Finance Officer

---

Date



**CERTIFICATE OF OWNER'S ATTORNEY**

I, the undersigned, \_\_\_\_\_,  
the duly authorized and acting legal representative of \_\_\_\_\_,  
\_\_\_\_\_ , do hereby certify as follows:

I have examined the attached Contract(s) and Performance and Payment Bonds and the manner of execution thereof, and I am of the opinion that each of the aforesaid agreements is adequate and has been duly executed by the proper parties thereto acting through their duly authorized representatives; that said representatives have full power and authority to execute said agreements on behalf of the respective parties named thereon; and that the foregoing agreements constitute valid and legally binding obligations upon the parties executing the same in accordance with terms, conditions, and provisions thereof.

\_\_\_\_\_

Date \_\_\_\_\_





## Contractor's Application for Payment No.

|   |   |
|---|---|
| To<br>(Owner):<br><br>Project:<br><br>Owner's Contract No.: | Application Period:<br><br>From (Contractor):<br><br>Contract:<br><br>Contractor's Project No.: |
|   | Application Date:<br><br>Via (Engineer):<br><br>Engineer's Project No.:                         |

### Application For Payment Change Order Summary

| Approved Change Orders | Additions | Deductions |
|------------------------|-----------|------------|
|                        |           |            |
|                        |           |            |
|                        |           |            |
|                        |           |            |
|                        |           |            |
|                        |           |            |
| TOTALS                 |           |            |
| NET CHANGE BY          |           |            |
| CHANGE ORDERS          |           |            |

1. ORIGINAL CONTRACT PRICE..... \$ \_\_\_\_\_
2. Net change by Change Orders..... \$ \_\_\_\_\_
3. Current Contract Price (Line 1 ± 2)..... \$ \_\_\_\_\_
4. TOTAL COMPLETED AND STORED TO DATE  
(Column F on Progress Estimate)..... \$ \_\_\_\_\_
5. RETAINAGE:
  - a.  Work Completed..... \$ \_\_\_\_\_
  - b.  Stored Material..... \$ \_\_\_\_\_
  - c. Total Retainage (Line 5a + Line 5b)..... \$ \_\_\_\_\_
6. AMOUNT ELIGIBLE TO DATE (Line 4 - Line 5c)..... \$ \_\_\_\_\_
7. LESS PREVIOUS PAYMENTS (Line 6 from prior Application)..... \$ \_\_\_\_\_
8. AMOUNT DUE THIS APPLICATION..... \$ \_\_\_\_\_
9. BALANCE TO FINISH, PLUS RETAINAGE  
(Column G on Progress Estimate + Line 5 above)..... \$ \_\_\_\_\_

|   |                              |
|---|------------------------------|
| <b>Contractor's Certification</b><br>The undersigned Contractor certifies that to the best of its knowledge: (1) all previous progress payments received from Owner on account of Work done under the Contract have been applied on account to discharge Contractor's legitimate obligations incurred in connection with Work covered by prior Applications for Payment; (2) title of all Work, materials and equipment incorporated in said Work or otherwise listed in or covered by this Application for Payment will pass to Owner at time of payment free and clear of all Liens, security interests and encumbrances (except such as are covered by a Bond acceptable to Owner indemnifying Owner against any such Liens, security interest or encumbrances); and (3) all Work covered by this Application for Payment is in accordance with the Contract Documents and is not defective. | By: _____<br><br>Date: _____ |
|---|------------------------------|

Payment of: \$ \_\_\_\_\_  
 (Line 8 or other - attach explanation of the other amount)

is recommended by: \_\_\_\_\_ (Date) \_\_\_\_\_ (Engineer)

Payment of: \$ \_\_\_\_\_  
 (Line 8 or other - attach explanation of the other amount)

is approved by: \_\_\_\_\_ (Date) \_\_\_\_\_ (Owner)

Approved by: \_\_\_\_\_ (Date) \_\_\_\_\_  
 Funding Agency (if applicable)

















# Certificate of Final Completion

Project: Northside Commercial Center – Sanitary Sewer Extension

Owner: Greenville Utilities Commission

Owner's Contract No.:

Contract: Sanitary Sewer Improvements

Engineer's Project No.:20049

**This [tentative] [definitive] Certificate of Final Completion applies to:**

- All Work under the Contract Documents:
- The following specified portions of the Work:

---



---



---



---

\_\_\_\_\_ Date of Final Completion

The Work to which this Certificate applies has been inspected by authorized representatives of Owner, Contractor, and Engineer, and found to be complete and ready for final payment. The Date of Final Completion of the Project or portion thereof designated above is hereby declared and is also the date of commencement of applicable warranties required by the Contract Documents, except as stated below.

A [tentative] [definitive] list of items to be completed or corrected is attached hereto. This list may not be all-inclusive, and the failure to include any items on such list does not alter the responsibility of the Contractor to complete all Work in accordance with the Contract Documents.

**The responsibilities between Owner and Contractor for security, operation, safety, maintenance, heat, utilities, insurance and warranties shall be as provided in the Contract Documents except as amended as follows:**

- Amended Responsibilities
- Not Amended

Owner's Amended Responsibilities:

---



---



---

Contractor's Amended Responsibilities:

---



---



---

The following documents are attached to and made part of this Certificate:

This Certificate does not constitute an acceptance of Work not in accordance with the Contract Documents nor is it a release of Contractor's obligation to complete the Work in accordance with the Contract Documents.

Executed by Engineer \_\_\_\_\_ Date \_\_\_\_\_

Accepted by Contractor \_\_\_\_\_ Date \_\_\_\_\_

Accepted by Owner \_\_\_\_\_ Date \_\_\_\_\_

**CONTRACTOR'S  
FINAL WAIVER OF LIEN,  
RELEASE, AFFIDAVIT, AND INDEMNIFICATION AGREEMENT**

FROM: \_\_\_\_\_  
\_\_\_\_\_  
\_\_\_\_\_  
\_\_\_\_\_  
\_\_\_\_\_  
\_\_\_\_\_  
(hereinafter "**Undersigned**" as Contractor)

TO: Greenville Utilities Commission  
401 S. Greene Street  
Greenville, NC 27834  
\_\_\_\_\_  
\_\_\_\_\_  
\_\_\_\_\_  
(hereinafter "**Owner**")

RE: Greenville Utilities Commission  
Northside Commercial Center  
Sanitary Sewer Extension  
\_\_\_\_\_  
\_\_\_\_\_  
\_\_\_\_\_

The Undersigned, in consideration of any and all previous payments made to it, (including the full and final payment) and other good and valuable considerations, hereby waives and releases all actions, debts, claims and demands against the Engineer, Owner, and its lender, title insurer, if any, their officers agents and representatives, on account of any and all work, including but not limited to: Labor; professional design or surveying services; materials; appliances; equipment; machinery; fixtures; or furnishings ("Work") performed and furnished by it, in connection with the making of improvements on or beneath the Real Property and for the Project of the Owner as referenced above; and

Hereby waives any and all right to have a mechanic's, laborer's, materialman's or other liens by virtue of the laws of North Carolina or any amendment of said laws, and all right to file any such liens or assert claims presently or in the future against bonds, funds, the Project or said Real Property relating to the Work; and

Hereby agrees to promptly: withdraw any claim against bonds; pay and release of record any and all mechanic's, laborers, materialman's and other liens filed or claimed by others in connection with the Undersigned's Work on the Project, which may now or in the future affect said Real Property: and to defend, indemnify and save Owner harmless from any claim, liability or expense (including attorney's fees) because of any such claims or liens or the enforcement thereof.

The Undersigned, on oath, states: that no UCC Financing Statement, security interest, conditional bill of sale or retention of title agreement, has been given or executed by the Undersigned

for or in connection with any material, appliances, machinery, fixtures or furnishings placed upon or installed in the Real Property and Project:

It is further understood that this document is submitted to the Owner for its reliance and assurance to others that all liens and claims relating to the Work furnished by the Undersigned are paid or resolved.

It is further understood and agreed that this document also constitutes an "instrument of satisfaction" which the Owner may exhibit, whereupon the Clerk of Superior Court shall cancel of record any and all liens by or through the Undersigned in connection with the Real Property and Project, all as provided by N.C.G.S. §44A-16(2) and as may be amended.

(Name of First Tier Contractor)

\_\_\_\_\_

By: \_\_\_\_\_

(Print) \_\_\_\_\_

Dated: \_\_\_\_\_

Title: \_\_\_\_\_

Authorized Representative

STATE OF NORTH CAROLINA  
COUNTY OF \_\_\_\_\_

Subscribed and sworn to before me this \_\_\_\_\_ day of \_\_\_\_\_, 20\_\_.

\_\_\_\_\_

NOTARY PUBLIC

My Commission Expires:

\_\_\_\_\_



# STANDARD GENERAL CONDITIONS OF THE CONSTRUCTION CONTRACT

Prepared by

**ENGINEERS JOINT CONTRACT DOCUMENTS COMMITTEE**

and

Issued and Published Jointly by



AMERICAN COUNCIL OF ENGINEERING COMPANIES

ASSOCIATED GENERAL CONTRACTORS OF AMERICA

AMERICAN SOCIETY OF CIVIL ENGINEERS

PROFESSIONAL ENGINEERS IN PRIVATE PRACTICE  
*A Practice Division of the*  
NATIONAL SOCIETY OF PROFESSIONAL ENGINEERS

Endorsed by



CONSTRUCTION SPECIFICATIONS INSTITUTE

These General Conditions have been prepared for use with the Suggested Forms of Agreement Between Owner and Contractor (EJCDC C-520 or C-525, 2007 Editions). Their provisions are interrelated and a change in one may necessitate a change in the other. Comments concerning their usage are contained in the Narrative Guide to the EJCDC Construction Documents (EJCDC C-001, 2007 Edition). For guidance in the preparation of Supplementary Conditions, see Guide to the Preparation of Supplementary Conditions (EJCDC C-800, 2007 Edition).

Copyright © 2007 National Society of Professional Engineers  
1420 King Street, Alexandria, VA 22314-2794  
(703) 684-2882  
[www.nspe.org](http://www.nspe.org)

American Council of Engineering Companies  
1015 15th Street N.W., Washington, DC 20005  
(202) 347-7474  
[www.acec.org](http://www.acec.org)

American Society of Civil Engineers  
1801 Alexander Bell Drive, Reston, VA 20191-4400  
(800) 548-2723  
[www.asce.org](http://www.asce.org)

Associated General Contractors of America  
2300 Wilson Boulevard, Suite 400, Arlington, VA 22201-3308  
(703) 548-3118  
[www.agc.org](http://www.agc.org)

The copyright for this EJCDC document is owned jointly by the four EJCDC sponsoring organizations and held in trust for their benefit by NSPE.

# STANDARD GENERAL CONDITIONS OF THE CONSTRUCTION CONTRACT

## TABLE OF CONTENTS

|  | Page |
|--|------|
| Article 1 – Definitions and Terminology.....   | 1    |
| 1.01 Defined Terms .....   | 1    |
| 1.02 Terminology.....  | 5    |
| Article 2 – Preliminary Matters.....   | 6    |
| 2.01 Delivery of Bonds and Evidence of Insurance .....   | 6    |
| 2.02 Copies of Documents .....   | 6    |
| 2.03 Commencement of Contract Times; Notice to Proceed .....   | 6    |
| 2.04 Starting the Work .....   | 7    |
| 2.05 Before Starting Construction .....  | 7    |
| 2.06 Preconstruction Conference; Designation of Authorized Representatives .....   | 7    |
| 2.07 Initial Acceptance of Schedules .....   | 7    |
| Article 3 – Contract Documents: Intent, Amending, Reuse.....   | 8    |
| 3.01 Intent .....  | 8    |
| 3.02 Reference Standards .....   | 8    |
| 3.03 Reporting and Resolving Discrepancies.....  | 9    |
| 3.04 Amending and Supplementing Contract Documents .....   | 9    |
| 3.05 Reuse of Documents .....  | 10   |
| 3.06 Electronic Data .....   | 10   |
| Article 4 – Availability of Lands; Subsurface and Physical Conditions; Hazardous Environmental Conditions;<br>Reference Points ..... | 11   |
| 4.01 Availability of Lands.....  | 11   |
| 4.02 Subsurface and Physical Conditions .....  | 11   |
| 4.03 Differing Subsurface or Physical Conditions.....  | 12   |
| 4.04 Underground Facilities .....  | 13   |
| 4.05 Reference Points .....  | 14   |
| 4.06 Hazardous Environmental Condition at Site .....   | 14   |
| Article 5 – Bonds and Insurance .....  | 16   |
| 5.01 Performance, Payment, and Other Bonds .....   | 16   |
| 5.02 Licensed Sureties and Insurers .....  | 16   |
| 5.03 Certificates of Insurance .....   | 17   |
| 5.04 Contractor’s Insurance .....  | 17   |
| 5.05 Owner’s Liability Insurance .....   | 19   |
| 5.06 Property Insurance .....  | 19   |

|  |  |    |
|--|--|----|
| 5.07   | Waiver of Rights .....                                       | 20 |
| 5.08   | Receipt and Application of Insurance Proceeds.....           | 21 |
| 5.09   | Acceptance of Bonds and Insurance; Option to Replace.....    | 21 |
| 5.10   | Partial Utilization, Acknowledgment of Property Insurer..... | 22 |
| Article 6 – Contractor’s Responsibilities..... |  | 22 |
| 6.01   | Supervision and Superintendence.....                         | 22 |
| 6.02   | Labor; Working Hours .....                                   | 22 |
| 6.03   | Services, Materials, and Equipment .....                     | 22 |
| 6.04   | Progress Schedule .....                                      | 23 |
| 6.05   | Substitutes and “Or-Equals” .....                            | 23 |
| 6.06   | Concerning Subcontractors, Suppliers, and Others .....       | 25 |
| 6.07   | Patent Fees and Royalties .....                              | 27 |
| 6.08   | Permits.....   | 27 |
| 6.09   | Laws and Regulations .....                                   | 28 |
| 6.10   | Taxes .....  | 28 |
| 6.11   | Use of Site and Other Areas.....                             | 28 |
| 6.12   | Record Documents .....                                       | 29 |
| 6.13   | Safety and Protection.....                                   | 29 |
| 6.14   | Safety Representative .....                                  | 30 |
| 6.15   | Hazard Communication Programs.....                           | 30 |
| 6.16   | Emergencies .....  | 30 |
| 6.17   | Shop Drawings and Samples.....                               | 31 |
| 6.18   | Continuing the Work.....                                     | 32 |
| 6.19   | Contractor’s General Warranty and Guarantee.....             | 33 |
| 6.20   | Indemnification .....  | 33 |
| 6.21   | Delegation of Professional Design Services.....              | 34 |
| Article 7 – Other Work at the Site .....       |  | 35 |
| 7.01   | Related Work at Site .....                                   | 35 |
| 7.02   | Coordination.....  | 35 |
| 7.03   | Legal Relationships.....                                     | 36 |
| Article 8 – Owner’s Responsibilities .....     |  | 36 |
| 8.01   | Communications to Contractor .....                           | 36 |
| 8.02   | Replacement of Engineer.....                                 | 36 |
| 8.03   | Furnish Data .....   | 36 |
| 8.04   | Pay When Due .....   | 36 |
| 8.05   | Lands and Easements; Reports and Tests .....                 | 36 |
| 8.06   | Insurance .....  | 36 |
| 8.07   | Change Orders.....   | 37 |
| 8.08   | Inspections, Tests, and Approvals.....                       | 37 |
| 8.09   | Limitations on Owner’s Responsibilities.....                 | 37 |
| 8.10   | Undisclosed Hazardous Environmental Condition.....           | 37 |
| 8.11   | Evidence of Financial Arrangements .....                     | 37 |

|  |    |
|--|----|
| 8.12 Compliance with Safety Program .....  | 37 |
| Article 9 – Engineer’s Status During Construction .....                                      | 37 |
| 9.01 Owner’s Representative.....   | 37 |
| 9.02 Visits to Site .....  | 37 |
| 9.03 Project Representative.....   | 38 |
| 9.04 Authorized Variations in Work .....   | 38 |
| 9.05 Rejecting Defective Work.....   | 38 |
| 9.06 Shop Drawings, Change Orders and Payments.....  | 39 |
| 9.07 Determinations for Unit Price Work.....   | 39 |
| 9.08 Decisions on Requirements of Contract Documents and Acceptability of Work .....         | 39 |
| 9.09 Limitations on Engineer’s Authority and Responsibilities .....                          | 39 |
| 9.10 Compliance with Safety Program .....  | 40 |
| Article 10 – Changes in the Work; Claims .....   | 40 |
| 10.01 Authorized Changes in the Work.....  | 40 |
| 10.02 Unauthorized Changes in the Work .....   | 41 |
| 10.03 Execution of Change Orders .....   | 41 |
| 10.04 Notification to Surety.....  | 41 |
| 10.05 Claims.....  | 41 |
| Article 11 – Cost of the Work; Allowances; Unit Price Work.....                              | 42 |
| 11.01 Cost of the Work .....   | 42 |
| 11.02 Allowances.....  | 45 |
| 11.03 Unit Price Work .....  | 45 |
| Article 12 – Change of Contract Price; Change of Contract Times.....                         | 46 |
| 12.01 Change of Contract Price .....   | 46 |
| 12.02 Change of Contract Times.....  | 47 |
| 12.03 Delays.....  | 47 |
| Article 13 – Tests and Inspections; Correction, Removal or Acceptance of Defective Work..... | 48 |
| 13.01 Notice of Defects.....   | 48 |
| 13.02 Access to Work .....   | 48 |
| 13.03 Tests and Inspections .....  | 49 |
| 13.04 Uncovering Work.....   | 49 |
| 13.05 Owner May Stop the Work .....  | 50 |
| 13.06 Correction or Removal of Defective Work .....  | 50 |
| 13.07 Correction Period .....  | 50 |
| 13.08 Acceptance of Defective Work .....   | 51 |
| 13.09 Owner May Correct Defective Work .....   | 52 |
| Article 14 – Payments to Contractor and Completion.....                                      | 52 |
| 14.01 Schedule of Values .....   | 52 |
| 14.02 Progress Payments .....  | 52 |
| 14.03 Contractor’s Warranty of Title.....  | 55 |

|   |    |
|---|----|
| 14.04 Substantial Completion .....                    | 55 |
| 14.05 Partial Utilization .....                       | 56 |
| 14.06 Final Inspection .....                          | 57 |
| 14.07 Final Payment .....                             | 57 |
| 14.08 Final Completion Delayed .....                  | 58 |
| 14.09 Waiver of Claims.....                           | 58 |
| Article 15 – Suspension of Work and Termination ..... | 59 |
| 15.01 Owner May Suspend Work .....                    | 59 |
| 15.02 Owner May Terminate for Cause .....             | 59 |
| 15.03 Owner May Terminate For Convenience .....       | 60 |
| 15.04 Contractor May Stop Work or Terminate .....     | 60 |
| Article 16 – Dispute Resolution .....                 | 61 |
| 16.01 Methods and Procedures.....                     | 61 |
| Article 17 – Miscellaneous.....                       | 61 |
| 17.01 Giving Notice .....                             | 61 |
| 17.02 Computation of Times.....                       | 62 |
| 17.03 Cumulative Remedies.....                        | 62 |
| 17.04 Survival of Obligations.....                    | 62 |
| 17.05 Controlling Law.....                            | 62 |
| 17.06 Headings .....                                  | 62 |

## ARTICLE 1 – DEFINITIONS AND TERMINOLOGY

### 1.01 *Defined Terms*

- A. Wherever used in the Bidding Requirements or Contract Documents and printed with initial capital letters, the terms listed below will have the meanings indicated which are applicable to both the singular and plural thereof. In addition to terms specifically defined, terms with initial capital letters in the Contract Documents include references to identified articles and paragraphs, and the titles of other documents or forms.
1. *Addenda*—Written or graphic instruments issued prior to the opening of Bids which clarify, correct, or change the Bidding Requirements or the proposed Contract Documents.
  2. *Agreement*—The written instrument which is evidence of the agreement between Owner and Contractor covering the Work.
  3. *Application for Payment*—The form acceptable to Engineer which is to be used by Contractor during the course of the Work in requesting progress or final payments and which is to be accompanied by such supporting documentation as is required by the Contract Documents.
  4. *Asbestos*—Any material that contains more than one percent asbestos and is friable or is releasing asbestos fibers into the air above current action levels established by the United States Occupational Safety and Health Administration.
  5. *Bid*—The offer or proposal of a Bidder submitted on the prescribed form setting forth the prices for the Work to be performed.
  6. *Bidder*—The individual or entity who submits a Bid directly to Owner.
  7. *Bidding Documents*—The Bidding Requirements and the proposed Contract Documents (including all Addenda).
  8. *Bidding Requirements*—The advertisement or invitation to bid, Instructions to Bidders, Bid security of acceptable form, if any, and the Bid Form with any supplements.
  9. *Change Order*—A document recommended by Engineer which is signed by Contractor and Owner and authorizes an addition, deletion, or revision in the Work or an adjustment in the Contract Price or the Contract Times, issued on or after the Effective Date of the Agreement.
  10. *Claim*—A demand or assertion by Owner or Contractor seeking an adjustment of Contract Price or Contract Times, or both, or other relief with respect to the terms of the Contract. A demand for money or services by a third party is not a Claim.

11. *Contract*—The entire and integrated written agreement between the Owner and Contractor concerning the Work. The Contract supersedes prior negotiations, representations, or agreements, whether written or oral.
12. *Contract Documents*—Those items so designated in the Agreement. Only printed or hard copies of the items listed in the Agreement are Contract Documents. Approved Shop Drawings, other Contractor submittals, and the reports and drawings of subsurface and physical conditions are not Contract Documents.
13. *Contract Price*—The moneys payable by Owner to Contractor for completion of the Work in accordance with the Contract Documents as stated in the Agreement (subject to the provisions of Paragraph 11.03 in the case of Unit Price Work).
14. *Contract Times*—The number of days or the dates stated in the Agreement to: (i) achieve Milestones, if any; (ii) achieve Substantial Completion; and (iii) complete the Work so that it is ready for final payment as evidenced by Engineer’s written recommendation of final payment.
15. *Contractor*—The individual or entity with whom Owner has entered into the Agreement.
16. *Cost of the Work*—See Paragraph 11.01 for definition.
17. *Drawings*—That part of the Contract Documents prepared or approved by Engineer which graphically shows the scope, extent, and character of the Work to be performed by Contractor. Shop Drawings and other Contractor submittals are not Drawings as so defined.
18. *Effective Date of the Agreement*—The date indicated in the Agreement on which it becomes effective, but if no such date is indicated, it means the date on which the Agreement is signed and delivered by the last of the two parties to sign and deliver.
19. *Engineer*—The individual or entity named as such in the Agreement.
20. *Field Order*—A written order issued by Engineer which requires minor changes in the Work but which does not involve a change in the Contract Price or the Contract Times.
21. *General Requirements*—Sections of Division 1 of the Specifications.
22. *Hazardous Environmental Condition*—The presence at the Site of Asbestos, PCBs, Petroleum, Hazardous Waste, or Radioactive Material in such quantities or circumstances that may present a substantial danger to persons or property exposed thereto.
23. *Hazardous Waste*—The term Hazardous Waste shall have the meaning provided in Section 1004 of the Solid Waste Disposal Act (42 USC Section 6903) as amended from time to time.



24. *Laws and Regulations; Laws or Regulations*—Any and all applicable laws, rules, regulations, ordinances, codes, and orders of any and all governmental bodies, agencies, authorities, and courts having jurisdiction.
25. *Liens*—Charges, security interests, or encumbrances upon Project funds, real property, or personal property.
26. *Milestone*—A principal event specified in the Contract Documents relating to an intermediate completion date or time prior to Substantial Completion of all the Work.
27. *Notice of Award*—The written notice by Owner to the Successful Bidder stating that upon timely compliance by the Successful Bidder with the conditions precedent listed therein, Owner will sign and deliver the Agreement.
28. *Notice to Proceed*—A written notice given by Owner to Contractor fixing the date on which the Contract Times will commence to run and on which Contractor shall start to perform the Work under the Contract Documents.
29. *Owner*—The individual or entity with whom Contractor has entered into the Agreement and for whom the Work is to be performed.
30. *PCBs*—Polychlorinated biphenyls.
31. *Petroleum*—Petroleum, including crude oil or any fraction thereof which is liquid at standard conditions of temperature and pressure (60 degrees Fahrenheit and 14.7 pounds per square inch absolute), such as oil, petroleum, fuel oil, oil sludge, oil refuse, gasoline, kerosene, and oil mixed with other non-Hazardous Waste and crude oils.
32. *Progress Schedule*—A schedule, prepared and maintained by Contractor, describing the sequence and duration of the activities comprising the Contractor's plan to accomplish the Work within the Contract Times.
33. *Project*—The total construction of which the Work to be performed under the Contract Documents may be the whole, or a part.
34. *Project Manual*—The bound documentary information prepared for bidding and constructing the Work. A listing of the contents of the Project Manual, which may be bound in one or more volumes, is contained in the table(s) of contents.
35. *Radioactive Material*—Source, special nuclear, or byproduct material as defined by the Atomic Energy Act of 1954 (42 USC Section 2011 et seq.) as amended from time to time.
36. *Resident Project Representative*—The authorized representative of Engineer who may be assigned to the Site or any part thereof.

37. *Samples*—Physical examples of materials, equipment, or workmanship that are representative of some portion of the Work and which establish the standards by which such portion of the Work will be judged.
38. *Schedule of Submittals*—A schedule, prepared and maintained by Contractor, of required submittals and the time requirements to support scheduled performance of related construction activities.
39. *Schedule of Values*—A schedule, prepared and maintained by Contractor, allocating portions of the Contract Price to various portions of the Work and used as the basis for reviewing Contractor’s Applications for Payment.
40. *Shop Drawings*—All drawings, diagrams, illustrations, schedules, and other data or information which are specifically prepared or assembled by or for Contractor and submitted by Contractor to illustrate some portion of the Work.
41. *Site*—Lands or areas indicated in the Contract Documents as being furnished by Owner upon which the Work is to be performed, including rights-of-way and easements for access thereto, and such other lands furnished by Owner which are designated for the use of Contractor.
42. *Specifications*—That part of the Contract Documents consisting of written requirements for materials, equipment, systems, standards and workmanship as applied to the Work, and certain administrative requirements and procedural matters applicable thereto.
43. *Subcontractor*—An individual or entity having a direct contract with Contractor or with any other Subcontractor for the performance of a part of the Work at the Site.
44. *Substantial Completion*—The time at which the Work (or a specified part thereof) has progressed to the point where, in the opinion of Engineer, the Work (or a specified part thereof) is sufficiently complete, in accordance with the Contract Documents, so that the Work (or a specified part thereof) can be utilized for the purposes for which it is intended. The terms “substantially complete” and “substantially completed” as applied to all or part of the Work refer to Substantial Completion thereof.
45. *Successful Bidder*—The Bidder submitting a responsive Bid to whom Owner makes an award.
46. *Supplementary Conditions*—That part of the Contract Documents which amends or supplements these General Conditions.
47. *Supplier*—A manufacturer, fabricator, supplier, distributor, materialman, or vendor having a direct contract with Contractor or with any Subcontractor to furnish materials or equipment to be incorporated in the Work by Contractor or Subcontractor.
48. *Underground Facilities*—All underground pipelines, conduits, ducts, cables, wires, manholes, vaults, tanks, tunnels, or other such facilities or attachments, and any

encasements containing such facilities, including those that convey electricity, gases, steam, liquid petroleum products, telephone or other communications, cable television, water, wastewater, storm water, other liquids or chemicals, or traffic or other control systems.

49. *Unit Price Work*—Work to be paid for on the basis of unit prices.
50. *Work*—The entire construction or the various separately identifiable parts thereof required to be provided under the Contract Documents. Work includes and is the result of performing or providing all labor, services, and documentation necessary to produce such construction, and furnishing, installing, and incorporating all materials and equipment into such construction, all as required by the Contract Documents.
51. *Work Change Directive*—A written statement to Contractor issued on or after the Effective Date of the Agreement and signed by Owner and recommended by Engineer ordering an addition, deletion, or revision in the Work, or responding to differing or unforeseen subsurface or physical conditions under which the Work is to be performed or to emergencies. A Work Change Directive will not change the Contract Price or the Contract Times but is evidence that the parties expect that the change ordered or documented by a Work Change Directive will be incorporated in a subsequently issued Change Order following negotiations by the parties as to its effect, if any, on the Contract Price or Contract Times.

## 1.02 *Terminology*

- A. The words and terms discussed in Paragraph 1.02.B through F are not defined but, when used in the Bidding Requirements or Contract Documents, have the indicated meaning.
- B. *Intent of Certain Terms or Adjectives:*
  1. The Contract Documents include the terms “as allowed,” “as approved,” “as ordered,” “as directed” or terms of like effect or import to authorize an exercise of professional judgment by Engineer. In addition, the adjectives “reasonable,” “suitable,” “acceptable,” “proper,” “satisfactory,” or adjectives of like effect or import are used to describe an action or determination of Engineer as to the Work. It is intended that such exercise of professional judgment, action, or determination will be solely to evaluate, in general, the Work for compliance with the information in the Contract Documents and with the design concept of the Project as a functioning whole as shown or indicated in the Contract Documents (unless there is a specific statement indicating otherwise). The use of any such term or adjective is not intended to and shall not be effective to assign to Engineer any duty or authority to supervise or direct the performance of the Work, or any duty or authority to undertake responsibility contrary to the provisions of Paragraph 9.09 or any other provision of the Contract Documents.
- C. *Day:*

1. The word “day” means a calendar day of 24 hours measured from midnight to the next midnight.

D. *Defective:*

1. The word “defective,” when modifying the word “Work,” refers to Work that is unsatisfactory, faulty, or deficient in that it:
  - a. does not conform to the Contract Documents; or
  - b. does not meet the requirements of any applicable inspection, reference standard, test, or approval referred to in the Contract Documents; or
  - c. has been damaged prior to Engineer’s recommendation of final payment (unless responsibility for the protection thereof has been assumed by Owner at Substantial Completion in accordance with Paragraph 14.04 or 14.05).

E. *Furnish, Install, Perform, Provide:*

1. The word “furnish,” when used in connection with services, materials, or equipment, shall mean to supply and deliver said services, materials, or equipment to the Site (or some other specified location) ready for use or installation and in usable or operable condition.
  2. The word “install,” when used in connection with services, materials, or equipment, shall mean to put into use or place in final position said services, materials, or equipment complete and ready for intended use.
  3. The words “perform” or “provide,” when used in connection with services, materials, or equipment, shall mean to furnish and install said services, materials, or equipment complete and ready for intended use.
  4. When “furnish,” “install,” “perform,” or “provide” is not used in connection with services, materials, or equipment in a context clearly requiring an obligation of Contractor, “provide” is implied.
- F. Unless stated otherwise in the Contract Documents, words or phrases that have a well-known technical or construction industry or trade meaning are used in the Contract Documents in accordance with such recognized meaning.

## **ARTICLE 2 – PRELIMINARY MATTERS**

### **2.01 *Delivery of Bonds and Evidence of Insurance***

- A. When Contractor delivers the executed counterparts of the Agreement to Owner, Contractor shall also deliver to Owner such bonds as Contractor may be required to furnish.
- B. *Evidence of Insurance:* Before any Work at the Site is started, Contractor and Owner shall each deliver to the other, with copies to each additional insured identified in the Supplementary

Conditions, certificates of insurance (and other evidence of insurance which either of them or any additional insured may reasonably request) which Contractor and Owner respectively are required to purchase and maintain in accordance with Article 5.

#### 2.02 *Copies of Documents*

- A. Owner shall furnish to Contractor up to ten printed or hard copies of the Drawings and Project Manual. Additional copies will be furnished upon request at the cost of reproduction.

#### 2.03 *Commencement of Contract Times; Notice to Proceed*

- A. The Contract Times will commence to run on the thirtieth day after the Effective Date of the Agreement or, if a Notice to Proceed is given, on the day indicated in the Notice to Proceed. A Notice to Proceed may be given at any time within 30 days after the Effective Date of the Agreement. In no event will the Contract Times commence to run later than the sixtieth day after the day of Bid opening or the thirtieth day after the Effective Date of the Agreement, whichever date is earlier.

#### 2.04 *Starting the Work*

- A. Contractor shall start to perform the Work on the date when the Contract Times commence to run. No Work shall be done at the Site prior to the date on which the Contract Times commence to run.

#### 2.05 *Before Starting Construction*

- A. *Preliminary Schedules:* Within 10 days after the Effective Date of the Agreement (unless otherwise specified in the General Requirements), Contractor shall submit to Engineer for timely review:
  - 1. a preliminary Progress Schedule indicating the times (numbers of days or dates) for starting and completing the various stages of the Work, including any Milestones specified in the Contract Documents;
  - 2. a preliminary Schedule of Submittals; and
  - 3. a preliminary Schedule of Values for all of the Work which includes quantities and prices of items which when added together equal the Contract Price and subdivides the Work into component parts in sufficient detail to serve as the basis for progress payments during performance of the Work. Such prices will include an appropriate amount of overhead and profit applicable to each item of Work.

#### 2.06 *Preconstruction Conference; Designation of Authorized Representatives*

- A. Before any Work at the Site is started, a conference attended by Owner, Contractor, Engineer, and others as appropriate will be held to establish a working understanding among the parties as to the Work and to discuss the schedules referred to in Paragraph 2.05.A, procedures for

handling Shop Drawings and other submittals, processing Applications for Payment, and maintaining required records.

- B. At this conference Owner and Contractor each shall designate, in writing, a specific individual to act as its authorized representative with respect to the services and responsibilities under the Contract. Such individuals shall have the authority to transmit instructions, receive information, render decisions relative to the Contract, and otherwise act on behalf of each respective party.

#### 2.07 *Initial Acceptance of Schedules*

- A. At least 10 days before submission of the first Application for Payment a conference attended by Contractor, Engineer, and others as appropriate will be held to review for acceptability to Engineer as provided below the schedules submitted in accordance with Paragraph 2.05.A. Contractor shall have an additional 10 days to make corrections and adjustments and to complete and resubmit the schedules. No progress payment shall be made to Contractor until acceptable schedules are submitted to Engineer.
  - 1. The Progress Schedule will be acceptable to Engineer if it provides an orderly progression of the Work to completion within the Contract Times. Such acceptance will not impose on Engineer responsibility for the Progress Schedule, for sequencing, scheduling, or progress of the Work, nor interfere with or relieve Contractor from Contractor's full responsibility therefor.
  - 2. Contractor's Schedule of Submittals will be acceptable to Engineer if it provides a workable arrangement for reviewing and processing the required submittals.
  - 3. Contractor's Schedule of Values will be acceptable to Engineer as to form and substance if it provides a reasonable allocation of the Contract Price to component parts of the Work.

### **ARTICLE 3 – CONTRACT DOCUMENTS: INTENT, AMENDING, REUSE**

#### 3.01 *Intent*

- A. The Contract Documents are complementary; what is required by one is as binding as required by all.
- B. It is the intent of the Contract Documents to describe a functionally complete project (or part thereof) to be constructed in accordance with the Contract Documents. Any labor, documentation, services, materials, or equipment that reasonably may be inferred from the Contract Documents or from prevailing custom or trade usage as being required to produce the indicated result will be provided whether or not specifically called for, at no additional cost to Owner.
- C. Clarifications and interpretations of the Contract Documents shall be issued by Engineer as provided in Article 9.

### 3.02 *Reference Standards*

#### A. Standards, Specifications, Codes, Laws, and Regulations

1. Reference to standards, specifications, manuals, or codes of any technical society, organization, or association, or to Laws or Regulations, whether such reference be specific or by implication, shall mean the standard, specification, manual, code, or Laws or Regulations in effect at the time of opening of Bids (or on the Effective Date of the Agreement if there were no Bids), except as may be otherwise specifically stated in the Contract Documents.
2. No provision of any such standard, specification, manual, or code, or any instruction of a Supplier, shall be effective to change the duties or responsibilities of Owner, Contractor, or Engineer, or any of their subcontractors, consultants, agents, or employees, from those set forth in the Contract Documents. No such provision or instruction shall be effective to assign to Owner, Engineer, or any of their officers, directors, members, partners, employees, agents, consultants, or subcontractors, any duty or authority to supervise or direct the performance of the Work or any duty or authority to undertake responsibility inconsistent with the provisions of the Contract Documents.

### 3.03 *Reporting and Resolving Discrepancies*

#### A. *Reporting Discrepancies:*

1. *Contractor's Review of Contract Documents Before Starting Work:* Before undertaking each part of the Work, Contractor shall carefully study and compare the Contract Documents and check and verify pertinent figures therein and all applicable field measurements. Contractor shall promptly report in writing to Engineer any conflict, error, ambiguity, or discrepancy which Contractor discovers, or has actual knowledge of, and shall obtain a written interpretation or clarification from Engineer before proceeding with any Work affected thereby.
2. *Contractor's Review of Contract Documents During Performance of Work:* If, during the performance of the Work, Contractor discovers any conflict, error, ambiguity, or discrepancy within the Contract Documents, or between the Contract Documents and (a) any applicable Law or Regulation, (b) any standard, specification, manual, or code, or (c) any instruction of any Supplier, then Contractor shall promptly report it to Engineer in writing. Contractor shall not proceed with the Work affected thereby (except in an emergency as required by Paragraph 6.16.A) until an amendment or supplement to the Contract Documents has been issued by one of the methods indicated in Paragraph 3.04.
3. Contractor shall not be liable to Owner or Engineer for failure to report any conflict, error, ambiguity, or discrepancy in the Contract Documents unless Contractor had actual knowledge thereof.

#### B. *Resolving Discrepancies:*

1. Except as may be otherwise specifically stated in the Contract Documents, the provisions of the Contract Documents shall take precedence in resolving any conflict, error, ambiguity, or discrepancy between the provisions of the Contract Documents and:
  - a. the provisions of any standard, specification, manual, or code, or the instruction of any Supplier (whether or not specifically incorporated by reference in the Contract Documents); or
  - b. the provisions of any Laws or Regulations applicable to the performance of the Work (unless such an interpretation of the provisions of the Contract Documents would result in violation of such Law or Regulation).

#### 3.04 *Amending and Supplementing Contract Documents*

- A. The Contract Documents may be amended to provide for additions, deletions, and revisions in the Work or to modify the terms and conditions thereof by either a Change Order or a Work Change Directive.
- B. The requirements of the Contract Documents may be supplemented, and minor variations and deviations in the Work may be authorized, by one or more of the following ways:
  1. A Field Order;
  2. Engineer's approval of a Shop Drawing or Sample (subject to the provisions of Paragraph 6.17.D.3); or
  3. Engineer's written interpretation or clarification.

#### 3.05 *Reuse of Documents*

- A. Contractor and any Subcontractor or Supplier shall not:
  1. have or acquire any title to or ownership rights in any of the Drawings, Specifications, or other documents (or copies of any thereof) prepared by or bearing the seal of Engineer or its consultants, including electronic media editions; or
  2. reuse any such Drawings, Specifications, other documents, or copies thereof on extensions of the Project or any other project without written consent of Owner and Engineer and specific written verification or adaptation by Engineer.
- B. The prohibitions of this Paragraph 3.05 will survive final payment, or termination of the Contract. Nothing herein shall preclude Contractor from retaining copies of the Contract Documents for record purposes.

#### 3.06 *Electronic Data*

- A. Unless otherwise stated in the Supplementary Conditions, the data furnished by Owner or Engineer to Contractor, or by Contractor to Owner or Engineer, that may be relied upon are



limited to the printed copies (also known as hard copies). Files in electronic media format of text, data, graphics, or other types are furnished only for the convenience of the receiving party. Any conclusion or information obtained or derived from such electronic files will be at the user's sole risk. If there is a discrepancy between the electronic files and the hard copies, the hard copies govern.

- B. Because data stored in electronic media format can deteriorate or be modified inadvertently or otherwise without authorization of the data's creator, the party receiving electronic files agrees that it will perform acceptance tests or procedures within 60 days, after which the receiving party shall be deemed to have accepted the data thus transferred. Any errors detected within the 60-day acceptance period will be corrected by the transferring party.
- C. When transferring documents in electronic media format, the transferring party makes no representations as to long term compatibility, usability, or readability of documents resulting from the use of software application packages, operating systems, or computer hardware differing from those used by the data's creator.

#### **ARTICLE 4 – AVAILABILITY OF LANDS; SUBSURFACE AND PHYSICAL CONDITIONS; HAZARDOUS ENVIRONMENTAL CONDITIONS; REFERENCE POINTS**

##### **4.01 *Availability of Lands***

- A. Owner shall furnish the Site. Owner shall notify Contractor of any encumbrances or restrictions not of general application but specifically related to use of the Site with which Contractor must comply in performing the Work. Owner will obtain in a timely manner and pay for easements for permanent structures or permanent changes in existing facilities. If Contractor and Owner are unable to agree on entitlement to or on the amount or extent, if any, of any adjustment in the Contract Price or Contract Times, or both, as a result of any delay in Owner's furnishing the Site or a part thereof, Contractor may make a Claim therefor as provided in Paragraph 10.05.
- B. Upon reasonable written request, Owner shall furnish Contractor with a current statement of record legal title and legal description of the lands upon which the Work is to be performed and Owner's interest therein as necessary for giving notice of or filing a mechanic's or construction lien against such lands in accordance with applicable Laws and Regulations.
- C. Contractor shall provide for all additional lands and access thereto that may be required for temporary construction facilities or storage of materials and equipment.

##### **4.02 *Subsurface and Physical Conditions***

- A. *Reports and Drawings:* The Supplementary Conditions identify:
  - 1. those reports known to Owner of explorations and tests of subsurface conditions at or contiguous to the Site; and
  - 2. those drawings known to Owner of physical conditions relating to existing surface or subsurface structures at the Site (except Underground Facilities).

B. *Limited Reliance by Contractor on Technical Data Authorized:* Contractor may rely upon the accuracy of the “technical data” contained in such reports and drawings, but such reports and drawings are not Contract Documents. Such “technical data” is identified in the Supplementary Conditions. Except for such reliance on such “technical data,” Contractor may not rely upon or make any claim against Owner or Engineer, or any of their officers, directors, members, partners, employees, agents, consultants, or subcontractors with respect to:

1. the completeness of such reports and drawings for Contractor’s purposes, including, but not limited to, any aspects of the means, methods, techniques, sequences, and procedures of construction to be employed by Contractor, and safety precautions and programs incident thereto; or
2. other data, interpretations, opinions, and information contained in such reports or shown or indicated in such drawings; or
3. any Contractor interpretation of or conclusion drawn from any “technical data” or any such other data, interpretations, opinions, or information.

#### 4.03 *Differing Subsurface or Physical Conditions*

A. *Notice:* If Contractor believes that any subsurface or physical condition that is uncovered or revealed either:

1. is of such a nature as to establish that any “technical data” on which Contractor is entitled to rely as provided in Paragraph 4.02 is materially inaccurate; or
2. is of such a nature as to require a change in the Contract Documents; or
3. differs materially from that shown or indicated in the Contract Documents; or
4. is of an unusual nature, and differs materially from conditions ordinarily encountered and generally recognized as inherent in work of the character provided for in the Contract Documents;

then Contractor shall, promptly after becoming aware thereof and before further disturbing the subsurface or physical conditions or performing any Work in connection therewith (except in an emergency as required by Paragraph 6.16.A), notify Owner and Engineer in writing about such condition. Contractor shall not further disturb such condition or perform any Work in connection therewith (except as aforesaid) until receipt of written order to do so.

B. *Engineer’s Review:* After receipt of written notice as required by Paragraph 4.03.A, Engineer will promptly review the pertinent condition, determine the necessity of Owner’s obtaining additional exploration or tests with respect thereto, and advise Owner in writing (with a copy to Contractor) of Engineer’s findings and conclusions.

C. *Possible Price and Times Adjustments:*

1. The Contract Price or the Contract Times, or both, will be equitably adjusted to the extent that the existence of such differing subsurface or physical condition causes an increase or decrease in Contractor's cost of, or time required for, performance of the Work; subject, however, to the following:
  - a. such condition must meet any one or more of the categories described in Paragraph 4.03.A; and
  - b. with respect to Work that is paid for on a unit price basis, any adjustment in Contract Price will be subject to the provisions of Paragraphs 9.07 and 11.03.
2. Contractor shall not be entitled to any adjustment in the Contract Price or Contract Times if:
  - a. Contractor knew of the existence of such conditions at the time Contractor made a final commitment to Owner with respect to Contract Price and Contract Times by the submission of a Bid or becoming bound under a negotiated contract; or
  - b. the existence of such condition could reasonably have been discovered or revealed as a result of any examination, investigation, exploration, test, or study of the Site and contiguous areas required by the Bidding Requirements or Contract Documents to be conducted by or for Contractor prior to Contractor's making such final commitment; or
  - c. Contractor failed to give the written notice as required by Paragraph 4.03.A.
3. If Owner and Contractor are unable to agree on entitlement to or on the amount or extent, if any, of any adjustment in the Contract Price or Contract Times, or both, a Claim may be made therefor as provided in Paragraph 10.05. However, neither Owner or Engineer, or any of their officers, directors, members, partners, employees, agents, consultants, or subcontractors shall be liable to Contractor for any claims, costs, losses, or damages (including but not limited to all fees and charges of engineers, architects, attorneys, and other professionals and all court or arbitration or other dispute resolution costs) sustained by Contractor on or in connection with any other project or anticipated project.

#### 4.04 *Underground Facilities*

- A. *Shown or Indicated:* The information and data shown or indicated in the Contract Documents with respect to existing Underground Facilities at or contiguous to the Site is based on information and data furnished to Owner or Engineer by the owners of such Underground Facilities, including Owner, or by others. Unless it is otherwise expressly provided in the Supplementary Conditions:
  1. Owner and Engineer shall not be responsible for the accuracy or completeness of any such information or data provided by others; and
  2. the cost of all of the following will be included in the Contract Price, and Contractor shall have full responsibility for:

- a. reviewing and checking all such information and data;
- b. locating all Underground Facilities shown or indicated in the Contract Documents;
- c. coordination of the Work with the owners of such Underground Facilities, including Owner, during construction; and
- d. the safety and protection of all such Underground Facilities and repairing any damage thereto resulting from the Work.

**B. *Not Shown or Indicated:***

1. If an Underground Facility is uncovered or revealed at or contiguous to the Site which was not shown or indicated, or not shown or indicated with reasonable accuracy in the Contract Documents, Contractor shall, promptly after becoming aware thereof and before further disturbing conditions affected thereby or performing any Work in connection therewith (except in an emergency as required by Paragraph 6.16.A), identify the owner of such Underground Facility and give written notice to that owner and to Owner and Engineer. Engineer will promptly review the Underground Facility and determine the extent, if any, to which a change is required in the Contract Documents to reflect and document the consequences of the existence or location of the Underground Facility. During such time, Contractor shall be responsible for the safety and protection of such Underground Facility.
2. If Engineer concludes that a change in the Contract Documents is required, a Work Change Directive or a Change Order will be issued to reflect and document such consequences. An equitable adjustment shall be made in the Contract Price or Contract Times, or both, to the extent that they are attributable to the existence or location of any Underground Facility that was not shown or indicated or not shown or indicated with reasonable accuracy in the Contract Documents and that Contractor did not know of and could not reasonably have been expected to be aware of or to have anticipated. If Owner and Contractor are unable to agree on entitlement to or on the amount or extent, if any, of any such adjustment in Contract Price or Contract Times, Owner or Contractor may make a Claim therefor as provided in Paragraph 10.05.

**4.05 *Reference Points***

- A. Owner shall provide engineering surveys to establish reference points for construction which in Engineer's judgment are necessary to enable Contractor to proceed with the Work. Contractor shall be responsible for laying out the Work, shall protect and preserve the established reference points and property monuments, and shall make no changes or relocations without the prior written approval of Owner. Contractor shall report to Engineer whenever any reference point or property monument is lost or destroyed or requires relocation because of necessary changes in grades or locations, and shall be responsible for the accurate replacement or relocation of such reference points or property monuments by professionally qualified personnel.

#### 4.06 *Hazardous Environmental Condition at Site*

- A. *Reports and Drawings:* The Supplementary Conditions identify those reports and drawings known to Owner relating to Hazardous Environmental Conditions that have been identified at the Site.
- B. *Limited Reliance by Contractor on Technical Data Authorized:* Contractor may rely upon the accuracy of the “technical data” contained in such reports and drawings, but such reports and drawings are not Contract Documents. Such “technical data” is identified in the Supplementary Conditions. Except for such reliance on such “technical data,” Contractor may not rely upon or make any claim against Owner or Engineer, or any of their officers, directors, members, partners, employees, agents, consultants, or subcontractors with respect to:
1. the completeness of such reports and drawings for Contractor’s purposes, including, but not limited to, any aspects of the means, methods, techniques, sequences and procedures of construction to be employed by Contractor and safety precautions and programs incident thereto; or
  2. other data, interpretations, opinions and information contained in such reports or shown or indicated in such drawings; or
  3. any Contractor interpretation of or conclusion drawn from any “technical data” or any such other data, interpretations, opinions or information.
- C. Contractor shall not be responsible for any Hazardous Environmental Condition uncovered or revealed at the Site which was not shown or indicated in Drawings or Specifications or identified in the Contract Documents to be within the scope of the Work. Contractor shall be responsible for a Hazardous Environmental Condition created with any materials brought to the Site by Contractor, Subcontractors, Suppliers, or anyone else for whom Contractor is responsible.
- D. If Contractor encounters a Hazardous Environmental Condition or if Contractor or anyone for whom Contractor is responsible creates a Hazardous Environmental Condition, Contractor shall immediately: (i) secure or otherwise isolate such condition; (ii) stop all Work in connection with such condition and in any area affected thereby (except in an emergency as required by Paragraph 6.16.A); and (iii) notify Owner and Engineer (and promptly thereafter confirm such notice in writing). Owner shall promptly consult with Engineer concerning the necessity for Owner to retain a qualified expert to evaluate such condition or take corrective action, if any. Promptly after consulting with Engineer, Owner shall take such actions as are necessary to permit Owner to timely obtain required permits and provide Contractor the written notice required by Paragraph 4.06.E.
- E. Contractor shall not be required to resume Work in connection with such condition or in any affected area until after Owner has obtained any required permits related thereto and delivered written notice to Contractor: (i) specifying that such condition and any affected area is or has been rendered safe for the resumption of Work; or (ii) specifying any special

conditions under which such Work may be resumed safely. If Owner and Contractor cannot agree as to entitlement to or on the amount or extent, if any, of any adjustment in Contract Price or Contract Times, or both, as a result of such Work stoppage or such special conditions under which Work is agreed to be resumed by Contractor, either party may make a Claim therefor as provided in Paragraph 10.05.

- F. If after receipt of such written notice Contractor does not agree to resume such Work based on a reasonable belief it is unsafe, or does not agree to resume such Work under such special conditions, then Owner may order the portion of the Work that is in the area affected by such condition to be deleted from the Work. If Owner and Contractor cannot agree as to entitlement to or on the amount or extent, if any, of an adjustment in Contract Price or Contract Times as a result of deleting such portion of the Work, then either party may make a Claim therefor as provided in Paragraph 10.05. Owner may have such deleted portion of the Work performed by Owner's own forces or others in accordance with Article 7.
- G. To the fullest extent permitted by Laws and Regulations, Owner shall indemnify and hold harmless Contractor, Subcontractors, and Engineer, and the officers, directors, members, partners, employees, agents, consultants, and subcontractors of each and any of them from and against all claims, costs, losses, and damages (including but not limited to all fees and charges of engineers, architects, attorneys, and other professionals and all court or arbitration or other dispute resolution costs) arising out of or relating to a Hazardous Environmental Condition, provided that such Hazardous Environmental Condition: (i) was not shown or indicated in the Drawings or Specifications or identified in the Contract Documents to be included within the scope of the Work, and (ii) was not created by Contractor or by anyone for whom Contractor is responsible. Nothing in this Paragraph 4.06.G shall obligate Owner to indemnify any individual or entity from and against the consequences of that individual's or entity's own negligence.
- H. To the fullest extent permitted by Laws and Regulations, Contractor shall indemnify and hold harmless Owner and Engineer, and the officers, directors, members, partners, employees, agents, consultants, and subcontractors of each and any of them from and against all claims, costs, losses, and damages (including but not limited to all fees and charges of engineers, architects, attorneys, and other professionals and all court or arbitration or other dispute resolution costs) arising out of or relating to a Hazardous Environmental Condition created by Contractor or by anyone for whom Contractor is responsible. Nothing in this Paragraph 4.06.H shall obligate Contractor to indemnify any individual or entity from and against the consequences of that individual's or entity's own negligence.
- I. The provisions of Paragraphs 4.02, 4.03, and 4.04 do not apply to a Hazardous Environmental Condition uncovered or revealed at the Site.

## ARTICLE 5 – BONDS AND INSURANCE

### 5.01 *Performance, Payment, and Other Bonds*

- A. Contractor shall furnish performance and payment bonds, each in an amount at least equal to the Contract Price as security for the faithful performance and payment of all of Contractor's obligations under the Contract Documents. These bonds shall remain in effect until one year after the date when final payment becomes due or until completion of the correction period specified in Paragraph 13.07, whichever is later, except as provided otherwise by Laws or Regulations or by the Contract Documents. Contractor shall also furnish such other bonds as are required by the Contract Documents.
- B. All bonds shall be in the form prescribed by the Contract Documents except as provided otherwise by Laws or Regulations, and shall be executed by such sureties as are named in the list of "Companies Holding Certificates of Authority as Acceptable Sureties on Federal Bonds and as Acceptable Reinsuring Companies" as published in Circular 570 (amended) by the Financial Management Service, Surety Bond Branch, U.S. Department of the Treasury. All bonds signed by an agent or attorney-in-fact must be accompanied by a certified copy of that individual's authority to bind the surety. The evidence of authority shall show that it is effective on the date the agent or attorney-in-fact signed each bond.
- C. If the surety on any bond furnished by Contractor is declared bankrupt or becomes insolvent or its right to do business is terminated in any state where any part of the Project is located or it ceases to meet the requirements of Paragraph 5.01.B, Contractor shall promptly notify Owner and Engineer and shall, within 20 days after the event giving rise to such notification, provide another bond and surety, both of which shall comply with the requirements of Paragraphs 5.01.B and 5.02.

### 5.02 *Licensed Sureties and Insurers*

- A. All bonds and insurance required by the Contract Documents to be purchased and maintained by Owner or Contractor shall be obtained from surety or insurance companies that are duly licensed or authorized in the jurisdiction in which the Project is located to issue bonds or insurance policies for the limits and coverages so required. Such surety and insurance companies shall also meet such additional requirements and qualifications as may be provided in the Supplementary Conditions.

### 5.03 *Certificates of Insurance*

- A. Contractor shall deliver to Owner, with copies to each additional insured and loss payee identified in the Supplementary Conditions, certificates of insurance (and other evidence of insurance requested by Owner or any other additional insured) which Contractor is required to purchase and maintain.
- B. Owner shall deliver to Contractor, with copies to each additional insured and loss payee identified in the Supplementary Conditions, certificates of insurance (and other evidence of

insurance requested by Contractor or any other additional insured) which Owner is required to purchase and maintain.

- C. Failure of Owner to demand such certificates or other evidence of Contractor's full compliance with these insurance requirements or failure of Owner to identify a deficiency in compliance from the evidence provided shall not be construed as a waiver of Contractor's obligation to maintain such insurance.
- D. Owner does not represent that insurance coverage and limits established in this Contract necessarily will be adequate to protect Contractor.
- E. The insurance and insurance limits required herein shall not be deemed as a limitation on Contractor's liability under the indemnities granted to Owner in the Contract Documents.

#### 5.04 *Contractor's Insurance*

- A. Contractor shall purchase and maintain such insurance as is appropriate for the Work being performed and as will provide protection from claims set forth below which may arise out of or result from Contractor's performance of the Work and Contractor's other obligations under the Contract Documents, whether it is to be performed by Contractor, any Subcontractor or Supplier, or by anyone directly or indirectly employed by any of them to perform any of the Work, or by anyone for whose acts any of them may be liable:
  - 1. claims under workers' compensation, disability benefits, and other similar employee benefit acts;
  - 2. claims for damages because of bodily injury, occupational sickness or disease, or death of Contractor's employees;
  - 3. claims for damages because of bodily injury, sickness or disease, or death of any person other than Contractor's employees;
  - 4. claims for damages insured by reasonably available personal injury liability coverage which are sustained:
    - a. by any person as a result of an offense directly or indirectly related to the employment of such person by Contractor, or
    - b. by any other person for any other reason;
  - 5. claims for damages, other than to the Work itself, because of injury to or destruction of tangible property wherever located, including loss of use resulting therefrom; and
  - 6. claims for damages because of bodily injury or death of any person or property damage arising out of the ownership, maintenance or use of any motor vehicle.
- B. The policies of insurance required by this Paragraph 5.04 shall:



1. with respect to insurance required by Paragraphs 5.04.A.3 through 5.04.A.6 inclusive, be written on an occurrence basis, include as additional insureds (subject to any customary exclusion regarding professional liability) Owner and Engineer, and any other individuals or entities identified in the Supplementary Conditions, all of whom shall be listed as additional insureds, and include coverage for the respective officers, directors, members, partners, employees, agents, consultants, and subcontractors of each and any of all such additional insureds, and the insurance afforded to these additional insureds shall provide primary coverage for all claims covered thereby;
2. include at least the specific coverages and be written for not less than the limits of liability provided in the Supplementary Conditions or required by Laws or Regulations, whichever is greater;
3. include contractual liability insurance covering Contractor's indemnity obligations under Paragraphs 6.11 and 6.20;
4. contain a provision or endorsement that the coverage afforded will not be canceled, materially changed or renewal refused until at least 30 days prior written notice has been given to Owner and Contractor and to each other additional insured identified in the Supplementary Conditions to whom a certificate of insurance has been issued (and the certificates of insurance furnished by the Contractor pursuant to Paragraph 5.03 will so provide);
5. remain in effect at least until final payment and at all times thereafter when Contractor may be correcting, removing, or replacing defective Work in accordance with Paragraph 13.07; and
6. include completed operations coverage:
  - a. Such insurance shall remain in effect for two years after final payment.
  - b. Contractor shall furnish Owner and each other additional insured identified in the Supplementary Conditions, to whom a certificate of insurance has been issued, evidence satisfactory to Owner and any such additional insured of continuation of such insurance at final payment and one year thereafter.

#### 5.05 *Owner's Liability Insurance*

- A. In addition to the insurance required to be provided by Contractor under Paragraph 5.04, Owner, at Owner's option, may purchase and maintain at Owner's expense Owner's own liability insurance as will protect Owner against claims which may arise from operations under the Contract Documents.

#### 5.06 *Property Insurance*

- A. Unless otherwise provided in the Supplementary Conditions, Owner shall purchase and maintain property insurance upon the Work at the Site in the amount of the full replacement

cost thereof (subject to such deductible amounts as may be provided in the Supplementary Conditions or required by Laws and Regulations). This insurance shall:

1. include the interests of Owner, Contractor, Subcontractors, and Engineer, and any other individuals or entities identified in the Supplementary Conditions, and the officers, directors, members, partners, employees, agents, consultants, and subcontractors of each and any of them, each of whom is deemed to have an insurable interest and shall be listed as a loss payee;
  2. be written on a Builder's Risk "all-risk" policy form that shall at least include insurance for physical loss or damage to the Work, temporary buildings, falsework, and materials and equipment in transit, and shall insure against at least the following perils or causes of loss: fire, lightning, extended coverage, theft, vandalism and malicious mischief, earthquake, collapse, debris removal, demolition occasioned by enforcement of Laws and Regulations, water damage (other than that caused by flood), and such other perils or causes of loss as may be specifically required by the Supplementary Conditions.
  3. include expenses incurred in the repair or replacement of any insured property (including but not limited to fees and charges of engineers and architects);
  4. cover materials and equipment stored at the Site or at another location that was agreed to in writing by Owner prior to being incorporated in the Work, provided that such materials and equipment have been included in an Application for Payment recommended by Engineer;
  5. allow for partial utilization of the Work by Owner;
  6. include testing and startup; and
  7. be maintained in effect until final payment is made unless otherwise agreed to in writing by Owner, Contractor, and Engineer with 30 days written notice to each other loss payee to whom a certificate of insurance has been issued.
- B. Owner shall purchase and maintain such equipment breakdown insurance or additional property insurance as may be required by the Supplementary Conditions or Laws and Regulations which will include the interests of Owner, Contractor, Subcontractors, and Engineer, and any other individuals or entities identified in the Supplementary Conditions, and the officers, directors, members, partners, employees, agents, consultants and subcontractors of each and any of them, each of whom is deemed to have an insurable interest and shall be listed as a loss payee.
- C. All the policies of insurance (and the certificates or other evidence thereof) required to be purchased and maintained in accordance with this Paragraph 5.06 will contain a provision or endorsement that the coverage afforded will not be canceled or materially changed or renewal refused until at least 30 days prior written notice has been given to Owner and Contractor and to each other loss payee to whom a certificate of insurance has been issued and will contain waiver provisions in accordance with Paragraph 5.07.

- D. Owner shall not be responsible for purchasing and maintaining any property insurance specified in this Paragraph 5.06 to protect the interests of Contractor, Subcontractors, or others in the Work to the extent of any deductible amounts that are identified in the Supplementary Conditions. The risk of loss within such identified deductible amount will be borne by Contractor, Subcontractors, or others suffering any such loss, and if any of them wishes property insurance coverage within the limits of such amounts, each may purchase and maintain it at the purchaser's own expense.
- E. If Contractor requests in writing that other special insurance be included in the property insurance policies provided under this Paragraph 5.06, Owner shall, if possible, include such insurance, and the cost thereof will be charged to Contractor by appropriate Change Order. Prior to commencement of the Work at the Site, Owner shall in writing advise Contractor whether or not such other insurance has been procured by Owner.

#### 5.07 *Waiver of Rights*

- A. Owner and Contractor intend that all policies purchased in accordance with Paragraph 5.06 will protect Owner, Contractor, Subcontractors, and Engineer, and all other individuals or entities identified in the Supplementary Conditions as loss payees (and the officers, directors, members, partners, employees, agents, consultants, and subcontractors of each and any of them) in such policies and will provide primary coverage for all losses and damages caused by the perils or causes of loss covered thereby. All such policies shall contain provisions to the effect that in the event of payment of any loss or damage the insurers will have no rights of recovery against any of the insureds or loss payees thereunder. Owner and Contractor waive all rights against each other and their respective officers, directors, members, partners, employees, agents, consultants and subcontractors of each and any of them for all losses and damages caused by, arising out of or resulting from any of the perils or causes of loss covered by such policies and any other property insurance applicable to the Work; and, in addition, waive all such rights against Subcontractors and Engineer, and all other individuals or entities identified in the Supplementary Conditions as loss payees (and the officers, directors, members, partners, employees, agents, consultants, and subcontractors of each and any of them) under such policies for losses and damages so caused. None of the above waivers shall extend to the rights that any party making such waiver may have to the proceeds of insurance held by Owner as trustee or otherwise payable under any policy so issued.
- B. Owner waives all rights against Contractor, Subcontractors, and Engineer, and the officers, directors, members, partners, employees, agents, consultants and subcontractors of each and any of them for:
  - 1. loss due to business interruption, loss of use, or other consequential loss extending beyond direct physical loss or damage to Owner's property or the Work caused by, arising out of, or resulting from fire or other perils whether or not insured by Owner; and
  - 2. loss or damage to the completed Project or part thereof caused by, arising out of, or resulting from fire or other insured peril or cause of loss covered by any property insurance maintained on the completed Project or part thereof by Owner during partial utilization

pursuant to Paragraph 14.05, after Substantial Completion pursuant to Paragraph 14.04, or after final payment pursuant to Paragraph 14.07.

- C. Any insurance policy maintained by Owner covering any loss, damage or consequential loss referred to in Paragraph 5.07.B shall contain provisions to the effect that in the event of payment of any such loss, damage, or consequential loss, the insurers will have no rights of recovery against Contractor, Subcontractors, or Engineer, and the officers, directors, members, partners, employees, agents, consultants and subcontractors of each and any of them.

5.08 *Receipt and Application of Insurance Proceeds*

- A. Any insured loss under the policies of insurance required by Paragraph 5.06 will be adjusted with Owner and made payable to Owner as fiduciary for the loss payees, as their interests may appear, subject to the requirements of any applicable mortgage clause and of Paragraph 5.08.B. Owner shall deposit in a separate account any money so received and shall distribute it in accordance with such agreement as the parties in interest may reach. If no other special agreement is reached, the damaged Work shall be repaired or replaced, the moneys so received applied on account thereof, and the Work and the cost thereof covered by an appropriate Change Order.
- B. Owner as fiduciary shall have power to adjust and settle any loss with the insurers unless one of the parties in interest shall object in writing within 15 days after the occurrence of loss to Owner's exercise of this power. If such objection be made, Owner as fiduciary shall make settlement with the insurers in accordance with such agreement as the parties in interest may reach. If no such agreement among the parties in interest is reached, Owner as fiduciary shall adjust and settle the loss with the insurers and, if required in writing by any party in interest, Owner as fiduciary shall give bond for the proper performance of such duties.

5.09 *Acceptance of Bonds and Insurance; Option to Replace*

- A. If either Owner or Contractor has any objection to the coverage afforded by or other provisions of the bonds or insurance required to be purchased and maintained by the other party in accordance with Article 5 on the basis of non-conformance with the Contract Documents, the objecting party shall so notify the other party in writing within 10 days after receipt of the certificates (or other evidence requested) required by Paragraph 2.01.B. Owner and Contractor shall each provide to the other such additional information in respect of insurance provided as the other may reasonably request. If either party does not purchase or maintain all of the bonds and insurance required of such party by the Contract Documents, such party shall notify the other party in writing of such failure to purchase prior to the start of the Work, or of such failure to maintain prior to any change in the required coverage. Without prejudice to any other right or remedy, the other party may elect to obtain equivalent bonds or insurance to protect such other party's interests at the expense of the party who was required to provide such coverage, and a Change Order shall be issued to adjust the Contract Price accordingly.

#### 5.10 *Partial Utilization, Acknowledgment of Property Insurer*

- A. If Owner finds it necessary to occupy or use a portion or portions of the Work prior to Substantial Completion of all the Work as provided in Paragraph 14.05, no such use or occupancy shall commence before the insurers providing the property insurance pursuant to Paragraph 5.06 have acknowledged notice thereof and in writing effected any changes in coverage necessitated thereby. The insurers providing the property insurance shall consent by endorsement on the policy or policies, but the property insurance shall not be canceled or permitted to lapse on account of any such partial use or occupancy.

### **ARTICLE 6 – CONTRACTOR’S RESPONSIBILITIES**

#### 6.01 *Supervision and Superintendence*

- A. Contractor shall supervise, inspect, and direct the Work competently and efficiently, devoting such attention thereto and applying such skills and expertise as may be necessary to perform the Work in accordance with the Contract Documents. Contractor shall be solely responsible for the means, methods, techniques, sequences, and procedures of construction. Contractor shall not be responsible for the negligence of Owner or Engineer in the design or specification of a specific means, method, technique, sequence, or procedure of construction which is shown or indicated in and expressly required by the Contract Documents.
- B. At all times during the progress of the Work, Contractor shall assign a competent resident superintendent who shall not be replaced without written notice to Owner and Engineer except under extraordinary circumstances.

#### 6.02 *Labor; Working Hours*

- A. Contractor shall provide competent, suitably qualified personnel to survey and lay out the Work and perform construction as required by the Contract Documents. Contractor shall at all times maintain good discipline and order at the Site.
- B. Except as otherwise required for the safety or protection of persons or the Work or property at the Site or adjacent thereto, and except as otherwise stated in the Contract Documents, all Work at the Site shall be performed during regular working hours. Contractor will not permit the performance of Work on a Saturday, Sunday, or any legal holiday without Owner’s written consent (which will not be unreasonably withheld) given after prior written notice to Engineer.

#### 6.03 *Services, Materials, and Equipment*

- A. Unless otherwise specified in the Contract Documents, Contractor shall provide and assume full responsibility for all services, materials, equipment, labor, transportation, construction equipment and machinery, tools, appliances, fuel, power, light, heat, telephone, water, sanitary facilities, temporary facilities, and all other facilities and incidentals necessary for the performance, testing, start-up, and completion of the Work.

- B. All materials and equipment incorporated into the Work shall be as specified or, if not specified, shall be of good quality and new, except as otherwise provided in the Contract Documents. All special warranties and guarantees required by the Specifications shall expressly run to the benefit of Owner. If required by Engineer, Contractor shall furnish satisfactory evidence (including reports of required tests) as to the source, kind, and quality of materials and equipment.
- C. All materials and equipment shall be stored, applied, installed, connected, erected, protected, used, cleaned, and conditioned in accordance with instructions of the applicable Supplier, except as otherwise may be provided in the Contract Documents.

#### 6.04 *Progress Schedule*

- A. Contractor shall adhere to the Progress Schedule established in accordance with Paragraph 2.07 as it may be adjusted from time to time as provided below.
  - 1. Contractor shall submit to Engineer for acceptance (to the extent indicated in Paragraph 2.07) proposed adjustments in the Progress Schedule that will not result in changing the Contract Times. Such adjustments will comply with any provisions of the General Requirements applicable thereto.
  - 2. Proposed adjustments in the Progress Schedule that will change the Contract Times shall be submitted in accordance with the requirements of Article 12. Adjustments in Contract Times may only be made by a Change Order.

#### 6.05 *Substitutes and "Or-Equals"*

- A. Whenever an item of material or equipment is specified or described in the Contract Documents by using the name of a proprietary item or the name of a particular Supplier, the specification or description is intended to establish the type, function, appearance, and quality required. Unless the specification or description contains or is followed by words reading that no like, equivalent, or "or-equal" item or no substitution is permitted, other items of material or equipment or material or equipment of other Suppliers may be submitted to Engineer for review under the circumstances described below.
  - 1. *"Or-Equal" Items:* If in Engineer's sole discretion an item of material or equipment proposed by Contractor is functionally equal to that named and sufficiently similar so that no change in related Work will be required, it may be considered by Engineer as an "or-equal" item, in which case review and approval of the proposed item may, in Engineer's sole discretion, be accomplished without compliance with some or all of the requirements for approval of proposed substitute items. For the purposes of this Paragraph 6.05.A.1, a proposed item of material or equipment will be considered functionally equal to an item so named if:
    - a. in the exercise of reasonable judgment Engineer determines that:

- 1) it is at least equal in materials of construction, quality, durability, appearance, strength, and design characteristics;
  - 2) it will reliably perform at least equally well the function and achieve the results imposed by the design concept of the completed Project as a functioning whole; and
  - 3) it has a proven record of performance and availability of responsive service.
- b. Contractor certifies that, if approved and incorporated into the Work:
- 1) there will be no increase in cost to the Owner or increase in Contract Times; and
  - 2) it will conform substantially to the detailed requirements of the item named in the Contract Documents.

2. *Substitute Items:*

- a. If in Engineer's sole discretion an item of material or equipment proposed by Contractor does not qualify as an "or-equal" item under Paragraph 6.05.A.1, it will be considered a proposed substitute item.
- b. Contractor shall submit sufficient information as provided below to allow Engineer to determine if the item of material or equipment proposed is essentially equivalent to that named and an acceptable substitute therefor. Requests for review of proposed substitute items of material or equipment will not be accepted by Engineer from anyone other than Contractor.
- c. The requirements for review by Engineer will be as set forth in Paragraph 6.05.A.2.d, as supplemented by the General Requirements, and as Engineer may decide is appropriate under the circumstances.
- d. Contractor shall make written application to Engineer for review of a proposed substitute item of material or equipment that Contractor seeks to furnish or use. The application:
  - 1) shall certify that the proposed substitute item will:
    - a) perform adequately the functions and achieve the results called for by the general design,
    - b) be similar in substance to that specified, and
    - c) be suited to the same use as that specified;
  - 2) will state:

- a) the extent, if any, to which the use of the proposed substitute item will prejudice Contractor's achievement of Substantial Completion on time,
  - b) whether use of the proposed substitute item in the Work will require a change in any of the Contract Documents (or in the provisions of any other direct contract with Owner for other work on the Project) to adapt the design to the proposed substitute item, and
  - c) whether incorporation or use of the proposed substitute item in connection with the Work is subject to payment of any license fee or royalty;
- 3) will identify:
- a) all variations of the proposed substitute item from that specified, and
  - b) available engineering, sales, maintenance, repair, and replacement services; and
- 4) shall contain an itemized estimate of all costs or credits that will result directly or indirectly from use of such substitute item, including costs of redesign and claims of other contractors affected by any resulting change.
- B. *Substitute Construction Methods or Procedures:* If a specific means, method, technique, sequence, or procedure of construction is expressly required by the Contract Documents, Contractor may furnish or utilize a substitute means, method, technique, sequence, or procedure of construction approved by Engineer. Contractor shall submit sufficient information to allow Engineer, in Engineer's sole discretion, to determine that the substitute proposed is equivalent to that expressly called for by the Contract Documents. The requirements for review by Engineer will be similar to those provided in Paragraph 6.05.A.2.
- C. *Engineer's Evaluation:* Engineer will be allowed a reasonable time within which to evaluate each proposal or submittal made pursuant to Paragraphs 6.05.A and 6.05.B. Engineer may require Contractor to furnish additional data about the proposed substitute item. Engineer will be the sole judge of acceptability. No "or equal" or substitute will be ordered, installed or utilized until Engineer's review is complete, which will be evidenced by a Change Order in the case of a substitute and an approved Shop Drawing for an "or equal." Engineer will advise Contractor in writing of any negative determination.
- D. *Special Guarantee:* Owner may require Contractor to furnish at Contractor's expense a special performance guarantee or other surety with respect to any substitute.
- E. *Engineer's Cost Reimbursement:* Engineer will record Engineer's costs in evaluating a substitute proposed or submitted by Contractor pursuant to Paragraphs 6.05.A.2 and 6.05.B. Whether or not Engineer approves a substitute so proposed or submitted by Contractor, Contractor shall reimburse Owner for the reasonable charges of Engineer for evaluating each such proposed substitute. Contractor shall also reimburse Owner for the reasonable charges of



Engineer for making changes in the Contract Documents (or in the provisions of any other direct contract with Owner) resulting from the acceptance of each proposed substitute.

- F. *Contractor's Expense*: Contractor shall provide all data in support of any proposed substitute or "or-equal" at Contractor's expense.

#### 6.06 *Concerning Subcontractors, Suppliers, and Others*

- A. Contractor shall not employ any Subcontractor, Supplier, or other individual or entity (including those acceptable to Owner as indicated in Paragraph 6.06.B), whether initially or as a replacement, against whom Owner may have reasonable objection. Contractor shall not be required to employ any Subcontractor, Supplier, or other individual or entity to furnish or perform any of the Work against whom Contractor has reasonable objection.
- B. If the Supplementary Conditions require the identity of certain Subcontractors, Suppliers, or other individuals or entities to be submitted to Owner in advance for acceptance by Owner by a specified date prior to the Effective Date of the Agreement, and if Contractor has submitted a list thereof in accordance with the Supplementary Conditions, Owner's acceptance (either in writing or by failing to make written objection thereto by the date indicated for acceptance or objection in the Bidding Documents or the Contract Documents) of any such Subcontractor, Supplier, or other individual or entity so identified may be revoked on the basis of reasonable objection after due investigation. Contractor shall submit an acceptable replacement for the rejected Subcontractor, Supplier, or other individual or entity, and the Contract Price will be adjusted by the difference in the cost occasioned by such replacement, and an appropriate Change Order will be issued. No acceptance by Owner of any such Subcontractor, Supplier, or other individual or entity, whether initially or as a replacement, shall constitute a waiver of any right of Owner or Engineer to reject defective Work.
- C. Contractor shall be fully responsible to Owner and Engineer for all acts and omissions of the Subcontractors, Suppliers, and other individuals or entities performing or furnishing any of the Work just as Contractor is responsible for Contractor's own acts and omissions. Nothing in the Contract Documents:
1. shall create for the benefit of any such Subcontractor, Supplier, or other individual or entity any contractual relationship between Owner or Engineer and any such Subcontractor, Supplier or other individual or entity; nor
  2. shall create any obligation on the part of Owner or Engineer to pay or to see to the payment of any moneys due any such Subcontractor, Supplier, or other individual or entity except as may otherwise be required by Laws and Regulations.
- D. Contractor shall be solely responsible for scheduling and coordinating the Work of Subcontractors, Suppliers, and other individuals or entities performing or furnishing any of the Work under a direct or indirect contract with Contractor.
- E. Contractor shall require all Subcontractors, Suppliers, and such other individuals or entities performing or furnishing any of the Work to communicate with Engineer through Contractor.

- F. The divisions and sections of the Specifications and the identifications of any Drawings shall not control Contractor in dividing the Work among Subcontractors or Suppliers or delineating the Work to be performed by any specific trade.
- G. All Work performed for Contractor by a Subcontractor or Supplier will be pursuant to an appropriate agreement between Contractor and the Subcontractor or Supplier which specifically binds the Subcontractor or Supplier to the applicable terms and conditions of the Contract Documents for the benefit of Owner and Engineer. Whenever any such agreement is with a Subcontractor or Supplier who is listed as a loss payee on the property insurance provided in Paragraph 5.06, the agreement between the Contractor and the Subcontractor or Supplier will contain provisions whereby the Subcontractor or Supplier waives all rights against Owner, Contractor, Engineer, and all other individuals or entities identified in the Supplementary Conditions to be listed as insureds or loss payees (and the officers, directors, members, partners, employees, agents, consultants, and subcontractors of each and any of them) for all losses and damages caused by, arising out of, relating to, or resulting from any of the perils or causes of loss covered by such policies and any other property insurance applicable to the Work. If the insurers on any such policies require separate waiver forms to be signed by any Subcontractor or Supplier, Contractor will obtain the same.

#### 6.07 *Patent Fees and Royalties*

- A. Contractor shall pay all license fees and royalties and assume all costs incident to the use in the performance of the Work or the incorporation in the Work of any invention, design, process, product, or device which is the subject of patent rights or copyrights held by others. If a particular invention, design, process, product, or device is specified in the Contract Documents for use in the performance of the Work and if, to the actual knowledge of Owner or Engineer, its use is subject to patent rights or copyrights calling for the payment of any license fee or royalty to others, the existence of such rights shall be disclosed by Owner in the Contract Documents.
- B. To the fullest extent permitted by Laws and Regulations, Owner shall indemnify and hold harmless Contractor, and its officers, directors, members, partners, employees, agents, consultants, and subcontractors from and against all claims, costs, losses, and damages (including but not limited to all fees and charges of engineers, architects, attorneys, and other professionals, and all court or arbitration or other dispute resolution costs) arising out of or relating to any infringement of patent rights or copyrights incident to the use in the performance of the Work or resulting from the incorporation in the Work of any invention, design, process, product, or device specified in the Contract Documents, but not identified as being subject to payment of any license fee or royalty to others required by patent rights or copyrights.
- C. To the fullest extent permitted by Laws and Regulations, Contractor shall indemnify and hold harmless Owner and Engineer, and the officers, directors, members, partners, employees, agents, consultants and subcontractors of each and any of them from and against all claims, costs, losses, and damages (including but not limited to all fees and charges of engineers, architects, attorneys, and other professionals and all court or arbitration or other dispute

resolution costs) arising out of or relating to any infringement of patent rights or copyrights incident to the use in the performance of the Work or resulting from the incorporation in the Work of any invention, design, process, product, or device not specified in the Contract Documents.

#### 6.08 *Permits*

- A. Unless otherwise provided in the Supplementary Conditions, Contractor shall obtain and pay for all construction permits and licenses. Owner shall assist Contractor, when necessary, in obtaining such permits and licenses. Contractor shall pay all governmental charges and inspection fees necessary for the prosecution of the Work which are applicable at the time of opening of Bids, or, if there are no Bids, on the Effective Date of the Agreement. Owner shall pay all charges of utility owners for connections for providing permanent service to the Work.

#### 6.09 *Laws and Regulations*

- A. Contractor shall give all notices required by and shall comply with all Laws and Regulations applicable to the performance of the Work. Except where otherwise expressly required by applicable Laws and Regulations, neither Owner nor Engineer shall be responsible for monitoring Contractor's compliance with any Laws or Regulations.
- B. If Contractor performs any Work knowing or having reason to know that it is contrary to Laws or Regulations, Contractor shall bear all claims, costs, losses, and damages (including but not limited to all fees and charges of engineers, architects, attorneys, and other professionals and all court or arbitration or other dispute resolution costs) arising out of or relating to such Work. However, it shall not be Contractor's responsibility to make certain that the Specifications and Drawings are in accordance with Laws and Regulations, but this shall not relieve Contractor of Contractor's obligations under Paragraph 3.03.
- C. Changes in Laws or Regulations not known at the time of opening of Bids (or, on the Effective Date of the Agreement if there were no Bids) having an effect on the cost or time of performance of the Work shall be the subject of an adjustment in Contract Price or Contract Times. If Owner and Contractor are unable to agree on entitlement to or on the amount or extent, if any, of any such adjustment, a Claim may be made therefor as provided in Paragraph 10.05.

#### 6.10 *Taxes*

- A. Contractor shall pay all sales, consumer, use, and other similar taxes required to be paid by Contractor in accordance with the Laws and Regulations of the place of the Project which are applicable during the performance of the Work.

#### 6.11 *Use of Site and Other Areas*

- A. *Limitation on Use of Site and Other Areas:*

1. Contractor shall confine construction equipment, the storage of materials and equipment, and the operations of workers to the Site and other areas permitted by Laws and Regulations, and shall not unreasonably encumber the Site and other areas with construction equipment or other materials or equipment. Contractor shall assume full responsibility for any damage to any such land or area, or to the owner or occupant thereof, or of any adjacent land or areas resulting from the performance of the Work.
  2. Should any claim be made by any such owner or occupant because of the performance of the Work, Contractor shall promptly settle with such other party by negotiation or otherwise resolve the claim by arbitration or other dispute resolution proceeding or at law.
  3. To the fullest extent permitted by Laws and Regulations, Contractor shall indemnify and hold harmless Owner and Engineer, and the officers, directors, members, partners, employees, agents, consultants and subcontractors of each and any of them from and against all claims, costs, losses, and damages (including but not limited to all fees and charges of engineers, architects, attorneys, and other professionals and all court or arbitration or other dispute resolution costs) arising out of or relating to any claim or action, legal or equitable, brought by any such owner or occupant against Owner, Engineer, or any other party indemnified hereunder to the extent caused by or based upon Contractor's performance of the Work.
- B. *Removal of Debris During Performance of the Work:* During the progress of the Work Contractor shall keep the Site and other areas free from accumulations of waste materials, rubbish, and other debris. Removal and disposal of such waste materials, rubbish, and other debris shall conform to applicable Laws and Regulations.
- C. *Cleaning:* Prior to Substantial Completion of the Work Contractor shall clean the Site and the Work and make it ready for utilization by Owner. At the completion of the Work Contractor shall remove from the Site all tools, appliances, construction equipment and machinery, and surplus materials and shall restore to original condition all property not designated for alteration by the Contract Documents.
- D. *Loading Structures:* Contractor shall not load nor permit any part of any structure to be loaded in any manner that will endanger the structure, nor shall Contractor subject any part of the Work or adjacent property to stresses or pressures that will endanger it.

#### 6.12 *Record Documents*

- A. Contractor shall maintain in a safe place at the Site one record copy of all Drawings, Specifications, Addenda, Change Orders, Work Change Directives, Field Orders, and written interpretations and clarifications in good order and annotated to show changes made during construction. These record documents together with all approved Samples and a counterpart of all approved Shop Drawings will be available to Engineer for reference. Upon completion of the Work, these record documents, Samples, and Shop Drawings will be delivered to Engineer for Owner.

### 6.13 *Safety and Protection*

- A. Contractor shall be solely responsible for initiating, maintaining and supervising all safety precautions and programs in connection with the Work. Such responsibility does not relieve Subcontractors of their responsibility for the safety of persons or property in the performance of their work, nor for compliance with applicable safety Laws and Regulations. Contractor shall take all necessary precautions for the safety of, and shall provide the necessary protection to prevent damage, injury or loss to:
1. all persons on the Site or who may be affected by the Work;
  2. all the Work and materials and equipment to be incorporated therein, whether in storage on or off the Site; and
  3. other property at the Site or adjacent thereto, including trees, shrubs, lawns, walks, pavements, roadways, structures, utilities, and Underground Facilities not designated for removal, relocation, or replacement in the course of construction.
- B. Contractor shall comply with all applicable Laws and Regulations relating to the safety of persons or property, or to the protection of persons or property from damage, injury, or loss; and shall erect and maintain all necessary safeguards for such safety and protection. Contractor shall notify owners of adjacent property and of Underground Facilities and other utility owners when prosecution of the Work may affect them, and shall cooperate with them in the protection, removal, relocation, and replacement of their property.
- C. Contractor shall comply with the applicable requirements of Owner's safety programs, if any. The Supplementary Conditions identify any Owner's safety programs that are applicable to the Work.
- D. Contractor shall inform Owner and Engineer of the specific requirements of Contractor's safety program with which Owner's and Engineer's employees and representatives must comply while at the Site.
- E. All damage, injury, or loss to any property referred to in Paragraph 6.13.A.2 or 6.13.A.3 caused, directly or indirectly, in whole or in part, by Contractor, any Subcontractor, Supplier, or any other individual or entity directly or indirectly employed by any of them to perform any of the Work, or anyone for whose acts any of them may be liable, shall be remedied by Contractor (except damage or loss attributable to the fault of Drawings or Specifications or to the acts or omissions of Owner or Engineer or anyone employed by any of them, or anyone for whose acts any of them may be liable, and not attributable, directly or indirectly, in whole or in part, to the fault or negligence of Contractor or any Subcontractor, Supplier, or other individual or entity directly or indirectly employed by any of them).
- F. Contractor's duties and responsibilities for safety and for protection of the Work shall continue until such time as all the Work is completed and Engineer has issued a notice to Owner and Contractor in accordance with Paragraph 14.07.B that the Work is acceptable (except as otherwise expressly provided in connection with Substantial Completion).

#### 6.14 *Safety Representative*

- A. Contractor shall designate a qualified and experienced safety representative at the Site whose duties and responsibilities shall be the prevention of accidents and the maintaining and supervising of safety precautions and programs.

#### 6.15 *Hazard Communication Programs*

- A. Contractor shall be responsible for coordinating any exchange of material safety data sheets or other hazard communication information required to be made available to or exchanged between or among employers at the Site in accordance with Laws or Regulations.

#### 6.16 *Emergencies*

- A. In emergencies affecting the safety or protection of persons or the Work or property at the Site or adjacent thereto, Contractor is obligated to act to prevent threatened damage, injury, or loss. Contractor shall give Engineer prompt written notice if Contractor believes that any significant changes in the Work or variations from the Contract Documents have been caused thereby or are required as a result thereof. If Engineer determines that a change in the Contract Documents is required because of the action taken by Contractor in response to such an emergency, a Work Change Directive or Change Order will be issued.

#### 6.17 *Shop Drawings and Samples*

- A. Contractor shall submit Shop Drawings and Samples to Engineer for review and approval in accordance with the accepted Schedule of Submittals (as required by Paragraph 2.07). Each submittal will be identified as Engineer may require.

##### 1. *Shop Drawings:*

- a. Submit number of copies specified in the General Requirements.
- b. Data shown on the Shop Drawings will be complete with respect to quantities, dimensions, specified performance and design criteria, materials, and similar data to show Engineer the services, materials, and equipment Contractor proposes to provide and to enable Engineer to review the information for the limited purposes required by Paragraph 6.17.D.

##### 2. *Samples:*

- a. Submit number of Samples specified in the Specifications.
- b. Clearly identify each Sample as to material, Supplier, pertinent data such as catalog numbers, the use for which intended and other data as Engineer may require to enable Engineer to review the submittal for the limited purposes required by Paragraph 6.17.D.

B. Where a Shop Drawing or Sample is required by the Contract Documents or the Schedule of Submittals, any related Work performed prior to Engineer's review and approval of the pertinent submittal will be at the sole expense and responsibility of Contractor.

C. *Submittal Procedures:*

1. Before submitting each Shop Drawing or Sample, Contractor shall have:
  - a. reviewed and coordinated each Shop Drawing or Sample with other Shop Drawings and Samples and with the requirements of the Work and the Contract Documents;
  - b. determined and verified all field measurements, quantities, dimensions, specified performance and design criteria, installation requirements, materials, catalog numbers, and similar information with respect thereto;
  - c. determined and verified the suitability of all materials offered with respect to the indicated application, fabrication, shipping, handling, storage, assembly, and installation pertaining to the performance of the Work; and
  - d. determined and verified all information relative to Contractor's responsibilities for means, methods, techniques, sequences, and procedures of construction, and safety precautions and programs incident thereto.
2. Each submittal shall bear a stamp or specific written certification that Contractor has satisfied Contractor's obligations under the Contract Documents with respect to Contractor's review and approval of that submittal.
3. With each submittal, Contractor shall give Engineer specific written notice of any variations that the Shop Drawing or Sample may have from the requirements of the Contract Documents. This notice shall be both a written communication separate from the Shop Drawings or Sample submittal; and, in addition, by a specific notation made on each Shop Drawing or Sample submitted to Engineer for review and approval of each such variation.

D. *Engineer's Review:*

1. Engineer will provide timely review of Shop Drawings and Samples in accordance with the Schedule of Submittals acceptable to Engineer. Engineer's review and approval will be only to determine if the items covered by the submittals will, after installation or incorporation in the Work, conform to the information given in the Contract Documents and be compatible with the design concept of the completed Project as a functioning whole as indicated by the Contract Documents.
2. Engineer's review and approval will not extend to means, methods, techniques, sequences, or procedures of construction (except where a particular means, method, technique, sequence, or procedure of construction is specifically and expressly called for by the Contract Documents) or to safety precautions or programs incident thereto. The review

and approval of a separate item as such will not indicate approval of the assembly in which the item functions.

3. Engineer's review and approval shall not relieve Contractor from responsibility for any variation from the requirements of the Contract Documents unless Contractor has complied with the requirements of Paragraph 6.17.C.3 and Engineer has given written approval of each such variation by specific written notation thereof incorporated in or accompanying the Shop Drawing or Sample. Engineer's review and approval shall not relieve Contractor from responsibility for complying with the requirements of Paragraph 6.17.C.1.

E. *Resubmittal Procedures:*

1. Contractor shall make corrections required by Engineer and shall return the required number of corrected copies of Shop Drawings and submit, as required, new Samples for review and approval. Contractor shall direct specific attention in writing to revisions other than the corrections called for by Engineer on previous submittals.

6.18 *Continuing the Work*

- A. Contractor shall carry on the Work and adhere to the Progress Schedule during all disputes or disagreements with Owner. No Work shall be delayed or postponed pending resolution of any disputes or disagreements, except as permitted by Paragraph 15.04 or as Owner and Contractor may otherwise agree in writing.

6.19 *Contractor's General Warranty and Guarantee*

- A. Contractor warrants and guarantees to Owner that all Work will be in accordance with the Contract Documents and will not be defective. Engineer and its officers, directors, members, partners, employees, agents, consultants, and subcontractors shall be entitled to rely on representation of Contractor's warranty and guarantee.
- B. Contractor's warranty and guarantee hereunder excludes defects or damage caused by:
  1. abuse, modification, or improper maintenance or operation by persons other than Contractor, Subcontractors, Suppliers, or any other individual or entity for whom Contractor is responsible; or
  2. normal wear and tear under normal usage.
- C. Contractor's obligation to perform and complete the Work in accordance with the Contract Documents shall be absolute. None of the following will constitute an acceptance of Work that is not in accordance with the Contract Documents or a release of Contractor's obligation to perform the Work in accordance with the Contract Documents:
  1. observations by Engineer;



2. recommendation by Engineer or payment by Owner of any progress or final payment;
3. the issuance of a certificate of Substantial Completion by Engineer or any payment related thereto by Owner;
4. use or occupancy of the Work or any part thereof by Owner;
5. any review and approval of a Shop Drawing or Sample submittal or the issuance of a notice of acceptability by Engineer;
6. any inspection, test, or approval by others; or
7. any correction of defective Work by Owner.

#### 6.20 *Indemnification*

- A. To the fullest extent permitted by Laws and Regulations, Contractor shall indemnify and hold harmless Owner and Engineer, and the officers, directors, members, partners, employees, agents, consultants and subcontractors of each and any of them from and against all claims, costs, losses, and damages (including but not limited to all fees and charges of engineers, architects, attorneys, and other professionals and all court or arbitration or other dispute resolution costs) arising out of or relating to the performance of the Work, provided that any such claim, cost, loss, or damage is attributable to bodily injury, sickness, disease, or death, or to injury to or destruction of tangible property (other than the Work itself), including the loss of use resulting therefrom but only to the extent caused by any negligent act or omission of Contractor, any Subcontractor, any Supplier, or any individual or entity directly or indirectly employed by any of them to perform any of the Work or anyone for whose acts any of them may be liable .
- B. In any and all claims against Owner or Engineer or any of their officers, directors, members, partners, employees, agents, consultants, or subcontractors by any employee (or the survivor or personal representative of such employee) of Contractor, any Subcontractor, any Supplier, or any individual or entity directly or indirectly employed by any of them to perform any of the Work, or anyone for whose acts any of them may be liable, the indemnification obligation under Paragraph 6.20.A shall not be limited in any way by any limitation on the amount or type of damages, compensation, or benefits payable by or for Contractor or any such Subcontractor, Supplier, or other individual or entity under workers' compensation acts, disability benefit acts, or other employee benefit acts.
- C. The indemnification obligations of Contractor under Paragraph 6.20.A shall not extend to the liability of Engineer and Engineer's officers, directors, members, partners, employees, agents, consultants and subcontractors arising out of:
  1. the preparation or approval of, or the failure to prepare or approve maps, Drawings, opinions, reports, surveys, Change Orders, designs, or Specifications; or

2. giving directions or instructions, or failing to give them, if that is the primary cause of the injury or damage.

#### 6.21 *Delegation of Professional Design Services*

- A. Contractor will not be required to provide professional design services unless such services are specifically required by the Contract Documents for a portion of the Work or unless such services are required to carry out Contractor's responsibilities for construction means, methods, techniques, sequences and procedures. Contractor shall not be required to provide professional services in violation of applicable law.
- B. If professional design services or certifications by a design professional related to systems, materials or equipment are specifically required of Contractor by the Contract Documents, Owner and Engineer will specify all performance and design criteria that such services must satisfy. Contractor shall cause such services or certifications to be provided by a properly licensed professional, whose signature and seal shall appear on all drawings, calculations, specifications, certifications, Shop Drawings and other submittals prepared by such professional. Shop Drawings and other submittals related to the Work designed or certified by such professional, if prepared by others, shall bear such professional's written approval when submitted to Engineer.
- C. Owner and Engineer shall be entitled to rely upon the adequacy, accuracy and completeness of the services, certifications or approvals performed by such design professionals, provided Owner and Engineer have specified to Contractor all performance and design criteria that such services must satisfy.
- D. Pursuant to this Paragraph 6.21, Engineer's review and approval of design calculations and design drawings will be only for the limited purpose of checking for conformance with performance and design criteria given and the design concept expressed in the Contract Documents. Engineer's review and approval of Shop Drawings and other submittals (except design calculations and design drawings) will be only for the purpose stated in Paragraph 6.17.D.1.
- E. Contractor shall not be responsible for the adequacy of the performance or design criteria required by the Contract Documents.

### **ARTICLE 7 – OTHER WORK AT THE SITE**

#### 7.01 *Related Work at Site*

- A. Owner may perform other work related to the Project at the Site with Owner's employees, or through other direct contracts therefor, or have other work performed by utility owners. If such other work is not noted in the Contract Documents, then:
  1. written notice thereof will be given to Contractor prior to starting any such other work; and

2. if Owner and Contractor are unable to agree on entitlement to or on the amount or extent, if any, of any adjustment in the Contract Price or Contract Times that should be allowed as a result of such other work, a Claim may be made therefor as provided in Paragraph 10.05.
- B. Contractor shall afford each other contractor who is a party to such a direct contract, each utility owner, and Owner, if Owner is performing other work with Owner's employees, proper and safe access to the Site, provide a reasonable opportunity for the introduction and storage of materials and equipment and the execution of such other work, and properly coordinate the Work with theirs. Contractor shall do all cutting, fitting, and patching of the Work that may be required to properly connect or otherwise make its several parts come together and properly integrate with such other work. Contractor shall not endanger any work of others by cutting, excavating, or otherwise altering such work; provided, however, that Contractor may cut or alter others' work with the written consent of Engineer and the others whose work will be affected. The duties and responsibilities of Contractor under this Paragraph are for the benefit of such utility owners and other contractors to the extent that there are comparable provisions for the benefit of Contractor in said direct contracts between Owner and such utility owners and other contractors.
  - C. If the proper execution or results of any part of Contractor's Work depends upon work performed by others under this Article 7, Contractor shall inspect such other work and promptly report to Engineer in writing any delays, defects, or deficiencies in such other work that render it unavailable or unsuitable for the proper execution and results of Contractor's Work. Contractor's failure to so report will constitute an acceptance of such other work as fit and proper for integration with Contractor's Work except for latent defects and deficiencies in such other work.

#### 7.02 *Coordination*

- A. If Owner intends to contract with others for the performance of other work on the Project at the Site, the following will be set forth in Supplementary Conditions:
  1. the individual or entity who will have authority and responsibility for coordination of the activities among the various contractors will be identified;
  2. the specific matters to be covered by such authority and responsibility will be itemized; and
  3. the extent of such authority and responsibilities will be provided.
- B. Unless otherwise provided in the Supplementary Conditions, Owner shall have sole authority and responsibility for such coordination.

#### 7.03 *Legal Relationships*

- A. Paragraphs 7.01.A and 7.02 are not applicable for utilities not under the control of Owner.

- B. Each other direct contract of Owner under Paragraph 7.01.A shall provide that the other contractor is liable to Owner and Contractor for the reasonable direct delay and disruption costs incurred by Contractor as a result of the other contractor's wrongful actions or inactions.
- C. Contractor shall be liable to Owner and any other contractor under direct contract to Owner for the reasonable direct delay and disruption costs incurred by such other contractor as a result of Contractor's wrongful action or inactions.

## **ARTICLE 8 – OWNER'S RESPONSIBILITIES**

### **8.01 *Communications to Contractor***

- A. Except as otherwise provided in these General Conditions, Owner shall issue all communications to Contractor through Engineer.

### **8.02 *Replacement of Engineer***

- A. In case of termination of the employment of Engineer, Owner shall appoint an engineer to whom Contractor makes no reasonable objection, whose status under the Contract Documents shall be that of the former Engineer.

### **8.03 *Furnish Data***

- A. Owner shall promptly furnish the data required of Owner under the Contract Documents.

### **8.04 *Pay When Due***

- A. Owner shall make payments to Contractor when they are due as provided in Paragraphs 14.02.C and 14.07.C.

### **8.05 *Lands and Easements; Reports and Tests***

- A. Owner's duties with respect to providing lands and easements and providing engineering surveys to establish reference points are set forth in Paragraphs 4.01 and 4.05. Paragraph 4.02 refers to Owner's identifying and making available to Contractor copies of reports of explorations and tests of subsurface conditions and drawings of physical conditions relating to existing surface or subsurface structures at the Site.

### **8.06 *Insurance***

- A. Owner's responsibilities, if any, with respect to purchasing and maintaining liability and property insurance are set forth in Article 5.

### **8.07 *Change Orders***

- A. Owner is obligated to execute Change Orders as indicated in Paragraph 10.03.

8.08 *Inspections, Tests, and Approvals*

- A. Owner's responsibility with respect to certain inspections, tests, and approvals is set forth in Paragraph 13.03.B.

8.09 *Limitations on Owner's Responsibilities*

- A. The Owner shall not supervise, direct, or have control or authority over, nor be responsible for, Contractor's means, methods, techniques, sequences, or procedures of construction, or the safety precautions and programs incident thereto, or for any failure of Contractor to comply with Laws and Regulations applicable to the performance of the Work. Owner will not be responsible for Contractor's failure to perform the Work in accordance with the Contract Documents.

8.10 *Undisclosed Hazardous Environmental Condition*

- A. Owner's responsibility in respect to an undisclosed Hazardous Environmental Condition is set forth in Paragraph 4.06.

8.11 *Evidence of Financial Arrangements*

- A. Upon request of Contractor, Owner shall furnish Contractor reasonable evidence that financial arrangements have been made to satisfy Owner's obligations under the Contract Documents.

8.12 *Compliance with Safety Program*

- A. While at the Site, Owner's employees and representatives shall comply with the specific applicable requirements of Contractor's safety programs of which Owner has been informed pursuant to Paragraph 6.13.D.

**ARTICLE 9 – ENGINEER'S STATUS DURING CONSTRUCTION**

9.01 *Owner's Representative*

- A. Engineer will be Owner's representative during the construction period. The duties and responsibilities and the limitations of authority of Engineer as Owner's representative during construction are set forth in the Contract Documents.

9.02 *Visits to Site*

- A. Engineer will make visits to the Site at intervals appropriate to the various stages of construction as Engineer deems necessary in order to observe as an experienced and qualified design professional the progress that has been made and the quality of the various aspects of Contractor's executed Work. Based on information obtained during such visits and observations, Engineer, for the benefit of Owner, will determine, in general, if the Work is proceeding in accordance with the Contract Documents. Engineer will not be required to make exhaustive or continuous inspections on the Site to check the quality or quantity of the Work.

Engineer's efforts will be directed toward providing for Owner a greater degree of confidence that the completed Work will conform generally to the Contract Documents. On the basis of such visits and observations, Engineer will keep Owner informed of the progress of the Work and will endeavor to guard Owner against defective Work.

- B. Engineer's visits and observations are subject to all the limitations on Engineer's authority and responsibility set forth in Paragraph 9.09. Particularly, but without limitation, during or as a result of Engineer's visits or observations of Contractor's Work, Engineer will not supervise, direct, control, or have authority over or be responsible for Contractor's means, methods, techniques, sequences, or procedures of construction, or the safety precautions and programs incident thereto, or for any failure of Contractor to comply with Laws and Regulations applicable to the performance of the Work.

#### 9.03 *Project Representative*

- A. If Owner and Engineer agree, Engineer will furnish a Resident Project Representative to assist Engineer in providing more extensive observation of the Work. The authority and responsibilities of any such Resident Project Representative and assistants will be as provided in the Supplementary Conditions, and limitations on the responsibilities thereof will be as provided in Paragraph 9.09. If Owner designates another representative or agent to represent Owner at the Site who is not Engineer's consultant, agent or employee, the responsibilities and authority and limitations thereon of such other individual or entity will be as provided in the Supplementary Conditions.

#### 9.04 *Authorized Variations in Work*

- A. Engineer may authorize minor variations in the Work from the requirements of the Contract Documents which do not involve an adjustment in the Contract Price or the Contract Times and are compatible with the design concept of the completed Project as a functioning whole as indicated by the Contract Documents. These may be accomplished by a Field Order and will be binding on Owner and also on Contractor, who shall perform the Work involved promptly. If Owner or Contractor believes that a Field Order justifies an adjustment in the Contract Price or Contract Times, or both, and the parties are unable to agree on entitlement to or on the amount or extent, if any, of any such adjustment, a Claim may be made therefor as provided in Paragraph 10.05.

#### 9.05 *Rejecting Defective Work*

- A. Engineer will have authority to reject Work which Engineer believes to be defective, or that Engineer believes will not produce a completed Project that conforms to the Contract Documents or that will prejudice the integrity of the design concept of the completed Project as a functioning whole as indicated by the Contract Documents. Engineer will also have authority to require special inspection or testing of the Work as provided in Paragraph 13.04, whether or not the Work is fabricated, installed, or completed.

9.06 *Shop Drawings, Change Orders and Payments*

- A. In connection with Engineer's authority, and limitations thereof, as to Shop Drawings and Samples, see Paragraph 6.17.
- B. In connection with Engineer's authority, and limitations thereof, as to design calculations and design drawings submitted in response to a delegation of professional design services, if any, see Paragraph 6.21.
- C. In connection with Engineer's authority as to Change Orders, see Articles 10, 11, and 12.
- D. In connection with Engineer's authority as to Applications for Payment, see Article 14.

9.07 *Determinations for Unit Price Work*

- A. Engineer will determine the actual quantities and classifications of Unit Price Work performed by Contractor. Engineer will review with Contractor the Engineer's preliminary determinations on such matters before rendering a written decision thereon (by recommendation of an Application for Payment or otherwise). Engineer's written decision thereon will be final and binding (except as modified by Engineer to reflect changed factual conditions or more accurate data) upon Owner and Contractor, subject to the provisions of Paragraph 10.05.

9.08 *Decisions on Requirements of Contract Documents and Acceptability of Work*

- A. Engineer will be the initial interpreter of the requirements of the Contract Documents and judge of the acceptability of the Work thereunder. All matters in question and other matters between Owner and Contractor arising prior to the date final payment is due relating to the acceptability of the Work, and the interpretation of the requirements of the Contract Documents pertaining to the performance of the Work, will be referred initially to Engineer in writing within 30 days of the event giving rise to the question.
- B. Engineer will, with reasonable promptness, render a written decision on the issue referred. If Owner or Contractor believes that any such decision entitles them to an adjustment in the Contract Price or Contract Times or both, a Claim may be made under Paragraph 10.05. The date of Engineer's decision shall be the date of the event giving rise to the issues referenced for the purposes of Paragraph 10.05.B.
- C. Engineer's written decision on the issue referred will be final and binding on Owner and Contractor, subject to the provisions of Paragraph 10.05.
- D. When functioning as interpreter and judge under this Paragraph 9.08, Engineer will not show partiality to Owner or Contractor and will not be liable in connection with any interpretation or decision rendered in good faith in such capacity.

## 9.09 *Limitations on Engineer's Authority and Responsibilities*

- A. Neither Engineer's authority or responsibility under this Article 9 or under any other provision of the Contract Documents nor any decision made by Engineer in good faith either to exercise or not exercise such authority or responsibility or the undertaking, exercise, or performance of any authority or responsibility by Engineer shall create, impose, or give rise to any duty in contract, tort, or otherwise owed by Engineer to Contractor, any Subcontractor, any Supplier, any other individual or entity, or to any surety for or employee or agent of any of them.
- B. Engineer will not supervise, direct, control, or have authority over or be responsible for Contractor's means, methods, techniques, sequences, or procedures of construction, or the safety precautions and programs incident thereto, or for any failure of Contractor to comply with Laws and Regulations applicable to the performance of the Work. Engineer will not be responsible for Contractor's failure to perform the Work in accordance with the Contract Documents.
- C. Engineer will not be responsible for the acts or omissions of Contractor or of any Subcontractor, any Supplier, or of any other individual or entity performing any of the Work.
- D. Engineer's review of the final Application for Payment and accompanying documentation and all maintenance and operating instructions, schedules, guarantees, bonds, certificates of inspection, tests and approvals, and other documentation required to be delivered by Paragraph 14.07.A will only be to determine generally that their content complies with the requirements of, and in the case of certificates of inspections, tests, and approvals that the results certified indicate compliance with, the Contract Documents.
- E. The limitations upon authority and responsibility set forth in this Paragraph 9.09 shall also apply to the Resident Project Representative, if any, and assistants, if any.

## 9.10 *Compliance with Safety Program*

- A. While at the Site, Engineer's employees and representatives shall comply with the specific applicable requirements of Contractor's safety programs of which Engineer has been informed pursuant to Paragraph 6.13.D.

## **ARTICLE 10 – CHANGES IN THE WORK; CLAIMS**

### 10.01 *Authorized Changes in the Work*

- A. Without invalidating the Contract and without notice to any surety, Owner may, at any time or from time to time, order additions, deletions, or revisions in the Work by a Change Order, or a Work Change Directive. Upon receipt of any such document, Contractor shall promptly proceed with the Work involved which will be performed under the applicable conditions of the Contract Documents (except as otherwise specifically provided).
- B. If Owner and Contractor are unable to agree on entitlement to, or on the amount or extent, if any, of an adjustment in the Contract Price or Contract Times, or both, that should be allowed



as a result of a Work Change Directive, a Claim may be made therefor as provided in Paragraph 10.05.

#### 10.02 *Unauthorized Changes in the Work*

- A. Contractor shall not be entitled to an increase in the Contract Price or an extension of the Contract Times with respect to any work performed that is not required by the Contract Documents as amended, modified, or supplemented as provided in Paragraph 3.04, except in the case of an emergency as provided in Paragraph 6.16 or in the case of uncovering Work as provided in Paragraph 13.04.D.

#### 10.03 *Execution of Change Orders*

- A. Owner and Contractor shall execute appropriate Change Orders recommended by Engineer covering:
  - 1. changes in the Work which are: (i) ordered by Owner pursuant to Paragraph 10.01.A, (ii) required because of acceptance of defective Work under Paragraph 13.08.A or Owner's correction of defective Work under Paragraph 13.09, or (iii) agreed to by the parties;
  - 2. changes in the Contract Price or Contract Times which are agreed to by the parties, including any undisputed sum or amount of time for Work actually performed in accordance with a Work Change Directive; and
  - 3. changes in the Contract Price or Contract Times which embody the substance of any written decision rendered by Engineer pursuant to Paragraph 10.05; provided that, in lieu of executing any such Change Order, an appeal may be taken from any such decision in accordance with the provisions of the Contract Documents and applicable Laws and Regulations, but during any such appeal, Contractor shall carry on the Work and adhere to the Progress Schedule as provided in Paragraph 6.18.A.

#### 10.04 *Notification to Surety*

- A. If the provisions of any bond require notice to be given to a surety of any change affecting the general scope of the Work or the provisions of the Contract Documents (including, but not limited to, Contract Price or Contract Times), the giving of any such notice will be Contractor's responsibility. The amount of each applicable bond will be adjusted to reflect the effect of any such change.

#### 10.05 *Claims*

- A. *Engineer's Decision Required:* All Claims, except those waived pursuant to Paragraph 14.09, shall be referred to the Engineer for decision. A decision by Engineer shall be required as a condition precedent to any exercise by Owner or Contractor of any rights or remedies either may otherwise have under the Contract Documents or by Laws and Regulations in respect of such Claims.

- B. *Notice:* Written notice stating the general nature of each Claim shall be delivered by the claimant to Engineer and the other party to the Contract promptly (but in no event later than 30 days) after the start of the event giving rise thereto. The responsibility to substantiate a Claim shall rest with the party making the Claim. Notice of the amount or extent of the Claim, with supporting data shall be delivered to the Engineer and the other party to the Contract within 60 days after the start of such event (unless Engineer allows additional time for claimant to submit additional or more accurate data in support of such Claim). A Claim for an adjustment in Contract Price shall be prepared in accordance with the provisions of Paragraph 12.01.B. A Claim for an adjustment in Contract Times shall be prepared in accordance with the provisions of Paragraph 12.02.B. Each Claim shall be accompanied by claimant's written statement that the adjustment claimed is the entire adjustment to which the claimant believes it is entitled as a result of said event. The opposing party shall submit any response to Engineer and the claimant within 30 days after receipt of the claimant's last submittal (unless Engineer allows additional time).
- C. *Engineer's Action:* Engineer will review each Claim and, within 30 days after receipt of the last submittal of the claimant or the last submittal of the opposing party, if any, take one of the following actions in writing:
1. deny the Claim in whole or in part;
  2. approve the Claim; or
  3. notify the parties that the Engineer is unable to resolve the Claim if, in the Engineer's sole discretion, it would be inappropriate for the Engineer to do so. For purposes of further resolution of the Claim, such notice shall be deemed a denial.
- D. In the event that Engineer does not take action on a Claim within said 30 days, the Claim shall be deemed denied.
- E. Engineer's written action under Paragraph 10.05.C or denial pursuant to Paragraphs 10.05.C.3 or 10.05.D will be final and binding upon Owner and Contractor, unless Owner or Contractor invoke the dispute resolution procedure set forth in Article 16 within 30 days of such action or denial.
- F. No Claim for an adjustment in Contract Price or Contract Times will be valid if not submitted in accordance with this Paragraph 10.05.

## **ARTICLE 11 – COST OF THE WORK; ALLOWANCES; UNIT PRICE WORK**

### **11.01 *Cost of the Work***

- A. *Costs Included:* The term Cost of the Work means the sum of all costs, except those excluded in Paragraph 11.01.B, necessarily incurred and paid by Contractor in the proper performance of the Work. When the value of any Work covered by a Change Order or when a Claim for an adjustment in Contract Price is determined on the basis of Cost of the Work, the costs to be reimbursed to Contractor will be only those additional or incremental costs required because

of the change in the Work or because of the event giving rise to the Claim. Except as otherwise may be agreed to in writing by Owner, such costs shall be in amounts no higher than those prevailing in the locality of the Project, shall not include any of the costs itemized in Paragraph 11.01.B, and shall include only the following items:

1. Payroll costs for employees in the direct employ of Contractor in the performance of the Work under schedules of job classifications agreed upon by Owner and Contractor. Such employees shall include, without limitation, superintendents, foremen, and other personnel employed full time on the Work. Payroll costs for employees not employed full time on the Work shall be apportioned on the basis of their time spent on the Work. Payroll costs shall include, but not be limited to, salaries and wages plus the cost of fringe benefits, which shall include social security contributions, unemployment, excise, and payroll taxes, workers' compensation, health and retirement benefits, bonuses, sick leave, vacation and holiday pay applicable thereto. The expenses of performing Work outside of regular working hours, on Saturday, Sunday, or legal holidays, shall be included in the above to the extent authorized by Owner.
2. Cost of all materials and equipment furnished and incorporated in the Work, including costs of transportation and storage thereof, and Suppliers' field services required in connection therewith. All cash discounts shall accrue to Contractor unless Owner deposits funds with Contractor with which to make payments, in which case the cash discounts shall accrue to Owner. All trade discounts, rebates and refunds and returns from sale of surplus materials and equipment shall accrue to Owner, and Contractor shall make provisions so that they may be obtained.
3. Payments made by Contractor to Subcontractors for Work performed by Subcontractors. If required by Owner, Contractor shall obtain competitive bids from subcontractors acceptable to Owner and Contractor and shall deliver such bids to Owner, who will then determine, with the advice of Engineer, which bids, if any, will be acceptable. If any subcontract provides that the Subcontractor is to be paid on the basis of Cost of the Work plus a fee, the Subcontractor's Cost of the Work and fee shall be determined in the same manner as Contractor's Cost of the Work and fee as provided in this Paragraph 11.01.
4. Costs of special consultants (including but not limited to engineers, architects, testing laboratories, surveyors, attorneys, and accountants) employed for services specifically related to the Work.
5. Supplemental costs including the following:
  - a. The proportion of necessary transportation, travel, and subsistence expenses of Contractor's employees incurred in discharge of duties connected with the Work.
  - b. Cost, including transportation and maintenance, of all materials, supplies, equipment, machinery, appliances, office, and temporary facilities at the Site, and hand tools not owned by the workers, which are consumed in the performance of the Work, and cost,

less market value, of such items used but not consumed which remain the property of Contractor.

- c. Rentals of all construction equipment and machinery, and the parts thereof whether rented from Contractor or others in accordance with rental agreements approved by Owner with the advice of Engineer, and the costs of transportation, loading, unloading, assembly, dismantling, and removal thereof. All such costs shall be in accordance with the terms of said rental agreements. The rental of any such equipment, machinery, or parts shall cease when the use thereof is no longer necessary for the Work.
- d. Sales, consumer, use, and other similar taxes related to the Work, and for which Contractor is liable, as imposed by Laws and Regulations.
- e. Deposits lost for causes other than negligence of Contractor, any Subcontractor, or anyone directly or indirectly employed by any of them or for whose acts any of them may be liable, and royalty payments and fees for permits and licenses.
- f. Losses and damages (and related expenses) caused by damage to the Work, not compensated by insurance or otherwise, sustained by Contractor in connection with the performance of the Work (except losses and damages within the deductible amounts of property insurance established in accordance with Paragraph 5.06.D), provided such losses and damages have resulted from causes other than the negligence of Contractor, any Subcontractor, or anyone directly or indirectly employed by any of them or for whose acts any of them may be liable. Such losses shall include settlements made with the written consent and approval of Owner. No such losses, damages, and expenses shall be included in the Cost of the Work for the purpose of determining Contractor's fee.
- g. The cost of utilities, fuel, and sanitary facilities at the Site.
- h. Minor expenses such as telegrams, long distance telephone calls, telephone service at the Site, express and courier services, and similar petty cash items in connection with the Work.
- i. The costs of premiums for all bonds and insurance Contractor is required by the Contract Documents to purchase and maintain.

B. *Costs Excluded:* The term Cost of the Work shall not include any of the following items:

- 1. Payroll costs and other compensation of Contractor's officers, executives, principals (of partnerships and sole proprietorships), general managers, safety managers, engineers, architects, estimators, attorneys, auditors, accountants, purchasing and contracting agents, expeditors, timekeepers, clerks, and other personnel employed by Contractor, whether at the Site or in Contractor's principal or branch office for general administration of the Work and not specifically included in the agreed upon schedule of job classifications referred to in Paragraph 11.01.A.1 or specifically covered by Paragraph 11.01.A.4, all of which are to be considered administrative costs covered by the Contractor's fee.

2. Expenses of Contractor's principal and branch offices other than Contractor's office at the Site.
  3. Any part of Contractor's capital expenses, including interest on Contractor's capital employed for the Work and charges against Contractor for delinquent payments.
  4. Costs due to the negligence of Contractor, any Subcontractor, or anyone directly or indirectly employed by any of them or for whose acts any of them may be liable, including but not limited to, the correction of defective Work, disposal of materials or equipment wrongly supplied, and making good any damage to property.
  5. Other overhead or general expense costs of any kind and the costs of any item not specifically and expressly included in Paragraphs 11.01.A.
- C. *Contractor's Fee:* When all the Work is performed on the basis of cost-plus, Contractor's fee shall be determined as set forth in the Agreement. When the value of any Work covered by a Change Order or when a Claim for an adjustment in Contract Price is determined on the basis of Cost of the Work, Contractor's fee shall be determined as set forth in Paragraph 12.01.C.
- D. *Documentation:* Whenever the Cost of the Work for any purpose is to be determined pursuant to Paragraphs 11.01.A and 11.01.B, Contractor will establish and maintain records thereof in accordance with generally accepted accounting practices and submit in a form acceptable to Engineer an itemized cost breakdown together with supporting data.

## 11.02 Allowances

- A. It is understood that Contractor has included in the Contract Price all allowances so named in the Contract Documents and shall cause the Work so covered to be performed for such sums and by such persons or entities as may be acceptable to Owner and Engineer.
- B. *Cash Allowances:*
1. Contractor agrees that:
    - a. the cash allowances include the cost to Contractor (less any applicable trade discounts) of materials and equipment required by the allowances to be delivered at the Site, and all applicable taxes; and
    - b. Contractor's costs for unloading and handling on the Site, labor, installation, overhead, profit, and other expenses contemplated for the cash allowances have been included in the Contract Price and not in the allowances, and no demand for additional payment on account of any of the foregoing will be valid.
- C. *Contingency Allowance:*
1. Contractor agrees that a contingency allowance, if any, is for the sole use of Owner to cover unanticipated costs.

- D. Prior to final payment, an appropriate Change Order will be issued as recommended by Engineer to reflect actual amounts due Contractor on account of Work covered by allowances, and the Contract Price shall be correspondingly adjusted.

#### 11.03 *Unit Price Work*

- A. Where the Contract Documents provide that all or part of the Work is to be Unit Price Work, initially the Contract Price will be deemed to include for all Unit Price Work an amount equal to the sum of the unit price for each separately identified item of Unit Price Work times the estimated quantity of each item as indicated in the Agreement.
- B. The estimated quantities of items of Unit Price Work are not guaranteed and are solely for the purpose of comparison of Bids and determining an initial Contract Price. Determinations of the actual quantities and classifications of Unit Price Work performed by Contractor will be made by Engineer subject to the provisions of Paragraph 9.07.
- C. Each unit price will be deemed to include an amount considered by Contractor to be adequate to cover Contractor's overhead and profit for each separately identified item.
- D. Owner or Contractor may make a Claim for an adjustment in the Contract Price in accordance with Paragraph 10.05 if:
  - 1. the quantity of any item of Unit Price Work performed by Contractor differs materially and significantly from the estimated quantity of such item indicated in the Agreement; and
  - 2. there is no corresponding adjustment with respect to any other item of Work; and
  - 3. Contractor believes that Contractor is entitled to an increase in Contract Price as a result of having incurred additional expense or Owner believes that Owner is entitled to a decrease in Contract Price and the parties are unable to agree as to the amount of any such increase or decrease.

### **ARTICLE 12 – CHANGE OF CONTRACT PRICE; CHANGE OF CONTRACT TIMES**

#### 12.01 *Change of Contract Price*

- A. The Contract Price may only be changed by a Change Order. Any Claim for an adjustment in the Contract Price shall be based on written notice submitted by the party making the Claim to the Engineer and the other party to the Contract in accordance with the provisions of Paragraph 10.05.
- B. The value of any Work covered by a Change Order or of any Claim for an adjustment in the Contract Price will be determined as follows:
  - 1. where the Work involved is covered by unit prices contained in the Contract Documents, by application of such unit prices to the quantities of the items involved (subject to the provisions of Paragraph 11.03); or

2. where the Work involved is not covered by unit prices contained in the Contract Documents, by a mutually agreed lump sum (which may include an allowance for overhead and profit not necessarily in accordance with Paragraph 12.01.C.2); or
  3. where the Work involved is not covered by unit prices contained in the Contract Documents and agreement to a lump sum is not reached under Paragraph 12.01.B.2, on the basis of the Cost of the Work (determined as provided in Paragraph 11.01) plus a Contractor's fee for overhead and profit (determined as provided in Paragraph 12.01.C).
- C. *Contractor's Fee:* The Contractor's fee for overhead and profit shall be determined as follows:
1. a mutually acceptable fixed fee; or
  2. if a fixed fee is not agreed upon, then a fee based on the following percentages of the various portions of the Cost of the Work:
    - a. for costs incurred under Paragraphs 11.01.A.1 and 11.01.A.2, the Contractor's fee shall be 15 percent;
    - b. for costs incurred under Paragraph 11.01.A.3, the Contractor's fee shall be five percent;
    - c. where one or more tiers of subcontracts are on the basis of Cost of the Work plus a fee and no fixed fee is agreed upon, the intent of Paragraphs 12.01.C.2.a and 12.01.C.2.b is that the Subcontractor who actually performs the Work, at whatever tier, will be paid a fee of 15 percent of the costs incurred by such Subcontractor under Paragraphs 11.01.A.1 and 11.01.A.2 and that any higher tier Subcontractor and Contractor will each be paid a fee of five percent of the amount paid to the next lower tier Subcontractor;
    - d. no fee shall be payable on the basis of costs itemized under Paragraphs 11.01.A.4, 11.01.A.5, and 11.01.B;
    - e. the amount of credit to be allowed by Contractor to Owner for any change which results in a net decrease in cost will be the amount of the actual net decrease in cost plus a deduction in Contractor's fee by an amount equal to five percent of such net decrease; and
    - f. when both additions and credits are involved in any one change, the adjustment in Contractor's fee shall be computed on the basis of the net change in accordance with Paragraphs 12.01.C.2.a through 12.01.C.2.e, inclusive.

## 12.02 *Change of Contract Times*

- A. The Contract Times may only be changed by a Change Order. Any Claim for an adjustment in the Contract Times shall be based on written notice submitted by the party making the Claim to the Engineer and the other party to the Contract in accordance with the provisions of Paragraph 10.05.

- B. Any adjustment of the Contract Times covered by a Change Order or any Claim for an adjustment in the Contract Times will be determined in accordance with the provisions of this Article 12.

### 12.03 *Delays*

- A. Where Contractor is prevented from completing any part of the Work within the Contract Times due to delay beyond the control of Contractor, the Contract Times will be extended in an amount equal to the time lost due to such delay if a Claim is made therefor as provided in Paragraph 12.02.A. Delays beyond the control of Contractor shall include, but not be limited to, acts or neglect by Owner, acts or neglect of utility owners or other contractors performing other work as contemplated by Article 7, fires, floods, epidemics, abnormal weather conditions, or acts of God.
- B. If Owner, Engineer, or other contractors or utility owners performing other work for Owner as contemplated by Article 7, or anyone for whom Owner is responsible, delays, disrupts, or interferes with the performance or progress of the Work, then Contractor shall be entitled to an equitable adjustment in the Contract Price or the Contract Times, or both. Contractor's entitlement to an adjustment of the Contract Times is conditioned on such adjustment being essential to Contractor's ability to complete the Work within the Contract Times.
- C. If Contractor is delayed in the performance or progress of the Work by fire, flood, epidemic, abnormal weather conditions, acts of God, acts or failures to act of utility owners not under the control of Owner, or other causes not the fault of and beyond control of Owner and Contractor, then Contractor shall be entitled to an equitable adjustment in Contract Times, if such adjustment is essential to Contractor's ability to complete the Work within the Contract Times. Such an adjustment shall be Contractor's sole and exclusive remedy for the delays described in this Paragraph 12.03.C.
- D. Owner, Engineer, and their officers, directors, members, partners, employees, agents, consultants, or subcontractors shall not be liable to Contractor for any claims, costs, losses, or damages (including but not limited to all fees and charges of engineers, architects, attorneys, and other professionals and all court or arbitration or other dispute resolution costs) sustained by Contractor on or in connection with any other project or anticipated project.
- E. Contractor shall not be entitled to an adjustment in Contract Price or Contract Times for delays within the control of Contractor. Delays attributable to and within the control of a Subcontractor or Supplier shall be deemed to be delays within the control of Contractor.

## **ARTICLE 13 – TESTS AND INSPECTIONS; CORRECTION, REMOVAL OR ACCEPTANCE OF DEFECTIVE WORK**

### 13.01 *Notice of Defects*

- A. Prompt notice of all defective Work of which Owner or Engineer has actual knowledge will be given to Contractor. Defective Work may be rejected, corrected, or accepted as provided in this Article 13.



### 13.02 *Access to Work*

- A. Owner, Engineer, their consultants and other representatives and personnel of Owner, independent testing laboratories, and governmental agencies with jurisdictional interests will have access to the Site and the Work at reasonable times for their observation, inspection, and testing. Contractor shall provide them proper and safe conditions for such access and advise them of Contractor's safety procedures and programs so that they may comply therewith as applicable.

### 13.03 *Tests and Inspections*

- A. Contractor shall give Engineer timely notice of readiness of the Work for all required inspections, tests, or approvals and shall cooperate with inspection and testing personnel to facilitate required inspections or tests.
- B. Owner shall employ and pay for the services of an independent testing laboratory to perform all inspections, tests, or approvals required by the Contract Documents except:
  - 1. for inspections, tests, or approvals covered by Paragraphs 13.03.C and 13.03.D below;
  - 2. that costs incurred in connection with tests or inspections conducted pursuant to Paragraph 13.04.B shall be paid as provided in Paragraph 13.04.C; and
  - 3. as otherwise specifically provided in the Contract Documents.
- C. If Laws or Regulations of any public body having jurisdiction require any Work (or part thereof) specifically to be inspected, tested, or approved by an employee or other representative of such public body, Contractor shall assume full responsibility for arranging and obtaining such inspections, tests, or approvals, pay all costs in connection therewith, and furnish Engineer the required certificates of inspection or approval.
- D. Contractor shall be responsible for arranging and obtaining and shall pay all costs in connection with any inspections, tests, or approvals required for Owner's and Engineer's acceptance of materials or equipment to be incorporated in the Work; or acceptance of materials, mix designs, or equipment submitted for approval prior to Contractor's purchase thereof for incorporation in the Work. Such inspections, tests, or approvals shall be performed by organizations acceptable to Owner and Engineer.
- E. If any Work (or the work of others) that is to be inspected, tested, or approved is covered by Contractor without written concurrence of Engineer, Contractor shall, if requested by Engineer, uncover such Work for observation.
- F. Uncovering Work as provided in Paragraph 13.03.E shall be at Contractor's expense unless Contractor has given Engineer timely notice of Contractor's intention to cover the same and Engineer has not acted with reasonable promptness in response to such notice.

#### 13.04 *Uncovering Work*

- A. If any Work is covered contrary to the written request of Engineer, it must, if requested by Engineer, be uncovered for Engineer's observation and replaced at Contractor's expense.
- B. If Engineer considers it necessary or advisable that covered Work be observed by Engineer or inspected or tested by others, Contractor, at Engineer's request, shall uncover, expose, or otherwise make available for observation, inspection, or testing as Engineer may require, that portion of the Work in question, furnishing all necessary labor, material, and equipment.
- C. If it is found that the uncovered Work is defective, Contractor shall pay all claims, costs, losses, and damages (including but not limited to all fees and charges of engineers, architects, attorneys, and other professionals and all court or arbitration or other dispute resolution costs) arising out of or relating to such uncovering, exposure, observation, inspection, and testing, and of satisfactory replacement or reconstruction (including but not limited to all costs of repair or replacement of work of others); and Owner shall be entitled to an appropriate decrease in the Contract Price. If the parties are unable to agree as to the amount thereof, Owner may make a Claim therefor as provided in Paragraph 10.05.
- D. If the uncovered Work is not found to be defective, Contractor shall be allowed an increase in the Contract Price or an extension of the Contract Times, or both, directly attributable to such uncovering, exposure, observation, inspection, testing, replacement, and reconstruction. If the parties are unable to agree as to the amount or extent thereof, Contractor may make a Claim therefor as provided in Paragraph 10.05.

#### 13.05 *Owner May Stop the Work*

- A. If the Work is defective, or Contractor fails to supply sufficient skilled workers or suitable materials or equipment, or fails to perform the Work in such a way that the completed Work will conform to the Contract Documents, Owner may order Contractor to stop the Work, or any portion thereof, until the cause for such order has been eliminated; however, this right of Owner to stop the Work shall not give rise to any duty on the part of Owner to exercise this right for the benefit of Contractor, any Subcontractor, any Supplier, any other individual or entity, or any surety for, or employee or agent of any of them.

#### 13.06 *Correction or Removal of Defective Work*

- A. Promptly after receipt of written notice, Contractor shall correct all defective Work, whether or not fabricated, installed, or completed, or, if the Work has been rejected by Engineer, remove it from the Project and replace it with Work that is not defective. Contractor shall pay all claims, costs, losses, and damages (including but not limited to all fees and charges of engineers, architects, attorneys, and other professionals and all court or arbitration or other dispute resolution costs) arising out of or relating to such correction or removal (including but not limited to all costs of repair or replacement of work of others).

- B. When correcting defective Work under the terms of this Paragraph 13.06 or Paragraph 13.07, Contractor shall take no action that would void or otherwise impair Owner's special warranty and guarantee, if any, on said Work.

#### 13.07 *Correction Period*

- A. If within one year after the date of Substantial Completion (or such longer period of time as may be prescribed by the terms of any applicable special guarantee required by the Contract Documents) or by any specific provision of the Contract Documents, any Work is found to be defective, or if the repair of any damages to the land or areas made available for Contractor's use by Owner or permitted by Laws and Regulations as contemplated in Paragraph 6.11.A is found to be defective, Contractor shall promptly, without cost to Owner and in accordance with Owner's written instructions:
  - 1. repair such defective land or areas; or
  - 2. correct such defective Work; or
  - 3. if the defective Work has been rejected by Owner, remove it from the Project and replace it with Work that is not defective, and
  - 4. satisfactorily correct or repair or remove and replace any damage to other Work, to the work of others or other land or areas resulting therefrom.
- B. If Contractor does not promptly comply with the terms of Owner's written instructions, or in an emergency where delay would cause serious risk of loss or damage, Owner may have the defective Work corrected or repaired or may have the rejected Work removed and replaced. All claims, costs, losses, and damages (including but not limited to all fees and charges of engineers, architects, attorneys, and other professionals and all court or arbitration or other dispute resolution costs) arising out of or relating to such correction or repair or such removal and replacement (including but not limited to all costs of repair or replacement of work of others) will be paid by Contractor.
- C. In special circumstances where a particular item of equipment is placed in continuous service before Substantial Completion of all the Work, the correction period for that item may start to run from an earlier date if so provided in the Specifications.
- D. Where defective Work (and damage to other Work resulting therefrom) has been corrected or removed and replaced under this Paragraph 13.07, the correction period hereunder with respect to such Work will be extended for an additional period of one year after such correction or removal and replacement has been satisfactorily completed.
- E. Contractor's obligations under this Paragraph 13.07 are in addition to any other obligation or warranty. The provisions of this Paragraph 13.07 shall not be construed as a substitute for, or a waiver of, the provisions of any applicable statute of limitation or repose.

### 13.08 *Acceptance of Defective Work*

- A. If, instead of requiring correction or removal and replacement of defective Work, Owner (and, prior to Engineer's recommendation of final payment, Engineer) prefers to accept it, Owner may do so. Contractor shall pay all claims, costs, losses, and damages (including but not limited to all fees and charges of engineers, architects, attorneys, and other professionals and all court or arbitration or other dispute resolution costs) attributable to Owner's evaluation of and determination to accept such defective Work (such costs to be approved by Engineer as to reasonableness) and for the diminished value of the Work to the extent not otherwise paid by Contractor pursuant to this sentence. If any such acceptance occurs prior to Engineer's recommendation of final payment, a Change Order will be issued incorporating the necessary revisions in the Contract Documents with respect to the Work, and Owner shall be entitled to an appropriate decrease in the Contract Price, reflecting the diminished value of Work so accepted. If the parties are unable to agree as to the amount thereof, Owner may make a Claim therefor as provided in Paragraph 10.05. If the acceptance occurs after such recommendation, an appropriate amount will be paid by Contractor to Owner.

### 13.09 *Owner May Correct Defective Work*

- A. If Contractor fails within a reasonable time after written notice from Engineer to correct defective Work, or to remove and replace rejected Work as required by Engineer in accordance with Paragraph 13.06.A, or if Contractor fails to perform the Work in accordance with the Contract Documents, or if Contractor fails to comply with any other provision of the Contract Documents, Owner may, after seven days written notice to Contractor, correct, or remedy any such deficiency.
- B. In exercising the rights and remedies under this Paragraph 13.09, Owner shall proceed expeditiously. In connection with such corrective or remedial action, Owner may exclude Contractor from all or part of the Site, take possession of all or part of the Work and suspend Contractor's services related thereto, take possession of Contractor's tools, appliances, construction equipment and machinery at the Site, and incorporate in the Work all materials and equipment stored at the Site or for which Owner has paid Contractor but which are stored elsewhere. Contractor shall allow Owner, Owner's representatives, agents and employees, Owner's other contractors, and Engineer and Engineer's consultants access to the Site to enable Owner to exercise the rights and remedies under this Paragraph.
- C. All claims, costs, losses, and damages (including but not limited to all fees and charges of engineers, architects, attorneys, and other professionals and all court or arbitration or other dispute resolution costs) incurred or sustained by Owner in exercising the rights and remedies under this Paragraph 13.09 will be charged against Contractor, and a Change Order will be issued incorporating the necessary revisions in the Contract Documents with respect to the Work; and Owner shall be entitled to an appropriate decrease in the Contract Price. If the parties are unable to agree as to the amount of the adjustment, Owner may make a Claim therefor as provided in Paragraph 10.05. Such claims, costs, losses and damages will include but not be limited to all costs of repair, or replacement of work of others destroyed or damaged by correction, removal, or replacement of Contractor's defective Work.

- D. Contractor shall not be allowed an extension of the Contract Times because of any delay in the performance of the Work attributable to the exercise by Owner of Owner's rights and remedies under this Paragraph 13.09.

## **ARTICLE 14 – PAYMENTS TO CONTRACTOR AND COMPLETION**

### *14.01 Schedule of Values*

- A. The Schedule of Values established as provided in Paragraph 2.07.A will serve as the basis for progress payments and will be incorporated into a form of Application for Payment acceptable to Engineer. Progress payments on account of Unit Price Work will be based on the number of units completed.

### *14.02 Progress Payments*

#### *A. Applications for Payments:*

1. At least 20 days before the date established in the Agreement for each progress payment (but not more often than once a month), Contractor shall submit to Engineer for review an Application for Payment filled out and signed by Contractor covering the Work completed as of the date of the Application and accompanied by such supporting documentation as is required by the Contract Documents. If payment is requested on the basis of materials and equipment not incorporated in the Work but delivered and suitably stored at the Site or at another location agreed to in writing, the Application for Payment shall also be accompanied by a bill of sale, invoice, or other documentation warranting that Owner has received the materials and equipment free and clear of all Liens and evidence that the materials and equipment are covered by appropriate property insurance or other arrangements to protect Owner's interest therein, all of which must be satisfactory to Owner.
2. Beginning with the second Application for Payment, each Application shall include an affidavit of Contractor stating that all previous progress payments received on account of the Work have been applied on account to discharge Contractor's legitimate obligations associated with prior Applications for Payment.
3. The amount of retainage with respect to progress payments will be as stipulated in the Agreement.

#### *B. Review of Applications:*

1. Engineer will, within 10 days after receipt of each Application for Payment, either indicate in writing a recommendation of payment and present the Application to Owner or return the Application to Contractor indicating in writing Engineer's reasons for refusing to recommend payment. In the latter case, Contractor may make the necessary corrections and resubmit the Application.

2. Engineer's recommendation of any payment requested in an Application for Payment will constitute a representation by Engineer to Owner, based on Engineer's observations of the executed Work as an experienced and qualified design professional, and on Engineer's review of the Application for Payment and the accompanying data and schedules, that to the best of Engineer's knowledge, information and belief:
  - a. the Work has progressed to the point indicated;
  - b. the quality of the Work is generally in accordance with the Contract Documents (subject to an evaluation of the Work as a functioning whole prior to or upon Substantial Completion, the results of any subsequent tests called for in the Contract Documents, a final determination of quantities and classifications for Unit Price Work under Paragraph 9.07, and any other qualifications stated in the recommendation); and
  - c. the conditions precedent to Contractor's being entitled to such payment appear to have been fulfilled in so far as it is Engineer's responsibility to observe the Work.
3. By recommending any such payment Engineer will not thereby be deemed to have represented that:
  - a. inspections made to check the quality or the quantity of the Work as it has been performed have been exhaustive, extended to every aspect of the Work in progress, or involved detailed inspections of the Work beyond the responsibilities specifically assigned to Engineer in the Contract Documents; or
  - b. there may not be other matters or issues between the parties that might entitle Contractor to be paid additionally by Owner or entitle Owner to withhold payment to Contractor.
4. Neither Engineer's review of Contractor's Work for the purposes of recommending payments nor Engineer's recommendation of any payment, including final payment, will impose responsibility on Engineer:
  - a. to supervise, direct, or control the Work, or
  - b. for the means, methods, techniques, sequences, or procedures of construction, or the safety precautions and programs incident thereto, or
  - c. for Contractor's failure to comply with Laws and Regulations applicable to Contractor's performance of the Work, or
  - d. to make any examination to ascertain how or for what purposes Contractor has used the moneys paid on account of the Contract Price, or
  - e. to determine that title to any of the Work, materials, or equipment has passed to Owner free and clear of any Liens.

5. Engineer may refuse to recommend the whole or any part of any payment if, in Engineer's opinion, it would be incorrect to make the representations to Owner stated in Paragraph 14.02.B.2. Engineer may also refuse to recommend any such payment or, because of subsequently discovered evidence or the results of subsequent inspections or tests, revise or revoke any such payment recommendation previously made, to such extent as may be necessary in Engineer's opinion to protect Owner from loss because:
  - a. the Work is defective, or completed Work has been damaged, requiring correction or replacement;
  - b. the Contract Price has been reduced by Change Orders;
  - c. Owner has been required to correct defective Work or complete Work in accordance with Paragraph 13.09; or
  - d. Engineer has actual knowledge of the occurrence of any of the events enumerated in Paragraph 15.02.A.

C. *Payment Becomes Due:*

1. Ten days after presentation of the Application for Payment to Owner with Engineer's recommendation, the amount recommended will (subject to the provisions of Paragraph 14.02.D) become due, and when due will be paid by Owner to Contractor.

D. *Reduction in Payment:*

1. Owner may refuse to make payment of the full amount recommended by Engineer because:
  - a. claims have been made against Owner on account of Contractor's performance or furnishing of the Work;
  - b. Liens have been filed in connection with the Work, except where Contractor has delivered a specific bond satisfactory to Owner to secure the satisfaction and discharge of such Liens;
  - c. there are other items entitling Owner to a set-off against the amount recommended; or
  - d. Owner has actual knowledge of the occurrence of any of the events enumerated in Paragraphs 14.02.B.5.a through 14.02.B.5.c or Paragraph 15.02.A.
2. If Owner refuses to make payment of the full amount recommended by Engineer, Owner will give Contractor immediate written notice (with a copy to Engineer) stating the reasons for such action and promptly pay Contractor any amount remaining after deduction of the amount so withheld. Owner shall promptly pay Contractor the amount so withheld, or any

adjustment thereto agreed to by Owner and Contractor, when Contractor remedies the reasons for such action.

3. Upon a subsequent determination that Owner's refusal of payment was not justified, the amount wrongfully withheld shall be treated as an amount due as determined by Paragraph 14.02.C.1 and subject to interest as provided in the Agreement.

#### 14.03 *Contractor's Warranty of Title*

- A. Contractor warrants and guarantees that title to all Work, materials, and equipment covered by any Application for Payment, whether incorporated in the Project or not, will pass to Owner no later than the time of payment free and clear of all Liens.

#### 14.04 *Substantial Completion*

- A. When Contractor considers the entire Work ready for its intended use Contractor shall notify Owner and Engineer in writing that the entire Work is substantially complete (except for items specifically listed by Contractor as incomplete) and request that Engineer issue a certificate of Substantial Completion.
- B. Promptly after Contractor's notification, Owner, Contractor, and Engineer shall make an inspection of the Work to determine the status of completion. If Engineer does not consider the Work substantially complete, Engineer will notify Contractor in writing giving the reasons therefor.
- C. If Engineer considers the Work substantially complete, Engineer will deliver to Owner a tentative certificate of Substantial Completion which shall fix the date of Substantial Completion. There shall be attached to the certificate a tentative list of items to be completed or corrected before final payment. Owner shall have seven days after receipt of the tentative certificate during which to make written objection to Engineer as to any provisions of the certificate or attached list. If, after considering such objections, Engineer concludes that the Work is not substantially complete, Engineer will, within 14 days after submission of the tentative certificate to Owner, notify Contractor in writing, stating the reasons therefor. If, after consideration of Owner's objections, Engineer considers the Work substantially complete, Engineer will, within said 14 days, execute and deliver to Owner and Contractor a definitive certificate of Substantial Completion (with a revised tentative list of items to be completed or corrected) reflecting such changes from the tentative certificate as Engineer believes justified after consideration of any objections from Owner.
- D. At the time of delivery of the tentative certificate of Substantial Completion, Engineer will deliver to Owner and Contractor a written recommendation as to division of responsibilities pending final payment between Owner and Contractor with respect to security, operation, safety, and protection of the Work, maintenance, heat, utilities, insurance, and warranties and guarantees. Unless Owner and Contractor agree otherwise in writing and so inform Engineer in writing prior to Engineer's issuing the definitive certificate of Substantial Completion,



Engineer's aforesaid recommendation will be binding on Owner and Contractor until final payment.

- E. Owner shall have the right to exclude Contractor from the Site after the date of Substantial Completion subject to allowing Contractor reasonable access to remove its property and complete or correct items on the tentative list.

#### 14.05 *Partial Utilization*

- A. Prior to Substantial Completion of all the Work, Owner may use or occupy any substantially completed part of the Work which has specifically been identified in the Contract Documents, or which Owner, Engineer, and Contractor agree constitutes a separately functioning and usable part of the Work that can be used by Owner for its intended purpose without significant interference with Contractor's performance of the remainder of the Work, subject to the following conditions:
  - 1. Owner at any time may request Contractor in writing to permit Owner to use or occupy any such part of the Work which Owner believes to be ready for its intended use and substantially complete. If and when Contractor agrees that such part of the Work is substantially complete, Contractor, Owner, and Engineer will follow the procedures of Paragraph 14.04.A through D for that part of the Work.
  - 2. Contractor at any time may notify Owner and Engineer in writing that Contractor considers any such part of the Work ready for its intended use and substantially complete and request Engineer to issue a certificate of Substantial Completion for that part of the Work.
  - 3. Within a reasonable time after either such request, Owner, Contractor, and Engineer shall make an inspection of that part of the Work to determine its status of completion. If Engineer does not consider that part of the Work to be substantially complete, Engineer will notify Owner and Contractor in writing giving the reasons therefor. If Engineer considers that part of the Work to be substantially complete, the provisions of Paragraph 14.04 will apply with respect to certification of Substantial Completion of that part of the Work and the division of responsibility in respect thereof and access thereto.
  - 4. No use or occupancy or separate operation of part of the Work may occur prior to compliance with the requirements of Paragraph 5.10 regarding property insurance.

#### 14.06 *Final Inspection*

- A. Upon written notice from Contractor that the entire Work or an agreed portion thereof is complete, Engineer will promptly make a final inspection with Owner and Contractor and will notify Contractor in writing of all particulars in which this inspection reveals that the Work is incomplete or defective. Contractor shall immediately take such measures as are necessary to complete such Work or remedy such deficiencies.

## 14.07 *Final Payment*

### A. *Application for Payment:*

1. After Contractor has, in the opinion of Engineer, satisfactorily completed all corrections identified during the final inspection and has delivered, in accordance with the Contract Documents, all maintenance and operating instructions, schedules, guarantees, bonds, certificates or other evidence of insurance, certificates of inspection, marked-up record documents (as provided in Paragraph 6.12), and other documents, Contractor may make application for final payment following the procedure for progress payments.
2. The final Application for Payment shall be accompanied (except as previously delivered) by:
  - a. all documentation called for in the Contract Documents, including but not limited to the evidence of insurance required by Paragraph 5.04.B.6;
  - b. consent of the surety, if any, to final payment;
  - c. a list of all Claims against Owner that Contractor believes are unsettled; and
  - d. complete and legally effective releases or waivers (satisfactory to Owner) of all Lien rights arising out of or Liens filed in connection with the Work.
3. In lieu of the releases or waivers of Liens specified in Paragraph 14.07.A.2 and as approved by Owner, Contractor may furnish receipts or releases in full and an affidavit of Contractor that: (i) the releases and receipts include all labor, services, material, and equipment for which a Lien could be filed; and (ii) all payrolls, material and equipment bills, and other indebtedness connected with the Work for which Owner might in any way be responsible, or which might in any way result in liens or other burdens on Owner's property, have been paid or otherwise satisfied. If any Subcontractor or Supplier fails to furnish such a release or receipt in full, Contractor may furnish a bond or other collateral satisfactory to Owner to indemnify Owner against any Lien.

### B. *Engineer's Review of Application and Acceptance:*

1. If, on the basis of Engineer's observation of the Work during construction and final inspection, and Engineer's review of the final Application for Payment and accompanying documentation as required by the Contract Documents, Engineer is satisfied that the Work has been completed and Contractor's other obligations under the Contract Documents have been fulfilled, Engineer will, within ten days after receipt of the final Application for Payment, indicate in writing Engineer's recommendation of payment and present the Application for Payment to Owner for payment. At the same time Engineer will also give written notice to Owner and Contractor that the Work is acceptable subject to the provisions of Paragraph 14.09. Otherwise, Engineer will return the Application for Payment to Contractor, indicating in writing the reasons for refusing to recommend final payment, in which case Contractor shall make the necessary corrections and resubmit the Application for Payment.

C. *Payment Becomes Due:*

1. Thirty days after the presentation to Owner of the Application for Payment and accompanying documentation, the amount recommended by Engineer, less any sum Owner is entitled to set off against Engineer's recommendation, including but not limited to liquidated damages, will become due and will be paid by Owner to Contractor.

14.08 *Final Completion Delayed*

- A. If, through no fault of Contractor, final completion of the Work is significantly delayed, and if Engineer so confirms, Owner shall, upon receipt of Contractor's final Application for Payment (for Work fully completed and accepted) and recommendation of Engineer, and without terminating the Contract, make payment of the balance due for that portion of the Work fully completed and accepted. If the remaining balance to be held by Owner for Work not fully completed or corrected is less than the retainage stipulated in the Agreement, and if bonds have been furnished as required in Paragraph 5.01, the written consent of the surety to the payment of the balance due for that portion of the Work fully completed and accepted shall be submitted by Contractor to Engineer with the Application for such payment. Such payment shall be made under the terms and conditions governing final payment, except that it shall not constitute a waiver of Claims.

14.09 *Waiver of Claims*

- A. The making and acceptance of final payment will constitute:
  1. a waiver of all Claims by Owner against Contractor, except Claims arising from unsettled Liens, from defective Work appearing after final inspection pursuant to Paragraph 14.06, from failure to comply with the Contract Documents or the terms of any special guarantees specified therein, or from Contractor's continuing obligations under the Contract Documents; and
  2. a waiver of all Claims by Contractor against Owner other than those previously made in accordance with the requirements herein and expressly acknowledged by Owner in writing as still unsettled.

**ARTICLE 15 – SUSPENSION OF WORK AND TERMINATION**

15.01 *Owner May Suspend Work*

- A. At any time and without cause, Owner may suspend the Work or any portion thereof for a period of not more than 90 consecutive days by notice in writing to Contractor and Engineer which will fix the date on which Work will be resumed. Contractor shall resume the Work on the date so fixed. Contractor shall be granted an adjustment in the Contract Price or an extension of the Contract Times, or both, directly attributable to any such suspension if Contractor makes a Claim therefor as provided in Paragraph 10.05.

## 15.02 *Owner May Terminate for Cause*

- A. The occurrence of any one or more of the following events will justify termination for cause:
1. Contractor's persistent failure to perform the Work in accordance with the Contract Documents (including, but not limited to, failure to supply sufficient skilled workers or suitable materials or equipment or failure to adhere to the Progress Schedule established under Paragraph 2.07 as adjusted from time to time pursuant to Paragraph 6.04);
  2. Contractor's disregard of Laws or Regulations of any public body having jurisdiction;
  3. Contractor's repeated disregard of the authority of Engineer; or
  4. Contractor's violation in any substantial way of any provisions of the Contract Documents.
- B. If one or more of the events identified in Paragraph 15.02.A occur, Owner may, after giving Contractor (and surety) seven days written notice of its intent to terminate the services of Contractor:
1. exclude Contractor from the Site, and take possession of the Work and of all Contractor's tools, appliances, construction equipment, and machinery at the Site, and use the same to the full extent they could be used by Contractor (without liability to Contractor for trespass or conversion);
  2. incorporate in the Work all materials and equipment stored at the Site or for which Owner has paid Contractor but which are stored elsewhere; and
  3. complete the Work as Owner may deem expedient.
- C. If Owner proceeds as provided in Paragraph 15.02.B, Contractor shall not be entitled to receive any further payment until the Work is completed. If the unpaid balance of the Contract Price exceeds all claims, costs, losses, and damages (including but not limited to all fees and charges of engineers, architects, attorneys, and other professionals and all court or arbitration or other dispute resolution costs) sustained by Owner arising out of or relating to completing the Work, such excess will be paid to Contractor. If such claims, costs, losses, and damages exceed such unpaid balance, Contractor shall pay the difference to Owner. Such claims, costs, losses, and damages incurred by Owner will be reviewed by Engineer as to their reasonableness and, when so approved by Engineer, incorporated in a Change Order. When exercising any rights or remedies under this Paragraph, Owner shall not be required to obtain the lowest price for the Work performed.
- D. Notwithstanding Paragraphs 15.02.B and 15.02.C, Contractor's services will not be terminated if Contractor begins within seven days of receipt of notice of intent to terminate to correct its failure to perform and proceeds diligently to cure such failure within no more than 30 days of receipt of said notice.

- E. Where Contractor's services have been so terminated by Owner, the termination will not affect any rights or remedies of Owner against Contractor then existing or which may thereafter accrue. Any retention or payment of moneys due Contractor by Owner will not release Contractor from liability.
- F. If and to the extent that Contractor has provided a performance bond under the provisions of Paragraph 5.01.A, the termination procedures of that bond shall supersede the provisions of Paragraphs 15.02.B and 15.02.C.

#### 15.03 *Owner May Terminate For Convenience*

- A. Upon seven days written notice to Contractor and Engineer, Owner may, without cause and without prejudice to any other right or remedy of Owner, terminate the Contract. In such case, Contractor shall be paid for (without duplication of any items):
  - 1. completed and acceptable Work executed in accordance with the Contract Documents prior to the effective date of termination, including fair and reasonable sums for overhead and profit on such Work;
  - 2. expenses sustained prior to the effective date of termination in performing services and furnishing labor, materials, or equipment as required by the Contract Documents in connection with uncompleted Work, plus fair and reasonable sums for overhead and profit on such expenses;
  - 3. all claims, costs, losses, and damages (including but not limited to all fees and charges of engineers, architects, attorneys, and other professionals and all court or arbitration or other dispute resolution costs) incurred in settlement of terminated contracts with Subcontractors, Suppliers, and others; and
  - 4. reasonable expenses directly attributable to termination.
- B. Contractor shall not be paid on account of loss of anticipated profits or revenue or other economic loss arising out of or resulting from such termination.

#### 15.04 *Contractor May Stop Work or Terminate*

- A. If, through no act or fault of Contractor, (i) the Work is suspended for more than 90 consecutive days by Owner or under an order of court or other public authority, or (ii) Engineer fails to act on any Application for Payment within 30 days after it is submitted, or (iii) Owner fails for 30 days to pay Contractor any sum finally determined to be due, then Contractor may, upon seven days written notice to Owner and Engineer, and provided Owner or Engineer do not remedy such suspension or failure within that time, terminate the Contract and recover from Owner payment on the same terms as provided in Paragraph 15.03.
- B. In lieu of terminating the Contract and without prejudice to any other right or remedy, if Engineer has failed to act on an Application for Payment within 30 days after it is submitted, or Owner has failed for 30 days to pay Contractor any sum finally determined to be due,

Contractor may, seven days after written notice to Owner and Engineer, stop the Work until payment is made of all such amounts due Contractor, including interest thereon. The provisions of this Paragraph 15.04 are not intended to preclude Contractor from making a Claim under Paragraph 10.05 for an adjustment in Contract Price or Contract Times or otherwise for expenses or damage directly attributable to Contractor's stopping the Work as permitted by this Paragraph.

## **ARTICLE 16 – DISPUTE RESOLUTION**

### *16.01 Methods and Procedures*

- A. Either Owner or Contractor may request mediation of any Claim submitted to Engineer for a decision under Paragraph 10.05 before such decision becomes final and binding. The mediation will be governed by the Construction Industry Mediation Rules of the American Arbitration Association in effect as of the Effective Date of the Agreement. The request for mediation shall be submitted in writing to the American Arbitration Association and the other party to the Contract. Timely submission of the request shall stay the effect of Paragraph 10.05.E.
- B. Owner and Contractor shall participate in the mediation process in good faith. The process shall be concluded within 60 days of filing of the request. The date of termination of the mediation shall be determined by application of the mediation rules referenced above.
- C. If the Claim is not resolved by mediation, Engineer's action under Paragraph 10.05.C or a denial pursuant to Paragraphs 10.05.C.3 or 10.05.D shall become final and binding 30 days after termination of the mediation unless, within that time period, Owner or Contractor:
  - 1. elects in writing to invoke any dispute resolution process provided for in the Supplementary Conditions; or
  - 2. agrees with the other party to submit the Claim to another dispute resolution process; or
  - 3. gives written notice to the other party of the intent to submit the Claim to a court of competent jurisdiction.

## **ARTICLE 17 – MISCELLANEOUS**

### *17.01 Giving Notice*

- A. Whenever any provision of the Contract Documents requires the giving of written notice, it will be deemed to have been validly given if:
  - 1. delivered in person to the individual or to a member of the firm or to an officer of the corporation for whom it is intended; or
  - 2. delivered at or sent by registered or certified mail, postage prepaid, to the last business address known to the giver of the notice.

#### 17.02 *Computation of Times*

- A. When any period of time is referred to in the Contract Documents by days, it will be computed to exclude the first and include the last day of such period. If the last day of any such period falls on a Saturday or Sunday or on a day made a legal holiday by the law of the applicable jurisdiction, such day will be omitted from the computation.

#### 17.03 *Cumulative Remedies*

- A. The duties and obligations imposed by these General Conditions and the rights and remedies available hereunder to the parties hereto are in addition to, and are not to be construed in any way as a limitation of, any rights and remedies available to any or all of them which are otherwise imposed or available by Laws or Regulations, by special warranty or guarantee, or by other provisions of the Contract Documents. The provisions of this Paragraph will be as effective as if repeated specifically in the Contract Documents in connection with each particular duty, obligation, right, and remedy to which they apply.

#### 17.04 *Survival of Obligations*

- A. All representations, indemnifications, warranties, and guarantees made in, required by, or given in accordance with the Contract Documents, as well as all continuing obligations indicated in the Contract Documents, will survive final payment, completion, and acceptance of the Work or termination or completion of the Contract or termination of the services of Contractor.

#### 17.05 *Controlling Law*

- A. This Contract is to be governed by the law of the state in which the Project is located.

#### 17.06 *Headings*

- A. Article and paragraph headings are inserted for convenience only and do not constitute parts of these General Conditions.





## SUPPLEMENTARY CONDITIONS

### SUPPLEMENTARY CONDITIONS

These Supplementary Conditions amend or supplement the Standard General Conditions of the Construction Contract EJCDC C-700 (2007 Edition). All provisions which are not so amended or supplemented remain in full force and effect.

The terms used in the Supplementary Conditions will have the meanings indicated in the General Conditions. Additional terms used in these Supplementary Conditions have the meanings indicated below, which are applicable to both the singular and plural thereof.

### TABLE OF ARTICLES:

SC-1.01.A.3. Application for Payment  
SC-1.01.A.9. Change Order  
SC-1.01.A.19. Engineer  
SC-1.01.A.44. Substantial Completion  
SC-1.01.A.46. Supplementary Conditions  
SC-1.01.A.52. Abnormal Weather  
SC-2.02. Copies of Documents  
SC-2.03.A. Commencement of Contract Times; Notice to Proceed  
SC-2.08 Access to Person and Records  
SC-3.03.B. Resolving Discrepancies  
SC-4.01. Availability of Lands  
SC-4.02. Subsurface and Physical Conditions  
SC-4.04. Underground Facilities  
SC-4.06. Hazardous Environmental Conditions at Site  
SC-5.03. Certificates of Insurance  
SC-5.04. Contractors Liability Insurance  
SC-5.06 . Property Insurance  
SC-5.11. Hold Harmless  
SC-6.02.B. Labor; Working Hours  
SC-6.05.C. Engineer's Evaluations  
SC-6.06. Concerning Subcontractors, Suppliers, and others  
SC-6.10. Taxes  
SC.6.12. Record Documents  
SC-6.13 Safety and Protection  
SC-6.17. Shop Drawings and Samples  
SC-7.01. Related Work at the Site  
SC-7.02. Coordination  
SC-9.03. Project Representative  
SC-14.02.A. Applications for Payments  
SC-14.02.A.2. CONTRACTOR Affidavit  
SC-14.02.A.3. Retainage  
SC-14.02.C.1 Payment Becomes Due  
SC-14.05. Partial Utilization

SC-1.01.A.3. Application for Payment. Add the following language to the end of paragraph 1.01.A.3:

The Application for Payment form to be used on this Project is attached.

SC-1.01.A.9. Change Order. Add the following language to the end of paragraph 1.01.A.9:

The Change Order form to be used on this Project is attached.

SC-1.01.A.19. Engineer. Add the following at the end of paragraph 1.01.A.19:

Refer to the Agreement, Article 3 – Engineer, for conditions, if any, when the Owner will assume all or part of the duties of the Engineer.

SC-1.01.A.46. Supplementary Conditions. Add the following to the end of paragraph-1.01.A.46:

The words "Special Provisions," "Special Conditions," and "Supplementary Conditions," wherever they may appear in these Contract Documents and Specifications, are used interchangeably and shall be interpreted to mean either "Special Conditions" or "Supplementary Conditions" which ever may be applicable.

SC-1.01.A.52. Abnormal Weather. Add the following new paragraph after 1.01.A.51:

Abnormal weather conditions as mentioned in the General Conditions Article 12.03.A shall be defined as weather more severe than the average of the last ten (10) years. Rainfall measurement shall be considered at 0.1 inch or greater. Normal rainfall for each month shall be the average number of rain days for the last ten (10) years. Time extensions will be considered when the actual number rain days exceeds the ten (10) year monthly average. Impact days, as a result of abnormal weather conditions, will not be considered for time extensions.

SC-2.02. Copies of Documents. SC-2.02.A. Revise the first sentence to read as follows:

- A. The OWNER shall furnish CONTRACTOR three (3) copies of the Drawings & Project Manual.

SC-2.03.A. Commencement of Contract Times; Notice to Proceed. Delete paragraph 2.03.A in its entirety and insert the following in its place:

- A. The Contract Times will commence to run on the day indicated in the Notice to Proceed. A Notice to Proceed may be given at any time within 30 days after the Effective Date of the Agreement.

SC-2.08. Access to Person and Records. Add the following new paragraph after 2.07.

Owner shall have reasonable access to persons and records of Contractor as a result of contract execution.

SC-3.03.B. Resolving Discrepancies. Add the following after paragraph 3.03.B.1.

2. In resolving conflicts, errors and discrepancies, the documents shall be given precedence in the following order: Agreement, Modifications, Addenda, Supplementary Conditions, Special Conditions, General Conditions, Specifications and Drawings. Figure dimensions on Drawings shall govern over scale dimensions, and detailed Drawings shall govern over general Drawings. Any Work that may reasonably be inferred from the Specifications or Drawings as being required to produce the intended result shall be supplied whether or not it is specifically called for. Work, materials or equipment described in words which so applied have a well-known technical or trade meaning shall be deemed to refer to such recognized standards.

SC-4.02. Subsurface and Physical Conditions. Delete paragraph 4.02 in its entirety and insert the following in its place:

4.02 No reports or explorations or tests of subsurface conditions at or contiguous to the site are known to the Owner or Engineer. Contractor shall have full responsibility with respect to subsurface conditions at the site as provided in the Contract Documents.

SC-4.04. Underground Facilities. Add the following to 4.04.A.2:

- e. locating existing service connections which are not indicated on the drawings,
- f. discovering existing underground installations in advance of excavating or trenching, by contacting all local utilities and by prospecting. The CONTRACTOR shall notify North Carolina ONE-CALL at 811 or 1-800-632-4949 at least 72 hours prior to commencing construction in order that existing utilities in the area may be flagged or staked, protecting and maintaining all existing utilities in an operational manner. CONTRACTOR shall note that not all utility owners/operators are members of North Carolina ONE-CALL, and that notifying North Carolina ONE-CALL will not assure that all applicable utilities are located.

SC-4.06. Hazardous Environmental Conditions at Site.

Delete paragraphs 4.06.A and 4.06.B in their entirety and insert the following:

- A. No reports or explorations or tests of subsurface conditions at or contiguous to the site are known to the Owner or Engineer.
- B. Not used.

SC-5.03 . Certificates of Insurance.

Add the following at the end of paragraph 5.03.A.

The following are to be included as additional insured on the policy:

Owner  
Ark Consulting Group, PLLC

SC-5.04. Contractors Liability Insurance. Add the following new paragraph immediately after paragraph 5.04.B:

C. The limits of liability for the insurance required by paragraph 5.04 of the General Conditions shall provide the following coverages for not less than the following amounts or greater where required by Laws and Regulations:

1. Worker's Compensation, etc. under paragraphs 5.04.A.1 and A.2 of the General Conditions:

- |   |                       |
|---|-----------------------|
| a. State:   | Statutory             |
| b. Applicable Federal (e.g., Longshoreman’s):           | Statutory             |
| c. Employer’s Liability:                                | <u>\$1,000,000.00</u> |
| d. Waiver of Subrogation with all required endorsements |                       |

The CONTRACTOR will provide an endorsement to the Contractor’s Workers Compensation and Employer’s Liability Insurance waiving all rights of subrogation by the CONTRACTOR’s insurance carrier against the OWNER and ENGINEER.

2. Contractor's Liability Insurance under paragraphs 5.04.A.3 through A.6 of the General Conditions which shall also include completed operations and product liability coverages and eliminate the exclusion with respect to property under the care, custody and control of CONTRACTOR:

- |  |                       |
|--|-----------------------|
| (a) General Aggregate – Limit applies on a per Project Basis   | <u>\$1,000,000.00</u> |
| (b) Products - Completed Operations Aggregate  | <u>\$1,000,000.00</u> |
| (c) Personal and Advertising Injury (Per Person/Organization)  | <u>\$1,000,000.00</u> |
| (d) Each Occurrence (Bodily Injury and Property Damage)  | <u>\$1,000,000.00</u> |
| (e) Property Damage liability insurance will provide Explosion, Collapse and Underground coverages.              |                       |
| (f) Excess or Umbrella Liability to cover Commercial/General Liability/Auto/Worker’s Comp/ Employer’s Liability. |                       |
| 1. General Aggregate   | <u>\$1,000,000.00</u> |
| 2. Each Occurrence   | <u>\$1,000,000.00</u> |

3. Automobile Liability under paragraph 5.04.A.6 of the General Conditions:

- |                     |                       |
|---------------------|-----------------------|
| a. Bodily Injury:   |                       |
| Each Person         | <u>\$1,000,000.00</u> |
| Each Accident       | <u>\$1,000,000.00</u> |
| b. Property Damage: |                       |
| Each Accident       | <u>\$1,000,000.00</u> |

c. Combined Single Limit of \$1,000,000.00

d. Include hired and non-owned auto

4. The Contractual Liability coverage required by paragraph 5.04.B.4 of the General Conditions shall provide coverage for not less than the following amounts.

a. Bodily Injury:

Each Person \$1,000,000.00

Each Accident \$1,000,000.00

b. Property Damage:

Each Accident \$1,000,000.00

Annual Aggregate \$1,000,000.00

5. Additional Insured: OWNER and ENGINEER. Provide certificates for Contractor, Owner and Engineer with required endorsements.

6. Agent that fills out the Insurance Certificate shall state that they have read specification pages GC-17, 18, 19, 20, 21 and 22, as well as SC-5.03 and SC-5.06 in regards to insurance, and that the policy issued complies with the requirements stated in these conditions.

SC-5.11. Hold Harmless. Add the following paragraph after 5.10.

A. Contractor agrees to protect, defend, indemnify and hold the Owner, its officer, employees and agents free, including the Engineer, harmless from and against any and all losses, penalties, damages, settlement costs, charges, professional fees or other expenses or liabilities of every kind and arising out of or relating to any and all claims, liens, demands, obligations, actions, proceedings, or causes of action of every kind in connection with or arising out of this agreement and/or the performance hereof that are due to the negligence of the Contractor, its officer, employees, or agents. The Contractor further agrees to investigate, handle, respond to, provide defense for and defend the same at its sole expense and agrees to bear all other costs and expenses related thereto.

SC-6.02.B Labor; Working Hours. Add the following to 6.02.B.

Regular working hours shall be between 8:00 a.m. and 5:00 p.m., except as approved by the Owner and Engineer.

SC-6.06. Concerning Subcontractors, Suppliers, and Others. Add a new paragraph immediately after Paragraph 6.06.G:

H. The CONTRACTOR shall not award WORK to Subcontractor(s), in excess of 50 percent of the Contract Price, without prior written approval of the OWNER. Justification must be submitted by the CONTRACTOR to the ENGINEER for recommendations and forwarding to OWNER. The OWNER's refusal to allow an increase in the percent subcontracted will not be grounds for increasing the Contract Price.

- I. Owner may furnish to any Subcontractor or Supplier, to the extent practicable, information about amounts paid to Contractor on account of Work performed for Contractor by a particular Subcontractor or Supplier.

SC-6.10. Taxes. Add the following new paragraph after paragraph 6.10.A:

- B. Contractor and his Subcontractors shall maintain accurate records of payment of N.C. State Sales Tax on materials, supplies, fixtures, and equipment, which become a part of the Work. Contractor shall submit with the Application for Payment a certified statement showing sales tax paid by Contractor and Subcontractors. Certified statement shall list suppliers' invoices showing invoice number, amount paid, tax paid, date and county paid. Sales tax records and certified statements shall be in such form and substance as to meet the requirements of the N.C. State Department of Revenue in the matter of the Owner obtaining a refund from the State of North Carolina of sales taxes paid by Contractor and his Subcontractors.

SC-6.12. Record Documents. Add the following to paragraph 6.12.A:

Refer to Submittals for detailed requirements concerning Record Documents.

SC-6.17. Shop Drawings and Samples. Add the following new paragraphs immediately after Paragraph 6.17.E:

- F. Contractor may furnish required submittals with sufficient information and accuracy in order to obtain required approval of an item with no more than three submittals. Engineer will record Engineer's time for reviewing subsequent submittals of Shop Drawings, samples, or other items requiring approval and Contractor shall reimburse Owner for Engineer's charges for such time.
- G. In the event that Contractor requests a change of a previously approved item, Contractor shall reimburse Owner for Engineer's charges for its review time unless the need for such change is beyond the control of Contractor.

SC-7.01. Related Work at Site. Add the following to paragraph 7.01.A:

Refer to the Section 01010 General Requirement for Work at the Site by CONTRACTORS, OWNER, and others.

SC-14.02.A. Applications for Payments. Add the following to paragraph 14.02.A.1.

Payment for stored materials and equipment will only be made for major items of materials or equipment. Payment for such materials and equipment shall be based only upon the actual cost of the materials and equipment to CONTRACTOR and shall not include any overhead or profit to CONTRACTOR. The CONTRACTOR shall include a cumulative monthly summary of all materials stored on site in the form shown below. As materials are entered into construction, the last column will be reduced correspondingly. The total of the last column will be paid as materials stored on site, less retainage.

| <u>Item No. From</u><br><u>Schedule of</u><br><u>Amounts</u> | <u>Description</u><br><u>of Material</u> | <u>Vendor &amp;</u><br><u>Invoice No.</u> | <u>Amount</u><br><u>of Invoice</u> | <u>Amount Stored,</u><br><u>Not Entered</u><br><u>Into Const.</u> |
|--|--|---|------------------------------------|---|
|--|--|---|------------------------------------|---|

The CONTRACTOR shall note the requirements for record drawings with each application for payment listed in the Specification section entitled SUBMITTALS.

SC-14.02.A.2. CONTRACTOR Affidavit. Add the following at the end of paragraph 14.02.A.2:  
The affidavit on each request for payments shall include the following:

The undersigned CONTRACTOR certifies that (1) all previous progress payments received from OWNER on account of Work done under the Contract referred to above have been applied on account to discharge CONTRACTOR's legitimate obligations incurred in connection with Work covered by prior Applications for Payment numbered 1 through \_\_\_\_\_ inclusive; (2) title of all Work, materials and equipment incorporated in said Work or otherwise listed in or covered by this Application for Payment will pass to OWNER at time of payment free and clear of all Liens, security interests and encumbrances (except such as are covered by a Bond acceptable to OWNER indemnifying OWNER against any such Lien, security interest or encumbrance); and (3) all Work covered by this Application for Payment is in accordance with the Contract Documents and not defective.

SC-14.05. Partial Utilization.

Add the following new paragraph 5 after 14.05.A.4.:

5. Such taking possession or use will not be deemed an acceptance of any Work not completed in accordance with the Contract Documents. OWNER's use of any facilities so identified in the Contract Documents will not be grounds for extension of the Contract Time or change in the Contract Price. OWNER's use of any facilities not specifically identified in the Contract Documents will be in accordance with conditions agreed to prior to such use, and any extra costs or delays in completion incurred and properly claimed by CONTRACTOR will be equitably adjusted with a Change Order.

END OF SUPPLEMENTARY CONDITIONS





# Work Change Directive

## No. 1

Date of Issuance: \_\_\_\_\_ Effective Date: \_\_\_\_\_

|                                       |  |                                  |
|---------------------------------------|--|----------------------------------|
| Project: Northside Commercial Center  | Owner: Greenville Utilities Commission | Owner's Contract No.:            |
| Contract: Sanitary Sewer Improvements |  | Date of Contract:                |
| Contractor:                           |  | Engineer's Project No.:<br>20049 |

**Contractor is directed to proceed promptly with the following change(s):**

| Item No. | Description |
|----------|-------------|
|          |             |
|          |             |
|          |             |

**Attachments (list documents supporting change):**

Refer to the attached exhibits describing the changes to reconstruct Milton Drive with 18" undercut excavation / select backfill; 8" CABG; 2" Asphalt.

**Purpose for Work Change Directive:**

Authorization for Work described herein to proceed on the basis of Cost of the Work due to:

- Nonagreement on pricing of proposed change.
- Necessity to expedite Work described herein prior to agreeing to changes on Contract Price and Contract Time.

**Estimated change in Contract Price and Contract Times:**

Contract Price \_\_\_\_\_ (increase/decrease)      Contract Time \_\_\_\_\_ (increase/decrease)  
days

|   |       |
|---|-------|
| Recommended for Approval by Engineer:       | Date  |
| Authorized for Owner by:                    | Date  |
| Received for Contractor by:                 | Date  |
| Received by Funding Agency (if applicable): | Date: |



# Change Order

No. \_\_\_\_\_

Date of Issuance: \_\_\_\_\_ Effective Date: \_\_\_\_\_

|                                       |  |                              |
|---------------------------------------|--|------------------------------|
| Project: Northside Commercial Center  | Owner: Greenville Utilities Commission | Owner's Contract No.:        |
| Contract: Sanitary Sewer Improvements |  | Date of Contract:            |
| Contractor:                           |  | Engineer's Project No.:20049 |

**The Contract Documents are modified as follows upon execution of this Change Order:**

Description:

**Attachments (list documents supporting change):**

**CHANGE IN CONTRACT PRICE:**

**CHANGE IN CONTRACT TIMES:**

Original Contract Price:

\$ \_\_\_\_\_

[Increase] [Decrease] from previously approved Change Orders No. \_\_\_\_\_ to No. \_\_\_\_\_

\$ \_\_\_\_\_

Contract Price prior to this Change Order:

\$ \_\_\_\_\_

[Increase] [Decrease] of this Change Order:

\$ \_\_\_\_\_

Contract Price incorporating this Change

\$ \_\_\_\_\_

Original Contract Times:  Working days  Calendar days

Substantial completion (days or date): \_\_\_\_\_

Ready for final payment (days or date): \_\_\_\_\_

[Increase] [Decrease] from previously approved Change Orders No. \_\_\_\_\_ to No. \_\_\_\_\_:

Substantial completion (days): \_\_\_\_\_

Ready for final payment (days): \_\_\_\_\_

Contract Times prior to this Change Order:

Substantial completion (days or date): \_\_\_\_\_

Ready for final payment (days or date): \_\_\_\_\_

[Increase] [Decrease] of this Change Order:

Substantial completion (days or date): \_\_\_\_\_

Ready for final payment (days or date): \_\_\_\_\_

Contract Times with all approved Change Orders:

Substantial completion (days or date): \_\_\_\_\_

Ready for final payment (days or date): \_\_\_\_\_

RECOMMENDED:

By: \_\_\_\_\_  
Engineer (Authorized Signature)

Date: \_\_\_\_\_

ACCEPTED:

By: \_\_\_\_\_  
Owner (Authorized Signature)

Date: \_\_\_\_\_

ACCEPTED:

By: \_\_\_\_\_  
Contractor (Authorized Signature)

Date: \_\_\_\_\_

# Change Order

## Instructions

### A. GENERAL INFORMATION

This document was developed to provide a uniform format for handling contract changes that affect Contract Price or Contract Times. Changes that have been initiated by a Work Change Directive must be incorporated into a subsequent Change Order if they affect Price or Times.

Changes that affect Contract Price or Contract Times should be promptly covered by a Change Order. The practice of accumulating Change Orders to reduce the administrative burden may lead to unnecessary disputes.

If Milestones have been listed in the Agreement, any effect of a Change Order thereon should be addressed.

For supplemental instructions and minor changes not involving a change in the Contract Price or Contract Times, a Field Order should be used.

### B. COMPLETING THE CHANGE ORDER FORM

Engineer normally initiates the form, including a description of the changes involved and attachments based upon documents and proposals submitted by Contractor, or requests from Owner, or both.

Once Engineer has completed and signed the form, all copies should be sent to Owner or Contractor for approval, depending on whether the Change Order is a true order to the Contractor or the formalization of a negotiated agreement for a previously performed change. After approval by one contracting party, all copies should be sent to the other party for approval. Engineer should make distribution of executed copies after approval by both parties.

If a change only applies to price or to times, cross out the part of the tabulation that does not apply.

# Field Order

No. \_\_\_\_\_

Date of Issuance: \_\_\_\_\_ Effective Date: \_\_\_\_\_

|             |        |                         |
|-------------|--------|-------------------------|
| Project:    | Owner: | Owner's Contract No.:   |
| Contract:   |        | Date of Contract:       |
| Contractor: |        | Engineer's Project No.: |

**Attention:**

You are hereby directed to promptly execute this Field Order issued in accordance with General Conditions Paragraph 9.04.A, for minor changes in the Work without changes in Contract Price or Contract Times. If you consider that a change in Contract Price or Contract Times is required, please notify the Engineer immediately and before proceeding with this Work.

Reference: \_\_\_\_\_ (Specification Section(s)) \_\_\_\_\_ (Drawing(s) / Detail(s))

Description:

---



---



---



---



---



---



---



---

Attachments:

---



---



---

|           |
|-----------|
| Engineer: |
|-----------|

|                                     |       |
|-------------------------------------|-------|
| Receipt Acknowledged by Contractor: | Date: |
|-------------------------------------|-------|

Copy to Owner



SECTION 01010 - PROJECT REQUIREMENTS

RELATED DOCUMENTS:

The general provisions of the Contract, including the General and Special Conditions and Division-1 Specification sections apply to work of this section.

GENERAL DESCRIPTION OF WORK:

The Work to be performed under these Contract Documents consists of

Construction and installation of utility improvements known as Grover Gaming - Sanitary Sewer Extension.

OTHER CONSTRUCTION CONTRACTS:

Work at the site performed by others under separate contracts includes the following:

None

RESPONSIBILITY FOR MATERIALS AND EQUIPMENT:

Items Furnished by CONTRACTOR: CONTRACTOR shall be fully responsible for all materials and equipment which he has furnished, and shall furnish necessary replacements at any time prior to expiration of the Guaranty Period.

OFF SITE STORAGE:

Off-site storage arrangements shall be acceptable to OWNER for all materials and equipment not incorporated into the work but included in Applications for Payment. Such off-site storage arrangements shall be presented in writing, and shall afford adequate and satisfactory security and protection. Off-site storage facilities shall be accessible to ENGINEER.

EQUIVALENT MATERIALS AND EQUIPMENT:

Whenever a material or article is specified or described by using the name of a propriety product or the name of a particular manufacturer or vendor without the words "or equal" or "or approved equal" etc., the specified item mentioned shall be provided. Other manufacturers' products will not be accepted.

It is the intent of these specifications to insure that materials and equipment of the highest reliability are supplied. The design of the overall product and selection of materials and equipment included in these specifications have been based upon dimensions, structures, connection wiring, etc. required for the first manufacturer listed in every reference to a quality standard. If material or equipment of another manufacturer (including alternatives specifically referenced) is offered, the cost of any changes in structures, building, piping, wiring, etc., as well as any detailed drawings necessary to show such required changes, shall be borne by the CONTRACTOR with no additional cost to the Owner.

PREPARATION FOR SHIPMENT:

All materials shall be suitably packaged to facilitate handling and protection against damage during transit and storage. Painted surfaces shall be protected against impact, abrasion, discoloration and other damage. All painted surfaces which are damaged prior to acceptance of equipment shall be repainted to the satisfaction of ENGINEER.

Each item, package or bundle of material shall be tagged or marked as identified in the delivery schedule or on the Shop Drawings. Complete packing lists and bills of material shall be included with each shipment.

SALVAGE OF MATERIALS AND EQUIPMENT:

Existing materials and equipment removed and not reused as a part of the Work shall be property of Greenville Utilities Commission. In addition, CONTRACTOR shall deliver such items to Greenville Utilities Commission Operations Center.

Existing materials and equipment removed by CONTRACTOR shall not be reused in the Work except where so specified or indicated.



LAND FOR CONSTRUCTION PURPOSES:

CONTRACTOR will be permitted to use available land belonging to OWNER, on or near the site of the Work, for construction purposes and for the storage of materials and equipment. The location and extent of the areas so used shall be as indicated on the drawings or will be as follows:

CONTRACTOR shall immediately move stored material or equipment if any occasion arises, as determined by OWNER, requiring access to the storage area. Materials or equipment shall not be placed on the property of OWNER until OWNER has agreed to the location to be used for storage.

EASEMENTS AND RIGHTS-OF-WAY:

The easements and rights-of-way for the pipelines will be provided by OWNER. CONTRACTOR shall confine his construction operations within the limits indicated on the drawings, and shall use due care in placing construction tools, equipment, excavated materials and pipeline materials and supplies, so as to cause the least possible damage to property and interference with traffic.

On Private Property: Easements across private property are indicated on the drawings. CONTRACTOR shall set stakes to mark the boundaries of construction easement across private property. The stakes shall be protected and maintained until completion of construction and cleanup.

CONTRACTOR shall not enter for pipe delivery or occupy for any other purpose with men, tools, equipment, construction materials or with materials excavated from the pipe trench, any private property outside the designated construction easement boundaries without written permission from the owner and tenant of the property.

Whenever the easement is occupied by crops which will be damaged by construction operations, CONTRACTOR shall notify the owner and tenant sufficiently in advance so that the crops may be removed before excavation or trenching is started. CONTRACTOR shall be responsible for all damage to crops outside of the easement, and shall make satisfactory settlement for the damage directly with the property owner and tenant involved.

Where the line crosses fields which are leveled for irrigation or terraced, CONTRACTOR shall relevel irrigated fields and replace all terraces to their original or better condition, and to the satisfaction of the property owner and tenant involved.

Work Within Highway and Railroad Rights-of-Way: Permits shall be obtained by OWNER. All Work performed and all operations of CONTRACTOR, his employees or subcontractors, within the limits of railroad and highway rights-of-way, shall be in conformity with the requirements and be under

the control (through OWNER) of the railroad or highway authority owning, or having jurisdiction over and control of, the right-of-way in each case.

#### OPERATION OF EXISTING FACILITIES:

The existing water, sanitary sewer and storm drainage utilities must be kept in continuous operation throughout the construction period. No interruption will be permitted which adversely affects the degree of service provided. Provided permission is obtained from OWNER in advance, portions of the existing facilities may be taken out of service for short periods corresponding with periods of minimum service demands.

CONTRACTOR shall provide temporary facilities and make temporary modifications as necessary to keep the existing facilities in operation during the construction period.

#### NOTICES TO OWNERS AND AUTHORITIES:

CONTRACTOR shall, as provided in General Conditions, notify owners of adjacent property and utilities when prosecution of the Work may affect them.

When it is necessary to temporarily deny access by owners or tenants to their property, or when any utility service connection must be interrupted, CONTRACTOR shall give notices sufficiently in advance to enable the affected persons to provide for their needs. Notices shall conform to any applicable local ordinance and, whether delivered orally or in writing, shall include appropriate information concerning the interruption and instructions on how to limit their inconvenience.

Utilities and other concerned agencies shall be contacted at least 48 hours prior to cutting or closing streets or other traffic areas or excavating near underground utilities or pole lines.

CONTRACTOR shall contact N.C. ONE-CALL 72 hours prior to any excavation. Locations of existing utilities by N.C. ONE-CALL are good for only ten (10) days after the date of location.

#### LINES AND GRADES:

All Work shall be done to the lines, grades, and elevations shown on the drawings.

Basic horizontal and vertical control points have been or will be established or designated by ENGINEER on the Drawings. These points shall be used as datum for the Work. All additional field survey, layout and measurement Work shall be performed by CONTRACTOR (construction stakeout allowance) as a part of the Work.

CONTRACTOR shall provide an experienced surveyor, instrument man, competent assistants and such instruments, tools, stakes and other materials required to complete the survey, layout and measurement Work. In addition, CONTRACTOR shall furnish, without charge, competent surveyors from his force and such tools, stakes and other materials as ENGINEER may require in establishing or designating control points, in establishing construction easement boundaries or in checking survey, layout and measurement Work performed by CONTRACTOR.

CONTRACTOR shall keep ENGINEER informed, a reasonable time in advance, of the times and places at which he wishes to do Work, so that any checking deemed necessary by ENGINEER may be done with minimum inconvenience to ENGINEER and minimum delay to CONTRACTOR.

CONTRACTOR shall remove and reconstruct Work which is improperly located.

Construction staking shall be performed by a Registered Land Surveyor at least twenty-four hours and three hundred feet in advance of construction.

Construction staking shall be included at the following locations:

1. Along the centerline of proposed water lines or force mains, at all points of horizontal curvature and tangency and at maximum intervals of one hundred feet (100') in tangent sections and twenty-five feet (25') in curved sections.
2. In addition to (1) above, the COMMISSION reserves the right to require that the centerline of proposed water lines or force mains be marked by a continuous paint stripe where there is concern for the quality of work being provided.
3. At offsets out of the way of construction operations for each point on the centerline required by (1) above.
4. At all valves, fittings, hydrants, air release valves, cleanouts, water meters and other appurtenances. Such stakes shall have offsets out of the way of construction.
5. Hubs shall be provided for all pump station plot property or easement corners and at the wet well and valve vault locations.
6. Hubs shall be provided at all manhole locations. Each hub shall have a guard stake indicating the manhole number and station number and shall have an offset out of the way of construction.
7. CONTRACTOR shall stake the easement line location when requested to do so by the COMMISSION.

ALLOWANCES:

The Contract Price includes cash allowances for certain materials, equipment and portions of the Work as follows:

Allowances are shown in the Bid Form.

OWNER, in consultation with ENGINEER, shall select from supplies, samples, information or alternatives submitted by CONTRACTOR. Testing agency shall be selected by and work for the OWNER, but be paid by the CONTRACTOR out of the above allowance.

CONTRACTOR shall cause the Work to be done by materialmen, suppliers or Subcontractors and for amounts satisfactory to ENGINEER. The Contract Price will be adjusted by Change Order for any difference between CONTRACTOR's direct cost for the selected alternative and the cash allowance included in such price adjustments. The cost shall be the actual invoice cost including tax and shipping of items covered by the allowance. The CONTRACTOR shall include any costs for labor overhead and profit in other portions of his bid.

CONNECTIONS TO EXISTING FACILITIES:

Unless otherwise specified or indicated, CONTRACTOR shall make all necessary connections to existing facilities including structures, drain lines and utilities such as water, sewer, gas, telephone and electric. In each case, CONTRACTOR shall receive permission from OWNER or the owning utility prior to undertaking connections. CONTRACTOR shall protect facilities against deleterious substances and damage.

Connections to existing facilities which are in service shall be thoroughly planned in advance, and all required equipment, materials and labor shall be on hand at the time of undertaking the connections. Work shall proceed continuously (around the clock) if necessary to complete connections in the minimum time. Operation of valves or other appurtenances on existing utilities, when required, shall be by or under the direct supervision of the owning utility.

UNFAVORABLE CONSTRUCTION CONDITIONS:

During unfavorable weather, wet ground or other unsuitable construction conditions, the CONTRACTOR shall confine his operations to work which will not be affected adversely by such conditions. No portion of the Work shall be constructed under conditions which would affect adversely the quality or efficiency thereof, unless special means or precautions are taken by CONTRACTOR to perform the Work in a proper and satisfactory manner.

CUTTING AND PATCHING:

As provided in General Conditions, CONTRACTOR shall perform all cutting and patching required for the Work, and as may be necessary in connection with uncovering Work for inspection or for the correction of defective Work.

CONTRACTOR shall perform all cutting and patching required for the installation of improperly timed Work, to remove samples of installed materials for testing and to provide for alteration of existing facilities or the installation of new Work in existing construction.

Except when the cutting or removal of existing construction is specified or indicated, CONTRACTOR shall not undertake any cutting or demolition which may affect the structural stability of the Work or existing facilities without ENGINEER's concurrence.

CONTRACTOR shall provide all shoring, bracing, supports and protective devices necessary to safeguard all Work and existing facilities during cutting and patching operations.

Materials shall be cut and removed to the extent indicated on the drawings or as required to complete the Work. Materials shall be removed in a careful manner with no damage to adjacent facilities or materials. Materials which are not salvable shall be removed from the site by CONTRACTOR.

All Work and existing facilities affected by cutting operations shall be restored with new materials, or with salvaged materials acceptable to ENGINEER, to obtain a finished installation with the strength, appearance and functional capacity required. If necessary, entire surfaces shall be patched and refinished.

CLEANING UP:

CONTRACTOR shall keep the premises free at all times from accumulations of waste materials and rubbish. CONTRACTOR shall provide adequate trash receptacles about the site, and shall promptly empty the containers when filled.

Construction materials stored on the site shall be kept off the ground, neatly stacked, protected from rain and sun when required by the ENGINEER, and the area around the stored materials shall be kept free of trash, weeds and brush.

Construction materials, such as concrete forms and scaffolding shall be neatly stacked by CONTRACTOR when not in use. CONTRACTOR shall promptly remove splattered concrete, asphalt, oil, paint, corrosive liquids and cleaning solutions from surfaces to prevent marring or other damage.

Volatile wastes shall be properly stored in covered metal containers and removed daily.

Wastes shall not be buried or burned on the site or disposed of into storm drains, sanitary sewers, streams or waterways. All wastes shall be removed from the site and disposed of in a manner complying with local ordinances and antipollution laws.

Adequate cleanup shall be a condition for recommendation of progress payment applications.

#### APPLICABLE CODES:

References in the Contract Documents to local codes mean the North Carolina State Building Code and any applicable County or municipal codes.

Other standard codes which apply to the Work are designated in the specifications.

#### REFERENCE STANDARDS:

Reference to the standards of any technical society, organization or association, or to codes of local or state authorities, shall mean the latest standard, code, specification or tentative standard adopted and published at the date of receipt of bids, unless specifically stated otherwise.

#### ABBREVIATIONS AND SYMBOLS:

Abbreviations used in the Contract Documents are defined as follows:

|        |   |
|--------|---|
| AAMA   | Architectural Aluminum Manufacturers Association                          |
| AASHTO | American Association of State Highway and Transportation Officials        |
| ACI    | American Concrete Institute   |
| AFBMA  | Antifriction Bearing Manufacturers Association                            |
| AGA    | American Gas Association  |
| AGMA   | American Gear Manufacturers Association                                   |
| AISC   | American Institute of Steel Construction                                  |
| AISI   | American Iron and Steel Institute   |
| AMCA   | Air Moving and Conditioning Association                                   |
| ANSI   | American National Standards Institute                                     |
| APA    | American Plywood Association  |
| API    | American Petroleum Institute  |
| ASCE   | American Society of Civil Engineers                                       |
| ASHRAE | American Society of Heating, Refrigerating and Air Conditioning Engineers |

|          |   |
|----------|---|
| ASME     | American Society of Mechanical Engineer                           |
| ASSE     | American Society of Sanitary Engineering                          |
| ASTM     | American Society for Testing and Materials                        |
| AWG      | American Wire Gauge   |
| AWPA     | American Wood Products Association                                |
| AWS      | American Welding Society  |
| AWWA     | American Water Works Association                                  |
| CGA      | Compressed Gas Association, Inc.                                  |
| CISPI    | Cast Iron Soil Pipe Institute                                     |
| CRSI     | Concrete Reinforcing Steel Institute                              |
| CS       | Commercial Standard   |
| DENR     | Department of Environment and Natural Resources                   |
| DHI      | Door and Hardware Institute                                       |
| Fed Spec | Federal Specifications  |
| FGMA     | Flat Glass Marketing Association                                  |
| IBBM     | Iron Body, Bronze Mounted   |
| IEEE     | Institute Electrical and Electronics Engineers                    |
| IFI      | Industrial Fasteners Institute                                    |
| IPS      | Iron Pipe Size  |
| MIL      | Military Specification  |
| NAAMM    | National Association of Architectural Metals Manufacturers        |
| NCDOT    | North Carolina Department of Transportation                       |
| NEC      | National Electrical Code  |
| NEMA     | National Electrical Manufacturers Association                     |
| NFPA     | National Fire Protection Association                              |
| NPT      | National Pipe Thread  |
| NSPC     | National Standard Plumbing Code                                   |
| OSHA     | Occupational Safety and Health Administration                     |
| PCI      | Prestressed Concrete Institute                                    |
| PS       | Product Standard  |
| SAE      | Society of Automotive Engineers                                   |
| SCPRF    | Structural Clay Products Research Foundation                      |
| SMACNA   | Sheet Metal and Air Conditioning Contractors National Association |

|      |                                   |
|------|-----------------------------------|
| SPI  | Society of the Plastics Industry  |
| SSPC | Steel Structures Painting Council |
| UL   | Underwriters' Laboratories        |
| US   | U. S. Bureau of Standards         |
| USBR | U. S. Bureau of Reclamation       |

PRECONSTRUCTION CONFERENCE:

Prior to the commencement of Work at the site, a preconstruction conference will be held at a mutually agreed time and place. The conference shall be attended by:

CONTRACTOR and his superintendent

Principal Subcontractors

Representatives of principal suppliers and manufacturers as appropriate

ENGINEER and his Resident Project Representative

Representatives of OWNER

Governmental representatives as appropriate

Others as requested by CONTRACTOR, OWNER, or ENGINEER

Unless previously submitted to ENGINEER, CONTRACTOR shall bring to the conference a tentative schedule for each of the following:

Progress

Procurement

Values for progress payment purposes

Shop Drawings and other submittals

The purpose of the conference is to designate responsible personnel and establish a working relationship. Matters requiring coordination will be discussed and procedures for handling such matters established. The agenda will include:



CONTRACTOR's tentative construction schedules

Transmittal, review, and distribution of CONTRACTOR's submittals

Processing applications for payment

Maintaining record documents

Critical Work sequencing

Processing of Field Orders, Work Change Directives, and Change Orders

Use of premises, office and storage areas, security, housekeeping, working hours, and OWNER's needs

Major equipment deliveries and priorities

CONTRACTOR'S assignments for safety and first aid

ENGINEER will preside at the conference and will arrange for keeping the minutes and distributing the minutes to all persons in attendance.

PROGRESS MEETINGS:

CONTRACTORS shall attend regular progress meetings at least monthly and at other times as requested by ENGINEER or required by progress of the Work.

CONTRACTOR, ENGINEER, OWNER, and all subcontractors active on the site shall be represented at each meeting. CONTRACTORS may at their discretion request attendance by representatives of their suppliers, manufacturers and other subcontractors. Representatives at the progress meeting must be authorized to make decisions and to act on behalf of the organization they represent.

ENGINEER shall preside at the meetings and provide for keeping and distribution of the minutes. The purpose of the meetings will be to review the progress of the Work, maintain coordination of efforts, discuss changes in scheduling and resolve other problems which may develop.

The CONTRACTOR shall generate documentation to list and/or illustrate work/tasks begun or completed since the previous progress meeting, and work/tasks expected to begin or be completed in the next 30 days following the current progress meeting. Preliminary or draft versions of this documentation should be circulated among critical subcontractors, the ENGINEER, and the OWNER, at least two (2) days prior to the scheduled progress meeting, such that schedule

conflicts and other scheduling issues can be discussed during the progress meeting. CONTRACTOR shall provide sufficient copies of the documentation for distribution at the progress meeting.

OTHER MEETINGS AND CONFERENCES:

The OWNER and ENGINEER reserve the right to conduct other site meetings and conferences as necessary to monitor and facilitate the quality of the work and operation of the existing facility. Specific meetings and conferences have been outlined in individual specification sections. Other meetings and/or conferences may include, but not be limited to, pre-installation and pre-startup. These meetings and/or conferences shall be attended by the CONTRACTOR, the ENGINEER, the OWNER, critical subcontractors, regulatory officials (if necessary), and representatives of manufacturers and suppliers as deemed necessary.

END OF SECTION 01010

SECTION 01150 - PAYMENTRELATED DOCUMENTS:

The general provisions of the Contract, including the General, Special Conditions and Division-1 Specification sections apply to work of this section.

SCOPE:

This section covers methods of payment for items of Work under this Contract.

GENERAL:

The total Bid Price for each part of the Project shall cover all Work required by the Contract Documents. All costs in connection with the proper and successful completion of the Work, including furnishing all materials, equipment, supplies, and appurtenances; providing all construction plant, equipment, and tools; and performing all necessary labor and supervision to fully complete the Work, shall be included in the unit and lump sum prices bid. All Work not specifically set forth as a pay item in the Bid Form shall be considered a subsidiary obligation of Contractor and all costs in connection therewith shall be included in the prices bid.

ESTIMATED QUANTITIES:

Refer to GC 11.9 and SC 11.9 concerning estimated quantities.

Payment will be made or lump sum prices adjusted according to unit prices bid and as described below.

Base Bid: This item shall include labor, equipment and materials necessary to accomplish all work specified and shown on the plans (Including but not limited to construction stakeout, clearing & grubbing, demolition, excavation, earthwork, stone placement, dewatering, utility installation, general grading, erosion control, testing and incidentals). Payment shall be lump sum based upon the price shown in the Proposal.

Soil and Materials Testing Allowance: This item shall include an allowance as indicated in the Bid Form as herein established. Payment shall be for the actual amount invoiced by the Testing Company.

Septic System Investigation / Repair Allowance: This item shall include an allowance as indicated in the Bid Form as herein established. Payment shall be for the actual amount invoiced by the

Licensed Soil Scientist and /or Septic Contractor.

Undercut Excavation With Off-Site Disposal: This item includes the excavation and off-site disposal of materials as directed and approved by the Engineer. Payment for the allotted amount shall be included in the Base Bid. The unit price shown in the Proposal shall be used as an add/deduct for adjustment of costs, based upon the actual number of cubic yards of material used.

Select Borrow Excavation: This item includes the excavation, transportation and compaction of off-site select borrow material used in filling undercut areas as directed and approved by the Engineer. No additional compensation will be made for proof-rolling subgrade. Payment for the allotted amount shall be included in the Base Bid. The unit price shown in the Proposal shall be used as an add/deduct for adjustment of costs, based upon the actual number of cubic yards of material used.

Stabilization Stone: This item shall include all labor, equipment and material for the placement as #57 stone in trenches as directed and approved by the Engineer. No additional compensation will be made for the excavation and off site disposal of existing soils material. Payment shall be made by the ton of material according to the unit price as shown in the Bid Proposal.

Subsidiary Obligations: All work not specifically set forth as a pay item in the Bid Schedule shall be considered a subsidiary obligation of the Contractor and all costs in connection therewith shall be included in the prices bid. Subsidiary obligations include, but are not limited to: traffic control, work zone safety measures, temporary drainage provisions, dewatering, removal and off-site disposal of excess excavated materials and debris, removal and replacement of existing features.

END OF SECTION 01150

SECTION 01300 – SUBMITTALSPART 1 – GENERALRELATED DOCUMENTS:

The general provisions of the Contract, including the General and Special Conditions and Division-1 Specification sections apply to work of this section.

CONSTRUCTION SCHEDULE:

Before Work is started, CONTRACTOR for Contract of the project shall submit to ENGINEER for review a minimum of five copies of the schedule of the proposed construction operations. OWNER shall cooperate with CONTRACTOR in arrangements for continuity of service and operation of valves and other control facilities. The construction schedule shall indicate the sequence of the Work, the time of starting and completion of each part for the general contractor and all subcontractors, the installation date for each major item of equipment, and the time for making connections to existing piping, structures, or facilities, for water testing of below grade structures prior to backfilling operations, and time for testing and start of each part or piece of equipment.

The construction schedule shall be a comprehensive, fully developed, horizontal Gantt-Chart or bar-chart type schedule, and shall include sufficient detail to communicate and/or illustrate the construction progress for such items/tasks as listed above. At least one copy of the construction schedule shall be submitted on one sheet, large enough to show the entire schedule for the entire construction period.

At least every 90 days the schedule shall be revised as necessary to reflect changes in the progress of the Work. Reviewed and approved construction schedules which indicate one or more tasks more than 30 days behind schedule shall also be revised and submitted to review. These revised schedules shall include a progress report as described in this section.

Failure of the CONTRACTOR to provide acceptable, updated/revised construction schedules and required progress reports will be grounds for the ENGINEER to recommend the OWNER withhold a portion of requested partial payment.

OWNER may require CONTRACTOR to add to his plant, equipment, or construction forces, as well as increase the working hours, if operations fall behind schedule at any time during the construction period.

In preparation of the construction schedule, the CONTRACTOR shall coordinate the schedule with his subcontractors schedules, the schedule of values, submittals schedule, progress reports, schedule of payments, and other required schedules and reports.

The following requirements shall be taken into consideration in preparing the proposed schedule of construction operations:

Shop drawing submittal schedule, review time, and any revision and resubmittal time.

The CONTRACTOR shall allow ample time in the schedule for equipment / utilities testing, record drawing preparation and acceptance prior to final completion.

#### PROGRESS REPORTS:

A progress report shall be furnished to ENGINEER with each copy of the application for progress payment. If the Work falls behind schedule, CONTRACTOR shall submit additional progress reports at such intervals as ENGINEER may request.

Each progress report shall include sufficient narrative to describe current and anticipated delaying factors, their effect on the construction schedule, and proposed corrective actions. Any Work reported complete, but which is not readily apparent to ENGINEER, must be substantiated with satisfactory evidence.

#### SURVEY DATA:

All field books, notes, and other data developed by CONTRACTOR in performing surveys required as part of the Work shall be available to ENGINEER for examination throughout the construction period. All such data shall be submitted to ENGINEER with the other documentation required for final acceptance of the Work.

#### SHOP DRAWINGS, MATERIAL CERTIFICATES AND PRODUCT DATA:

Engineering data covering all equipment and fabricated materials which will become a permanent part of the Work under this contract shall be submitted to ENGINEER for review prior to installation.

Shop drawings are technical drawings and data that have been specially prepared for this project.

Material Certificates are notarized statements by an official of the supplier certifying that the materials meet the specifications and are used in lieu of or in addition to shop drawings and product data.

Product data includes standard printed information on manufactured products that has not been specially-prepared for this project.

These data shall include drawings and descriptive information in sufficient detail to show the kind, size, arrangement and operation of component materials and devices; the external connections, anchorages and supports required; performance characteristics; and dimensions needed for installation and correlation with other materials and equipment.

All submittals, regardless of origin, shall be stamped with the approval of CONTRACTOR and identified with the name and number of the Contract, CONTRACTOR's name, and references to applicable specification paragraphs and Contract Drawings. Each submittal shall indicate the intended use of the item in the Work. When catalog pages are submitted, applicable items shall be clearly identified. The current revision, issue number, and date shall be indicated on all drawings and other descriptive data.

CONTRACTOR's stamp of approval is a representation to OWNER and ENGINEER that CONTRACTOR accepts full responsibility for determining and verifying all quantities, dimensions, field construction criteria, materials, catalog numbers, and similar data, and that he has reviewed or coordinated each submittal with the requirements of the Work and the Contract Documents.

All deviations from the Contract Documents shall be identified on each submittal and shall be tabulated in CONTRACTOR's letter of transmittal. Such submittals shall, as pertinent to the deviation, indicate essential details of all changes proposed by CONTRACTOR (including modifications to other facilities that may be a result of the deviation) and all required piping and wiring diagrams.

CONTRACTOR shall accept full responsibility for the completeness of each submission, and, in the case of a resubmission, shall verify that all exceptions previously noted by ENGINEER have been taken into account. In the event that more than one resubmission is required because of failure of CONTRACTOR to account for exceptions previously noted, CONTRACTOR shall reimburse OWNER for the charges of ENGINEER for review of the additional resubmissions.

Any need for more than one resubmission, or any other delay in obtaining ENGINEER's review of submittals, will not entitle CONTRACTOR to extension of the Contract Time unless delay of the Work is directly caused by a change in the Work authorized by a Change Order or by failure of ENGINEER to return any submittal within 21 days after its receipt in ENGINEER's office.

ENGINEER's review of drawings and data submitted by CONTRACTOR will cover only general conformity to the drawings and specifications, external connections, and dimensions which affect the layout. ENGINEER's review does not indicate a thorough review of all dimensions, quantities, and details of the material, equipment, device, or item shown. ENGINEER's review of submittals shall not relieve CONTRACTOR from responsibility for errors, omissions, or deviations, nor responsibility for compliance with the Contract Documents.

Five copies of each drawing and necessary data shall be submitted to ENGINEER. ENGINEER will not accept submittals from anyone but CONTRACTOR. Submittals shall be consecutively numbered in direct sequence of submittal and without division by subcontracts or trades. Resubmittals shall bear the number of the first submittal followed by a letter (A, B, etc.,) to indicate the sequence of the resubmittal.

When the drawings and data are returned marked DISAPPROVED or RESUBMIT, the corrections shall be made as noted thereon and as instructed by ENGINEER and five corrected copies resubmitted.

When corrected copies are resubmitted, CONTRACTOR shall in writing direct specific attention to all revisions and shall list separately any revisions made other than those called for by ENGINEER on previous submissions.

When the drawings and data are returned marked APPROVED AS NOTED, APPROVED, or RECORD COPY, no additional copies need be furnished.

#### LAYOUT DATA:

CONTRACTOR shall keep neat and legible notes of measurements and calculations made by him in connection with the layout of the Work. Copies of such data shall be furnished to the ENGINEER for use in checking CONTRACTOR's layout as provided under Lines and Grades. All such data considered of value to OWNER will be transmitted to OWNER by ENGINEER with other records upon completion of the Work.

#### RECORD DRAWING:

CONTRACTOR shall keep one record copy of all specifications, drawings, addenda, modifications, and shop drawings at the site in good order and annotated to show all changes made during the construction process. These shall be available to the ENGINEER and shall be delivered to the ENGINEER upon completion of the project. Complete record drawings shall be submitted to the ENGINEER and then approved by the ENGINEER before final payment is approved.



Updated record drawings shall be submitted for all work that is covered up including piping and utility work within 30 days of the installation.

An updated record drawing shall be prepared by the CONTRACTOR and submitted to the ENGINEER as a condition for approval for any pay request which includes pay items for sanitary sewer or water items.

Annotations on the drawings shall include the exact location of each service stub in relation to the next lowest manhole and centerline of street. Lengths, sizes and types of materials for mains and services shall also be shown.

#### REPORTS:

#### DAILY REPORTS:

The CONTRACTOR'S Site Superintendent shall prepare and maintain, at the site, daily construction reports recording the following information concerning events at the Project site:

- List of subcontractors at Project site.
- Approximate count of personnel at Project site.
- Time of arrival and departure of testing agency representative.
- Equipment at Project site.
- Material deliveries.
- High and low temperatures and general weather conditions.
- Accidents.
- Meetings and significant decisions.
- Unusual events.
- Stoppages, delays, shortages, and losses.
- Emergency procedures.
- Orders and requests of authorities having jurisdiction.
- Change Orders, Field Orders, and/or Work Change Directives received and implemented.
- Services connected and disconnected.
- Equipment or system tests and startups.
- Work/tasks started and/or completed.
- Substantial Completions authorized.

These daily reports shall be made available to the Engineer, Owner, or the Resident Project Representative for examination. These reports, as with Record Drawings, shall be kept up-to-date and will be checked as a partial basis for approval of the Pay Request.

MATERIAL LOCATION REPORTS:

The CONTRACTOR'S Site Superintendent shall prepare and submit to the Resident Project Representative prior to review of the monthly pay request, a comprehensive list of materials delivered to and stored at the Project site. The list shall be cumulative, with item numbers corresponding to the Schedule of Values and the Stored Materials as outlined in the Supplementary Conditions, showing materials previously reported plus items recently delivered. Include with the list, items which are stored away from the Project site. Items stored at locations away from the site have to be approved by the Owner, as outlined in Section 01010 - Project Requirements. The CONTRACTOR shall prepare a maintenance schedule and log of maintenance activities for the individual stored materials. This schedule and log should be kept up-to-date for review by the RPR and OWNER.

The Contractor shall also submit to the RPR, a site map of the storage area, indicating the location of the stored materials, for confirmation of storage by the RPR during review of the Pay Request. The site map should be neat, legible, and of sufficient size to illustrate the location of the individual stored materials.

CLARIFICATION/INFORMATION REQUEST REPORTS:

The CONTRACTOR, in requesting clarification, information, and/or deviation, shall prepare and submit to the ENGINEER a Request for Information (RFI). The RFI should include a detailed description of the request, and in the case of a clarification or deviation, any proposed changes requested to complete the Work. Multiple RFI's should be sequentially numbered and dated to logically track the submittals.

END OF SECTION 01300

SECTION 01400 - QUALITY CONTROLPART 1 - GENERALRELATED DOCUMENTS:

The general provisions of the Contract; including the General and Special Conditions and Division-1 Specification sections apply to work of this section.

TESTING LABORATORY SERVICES:

All tests which require the services of a laboratory to determine compliance with the Contract Documents shall be performed by an independent commercial testing laboratory acceptable to ENGINEER. The laboratory shall be staffed with experienced technicians, properly equipped, and fully qualified to perform the tests in accordance with the specified standards.

Testing Laboratory Services for Materials Qualification: CONTRACTOR shall be responsible for all testing laboratory services in connection with concrete materials and mix designs, the design of asphalt mixtures, gradation tests for embedment, fill, and backfill materials, and all other tests and engineering data required for ENGINEER's review of materials and equipment proposed to be used in the Work. CONTRACTOR shall pay all costs for services for materials qualifications.

Testing Laboratory Services for Field Quality Control: The testing laboratory for field quality control shall be selected by and work for the OWNER but be paid for by the CONTRACTOR from the testing allowance. A copy of the Testing Laboratory's monthly invoices shall be submitted to the Engineer for review prior to being included in the Contractor's monthly pay request. All charges of testing laboratories for field quality control tests made in the field or laboratory on concrete, asphalt mixtures, moisture-density (Proctor) and relative density tests on embedment, fill, and backfill materials, in-place field density tests on embedments and fills, and other materials and equipment, during and after their incorporation in the Work shall be paid by CONTRACTOR out of the testing allowance as discussed in SECTION 01010. The CONTRACTOR shall be responsible for scheduling of testing agency for field quality control. To verify that equipment, materials, and installations conform to the requirements outlined in the contract documents, the CONTRACTOR shall also schedule such additional testing as deemed necessary by the ENGINEER. Testing due to failed tests and wasted time due to improper scheduling by the CONTRACTOR will be paid for by the CONTRACTOR, not out of the testing allowance. Field sampling and testing will be performed by the testing laboratory personnel, in the general manner indicated in the specifications, with minimum interference with construction operations. ENGINEER shall determine the exact time and location of field sampling and testing, and may require such

additional sampling and testing as necessary to determine that materials and equipment conform with data previously furnished by CONTRACTOR and with the Contract Documents.

Arrangements for delivery of samples and test specimens to the testing laboratory will be made by CONTRACTOR. The testing laboratory shall perform all laboratory tests within a reasonable time consistent with the specified standards and shall furnish a written report of each test.

CONTRACTOR shall furnish all sample materials and cooperate in the sampling and field testing activities, interrupting the Work when necessary. When sampling or testing activities are performed in the field by testing laboratory personnel, CONTRACTOR shall furnish personnel and facilities to assist in the activities.

OWNER shall not require the CONTRACTOR to retain any testing laboratory against which CONTRACTOR has reasonable objection, and if at any time during the construction process the services become unacceptable to CONTRACTOR, he may request in writing that such services be terminated. The request must be supported with evidence of improper testing. If ENGINEER and OWNER determine that sufficient cause exists, CONTRACTOR may terminate the services and engage a different testing laboratory.

Transmittal of Test Reports: Written reports of tests and engineering data furnished by CONTRACTOR for ENGINEER's review of materials and equipment proposed to be used in the Work shall be submitted as specified for Shop Drawings in Section 01300.

The testing laboratory will furnish four copies of a written report of each test performed by laboratory personnel in the field or laboratory. Three copies of each test report will be transmitted to the ENGINEER and one copy to CONTRACTOR within three days after each test is completed. Testing laboratory will provide Resident Inspector and CONTRACTOR copies of field reports and test results on a daily basis prior to leaving the site. Notify ENGINEER and CONTRACTOR immediately of failing test results.

END OF SECTION 01400

SECTION 01500 - TEMPORARY FACILITIESRELATED DOCUMENTS:

The general provisions of the Contract, including the General and Special Conditions and Division-1 Specification sections apply to work of this section.

OFFICE AT SITE OF WORK:

During the performance of this Contract, CONTRACTOR for each Contract shall maintain a suitable office at or near the site of the Work which shall be the headquarters of his representative authorized to receive drawings, instructions, or other communication or articles. Any communication given to the said representative or delivered at CONTRACTOR's office at the site of the Work in his absence shall be deemed to have been delivered to CONTRACTOR.

Copies of the drawings, specifications, and other contract documents shall be kept at CONTRACTOR's office at the site of the Work and available for use at all times.

WATER:

All water required for and in connection with the Work to be performed and for any specified tests of piping, equipment, devices, etc., or for any other use as may be required for proper completion of the Work shall be provided by and at the expense of CONTRACTOR. No separate payment for water used or required will be made and all costs in connection therewith shall be included in the Bid.

POWER:

CONTRACTOR shall provide all power for heating, lighting, operation of CONTRACTOR's plant or equipment, or for any other use by CONTRACTOR. Temporary heat and lighting shall be maintained until the work is accepted.

SANITARY FACILITIES:

CONTRACTOR under Contract shall furnish temporary sanitary facilities at the site, as provided herein, for the needs of all construction workers and others performing work or furnishing services on the Project.

Sanitary facilities shall be of reasonable capacity, properly maintained throughout the construction period, and obscured from public view to the greatest practical extent. If toilets of the chemically treated type are used, at least one toilet will be furnished for each 20 men. CONTRACTOR shall enforce the use of such sanitary facilities by all personnel at the site.

#### MAINTENANCE OF TRAFFIC:

CONTRACTOR shall conduct his work to interfere as little as possible with public travel, whether vehicular or pedestrian. Whenever it is necessary to cross, obstruct, or close roads, driveways and walks, whether public or private, CONTRACTOR shall provide and maintain suitable and safe bridges, detours, or other temporary expedients for the accommodation of public and private travel, and shall give reasonable notice to owners of private drives before interfering with them. Such maintenance of traffic will not be required when CONTRACTOR has obtained permission from the owner and tenant of private property, or from the authority having jurisdiction over public property involved, to obstruct traffic at the designated point.

In making open cut street crossings, CONTRACTOR shall not block more than one-half of the street at a time. Whenever possible, CONTRACTOR shall widen the shoulder on the opposite side to facilitate traffic flow. Temporary surfacing shall be provided as necessary on shoulders.

Temporary Bridges: CONTRACTOR shall construct substantial bridges at all points where it is necessary to maintain traffic across pipeline construction. Bridges in public streets, roads, and highways shall be acceptable to the authority having jurisdiction thereover. Bridges erected in private roads and driveways shall be adequate for the service to which they will be subjected. Bridges shall be provided with substantial guard rails and with suitably protected approaches. Foot bridges shall be not less than 4 feet wide, provided with handrails and uprights of dressed lumber. Bridges shall be maintained in place as long as the conditions of the Work require their use for safety of the public, except that when necessary for the proper prosecution of the Work in the immediate vicinity of a bridge, the bridge may be relocated or temporarily removed for such period as ENGINEER may permit.

Detours: Where required by the authority having jurisdiction thereover that traffic be maintained over any construction work in a public street, road, or highway, and the traffic cannot be maintained on the alignment of the original roadbed or pavement, CONTRACTOR shall, at his own expense, construct and maintain a detour around the construction work. Each detour shall include a bridge across the pipe trench and all necessary barricades, guard rails, approaches, lights, signals, signs, and other devices and precautions necessary for protection of the Work and safety of the public.

BARRICADES AND LIGHTS:

All streets, roads, highways, and other public thoroughfares which are closed to traffic shall be protected by effective barricades on which shall be placed acceptable warning signs. Barricades shall be located at the nearest intersecting public highway or street on each side of the blocked section.

All open trenches and other excavations shall have suitable barricades, signs, and lights to provide adequate protection to the public. Obstructions such as material piles and equipment shall be provided with similar warning signs and lights.

All barricades and obstructions shall be illuminated with warning lights from sunset to sunrise. Material storage and conduct of the Work on or alongside public streets and highways shall cause the minimum obstruction and inconvenience to the traveling public.

All barricades, signs, lights and other protective devices shall be installed and maintained in conformity with applicable statutory requirements and, where within railroad and highway rights-of-way, as required by the authority having jurisdiction thereover.

FENCES:

All existing fences affected by the Work shall be maintained by CONTRACTOR until completion of the Work. Fences which interfere with construction operations shall not be relocated or dismantled until written permission is obtained from the owner of the fence, and the period the fence may be left relocated or dismantled has been agreed upon. Where fences must be maintained across the construction easement, adequate gates shall be installed. Gates shall be kept closed and locked at all times when not in use.

On completion of the Work across any tract of land, CONTRACTOR shall restore all fences to their original or to a better condition and to their original location.

PROTECTION OF PUBLIC AND PRIVATE PROPERTY:

CONTRACTOR shall protect, shore, brace, support, and maintain all underground pipes, conduits, drains, and other underground construction uncovered or otherwise affected by his construction operations. All pavement, surfacing, driveways, curbs, walks, buildings, utility poles, guy wires, fences, and other surface structures affected by construction operations, together with all sod and shrubs in yards and parkings, shall be restored to their original condition. All replacements shall be made with new materials.

CONTRACTOR shall be responsible for all damage to streets, roads, highways, shoulders, ditches, embankments, culverts, bridges, and other public or private property, regardless of location or character, which may be caused by transporting equipment, materials, or men to or from the Work or any part or site thereof, whether by him or his Subcontractors. CONTRACTOR shall make satisfactory and acceptable arrangements with the owner of, or the agency or authority having jurisdiction over, the damaged property concerning its repair or replacement or payment of costs incurred in connection with the damage.

All fire hydrants and water control valves shall be kept free from obstruction and available for use at all times.

#### TREE AND PLANT PROTECTION:

All trees and other vegetation which must be removed to perform the Work shall be removed and disposed of by CONTRACTOR; however, no trees or cultured plants shall be unnecessarily removed unless their removal is indicated on the drawings. All trees and plants not removed shall be protected against injury from construction operations.

Trees considered by ENGINEER to have any significant effect on construction operations are indicated on the drawings and those which are to be preserved are so indicated.

CONTRACTOR shall take extra measures to protect trees designated to be preserved, such as erecting barricades, trimming to prevent damage from construction equipment, and installing pipe and other Work by means of hand excavation or tunneling methods. Such trees shall not be endangered by stockpiling excavated material or storing equipment against the trunk.

When the injury or removal of trees designated to be preserved cannot be avoided, or when removal and replacement is indicated on the drawings, each tree injured beyond repair or removed shall be replaced with a similar tree of the nearest size possible.

All trimming, repair, and replacement of trees and plants shall be performed by qualified nurserymen or horticulturists.

#### SECURITY:

CONTRACTOR shall be responsible for protection of the site, and all work, materials, equipment and existing facilities thereon, against vandals and other unauthorized persons.

No claim shall be made against OWNER by reason of any act of an employee or trespasser, and CONTRACTOR shall make good all damage to OWNER's property resulting from his failure to provide security measures as specified.



Security measures shall be at least equal to those usually provided by OWNER to protect his existing facilities during normal operation, but shall also include such additional security fencing, barricades, lighting, watchman services and other measures as required to protect the site.

ACCESS ROADS:

CONTRACTOR under Contract shall establish and maintain temporary access roads to various parts of the site as required to complete the Project. Such roads shall be available for the use of all others performing work or furnishing services in connection with the Project.

PARKING:

CONTRACTOR under Contract shall provide and maintain suitable parking areas for the use of all construction workers and others performing work or furnishing services in connection with the Project as required to avoid any need for parking personal vehicles where they may interfere with public traffic, OWNER's operations or construction activities.

TEMPORARY DRAINAGE PROVISIONS:

CONTRACTOR shall provide for the drainage of stormwater and such water as may be applied or discharged on the site in performance of the Work. Drainage facilities shall be adequate to prevent damage to the Work, the site, and adjacent property.

Existing drainage channels and conduits shall be cleaned, enlarged or supplemented as necessary to carry all increased runoff attributable to CONTRACTOR's operations. Dikes shall be constructed as necessary to divert increased runoff from entering adjacent property (except in natural channels), to protect OWNER's facilities and the Work, and to direct water to drainage channels or conduits. Ponding shall be provided as necessary to prevent downstream flooding.

END OF SECTION 01500



SECTION 01700 - PROJECT CLOSEOUT

PART 1 - GENERAL

RELATED DOCUMENTS:

The general provisions of the Contract, including the General and Special Conditions and Division-1 Specification sections apply to work of this section.

DESCRIPTION OF REQUIREMENTS:

Provisions of this section apply to the procedural requirements for the actual closeout of the Work, not to administrative matters such as final payment or the change over of insurance. Closeout requirements relate to both substantial and final completion of the Work; they also apply to individual portions of completed work as well as the total Work. Specific requirements contained in other sections have precedence over the general requirements contained in this section.

PROCEDURES AT SUBSTANTIAL COMPLETION:

Prerequisites: Comply with the General Conditions, Special Conditions and complete the following before requesting the ENGINEER's inspection of the work, or a designated portion of the Work, for certification of substantial completion.

Submit executed warranties, workmanship bonds, maintenance agreements, inspection certificates and similar required documentation for specific units of work, enabling OWNER's unrestricted occupancy and use.

Submit record drawing documentation, maintenance manuals, tools, spare parts, keys and similar operational items.

Complete final cleaning, and remove temporary facilities.

Inspection Procedures: Upon receipt of CONTRACTOR's request, ENGINEER will proceed with inspection or advise CONTRACTOR of prerequisites not fulfilled. Following initial inspection, ENGINEER will either prepare CERTIFICATE OF SUBSTANTIAL COMPLETION, or advise CONTRACTOR of work which must be performed prior to issuance of the CERTIFICATE OF SUBSTANTIAL COMPLETION. The ENGINEER will repeat the inspection when requested and assure

that the Work has been substantially completed. Results of the completed inspection will form the initial "punch-list" for final acceptance.

PROCEDURES AT FINAL ACCEPTANCE:

Reinspection Procedure: The ENGINEER will reinspect the Work upon receipt of the CONTRACTOR's notice that, except for those items whose completion has been delayed due to circumstances that are acceptable to the ENGINEER, the Work has been completed, including punch-list items from earlier inspections. Upon completion of reinspection, the ENGINEER will either recommend final acceptance and final payment, or will advise the CONTRACTOR of work not completed or obligations not fulfilled as required for final acceptance. If necessary, this procedure will be repeated.

RECORD DOCUMENTATION:

Record Drawings: Maintain at the construction site a complete set of prints of the Contract Drawings and shop drawings for record mark-up purposes throughout the Contract Time. Mark-up these drawings during the course of the work to show both changes and the actual installation, in sufficient detail to form a complete record for the OWNER's purposes. Give particular attention to work which will be concealed and difficult to measure and record at a later date, and work which may require servicing or replacement during the life of the project. Record Drawings shall show all field changes of dimension and detail, station number of all service laterals, wyes, and tees measured from the nearest downstream manhole and the lengths of all service lines.

END OF SECTION 01700

SECTION 02110 - SITE CLEARING

PART 1 - GENERAL

RELATED DOCUMENTS:

The drawings and general provisions of the Contract, including General and Special Conditions and, Division 1 - Specification Sections, apply to work of this section.

DESCRIPTION OF WORK:

The extent of site clearing is shown on the drawings.

Site clearing work includes, but is not limited to, the following:

Protection of existing trees, shrubs, and other vegetation designated to remain.

Removal of trees and other vegetation.

Clearing and grubbing.

Removing of above-grade improvements.

Removing of below-grade improvements.

Related Work Specified Elsewhere:

Trenching, Backfilling and Compaction: Section 02220

Erosion Control: Section 02910

JOB CONDITIONS:

Easements: The Owner has obtained easement across private properties for the construction of this project. The limits of those easements are shown on the Drawings.

Protection of Existing Improvements: Provide protections necessary to prevent damage to existing improvements not indicated to be removed.

Protect improvements on both adjoining properties and on the Owner's easements.

Restore damaged improvements to their original condition, as acceptable to parties having jurisdiction.

Protection of Existing Trees and Vegetation: Protect existing trees and other vegetation which is to remain in place, against unnecessary cutting, breaking or skinning of roots, skinning and bruising of bark, smothering of trees by stockpiling construction materials or excavated materials within drip line, excess foot or vehicular traffic, or parking of vehicles within drip line. Provide temporary guards to protect trees and vegetation to be left standing.

Provide protection for roots over 1 1/2" diameter cut during construction operations. Coat the cut faces with an emulsified asphalt, or other acceptable coating, formulated for use on damaged plant tissues. Temporarily cover exposed roots with wet burlap to prevent roots from drying out; cover with earth as soon as possible.

Repair or replace trees and vegetation damaged by construction operations, in a manner acceptable to the Engineer. Repair tree damage by a qualified tree surgeon.

Replace trees which cannot be repaired and restored to full- growth status, as determined by the tree surgeon.

Salvageable Improvements: Carefully remove items indicated to be salvaged, and store on the Owner's premises where indicated, unless otherwise directed.

## PART 2 - PRODUCTS

Not applicable

## PART 3 - EXECUTION

### SITE CLEARING:

General: Remove all vegetation and improvements within the clearing limits except items indicated to remain.

Clearing Permanent Easements in Wooded Areas: Clear the entire area within the limits of the permanent construction easements unless indicated otherwise. Remove all trees, brush, undergrowth and other material to permit the work to progress in an unobstructed manner.

Clearing Permanent Easements in Lawn Areas: Remove existing trees, shrubs and lawn only to the extent necessary to permit the work to progress in an unobstructed manner. Do not indiscriminately clear the vegetation.

Clearing Temporary Construction Easements: Clear the area within the limits of the temporary construction easements only to the extent necessary to accomplish the work.

Site Grubbing: Completely remove stumps, roots, and other debris protruding through the ground surface within the cleared areas.

Fill depressions caused by clearing and grubbing operations with satisfactory soil material, unless further excavation or earthwork is indicated.

Place fill material in horizontal layers not exceeding 6" loose depth, and thoroughly compact to a density equal to adjacent original ground.

DISPOSAL OF WASTE MATERIALS:

Dispose of waste materials at a properly permitted offsite location.

Burning on Site: Burning is not permitted on the site.

END OF SECTION 02110





SECTION 02220 - TRENCHING, BACKFILLING AND COMPACTIONPART 1 - GENERALRELATED DOCUMENTS:

The general provisions of the Contract, including the General and Special Conditions and Division-1 Specification sections apply to work of this section.

DESCRIPTION OF WORK:

This section covers excavation and trenching work and shall include the necessary clearing, grubbing, and preparation of the site; removal and disposal of all debris; excavation and trenching as required; the handling, storage, transportation, and disposal of all excavated material; all necessary sheeting, shoring, and protection work; preparation of subgrades; pumping and dewatering as necessary or required; protection of adjacent property; backfilling; pipe embedment; and other appurtenant work.

RELATED WORK SPECIFIED ELSEWHERE:

Gravity Sanitary Sewer System - Section 02737  
Pipe and Pipe Fittings - Section 15060

QUALITY ASSURANCE:

Codes and Standards: Perform excavation work in compliance with applicable requirements of governing authorities having jurisdiction.

Employ testing laboratory to perform soil testing and Inspection service for quality control testing during earthwork operations. The cost of testing and inspection shall be paid for out of the testing allowance as specified in Division-1.

SUBMITTALS:

Test Reports-Excavating: Submit following reports directly to Engineer from the testing services, with copy to Contractor:

Test reports on soil and embedment.

Field density test reports.

One optimum moisture-maximum density curve for each type of soil encountered.

JOB CONDITIONS:

Classification of Excavated Materials: No classification of excavated materials will be made. Excavation and trenching work shall include the removal and subsequent handling of all materials excavated or otherwise removed in performance of the contract work, regardless of the type, character, composition, or condition thereof.

Existing Utilities: Locate existing underground utilities in areas of work. If utilities are to remain in place, provide adequate means of support and protection during earthwork operations.

Should uncharted, or incorrectly charted, piping or other utilities be encountered during excavation, consult utility owner immediately for directions. Cooperate with Owner and utility companies in keeping respective services and facilities in operation. Repair damaged utilities to satisfaction of utility owner.

Do not interrupt existing utilities serving facilities occupied and used by Owner or others, during occupied hours, except when permitted in writing by Engineer and then only after acceptable temporary utility services have been provided.

Provide minimum of 48-hour notice to Engineer, and receive written notice to proceed before interrupting any utility.

Demolish and completely remove from site existing underground utilities indicated to be removed. Coordinate with utility companies for shut-off of services if lines are active.

Use of Explosives: The use of explosives is not permitted.

Protection of Persons and Property: Barricade open excavations occurring as part of this work and post with warning lights.

Operate warning lights as recommended by authorities having jurisdiction.

Protect structures, utilities, sidewalks, pavements, and other facilities from damage caused by settlement, lateral movement, undermining, washout and other hazards created by earthwork operations.

## PART 2 - PRODUCTS

### DEFINITIONS:

Satisfactory soil materials are defined as those complying with ASTM D 2487 soil classification groups GW, GP, GM, GC, SM, SW, and SP.

Unsatisfactory soil materials are defined as those complying with ASTM D 2487 soil classification groups ML, MH, CL, CH, SC, OL, OH and PT.

### GENERAL MATERIALS:

Clean Sand: Washed or natural sand with less than 10 percent by weight passing the No. 200 sieve.

Filter Cloth: Spun synthetic fiber, 10 oz/sy, burst strength 500 psi, vertical water flow 265 gpm/sf, Trevira 1135, Mirafi or equal.

Granular Fill (Embedment and Stabilization Material): Granular fill or embedment material shall be crushed rock or gravel, shall be free from dust, clay, or trash, and shall be #57 stone as defined in ASTM C 33.

Aggregate Base Course Material: Naturally or artificially graded mixture of natural or crushed gravel, crushed stone, crushed slag, natural or crushed sand as specified in NC DOT Standard Specifications for Roads and Structures Section 520 Type A.

Fill Material (Backfill): All material deposited in trenches shall be free from rocks or stones larger than 2 inches, brush, stumps, logs, roots, debris, and organic or other objectionable materials, and shall be wetted or dried as required and thoroughly mixed to ensure uniform moisture content.

Select Backfill: Job excavation or borrow material consisting of coarse sands and fine sands with not more than 15% by weight passing the No. 200 sieve. This does not include clays, silts, organic soils or any materials not acceptable as fill material. Select backfill must receive prior approval from the ENGINEER before use.

Groundwater Barrier: Barrier material shall meet ASTM D2487 soil classification GC, SC, CL, or ML-CL and shall be compacted to 95 percent of maximum density. Material may be finely divided suitable job excavated material, free from stones, organic matter and debris.

### PIPE EMBEDMENT:

Embedment materials both below and above the bottom of the pipe, classes of embedment to be used, and placement and compaction of embedment materials shall conform to the requirements shown on the drawings and to the following supplementary requirements.

Embedment materials shall contain no cinders or other material which may cause pipe corrosion.

Class B Bedding shall be used for all ABS Truss, PVC Truss pipelines and DIP sewer pipelines.

Class B bedding shall include granular embedment from 4" below the pipe to the springline and select backfill embedment at least 12" above the pipe as shown on the attached drawing.

Class C Bedding shall be used for all reinforced and nonreinforced concrete pipelines.

Class C bedding shall include granular fill from 4" below the pipe to 1/6 of the outside diameter of the pipe and backfill embedment to at least 12" above the top of the pipe.

Class D Bedding shall be used for all PVC (SDR 35) gravity sewer pipe.

Class D bedding shall include granular embedment from 4" below the pipe to the top of the pipe and at least 12" of select backfill embedment above that.

Class F Bedding shall be used for all ductile iron pipe and PVC waterlines.

Class F embedment shall include backfill material from the bottom of the pipe (and bell holes) to at least 12" above the pipe.

### PART 3 - EXECUTION

#### GENERAL REQUIREMENTS:

Excavation shall provide adequate working space and clearances for the work to be performed therein and for installation and removal of concrete forms. In no case shall excavation faces be undercut for extended footings.

Subgrade surfaces shall be clean and free of loose material of any kind when concrete is placed thereon.

Except where exterior surfaces are specified to be dampproofed, monolithic concrete manholes and other concrete structures, or parts thereof, which do not have footings that extend beyond the outside face of exterior walls, may be placed directly against excavation faces without the use of outer forms, provided that such faces are stable and also provided that a layer of polyethylene

film is placed between the earth and the concrete.

Excavations for manholes and similar structures constructed of masonry units shall have such horizontal dimensions that not less than 6 inches clearance is provided for outside plastering. Backfilling and construction of fills and embankments during freezing weather shall not be done except by permission of the Engineer. No backfill, fill, or embankment materials shall be installed on frozen surfaces, nor shall frozen materials, snow or ice be placed in any backfill, fill or embankment.

#### DEWATERING:

Dewatering equipment shall be provided to remove and dispose of all surface and ground water entering excavations, trenches, or other parts of the work. Each excavation shall be kept dry during subgrade preparation and continually thereafter until the structure to be built, or the pipe to be installed therein, is completed to the extent that no damage from hydrostatic pressure, flotation, or other cause will result.

All excavations for concrete structures or trenches which extend down to or below ground water shall be dewatered by lowering and keeping the ground water level beneath such excavations 12 inches or more below the bottom of the excavation.

Surface water shall be diverted or otherwise prevented from entering excavated areas or trenches to the greatest extent practicable without causing damage to adjacent property.

The Contractor shall be responsible for the condition of any pipe or conduit which he may use for drainage purposes, and all such pipe or conduit shall be left clean and free of sediment.

#### SHEETING AND SHORING:

Except where banks are cut back on a stable slope, excavation for structures and trenches shall be sheeted, braced, and shored as necessary to prevent caving or sliding.

#### STABILIZATION:

Subgrades for concrete structures and trench bottoms shall be firm, dense, and thoroughly compacted and consolidated; shall be free from mud and muck; and shall be sufficiently stable to remain firm and intact under the feet of the workmen.

Subgrades for concrete structures or trench bottoms which are otherwise solid, but which become mucky on top due to construction operations, shall be reinforced with crushed rock or gravel. The stabilizing material shall be spread and compacted to a depth of not more than 4

inches; if the required depth exceeds 4 inches, the material shall be furnished and installed as specified for granular fills. Not more than 1/2 inch depth of mud or muck shall be allowed to remain on stabilized trench bottoms when the pipe bedding material is placed thereon. The finished elevation of stabilizing subgrades shall not be above subgrade elevations indicated on the drawings.

#### EARTH FILLS AND EMBANKMENTS:

To the maximum extent available, excess suitable material obtained from structure and trench excavations shall be used for construction of fills and embankments. Additional material shall be provided as required or obtained from the borrow pits where indicated on the drawings. After preparation of the fill or embankment site, the subgrade shall be leveled and rolled so that surface materials of the subgrade will be compact and well bonded with the first layer of the fill or embankment.

Fills and embankments shall be constructed in horizontal layers not exceeding 8 inches in uncompacted thickness. Material deposited in piles or windrows by excavating and hauling equipment shall be spread and leveled prior to compaction. Each layer shall be thoroughly compacted to 95 percent of the maximum density at optimum moisture content as determined by ASTM D 698. If the material fails to meet the density specified, compaction methods shall be altered.

Wherever a trench passes through a fill or embankment, the fill or embankment material shall be placed and compacted to an elevation 12 inches above the top of the pipe before the trench is excavated.

#### EXCAVATION FOR STRUCTURES:

Conform to elevations and dimensions shown within a tolerance of plus or minus 0.10', and extending a sufficient distance from footings and foundations to permit placing and removal of concrete formwork, installation of services, other construction, and for inspection.

In excavation for footings and foundations, take care not to disturb bottom of excavation. Trim bottoms to required lines and grades to leave solid base to receive other work.

#### ROADWAY EXCAVATION:

Excavation for the roadways shall conform to the lines, grades, cross sections, and dimensions indicated on the drawings and shall include the excavation of all unsuitable material from the subgrade. The top 12" of subgrade shall be compacted to 100% maximum density. Each layer of backfill or fill material below top 12" shall be compacted to 95% maximum density as determined

by ASTM D 698. Subgrade shall conform to proposed line, grade and cross-section. This operation shall include any reshaping and wetting or drying required to obtain proper compaction. All soft or otherwise unsuitable material shall be removed and replaced with suitable material.

Limiting Trench Widths: Trenches shall be excavated to a width which will provide adequate working space and sidewall clearances for proper pipe installation, jointing, and embedment. However, the limiting trench widths from the bottom of the trench to an elevation one foot above the top of installed pipe, and the minimum permissible sidewall clearances between the installed pipe and each trench wall shall be as follows:

| <u>Nominal<br/>Pipe Size</u><br>(inches) | <u>Minimum<br/>Trench Width</u><br>(inches) | <u>Maximum<br/>Trench Width</u><br>(inches) |
|--|---|---|
| Less than 18                             | Pipe O.D. Plus 18                           | Pipe O.D. Plus 24                           |
| 18 through 30                            | Pipe O.D. Plus 24                           | Pipe O.D. Plus 30                           |
| 34 through 48                            | Pipe O.D. Plus 24                           | Pipe O.D. Plus 36                           |

Stipulated minimum sidewall clearances are not minimum average clearances but are minimum clear distances which will be required.

Cutting trench banks on slopes to reduce earth load to prevent sliding and caving shall be used in areas where the increased trench width will not interfere with surface features or encroach on right-of-way limits. Slopes shall not extend lower than one foot above the top of the pipe.

Unauthorized Trench Widths: Where, for any reason, the width of the lower portion of the trench, as excavated at any point, exceeds the maximum permitted in the foregoing tables, either pipe of adequate strength, special pipe embedment, or arch concrete encasement, as required by loading conditions and with the concurrence of the Engineer, shall be furnished and installed by and at the expense of the Contractor.

Mechanical Excavation: The use of mechanical equipment will not be permitted in locations where its operation would cause damage to trees, buildings, culverts, or other existing property, utilities, or structures above or below ground. In all such locations, hand excavating methods shall be used.

Mechanical equipment used for trench excavation shall be of a type, design, and construction, and shall be so operated that the rough trench excavation bottom elevation can be controlled, that uniform trench widths and vertical sidewalls are obtained at least from an elevation one foot above the top of the installed pipe to the bottom of the trench, and that trench alignment is such that pipe when accurately laid to specified alignment will be centered in the trench with adequate clearance between the pipe and sidewalls of the trench, Undercutting the trench sidewall to obtain clearance will not be permitted.

Cutting Concrete and Asphalt Surface Construction: Cuts in concrete and asphalt pavements shall be no larger than necessary to provide adequate working space for proper installation of pipe and

appurtenances. Cutting shall be started with a concrete saw in a manner which will provide a clean groove at least 2 inches deep along each side of the trench and along the perimeter of cuts for structures.

Concrete and asphalt pavement over trenches excavated for pipelines shall be removed so that a shoulder not less than 6 inches in width at any point is left between the cut edge of the pavement and the top edge of the trench. Trench width at the bottom shall not be greater than at the top and no undercutting will be permitted. Pavement cuts shall be made to and between straight or accurately marked curved lines which, unless otherwise required, shall be parallel to the centerline of the trench. Pavement removed for connections to existing lines or structures shall not be of greater extent than necessary for the installation. Where the trench parallels the length of concrete walks and the trench location is all or partially under the walk, the entire walk shall be removed and replaced. Where the trench crosses drives, walks, curbs, or other surface construction, the surface construction shall be removed and replaced between existing joints or between saw cuts as specified for pavement.

Excavation Below Pipe Subgrade: Where required, pipe trenches shall be excavated below the underside of the pipe, to provide for the installation of granular embedment.

Artificial Foundations in Trenches: Whenever unsuitable or unstable soil conditions which cannot be corrected by dewatering are encountered, trenches shall be excavated below grade and the trench bottom shall be brought to grade with suitable stabilization material. The use of stabilization material (stone) shall be approved by the Engineer's Representative prior to installation.

Bell Holes: Bell holes shall provide adequate clearance for tools and methods used in installing pipe. No part of any bell or coupling shall be in contact with the trench bottom, trench walls, or granular embedment when the pipe is jointed.

#### PIPE EMBEDMENT:

Placement and Compaction: Granular embedment material shall be spread and the surface graded to provide a uniform and continuous support beneath the pipe at all points between bell holes or pipe joints. It will be permissible to slightly disturb the finished subgrade surface by withdrawal of pipe slings or other lifting tackle.

After each pipe has been graded, aligned, and placed in final position on the bedding material or trench bottom and shoved home, sufficient pipe embedment material shall be deposited and compacted under and around each side of the pipe and back of the bell or end thereof to hold the pipe in proper position and alignment during subsequent pipe jointing and embedment operations.

Embedment material shall be deposited and compacted uniformly and simultaneously on each



side of the pipe to prevent lateral displacement.

Hand placed embedment shall be compacted to the top of the pipe in all areas where compacted backfill is specified.

Whenever crushed rock is used as embedment for 36 inch and larger pipe, the portion above the bottom of the pipe shall be vibrated with a mechanical probe type vibrator during placement to ensure that all spaces beneath the pipe are filled.

Ground Water Barrier: Continuity of embedment material shall be interrupted by low permeability ground water barriers to impede passage of water through the embedment. Ground water barriers for sewer lines shall be compacted soil around each manhole. Barriers for all other pipelines shall be compacted soil the full depth of granular material, the full trench width, approximately 4 feet long, and spaced not more than 400 feet apart.

#### TRENCH BACKFILL:

Compact top 12" of subgrade at 100% maximum density. Each layer of backfill or fill material below top 12" shall be compacted to 95% maximum density, in the following locations:

Where beneath pavements, surfacings, driveways, curbs, gutters, walks or other surface construction or structures.

Where in street, road, or highway shoulders.

Where beneath fills or embankments.

In established lawn areas.

In other areas the backfill shall be compacted to 95 percent or equal to existing.

Where the trench for one pipe passes beneath the trench for another pipe, backfill for the lower trench shall be compacted to the level of the bottom of the upper trench.

Job excavation material may be used for compacted backfill when the job excavated material is finely divided and free from debris, organic material, cinders or other corrosive material, and stones larger than 3 inches in greatest dimension. Masses of moist, stiff clay shall not be used. Each layer of material shall have the best practicable moisture content for satisfactory compaction. The material in each layer shall be wetted or dried as required and thoroughly mixed to ensure uniform moisture content and adequate compaction. Backfill materials shall be placed in uniform layers not exceeding 8 inches in uncompacted thickness. Increased layer thickness may be permitted for noncohesive material if the Contractor demonstrates to the satisfaction of the Engineer that the specified compacted density will be obtained.

The method of compaction and the equipment used shall be appropriate for the material to be compacted and shall not transmit damaging shocks to the pipe.

The top portion of backfill beneath established lawn areas shall be finished with not less than 4 inches of topsoil corresponding to, or better than, that underlying adjoining lawn areas.

#### STRUCTURE BACKFILL:

The quality and moisture content of materials for backfill around and outside of structures shall conform to the requirements for fill materials. Backfill materials shall be deposited in layers not to exceed 8 inches in uncompacted thickness and compacted to at least 100 percent of maximum density at optimum moisture content as determined by ASTM D 698. Compaction of structure backfill by rolling will be permitted provided the desired compaction is obtained and damage to the structure is prevented. Compaction of structure backfill by inundation with water will not be permitted. No backfill shall be deposited or compacted in water. Particular care shall be taken to compact structure backfill which will be beneath pipes, drives, roads, parking areas, walks, curbs, gutters, or other surface construction or structures. In addition, wherever a trench is to pass through structure backfill, the structure backfill shall be placed and compacted to an elevation not less than 12 inches above the top of pipe elevation before the trench is excavated. Compacted areas, in each case, shall be adequate to support the item to be constructed or placed thereon.

#### DRAINAGE MAINTENANCE:

Trenches across roadways, driveways, walks, or other trafficways adjacent to drainage ditches or water courses shall not be backfilled prior to completion of backfilling the trench on the upstream side of the trafficway, to prevent impounding water after the pipe has been laid. Bridges and other temporary structures required to maintain traffic across such unfilled trenches shall be constructed and maintained by the Contractor. Backfilling shall be done so that water will not accumulate in unfilled or partially filled trenches. All material deposited in roadway ditches or other water courses by the line of trench shall be removed immediately after backfilling is completed and the original section, grades, and contours of ditches or water courses shall be restored. Surface drainage shall not be obstructed longer than necessary.

#### DISPOSAL OF EXCESS EXCAVATED MATERIALS:

Except as otherwise permitted, all excess excavated materials shall be disposed of away from the site of the work.

Broken concrete and other debris resulting from pavement or sidewalk removal, excavated rock in excess of the amount permitted to be installed in trench backfill, debris encountered in excavation work, and other similar waste materials shall be disposed of away from the site of the

work.

For excavation in street rights-of-way, Contractor shall grade work area to within 0.1 foot  $\pm$  of proposed subgrade. For excavation in easements, excess excavation may be distributed within the easements, to a maximum depth of 6 inches above the original ground surface elevation at and across the trench and sloping uniformly each way.

All wasted material shall be carefully finished with a drag, blade machine, or other suitable tool to a smooth, uniform surface without obstructing drainage at any point. The disposal of waste and excess excavated materials, including hauling, handling, grading, and surfacing shall be a subsidiary obligation of the Contractor and no separate payment will be made therefore.

#### SETTLEMENT:

The Contractor shall be responsible for all settlement of backfill, fills, and embankments which may occur within the correction period stipulated in the General Conditions.

The Contractor shall make, or cause to be made, all repairs or replacements made necessary by settlement within 30 days after notice from the Engineer or Owner.

#### TESTS:

As stipulated in the quality control section, all tests required for preliminary review of materials shall be made by an acceptable independent testing laboratory at the expense of the Contractor. Two initial gradation tests shall be made for each type of embedment, fill, or backfill material and one additional gradation test shall be made for each additional 500 tons of each material. Moisture-density (Proctor) tests and relative density tests on the materials, and all in-place field density tests, shall be paid for out of the testing allowance.

END OF SECTION 02220



SECTION 02513 - BITUMINOUS CONCRETE PAVING

PART 1 - GENERAL

RELATED DOCUMENTS:

The general provisions of the Contract, including General and Special Conditions and Division-1 Specification sections apply to work of this section.

Related Work Specified Elsewhere:

Earthwork: Section 02200

Portland Cement Concrete Curb and Gutter: Section 02514

DESCRIPTION OF WORK:

The extent of work under this item includes the placement of aggregate base course and bituminous concrete pavement.

Bituminous concrete paving shall also mean bituminous paving, asphalt, or asphalt concrete as may be used in other sections of the specifications or drawings.

SUBMITTALS:

Material Certificates: Bituminous Concrete Paving:

Provide 2 copies of materials certificates signed by the material producer and the Contractor, and notarized, certifying that each material item complies with, or exceeds, specified requirements.

Job Mix Formula:

Provide 2 copies of the proposed job mix formula at least 15 days prior to beginning work. If this formula has not been previously approved by NCDOT for the type of pavement specified, Contractor shall, at his own expense take whatever measures are necessary in order to obtain said approval prior to beginning work or have a mix design prepared by an approved Testing Lab.

JOB CONDITIONS:

Weather Limitations: Construction operations shall be conducted in accordance with the weather limitations given in the applicable sections of "Standard Specifications for Roads and Structures" as issued by N. C. Department of Transportation. No asphalt concrete shall be placed when the ambient temperature is less than 40 degrees F in the shade away from artificial heat.

Grade Control: Establish and maintain required lines and elevations as necessary to match existing grades and/or proposed grades on the drawings.

PART 2 - PRODUCTSMATERIALS:

Aggregate for Aggregate Base Course: Aggregate meeting the requirements of Section 520, Paragraph (a) of "Standard Specifications for Roads and Structures" as issued by NCDOT

Bituminous Concrete Base Course: Materials meeting the requirements of Section 610 of "Standard Specifications for Road and Structures" as issued by NCDOT

Bituminous Concrete Surface Course: Materials meeting the requirements of Section 610 of "Standard Specifications for Road and Structures" as issued by NCDOT

PART 3 - EXECUTIONGENERAL:

Install the aggregate base course, bituminous concrete base course and bituminous surface course in accordance with the applicable provisions of "Standards Specifications for Roads and Structures" as issued by the North Carolina Department of Transportation, except as otherwise noted herein.

SUBGRADE:

Shape surface of areas under base course to line, grade and cross-section shown on drawings, with finish surface not more than 1/2" above or below the required subgrade elevation.

Patches in driveways and roadways shall be graded to depth required to match existing pavement or to provide minimum pavement specified.

AGGREGATE BASE COURSE:

Place base course material on prepared subgrade in layers of uniform thickness. Grade the base course evenly to thickness indicated on drawings and compact to 100%. AASHTO T 180.

Maintain a uniform surface on the base course until the placement of the bituminous surface course is complete.

Provide a proof rolling of the compacted aggregate base course with a heavy roller or loaded dump truck (+25 tons) in the presence of the Engineer's Representative and the City of Greenville's Representative. The proof rolling shall be covered by the wheels of the proof roller operating at a speed between 2- 1/2 and 3-1/2 miles per hour.

Any areas that rut or pump excessively shall be allowed to dry or shall be undercut and backfilled with select backfill or coarse aggregate base course as directed by the Engineer.

After undercut and backfill operations are complete, a final proof rolling of the undercut areas will be performed in the presence of the Engineer's Representative and the City of Greenville's Representative.

TACK COAT:

Tack coat shall be applied to contact surfaces of previously constructed asphalt or portland cement concrete and surfaces abutting or projecting into asphalt concrete pavement. All application of tack coat shall be in conformance with Section 605 of the N.C. Highway Specifications for Roads and Structures dated January 1, 1990.

Tack coat shall be uniformly applied at a rate 0.02 to 0.05 gallons per square yard. No more tack coat material shall be applied than can be covered with base, binder, or surface course during the following day's operations. No base, binder or surface mixture shall be deposited thereon until the tack coat has sufficiently cured to properly receive paving.

All exposed surfaces, not intended to contact paving, shall be protected sufficiently to prevent tack coat from being tracked or splattered on said surfaces. After the tack coat has been applied, it shall be protected until it has cured for a sufficient length of time to prevent it from being picked up by traffic.

PLACING BITUMINOUS CONCRETE PAVEMENT:

Place bituminous concrete pavement in as continuous an operation as possible. The Contractor shall spread the materials to uniform density and strike a smooth finish true to cross-section and free from inequalities. Spread mixture at minimum temperature of 225 degrees F. Place each

course in the required amounts, so that when compacted, they will conform to the indicated grade, cross section, and thickness.

Asphalt shall be put down in one or two courses, as required to meet NCDOT compaction requirements. Surface course on 36' wide streets shall be installed in 3 pulls.

Provide joints between old and new pavements and between successive days' work for continuous bond between adjoining work. Clean contact surfaces and apply tack coat.

Rolling: Begin rolling when bituminous concrete mixture will bear roller weight without excessive displacement. Repair surface defects with hot bituminous concrete material as rolling progresses. Cut out and patch defective areas and roll to blend with adjacent satisfactory paving. Continue rolling until maximum density is attained and roller marks eliminated.

Protect paving from damage and vehicular traffic until bituminous concrete mixture has cooled and attained its maximum degree of hardness.

#### FIELD QUALITY CONTROL:

General: Test the in-place bituminous concrete courses for compliance with requirements for thickness and surface smoothness. Repair or remove and replace unacceptable paving as directed by the Engineer.

Thickness: In-place compacted thickness will not be acceptable if exceeding following allowable variation from required thickness:

Course Aggregate Base Course: 1/2", plus or minus

Bituminous Concrete Course: 1/4", plus or minus.

Surface Smoothness: Test finished surface of each bituminous concrete course for smoothness, using 10' straightedge applied parallel with, and at right angles to centerline of paved area. Surfaces will not be acceptable if exceeding the following tolerances for smoothness:

Base Course Surface: 1/4".

Wearing Course Surface: 1/8".

Check surfaced areas at intervals as directed by the Engineer.

END OF SECTION 02513



SECTION 02737 - GRAVITY SANITARY SEWER SYSTEM

PART 1 - GENERAL

RELATED DOCUMENTS:

The general provisions of the Contract, including the General and Special Conditions and Division-1 Specification sections apply to work of this section.

DESCRIPTION OF WORK:

The extent of sanitary sewer system work is shown on the drawings.

Types of sanitary sewer facilities include the following:

- Collectors
- Service Laterals
- Manholes

Related Work Specified Elsewhere:

- Trenching, Backfilling and Compaction: Section 02220
- Concrete: Section 03305

QUALITY ASSURANCE:

Codes and Standards: Comply with applicable standards contained herein and with the requirements of Greenville Utilities Commission.

Testing and Inspection: Contractor shall provide all necessary equipment and materials and shall perform the visual inspections, air testing and infiltration testing of the system in conformance with the requirements of this section.

SUBMITTALS:

Material Certificates:

Provide materials' certificates for pipe and manholes.

Shop Drawings: Submit shop drawings and/or product data for all pipe and fittings, pipe gaskets, transitions, precast manholes, sewer brick, manhole covers and frames, and manhole steps.

Test Results: Provide three (3) copies of the Air Test Data Sheets signed by the Contractor and a Representative of Greenville Utilities Commission.

## PART 2 - MATERIALS

### SEWER MAIN:

ABS Composite Pipe: ABS pipe shall conform to the requirements of ASTM D2680, Standard Specification for Acrylonitrile - Butadiene-Styrene Composite pipe. Joints and fabricated fittings shall be chemically welded using a cement and primer recommended by the pipe manufacturer. The pipe shall be similar in all respects to Armco Truss Pipe as manufactured by Contech Construction Products, Inc. ABS pipe shall be supplied in 12.5 foot lengths.

Ductile Iron Pipe: All ductile iron pipe shall be manufactured in compliance with ANSI Standard A21.51 and shall be cement mortar lined in accordance with ANSI A 21.4. The exterior of the pipe shall have a one (1) mil bituminous coating in accordance with ANSI A21.51. The thickness class for ductile iron pipe shall be Class 50 with polyethylene encasement (polywrap) unless required otherwise by the Commission. Pipe shall be in nominal 18-20 foot laying lengths. The pipe joints for ductile iron pipe shall be "push-on" manufactured in accordance with ANSI 21.11. Where fittings are required, as in the installation of drop manholes, the fittings shall conform to the requirements of section 7.2.3 (water main fittings) of the GUC Design Manual.

Polyethylene Encasement: Polyethylene encasement shall be applied to all underground ductile iron pipe installations. Materials and installation procedures shall be in accordance with ANSI/AWNA C105/A21.5-88.

PVC Composite Pipe: PVC Composite Pipe shall conform to the requirements of ASTM D 2680, Standard Specification for Poly (Vinyl Chloride). Joints and fabricated fittings shall be elastomeric (gasket) joints and shall be assembled in accordance with the manufacturer's recommendations. Minimum cell class shall be 12454B. The pipe shall be similar in all respects to Armco Truss Pipe as manufactured by Contech Construction Products, Inc. PVC composite pipe shall be supplied in 12.5 foot lengths.

"Polyvinyl Chloride (PVC) Pipe" (8" - 15"): PVC pipe shall conform to the requirements of ASTM D3034 (SDR 35). Joints and fabricated fittings shall be elastomeric (gasket) joints and shall be assembled in accordance with the pipe manufacturer's recommendations and Specification D3212. Gaskets shall meet the requirements of ASTM F477. Minimum cell class shall be 12454B. PVC pipe shall be supplied in 13.0 foot lengths.

SERVICES:

Sewer Service Pipe: Sewer service pipe shall be Schedule 40 PVC- Drain, Waste and Vent (DWV) pipe in accordance with ASTM D2665 and ASTM D1785. Cleanouts shall be constructed of pipe and fittings that also meet the ASTM requirements for Schedule 40 PVC-DWV pipe. Cleanout caps shall be Charlotte 110 or Jones BP134CSK flush cap. Cleanouts in traffic or paved areas shall be installed with a sewer cleanout box set to finished grade as shown in the standard details.

Service Fittings: Service saddles for use with ABS composite sewers shall be ABS saddle wyes as manufactured by Contech Construction Products, Inc. or approved equal. Wyes shall be chemically welded using the manufacturer's recommended primer, cement, and stainless steel bands.

Service fittings for use on PVC Composite Pipe shall be PVC standard gasketed wyes manufactured or approved by the pipe manufacturer and shall conform to the requirements of ASTM D2680.

Service fittings for use on PVC (SDR 35) pipe shall be standard gasketed wyes manufactured or approved by the pipe manufacturer and shall conform to the requirements of ASTM D3034.

Service from ductile iron pipe less than 18" in diameter shall be provided by means of ductile iron wyes meeting the requirements for water main fittings as given in Section 7.2-3 of the GUC Design Manual.

Transition Coupling: Pipe material changes between manholes may be permitted provided there is not a substantial difference in inside diameters, a smooth uniform flow line is maintained, and a watertight rubber sleeve or mechanical coupler conforming to ASTM C-425 is used to make the transition. All metal hardware shall be stainless steel. Transition sleeves shall be manufactured by Fernco or Indiana Seal.

MANHOLES:

Manholes: Manholes with a depth of 6' or less shall be precast and have concentric cones and monolithic bottom sections, manholes greater than 6' shall be precast and have eccentric cones and monolithic bottom sections unless otherwise approved by the commission in writing. Manholes shall conform to ASTM C-478. Joints shall be watertight and conform to the ASTM C478 standard for section joints designed for cold applied sealing compound. The sealing compound shall be CPS-210 as manufactured by Concrete Products Supply Company or approved equal.

Flat top manholes for gravity sewers shall be used only when approved in writing on a case by case basis by the Commission. Manholes of depth less than four feet (4') as measured from the top of the ring and cover to the lowest pipe invert shall require special design considerations. Shop Drawings shall be submitted to the Commission for such manholes.

The minimum inside diameter of manholes shall be 4.0 feet. Larger manholes shall be required for gravity sewers twenty inches (20") in diameter and larger. See the Standard Details.

Manholes more than twelve feet (12') in depth, as measured from the top of the ring and cover to the lowest invert, or as measured from surrounding finished ground elevation at the manhole location to the lowest manhole invert, whichever is greater, shall have an integral precast extended base as shown in the Standard Details.

Points of exit and entry for all pipe including services shall be provided with flexible manhole sleeves and all stainless steel take up clamps in accordance with ASTM C-923. Points of entry for mains or services that are added after fabrication of the manhole shall be provided by coring and installation of a flexible sleeve. All pipes shall extend through the manhole walls a minimum of 2 inches. Manholes exceeding twenty-three feet in depth shall require a certification from the manufacturer that the flexible sleeves provided are capable of withstanding a hydrostatic pressure equal to the depth of the manhole installed.

Manholes with preformed invert channels and benches may be utilized. Preformed invert channels must conform with Section 4.2.6.5 of the Greenville Utilities Commission (GUC) Design Manual. Points of pipe exit and entry shall conform with Section 8.4.5 of the GUC Design Manual. Manholes with inverts that are field constructed shall be done in accordance with the Standard Details.

The elevation difference between the "invert in" and "invert out" of manholes shall be either < 0.5' or > 2.5'. Manholes having pipes entering at elevations > 2.5' above the outlet shall be provided with an outside drop inlet according to the detail shown on the plans, if applicable.

Manhole rings and covers shall be manufactured in the USA of Class 30, gray cast iron conforming to the requirements of ASTM-A48 (latest revision thereof). The manufacturer's name and part number shall be cast into each component and the words "Sanitary Sewer" shall be cast into the cover. Pick holes shall be of the non-penetrating type. Bearing surfaces of both ring and cover shall be machined to insure proper fit and to prevent rattling.

#### **APPROVED MANHOLE RING AND COVERS**

|             | Model No.                    | Manufacturer                          |
|-------------|------------------------------|---------------------------------------|
| Standard    | V-1384                       | East Jordan Iron Works/Vulcan Foundry |
|             | USF 669 Frame & KL Cover     | US Foundry                            |
| Low Profile | V-1384-3                     | East Jordan Iron Works/Vulcan Foundry |
|             | USF 664 Frame & KL Cover     | US Foundry                            |
| Watertight  | 202701                       | East Jordan Iron Works/Vulcan Foundry |
|             | USF 710 Frame & LJ-SSG Cover | US Foundry                            |

|         |                                  |                                       |
|---------|----------------------------------|---------------------------------------|
| Locking | 202704                           | East Jordan Iron Works/Vulcan Foundry |
|         | USF 710 Frame & LJ-SSG-LOC Cover | US Foundry                            |

Watertight units, when required to be lockable, covers shall contain a locking device comprised of a stainless steel pentagon head bolt locking device which functions in the manner of a quarter turn fastener, as a part of the cover. All castings shall meet industry standards in regard to appearance and tolerances for dimensions and weight. Castings do not have to be painted. Manhole tops shall be designed and constructed for an H-20 traffic loading.

Manhole steps shall be constructed of 1/2" Grade 60 steel bars with a plastic coating and shall meet Federal Specifications RR- F-621C. Maximum vertical step spacing shall be sixteen inches (16") on center and shall be centered over the outlet pipe of the manhole.

### PART 3 - EXECUTION

#### GENERAL:

Adherence to Standards and Instructions: All pipe shall be transported, handled, stored, and installed in keeping with applicable AWWA/ASTM standards and manufacturer's instructions for the particular pipe material involved.

Responsibility for Materials: During loading, transportation, unloading and storage, every precaution shall be taken to prevent damage to pipe, fittings, and accessories and to keep them free from dirt and foreign matter at all times. Particular care shall be taken to prevent damage to pipe and fitting linings and coatings. Pipe shall be protected during handling against impact shocks or free fall. Pipe shall be kept clean at all times, and no pipe shall be used in the work that does not conform to the appropriate specifications. ABS or PVC pipe shall be protected from ultra-violet rays and from warping in accordance with manufacturer's recommendations.

#### INSTALLATION:

Pipe Laying: Each joint of pipe shall be carefully examined before being laid. Defective pipe shall be clearly marked and placed aside. Defective pipe shall not be installed.

Provide proper facilities for lowering pipe into trenches.

Ensure that the pipe bedding is set at true line and grade and is in conformance with the specifications.

Pipe shall be laid true to line and grade as designated on the plans with ends abutting. Each joint shall be tested for exact position by use of grade rod and plummet or laser. Carefully center the

pipe so that when laid, they will form a sewer with a uniform invert. Ensure that when joining pipes of different wall thickness the inverts of the pipe joints form a smooth line.

Pipe having its grade or joint disturbed after laying shall be taken up, cleaned and relaid.

Pipe installed by use of laser shall be checked for proper grade with engineering level and grade rod at each manhole prior to continuing pipelaying operations. Additional checks every 50 feet may be required by the Engineer.

The Contractor shall not be allowed to skip any section of the pipe line and move further upgrade, except as special permission is granted by the Engineer, or when the Contractor has more than one complete pipe laying crew working on the project.

Truss pipe ends shall be sealed with solvent weld cement supplied by pipe manufacturer. Preparatory to making pipe joints, clean and dry all surfaces of the portion of the pipe to be jointed and all jointing materials. Provide ventilation when using solvent joints. Jointing materials shall be applied and installed in accordance with the manufacturers specifications and placed, fitted and adjusted in an acceptable manner.

Stone embedment shall be as indicated in Trenching, Backfilling, and Compaction Section 02220.

All pipe shall be laid so that markings are on top. All pipe in place shall be inspected before being covered or concealed.

Keep trenches water-free and as dry as practicable during bedding, laying and jointing. Place sufficient backfill along each side of pipe as soon as practicable to brace pipe on line and grade.

Place a plastic stopper or other suitable device in the end of the last joint of pipe at the conclusion of each day's work or at other times when pipe laying is not in progress.

Prevent the entry of water, dirt, tools or other foreign matter into the pipe line.

When tying into existing sanitary sewer system, install temporary mechanical plug in closest downstream manhole. In an effort to keep dirt and debris from entering existing sanitary sewer system, plug shall remain in place from beginning through completion of project.

After pipe laying, inspect the interior pipe surfaces with lights held at each manhole. A full circle of light must be visible when viewed from the opposite ends of the line. Immediately adjust any deviation from true line and grade and repair all visible leaks. Take extra care to compact stone under pipe just outside of manhole to prevent settling of the pipe. Do not correct problems with minimum slope and drop through manholes by adjusting only the first joint in the manhole. Reverse grade and bellies in pipe will have to be repaired and replaced.

Service Lateral Installation: Service lateral locations where shown on the plans are approximate for estimates and bidding. Verify that service will be properly located for each adjoining residence. The service shall be installed in accordance with the details shown on the plans.

Ensure that bedding and backfill is installed in conformance with requirements of Trenching, Backfilling and Compaction Section 02220.

All joints shall be made in accordance with manufacturers recommendations. Ensure that the pipe is installed with at least a 1/8 inch per foot slope. Plug each service securely with a watertight plug.

Where services do not connect directly into a manhole, a service wye must be installed. All service pipe shall extend from the sewer main to the utility easement or right-of-way line unless directed otherwise by the ENGINEER.

All services shall have a clean-out installed at the easement or right-of-way line as shown on the plan details, or at a location directed by the Engineer. Clean-out shall consist of a wye fitting, bend, pipe, and cap or plug, all of the same material as the service pipe unless otherwise indicated.

Manholes: Construct manholes where shown on the plans and in accordance with the details.

Ensure that crushed aggregate bedding for manholes is properly installed and is true to line and grade. Set manhole base on bedding and verify conformance with line and grade as shown on the plans and that manhole is set plumb.

Pipe connection to existing manholes shall be made by machine coring such that the finished work will conform as nearly as practicable to the essential applicable requirements specified for new manholes, including all necessary concrete work, cutting and shaping.

Clean all joints and carefully inspect. Perform jointing in accordance with manufacturer's specifications. Insure a watertight seal at all joints.

Fill all interior and exterior joints, pinholes, lifting holes, and crevices with cement mortar to provide smooth surface. Fill all lifting holes and other holes through manhole with nonshrinking nonmetallic grout. Repair all air or water leaks in manholes from outside of manhole unless otherwise approved by the ENGINEER.

Accurately shape the inverts to a smooth semi-circle conforming to the inside contour of the adjacent sewer sections. All entering branches and changes in directions shall be formed by a circular curve in the invert of as large a radius as the size of manhole will permit. Changes in size and grade of the channels shall be made gradually and evenly. The invert channels shall be formed directly in the concrete of the manhole base, or shall be built up with brick and mortar. The floor of the manhole outside the channels shall be smooth and shall slope toward the channels not less than 1 inch per foot or more than 2 inches per foot.

Manhole steps shall be in vertical alignment and spaced uniformly approximately 16 inches apart.

Where drop manholes are indicated, or required they shall be constructed according to details shown on the plans.

Verify the elevation of ring and cover. Elevation of top should generally be as follows unless otherwise shown on plans:

Open fields and woodlands: 12" above grade.

Lawns and other mowed areas: 2" above grade.

Cultivated Fields: 6" above finished grade.

Paved Streets: Finished pavement grade.

Unpaved Streets: 4" below grade.

Where plans deviate from these dimensions, verify elevations with Engineer. Contractor shall adjust manholes to final grade at the time designated by the Engineer. No additional compensation will be made for manhole adjustment, except for existing manholes that require adjustment to finished street grade.

Secure manhole cover frame to manholes as outlined on the plans. Provide type of cover at each installation as indicated.

Separation From Water Mains: The sewer mains shall be laid at least 10 feet, horizontally, from any existing or proposed water main. Should local conditions prevent a lateral separation of 10 feet, a sewer may be laid closer than 10 feet to a water main if, the elevation of the top (crown) of the sewer is at least 18" below the bottom (invert) of the water main.

Whenever sewers must cross under water mains, the sewer shall be laid at such an elevation that the top of the sewer is at least 18" below the bottom of the water main. When the elevation of the sewer cannot be varied to meet the above requirements, then the sewer main shall be constructed of ferrous materials and with joints that are equivalent to water standards for a distance of ten (10) feet on each side of the crossing. The sewer main shall be pressure tested to assume watertightness prior to backfilling.

When it is impossible to obtain proper horizontal and vertical separation as stipulated above, both the water main and sewer shall be constructed of ductile iron pipe for 10 feet in each direction and shall be pressure tested to assure watertightness.

Connections of new sewers to existing manholes shall be accomplished by machine coring and the installation of a flexible connector meeting the requirements of Section 8.4-5 of the GUC Design Manual.



Dewater as necessary to provide a safe, clean work area.

Pipe joints with manholes shall be made with flexible manhole sleeves and all stainless steel take up clamps in accordance with ASTM C-923.

#### TESTING AND INSPECTION OF SYSTEM:

Testing and inspection shall promptly follow installation of wastewater pipe including services. Testing shall not be more than 1,000 feet behind wastewater pipe laying operation.

Furnish all pumps, gauges, instruments, test equipment and personnel required for inspection and testing operations.

All final testing and inspections shall be performed in the presence of the Resident Project Representative and a Representative of Greenville Utilities Commission.

Clean and pretest prior to notifying the Resident Project Representative and Greenville Utilities Commission's Representative and arranging for inspections and tests.

Inspect the system for conformance with line and grade shown on the plans and provide record drawing measurements per Section 01300 - Submittals. The maximum allowable drift between structures from proposed alignment is:

|                       |           |
|-----------------------|-----------|
| Horizontal alignment: | 0.20 foot |
| Vertical Grade:       | 0.05 foot |

Inspect the system for visible leaks (air or water). Repair all visible leaks. Correct all deviations from line and grade.

Materials removed to correct deficiencies revealed by tests and inspections shall not be reused. Pipe removed due to faulty grade shall be replaced with new pipe.

The following test sequence shall be included in the Contract Documents for all wastewater system extension unless otherwise permitted by the Commission.

1. Perform a visual inspection.
2. Correct defects revealed by visual inspection.
3. Perform leakage testing.
4. Make any necessary repairs.
5. Make the necessary retests.
6. Perform deflection testing (PVC SDR 35)

Visual Inspection For Gravity Sewers:

Gravity sewers shall be visually inspected from every manhole by use of mirrors, television cameras, or other devices. The lines shall appear circular in cross section with no noticeable deflection. Lines which do not meet specified tolerances or which have structural defects shall be replaced to meet the requirements of the Commission prior to leakage testing.

Deflection Testing for PVC (SDR 35) Gravity Sewers:

If PVC (SDR 35) sewer pipe is utilized, deflection testing shall be required with a rigid device (mandrel) sized to pass 5% or less deflection (or deformation) of the pipe.

Deflection test 100% of the total footage of solid wall PVC pipe.

The mandrel device shall be cylindrical in shape and constructed with nine or ten evenly spaced arms or prongs. Mandrels with less than nine arms will not be approved for use. The dimensions of the mandrel shall be as listed in the table below: The diameter of the mandrel shall carry a tolerance of plus or minus 0.01 inch.

| Nominal Diameter | Contact Length | Mandrel Diameter |
|------------------|----------------|------------------|
| 8"               | 8"             | 7.28"            |
| 10"              | 10"            | 9.08"            |
| 12"              | 12"            | 10.79"           |
| 15"              | 12"            | 13.20"           |
| 18"              | 15"            | 16.13"           |
| 21"              | 16"            | 19.00"           |
| 24"              | 17"            | 21.36"           |
| 27"              | 18"            | 24.06"           |

Allowance for piping wall thickness tolerances or ovality (from heat, shipping, poor production, etc.) shall not be deducted from the "D" dimension but shall be counted in as a part of the 5% or lesser deflection allowance.

The mandrel shall be hand pulled by the Contractor through all sewer lines in the presence of the Commission Representative, unless directed otherwise by the Commission. Any sections of the sewer not passing the mandrel shall be uncovered and the contractor shall repair the sewer to the satisfaction of the Commission. These repaired sections shall be retested.

Deflection testing shall be conducted no earlier than 30 days after reaching final trench backfill grade, provided in the opinion of the Commission that sufficient water densification or rainfall has occurred to thoroughly settle the soil throughout the entire trench depth. If this cannot be achieved in the time after installation prior to the project completion date, then the mandrel size shall be increased to measure 1/3 less of a deflection allowance.

Contact length shall be measured between points of contact of the mandrel arm. This length shall not be less than that shown in the table above.

The mandrel may not be used until approved by the Commission. Proving rings provided by contractor shall be used to assist in this. Drawings of the mandrel with complete dimensions shall be furnished by the Contractor to the Commission for each diameter and specification of pipe.

The mandrel device shall be as manufactured by H and H Fabricating of Fairfield, Ohio or Wortco, Inc. of Franklin, Ohio; and shall be approved by the Commission."

#### Leakage Testing For Gravity Sewers:

Unless otherwise permitted or required by the Commission, leakage testing for gravity sewers shall be by low pressure air test. Infiltration or exfiltration testing of the lines in lieu of air testing shall not be accepted without prior written approval of the Commission. All visible leaks shall be corrected regardless of the results of testing. All services, including those which discharge directly into manholes, shall be leakage tested.

#### Infiltration Test:

Infiltration testing shall be an acceptable test method only when the ground is fully saturated and the area is not subject to flooding. Immediately prior to performance of the line acceptance test, the groundwater level shall be determined by the same method used for the air test. The allowable infiltration rate shall be fifty (50) gallons per inch of pipe diameter, per mile of pipe, per twenty-four (24) hours.

#### Exfiltration Test:

The exfiltration test pressure shall be the greater of the following:

- (1) the maximum depth of the sewer test section as measured from the ground surface, plus the groundwater height above the lowest invert of the test section, or;
- (2) the 100 year flood elevation minus the lowest invert elevation of the test section, plus the ground water height above the lowest invert of the test section.

The exfiltration of the line shall not exceed fifty (50) gallons per inch of pipe diameter, per mile of pipe, per twenty-four (24) hours. The length of the test period shall be as required by the Commission, but in no case less than fifteen (15) minutes. Where a stream is not readily available as a source of water to use for testing, the Commission may agree to provide water. Proper procedures for requesting operation of valves and hydrants will be required.

Air Test: All air used for testing shall pass through a single, above ground control panel visible to the Commission's Representative during testing.

The Contract Documents shall require the groundwater elevation to be determined at 1000- foot intervals unless otherwise permitted or required by the Commission. Determination of groundwater elevation shall be made by vertically installing a six-inch diameter pipe beside the manhole such that the pipe extends into the stone bedding of the manhole. The test pressure shall be increased 0.43 psig per foot of groundwater head above the pipe invert.

The test pressure shall be 4.0 psig, plus the adjustment for groundwater. The air pressure shall be maintained for a minimum of two (2) minutes by throttling the air supply. The air supply shall then be disconnected and the pressure allowed to drop. At any convenient point at which internal air pressure is greater than 3.5 psig, (plus groundwater adjustment), timing shall commence with a stop watch or other timing device that is at least 99.8% accurate. The time required for the pressure to drop 1.0 psi shall be recorded.

The leakage rate shall be considered acceptable if the pressure does not drop over 1 psi in the time prescribed for the test as shown in the following table. Otherwise, the leakage rate shall be considered unacceptable.

The Contract Documents shall prohibit manhole entry during the test. The internal pressure on the system shall not exceed 9.0 psig.

Sewer service lengths shall be ignored for computing required test times for mains. In the event a test section, having a total surface area less than 625 square feet, fails to pass the air test when services have been ignored, the test time shall be recomputed to include all services using the following formula:

**MINIMUM TEST TIME FOR VARIOUS PIPE SIZES**

| 1<br>Pipe<br>Dia.<br>(inch) | 2<br>Minimum<br>Time<br>(min:sec) | 3<br>Max.<br>Length<br>For Min.<br>Time<br>(ft) | 4<br>Time<br>for<br>Longer<br>Length<br>(sec) | Specification Time for Length (L) Shown (min:sec) |        |        |        |        |        |        |        |
|-----------------------------|-----------------------------------|---|---|---|--------|--------|--------|--------|--------|--------|--------|
|                             |                                   |   |   | 100 ft  | 150 ft | 200 ft | 250 ft | 300 ft | 350 ft | 400 ft | 450 ft |
| 4                           | 3:46                              | 597   | .380 L  | 3:46  | 3:46   | 3:46   | 3:46   | 3:46   | 3:46   | 3:46   | 3:46   |
| 6                           | 5:40                              | 398   | .854 L  | 5 :40   | 5 :40  | 5 :40  | 5 :40  | 5 :40  | 5 :40  | 5:42   | 6:24   |
| 8                           | 7:34                              | 298   | 1.520 L                                       | 7:34  | 7:34   | 7:34   | 7:34   | 7:36   | 8:52   | 10:08  | 11:24  |
| 10                          | 9:26                              | 239   | 2.374 L                                       | 9:26  | 9:26   | 9:26   | 9:53   | 11:52  | 13:51  | 15:49  | 17:48  |
| 12                          | 11:20                             | 199   | 3.418 L                                       | 11:20   | 11:20  | 11:24  | 14:15  | 17:05  | 19:56  | 22:47  | 25:38  |
| 15                          | 14:10                             | 159   | 5.342 L                                       | 14:10   | 14:10  | 17:48  | 22:15  | 26:42  | 31:09  | 35:36  | 40:04  |
| 18                          | 17:00                             | 133   | 7.692 L                                       | 17:00   | 19:13  | 25:38  | 32:03  | 38:27  | 44:52  | 51:16  | 57:41  |
| 24                          | 22:40                             | 99  | 13.674 L                                      | 22:47   | 34:11  | 45:34  | 56:58  | 68:22  | 79:46  | 91:10  | 102:33 |

If service lateral sewers are included in the test section, their lengths may be ignored for computing the required test times. The test will be slightly more severe. In the event a test section, having a total surface area less than 625 square feet, fails to pass the air test when lateral sewers have been ignored, the test time shall be recomputed to include all lateral sewers using the following formula:

$$T = 0.085 \frac{(D1)(D1) L1+(D2)(D2)L2+...(Dn)(Dn) Ln K}{D1L1+D2L2+...DnLn Q}$$

Where T = Shortest allowable time, in seconds for the air pressure to drop 1.0 psig;

K = 0.000419 (D1L1+D2L2+...DnLn), but not less than 1.0"

Q = 0.0015 cu. ft./min./ sq. ft. of internal surface;

D1,D2,...Dn = Nominal Diameters of the different size being tested

L1,L2,...Ln = Respective Lengths of the different size pipes being tested.

If the recomputed test time is short enough to allow the section to pass, the section undergoing test shall have passed.

If the sections fail the air test, the Contractor shall determine at his own expense the source, or sources of leakage, and shall repair or replace all defective materials and workmanship.

No sealant shall be used in the newly installed sewers to correct the leaks without prior approval of the Engineer.

The extent and type of repair that may be allowed, shall be subject to the approval of the Engineer.

The repaired pipe installation shall be retested and required to meet the requirements of this test.

#### REPAIRS:

The Contractor may offer a maintenance fee in lieu of certain repairs to the system if approved by the Commission and Engineer. The maintenance fee will have to be agreed to by the Owner and Engineer.

END OF SECTION 02737



SECTION 02910 - EROSION AND POLLUTION CONTROLPART 1 - GENERALRELATED DOCUMENTS:

The general provisions of the Contract, including the General Conditions and Division-1 Specification sections apply to work of this section.

DESCRIPTION OF WORK:

The extent of the work required under this section is that required to minimize water, air, and noise pollution and soil erosion and siltation.

Temporary erosion control measures which may be necessary include, but are not limited to, temporary berms, dikes, dams, drainage ditches, silt basins, silt ditches, silt fences, rip rap, perimeter swales, slope drains, structures, vegetation, mulches, mats, netting, gravel or any other methods or devices that are necessary to control or restrict erosion. Temporary erosion control measures may include work outside the right-of-way or construction limits where such work is necessary as a result of construction such as borrow pit operations, haul roads, plant sites, equipment storage sites, and disposal of waste or debris. The Contractor shall be liable for all damages to public or private property caused by silting or slides originating in waste areas furnished by the Contractor.

Related Work Specified Elsewhere:

Fertilizing, Seeding and Mulching: Section 02920

QUALITY ASSURANCE:Codes and Standards:

North Carolina Sedimentation Pollution Control Act of 1973 and the Rules and Regulations promulgated pursuant to the provisions of said act.

City of Greenville Soil Erosion and Sedimentation Control Ordinance.

"Standard Specifications for Roads and Structures", North Carolina Department of Transportation (DOT).

In the event of conflict between the regulations listed above and the requirements of these specifications, the more restrictive requirement shall apply.

#### SANCTIONS:

Failure of the Contractor to fulfill any of the requirements of this section may result in the Owner ordering the stopping of construction operations in accordance with SUBARTICLE 13.8 of the General Conditions until such failure has been corrected. Such suspension of operations will not justify an extension of contract time nor additional compensation.

Failure on the part of the Contractor to perform the necessary measures to control erosion, siltations, and pollution will result in the Engineer notifying the Contractor to take such measures. In the event that the Contractor fails to perform such measures within 24 hours after receipt of such notice, the Owner may suspend the work as provided above, or may proceed to have such measures performed with other forces and equipment, or both. The cost of such work performed by other forces will be deducted from monies due the Contractor on his contract.

#### PART 2 - PRODUCTS

##### SILT FENCES:

Posts: Steel posts shall be 5' in height and be of the self-fastener angle steel type.

Posts shall be spaced at 8' max. when silt fence is backed with wire mesh, and 5' when no wire mesh is used or as required by the Engineer.

Woven Wire: Woven wire fencing shall conform to ASTM A116 for Class 3 galvanizing. Fabric shall be a minimum of 32" in width and shall have a minimum of 6 line wires with 12" stay spacing. The top and bottom wires shall be 10 gauge while the intermediate wires shall be 12-1/2 gauge. Wire fabric shall be fastened to posts with not less than #9 wire staples 1-1/2" long.

Fabric: Provide woven synthetic fiber designed specifically for silt fence conforming to NCDOT Standard Specifications for Roads and Structures Section 1056 Type 3 in Table 1056-1. Minimum roll width shall be 36".

##### DRAINAGE STONE:

NCDOT Class VI select material meeting the gradation requirements of standard size 57 in Table 1005-1 as described in Section 1005 and 1006.



RIP RAP:

Class B in accordance with NCDOT specifications.

FILTER CLOTH:

For use under rip rap provide geotextile which meets requirements of NCDOT Standard Specifications for Roads and Structures Section 1056 Type 2 in Table 1056-1.

MATTING FOR EROSION CONTROL:

Matting for erosion control shall be jute matting or excelsior matting. Other acceptable material manufactured especially for erosion control may be used when approved by the Engineer in writing before being used. Matting for erosion control shall not be dyed, bleached, or otherwise treated in a manner that will result in toxicity to vegetation.

TEMPORARY SEEDING:

Temporary seeding, when required, shall be performed in accordance with the recommendations contained in "Guide for Sediment Control on Construction Sites in North Carolina", published by the Soil Conservation Service and Section 02920 of these specifications.

PART 3 – EXECUTIONGENERAL:

The Contractor shall take whatever measures are necessary to minimize soil erosion and siltation, and water, air, and noise pollution caused by his operations. The Contractor shall also comply with the applicable regulations of all legally constituted authorities relating to pollution prevention and control. The Contractor shall keep himself fully informed of all such regulations which in any way affect the conduct of the work, and shall at all times observe and comply with all such regulations. In the event of conflict between such regulations and the requirements of the specifications, the more restrictive requirements shall apply.

EROSION AND SILTATION CONTROL:

The Contractor shall exercise every reasonable precaution throughout the life of the project to prevent the eroding of soil and the silting of rivers, streams, lakes, reservoirs, other water impoundments, ground surfaces, or other property.

Prior to suspension of operations on the project or any portion thereof, the Contractor shall take all necessary measures to protect the construction area, including but not limited to borrow sources, soil type base course sources, and waste areas, from erosion during the period of suspension.

Provide diversion ditches and berms as necessary to prevent concentrated flow of water across disturbed areas.

Stockpile excavated material on the opposite side of the utility trenches from the watercourses to the extent that is possible.

In the event that stockpiles are placed on the watercourse side of the trench, provide silt fence or silt berms with stone filter outlets along the entire length of the stockpile that is on the watercourse side of the trench. Upon the completion of backfilling, the measures shall be removed and the site graded to its natural grade or as shown on plans.

Maintain natural buffer zones along all watercourses sufficient to retain all visible siltation within the first 25 percent of the buffer width.

Provide a settling basin with a gravel filter outlet for all water pumped from trenches or dewatering equipment. Pumping of that water directly into any stream, pond, or watercourse is prohibited.

Tamp, fertilize, seed and mulch the disturbed areas as soon as practicable after line is installed and, in all cases, no later than 14 days after completion of the line segment or work at a particular site.

When construction operations are suspended for more than 14 days, provide temporary seeding and mulching of all disturbed areas including those areas in which further construction is necessary.

Erosion control measures installed by the Contractor shall be acceptably maintained by the Contractor.

Silt fences shall be provided where shown on the drawings and/or as necessary to prevent erosion.

Catch basins and Drop Inlets shall be protected from silt by placing rock inlet sediment traps around the openings until vegetative cover is established.

Temporary rock check dams shall be constructed where shown on the drawings.

Seeding for erosion control shall be performed in accordance with Section 02920.

Stream Or Ditch Crossings shall be performed in accordance with details shown on plans. Complete crossing in one working day. Carefully stabilize disturbed slopes by tamping with equipment buckets and mechanical or hand tamping. Distribute topsoil evenly on slopes and tamp.

Where rip rap is required, carefully place at least one foot thick over filter cloth.

Fertilize, seed, and mulch each crossing's slopes as soon as practicable after completing the crossing and in no case more than two weeks after disturbance of the slopes.

#### WATER AND AIR POLLUTION:

The Contractor shall exercise every reasonable precaution throughout the life of the project to prevent pollution of rivers, streams, and water impoundments. Pollutants such as chemicals, fuels, lubricants, bitumens, raw sewage, and other harmful waste shall not be discharged into or alongside of rivers, streams, or impoundments, or into natural or manmade channels leading thereto.

The Contractor shall comply with all State or local air pollution regulations throughout the life of the project.

#### DUST CONTROL:

The Contractor shall control dust throughout the life of the project within the project area and at all other areas affected by the construction of the project, including, but not specifically limited to, unpaved secondary roads, haul roads, access roads, disposal sites, borrow and material sources, and production sites. Dust control shall not be considered effective where the amount of dust creates a potential or actual unsafe condition, public nuisance, or condition endangering the value, utility, or appearance of any property.

#### NOISE CONTROL:

The Contractor shall exercise every reasonable precaution throughout the life of the project to prevent excessive and unnecessary noise. The Contractor shall choose his methods so as to minimize the disturbance of area residents.

END OF SECTION 02910

## SECTION 02920 - FERTILIZING, SEEDING AND MULCHING

### PART 1 - GENERAL

#### RELATED DOCUMENTS:

The general provisions of the Contract, including the General Conditions and Division-1 Specification sections apply to work of this section.

#### DESCRIPTION OF WORK:

Permanent Seeding: Permanent seeding is required for all areas disturbed by construction, except for areas covered by structures, pavements, etc.

Temporary Seeding: Soil stabilization shall be achieved on any area of a site where land-disturbing activities have temporarily or permanently ceased according to the following schedule:

1. All perimeter dikes, swales, ditches, perimeter slopes and all slopes steeper than 3 horizontal to 1 vertical (3:1) shall be provided temporary or permanent stabilization with ground cover as soon as practicable but in any event within 7 calendar days from the last land-disturbing activity.
2. All other disturbed areas shall be provided temporary or permanent stabilization with ground cover as soon as practicable but in any event within 14 calendar days from the last land-disturbing activity.
3. As deemed necessary by the Engineer.

The following conditions and/or exemptions shall apply in meeting the stabilization requirements above:

1. Extensions of time may be approved by the permitting authority based on weather or other site-specific conditions that make compliance impracticable.
2. All slopes 50' in length or greater shall apply the ground cover within 7 days except when the slope is flatter than 4:1. Slopes less than 50' shall apply ground cover within 14 days except when slopes are steeper than 3:1, the 7 day-requirement applies.
3. Any sloped area flatter than 4:1 shall be exempt from the 7-day ground cover requirement.
4. Slopes 10' or less in length shall be exempt from the 7-day ground cover requirement except when the slope is steeper than 2:1.
5. Although stabilization is usually specified as ground cover, other methods, such as chemical stabilization, may be allowed on a case-by-case basis.

6. For portions of projects within one mile and draining to trout waters and High Quality Waters as classified by the Environmental Management Commission, stabilization with ground cover shall be achieved as soon as practicable but in any event on all areas of the site within 7 calendar days from the last land-disturbing act.
7. For portions of projects located in Outstanding Resource Waters watersheds as classified by the Environmental Management Commission, stabilization with ground cover shall be achieved as soon as practicable but in any event on all areas within 7 calendar days from the last land-disturbing act.
8. Portions of a site that are lower in elevation than adjacent discharge locations and are not expected to discharge during construction may be exempt from the temporary ground cover requirements if identified on the approved E&SC plan or added by the permitting authority.

#### QUALITY ASSURANCE:

Codes and Standards: In general, follow procedures and guides published by the Soil Conservation Service, United States Department of Agriculture.

#### PART 2 - PRODUCTS

##### FERTILIZER:

Provide commercial fertilizer conforming to statutory requirements and all rules and regulations adopted by the North Carolina Board of Agriculture.

##### LIMESTONE:

Provide agricultural limestone conforming to all statutory requirements and all rules and regulations adopted by the North Carolina Board of Agriculture.

##### SEED:

Provide seed conforming to all statutory requirements and all rules and regulations adopted by the North Carolina Board of Agriculture.

Provide seed in accordance with requirements shown below. Deliver to site in original containers, labeled to show that the requirements of the N.C. Seed Law are met.

Quality of seed shall conform to the following:

| <u>Common Name</u> | <u>Minimum Seed Purity</u><br>% | <u>Minimum Germination</u><br>% | <u>Maximum Weed Seed</u><br>% |
|--------------------|---------------------------------|---------------------------------|-------------------------------|
|--------------------|---------------------------------|---------------------------------|-------------------------------|

Grasses

|                      |    |    |      |
|----------------------|----|----|------|
| Fescue Tall (KY.-31) | 98 | 90 | 1.00 |
| Common Bermudagrass  | 99 | 90 | 0.1  |
| Centipede            | 80 | 90 | 1.00 |
| Rye                  | 80 | 90 | 1.00 |

Seeding containing prohibited noxious weed seed shall not be accepted. Seed shall be in conformance with state seed law restrictions for restricted noxious weeds.

If seed of the accepted quality cannot be bought, secure prior approval before making changes or exceptions.

MULCH:

Mulch for erosion control shall consist of grain straw or other acceptable material, and shall have been approved by the Engineer before being used. All mulch shall be reasonably free from mature seedbearing stalks, roots, or bulblets of Johnson Grass, Nutgrass, Sandbur, Wild Garlic, Wild Onion, Bermuda Grass, Crotalaria, and Witchweed, and free of excessive amount of restricted noxious weeds as defined by the North Carolina Board of Agriculture at the time of use of the mulch. Also, there shall be compliance with all applicable State and Federal domestic plant quarantines. Straw mulch that is matted or lumpy shall be loosened and separated before being used.

Material for holding mulch in place shall be asphalt or other approved binding material applied in accordance with this section.

JUTE MESH:

Use jute mesh on seeded areas where slope is steeper than 2 horizontal to one vertical (2:1 slope). Use woven jute yarn weighing approximately 90 lbs. per 100 sq. yds. and having 3/4" openings.

### PART 3 - EXECUTION

#### GENERAL:

Follow procedures set forth in the publication "Guide for Sediment Control on Construction Sites in North Carolina" by the United States Department of Agriculture, Soil Conservation Service, and as specified herein.

Scarify soil to a depth of three (3) inches and work into a satisfactory seed bed by discing, use of cultipackers, harrows, drags and other approved means.

Preparation outlined above shall not be done when the soil is frozen, wet or otherwise in an unfavorable condition.

Begin and complete seeding operations as outlined below as soon as possible after final grading is completed, but in no event later than 30 days after completion of final grading.

Seeding and mulching operations shall not begin until electrical service has been installed within the project, unless directed by the Engineer.

Distribute lime and fertilizer, uniformly over seed bed and harrow, rake, or otherwise work same into seed bed.

Distribute seed uniformly over seed bed. Cover seed lightly after seeding.

No lime, fertilizer, or seed shall be applied during a strong wind, when soil is wet or otherwise unworkable. Should rain follow seeding before rolling is begun, the bed shall not be rolled.

#### PERMANENT SEEDING:

##### Application of Lime, Fertilizer and Seed:

Apply lime at the rate of 2 tons per acre.

Apply fertilizer at a rate and analysis which will provide the following amounts of nutrients:

Nitrogen: 100 pounds per acre  
Potash: 200 pounds per acre  
Phosphorous: 200 pounds per acre



Apply 600 pounds per acre of 20% superphosphate or equivalent in addition to that listed above or use an analysis which will provide the additional phosphorous.

Provide permanent seeding in accordance with the following schedule:

(January 1 – March 31)

|                                 |                      |
|---------------------------------|----------------------|
| Common Bermuda grass (unhulled) | - 20 pounds per acre |
| Rye (grain)                     | - 25 pounds per acre |

(April 1 – July 31)

|                               |                      |
|-------------------------------|----------------------|
| Common Bermuda grass (hulled) | - 15 pounds per acre |
| Weeping Lovegrass             | - 5 pounds per acre  |
| Centipede                     | - 8 pounds per acre  |

(August 1 – December 31)

|                                 |                      |
|---------------------------------|----------------------|
| Common Bermuda grass (unhulled) | - 20 pounds per acre |
| Tall Fescue                     | - 60 pounds per acre |
| Rye (grain)                     | - 25 pounds per acre |

Seed Bed Protection:

|              |                                |
|--------------|--------------------------------|
| Straw Mulch  | - 2 tons per acre (visual)     |
| Asphalt Tack | - 0.03 gallons per square yard |

#### TEMPORARY SEEDING:

Seed in accordance with Soil Conservation Service recommendations with regard to seed type, rate of application, fertilizer, etc.

#### APPLICATION OF MULCH:

Apply mulch immediately after permanent seeding at a uniform rate sufficient to achieve approximately 80% coverage of ground surface. Care must be taken to prevent the mulch from being applied too thickly and smothering the seedlings. Mulch for temporary seeding should be applied based upon the recommendations of the Soil Conservation Service for the particular type of seed to be used.

#### Mulch Anchoring:

On ground slopes less than 4%, anchor mulch with a straight blade disk or anchoring tool. Press mulch into soil about three inches. Operate equipment across slopes.

On ground slopes greater than 4%, apply asphalt with suitable applicator at a rate of not less than 150 gallons per ton of mulch.

Peg and twine anchoring may be used on steep slopes. Drive 8" wood stakes every 3 to 4 feet in all directions. Stretch in a crisscross and square in all directions. Secure twine around pegs and drive pegs flush with surface.

#### REPAIR AND MAINTENANCE:

Maintain the grass on the area for a period of 90 days after the grass growth appears. Reseed bare areas and repair all eroded areas during that period.

Repairs: Inspect all seeded areas and make necessary repairs or reseedings within the planting season, if possible. If stand should be over 60% damaged, reestablish following original lime, fertilizer and seeding recommendations.

All areas which do not exhibit satisfactory ground cover within 45 days of seed application shall be replanted.

END OF SECTION 02920

SECTION 03305 – CONCRETEPART 1 - GENERALRELATED DOCUMENTS:

Drawings and general provisions of the Contract, including General and Supplementary Conditions and Division - 1 Specification Sections apply to work of this section.

DESCRIPTION OF WORK:

Concrete work includes, but is not specifically limited to, concrete piers, pipe encasement, concrete curbs and gutters, concrete drives, walks and other concrete items required in the project.

RELATED ITEMS SPECIFIED ELSEWHERE:

Storm Sewer System: Section 02736

Gravity Sanitary Sewer System: Section 02737

Portland Cement Concrete Curb and Gutter: Section 02514

QUALITY ASSURANCE:

Codes and Standards: AC1 301 "Specifications for Structural Concrete for Buildings"; AC1 347 "Recommended Practice for Concrete Formwork", AC1 304 "Recommended Practice for Measuring, Mixing, Transporting, and Placing Concrete"; comply with applicable provisions except as otherwise indicated.

Workmanship: The Contractor is responsible for correction of concrete work which does not conform to the specified requirements, including strength, tolerances and finishes. Correct deficient concrete as directed by the Engineer.

Concrete Testing Service: Employ a testing laboratory acceptable to the Engineer to perform material evaluation tests and to design concrete mixes at Contractor's expense.

Certificates of material properties and compliance with specified requirements may be submitted in lieu of testing. Certificates of compliance must be signed by the materials producer and the Contractor.

## PART 2 - PRODUCTS

### CONCRETE MATERIALS:

Portland Cement: ASTM C150, Type 1, unless otherwise acceptable to the Engineer.

Aggregates: ASTM C33, except local aggregates of proven durability may be used when acceptable to the Engineer.

Water: Clean, potable.

Design strength: 3000 psi for sidewalks curb and gutter, drives, etc.; 3,000 PSI with 3/8" aggregate for masonry fill; 2500 psi for pipe blocking and encasement.

No admixtures containing calcium chloride may be used. Use Pozzolith by Master Builders, Plastiment or Plasticrete by Silka and Chemstrong A, R, or W by Castle Chemical Company or approved equal. Retarders and accelerators shall be used only as directed by the Engineer.

Air-Entraining Admixture: ASTM C260. Only use admixtures having neutralized vensol resins. Use MB-VR by Master Builders, SIKA AER by Sika Chemical Company, or CASTLE VR by Castle Chemical Company, or approved equal.

Use air-entraining admixture in all concrete, providing not less than 4% nor more than 6% entrained air.

Water-Reducing Admixture: ASTM C494, Type A, D, and E. Only use admixtures which have been tested and accepted in mix designs, unless otherwise acceptable.

Mortar: Mortar used for sewer structures shall conform to ASTM Specification C-144 as to aggregate and strength. Mortar shall be prepared from cement in perfect condition and shall be prepared in box for that purpose. No mortar that has stood beyond 45 minutes shall be used. Proportion by volume for different kinds of work shall be:

Brick Masonry 1 part cement to 2 parts sand

Jointing 1 part cement to 1 part sand

Concrete: Concrete shall be only plant-mixed or transit-mixed concrete conforming to ASTM C-94 for Ready-Mix Concrete.

FORM MATERIALS:

Provide form materials with sufficient stability to withstand pressure of placed concrete without bow or deflection.

Exposed Concrete Surfaces: Acceptable panel-type to provide continuous, straight, smooth, as-cast surfaces. Use largest practical sizes to minimize form joints.

Unexposed Concrete Surfaces: Suitable material to suit project conditions.

CURING COMPOUND:

Liquid membrane forming curing compound shall comply with ASTM C300, Type I Class A, minimum 22% solids.

REINFORCING MATERIALS:

Reinforcing Bars: ASTM A615, Grade 40

Welded Wire Fabric: ASTM A185

JOINT MATERIALS:

Self-Expanding Cork Joint Filler: Provide resilient and non-extruding type premolded cork units complying with ASTM D1752, Type III.

Water - Stop: PVC meeting Corps of Engineers CRD-C572 with center bulb.

PART 3 - EXECUTIONFORMING AND PLACING CONCRETE:

Ready-Mixed Concrete: ASTM C94. Furnish delivery tickets for each load showing amount of each material in the batch, time batched, date, job.

Formwork: Construct so that concrete members and structures are of correct size, shape, alignment, elevation and position, complying with ACI 347. Provide 3/4" chamfer on all exposed corners.

Provide openings in formwork to accommodate work of other trades. Accurately place and securely support items built into forms.

Clean and adjust forms prior to concrete placement. Apply form release agents or wet forms, as required. Retighten forms during and after concrete placement if required to eliminate mortar leaks.

Reinforcement: Position, support and secure reinforcement against displacement. Locate and support with metal chairs, runners, bolsters, spacers and hangers, as required. Set wire ties so ends are directed into concrete, not toward exposed concrete surfaces.

Install welded wire fabric in as long lengths as practicable, lapping at least one mesh.

Joints: Provide construction, expansion, weakened-plane (contraction), isolation, and control joints as indicated or required. Locate construction joints so as to not impair the strength and appearance of the structure. Place isolation and control joints in slabs-on-ground to stabilize differential settlement and random cracking.

Provide expansion and weakened-plane (contraction) joints where shown or required. Construct weakened-plane joints for a depth equal to at least 1/4 concrete thickness, either tooled, or with inserts unless otherwise shown. Tool edges of joints where slabs, walks, drives, curbs and gutters, etc. are constructed or replaced.

Place construction joints at the end of pours and at locations where placement operations are stopped for more than 1/2 hour, except where such pours terminate at expansion joints. Construct joints as shown or, if not shown, use standard metal keyway sections.

Provide premolded joint filler for expansion joints abutting curbs, manholes, and other fixed objects. Locate at 20' o.c. for pavement lanes unless otherwise specified.

Concrete Placement: Comply with ACI 304, placing concrete in a continuous operation within planned joints or sections. Do not begin placement until work of other trades affecting concrete is completed.

Consolidate placed concrete using mechanical vibrating equipment with hand rodding and tamping, so that concrete is worked around reinforcement and other embedded items and into all parts of forms.

Protect concrete from physical damage or reduced strength due to weather extremes during mixing, placement and curing.

In cold weather comply with ACI 306.

In hot weather comply with ACI 305.

CONCRETE FINISHES:

Exposed-to-view Surfaces: Provide a smooth rubbed finish for exposed formed concrete surfaces and surfaces that are to be covered with a coating or covering material applied directly to concrete. Remove fins and projects, patch defective areas with cement grout, and rub smooth.

Slab Trowel Finish: Apply trowel finish to interior monolithic slab surfaces that are exposed-to-view or are to be covered with resilient covering, paint or other thinfilm coating. Consolidate concrete surface by finish troweling, free of trowel marks, uniform in texture and appearance.

Curing: Begin initial curing as soon as free water has disappeared from exposed surfaces. Where possible, keep continuously moist for not less than 72 hours. Continue curing by use of moisture-retaining cover or membrane-forming curing compound. Apply curing compound according to manufacturer's instructions and Federal Specification TT-C-00800. Cure formed surfaces by moist curing until forms are removed. Provide protections as required to prevent damage to exposed concrete surfaces.

Drives, Walks, Curbs and gutter Finishing: After striking-off and consolidating, smooth the concrete surface by screeding and floating. Work edges of slabs, gutters, and other formed joints with an edging tool to a ½" radius. After floating and when excess moisture or surface sheen has disappeared, complete surface finishing as follows:

Broom finish by drawing a fine-hair broom perpendicular to line of traffic, as acceptable to the ENGINEER.

END OF SECTION 03305





# NORTHSIDE COMMERCIAL CENTER SANITARY SEWER EXTENSION CONSTRUCTION PLANS

Greenville Township, Pitt County, North Carolina

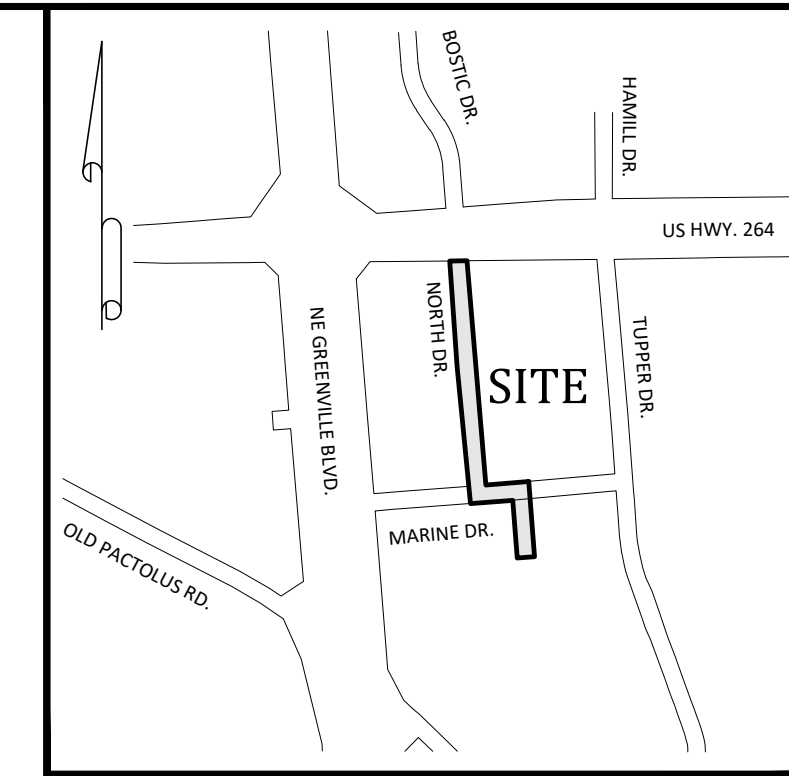

Vicinity Map  
NOT TO SCALE

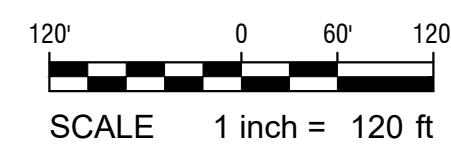

### SHEET INDEX

|               |                   |
|---------------|-------------------|
| Sheet No. C-1 | Cover Sheet       |
| Sheet No. C-2 | Plan and Profiles |
| Sheet No. C-3 | Plan and Profiles |
| Sheet No. C-4 | Details           |
| Sheet No. C-5 | Details           |

Survey 1 Sheet  
(Gary S. Miller and Associates, P.A. - Surveyor)

### Survey Note:

BOUNDARY AND TOPOGRAPHIC INFORMATION SHOWN HEREON WAS PREPARED BY GARY S. MILLER AND ASSOCIATES, P.A., AS SHOWN ON DRAWING ENTITLED BOUNDARY AND TOPOGRAPHICAL SURVEY FOR BLACKWELDER PROPERTIES, LLC, DATED OCTOBER 1, 2020, ATTACHED TO THIS DRAWING SET FOR REFERENCE.

SANITARY SEWER MAIN EXTENSION

**NORTHSIDE COMMERCIAL CENTER  
SANITARY SEWER EXTENSION**

Greenville Township, Pitt County, North Carolina

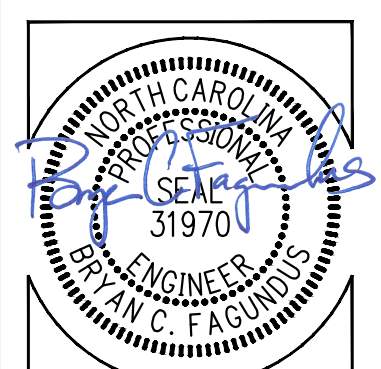

2/5/2021  
**ARK CONSULTING GROUP, PLLC**  
 ENGINEERS & PLANNERS  
 2755-B Charles Blvd.  
 Greenville, NC 27858  
 (252) 558-0888  
 www.arkconsultinggroup.com

Project Manager: BCF  
 Drawn By: EW  
 Checked By: STA  
 Project Number: 20049  
 Drawing Number: D-1244

**C-1**

Date: 12-07-2020

| # | DATE       | COMMENTS                                     |
|---|------------|--|
| 1 | 12/07/2021 | REVISED TO ADD SERVICES FOR PN 27852 & 42309 |

REVISIONS:



**Legend:**

|   |                 |
|---|-----------------|
| <b>EXISTING</b>                           | <b>PROPOSED</b> |
| ○ EIP - EXISTING IRON PIPE                |                 |
| ○ IPS - IRON PIPE SET                     |                 |
| ○ R/W - RIGHT OF WAY                      |                 |
| ○ B/B - BACK OF CURB TO BACK OF CURB      |                 |
| ○ L/P - LIGHT POLE                        |                 |
| ○ P/P - POWER POLE                        |                 |
| ○ G/W/S - GUY WIRES                       |                 |
| ○ C/B - CATCH BASIN                       |                 |
| ○ M/M - MANHOLE                           |                 |
| ○ S/S - SANITARY SEWER                    |                 |
| ○ RCP - REINFORCED CONCRETE PIPE          |                 |
| ○ P/L - PROPERTY LINE                     |                 |
| ○ U/G - UNDERGROUND                       |                 |
| ○ F/O - FIBER OPTIC WITNESS POST          |                 |
| ○ E/V - ELECTRIC VAULT                    |                 |
| ○ E/T - ELECTRIC TRANSFORMER              |                 |
| ○ E/T/S - ELECTRIC TRANSFORMERS           |                 |
| ○ E/M - ELECTRIC METER                    |                 |
| ○ T/P - TELEPHONE PEDestal                |                 |
| ○ F/H - FIRE HYDRANT                      |                 |
| ○ C/P - CABLE PEDESTAL                    |                 |
| ○ B/M - BENCHMARK                         |                 |
| ○ F/OV - FIBER OPTIC VAULT                |                 |
| ○ F/OWP - FIBER OPTIC WITNESS POST        |                 |
| ○ +314 - EXISTING SPOT ELEVATION          |                 |
| ○ C/O - SEWER CLEAN OUT                   |                 |
| ○ V/P - VENT PIPE                         |                 |
| ○ PVC - POLYVINYL CHLORIDE (PLASTIC) PIPE |                 |
| ○ - - - WATER MAIN                        |                 |
| ○ - - - CHAINLINK FENCE                   |                 |
| ○ - - - SANITARY SEWER (MAIN OR SERVICE)  |                 |
| ○ - - - SANITARY SEWER CLEANOUT           |                 |

**Stream Crossing Notes:**

- INSTALL TEMPORARY SAND BAG COFFERDAMS ON UPSTREAM AND DOWNSTREAM SIDES OF PIPE CROSSING WITHIN STREAM BED. ALTERNATIVE COFFERDAMS OR SHEET PILING MAY BE UTILIZED BY CONTRACTOR WHEN APPROVED BY ENGINEER. CONTRACTOR SHALL BE RESPONSIBLE FOR COFFERDAM DESIGN.
- CONTRACTOR IS RESPONSIBLE FOR DEWATERING WITHIN STREAM BED. SHOULD DEWATERING BE ACCOMPLISHED BY PUMPING, CONTRACTOR SHALL DISCHARGE PUMPED WATER THROUGH A SEDIMENT CONTROL BAG.
- SEDIMENT CONTROL BAGS SHALL BE LOCATED WITHIN LIMITS OF 30' UTILITY EASEMENT.
- CONTRACTOR SHALL PERMANENTLY SEED AND INSTALL TURF REINFORCEMENT MAT (ADS GEOSYNTHETICS PPS-10 TRM OR EQUAL) TO STABILIZE ALL DISTURBED AREAS WITHIN THE RIPARIAN BUFFER.

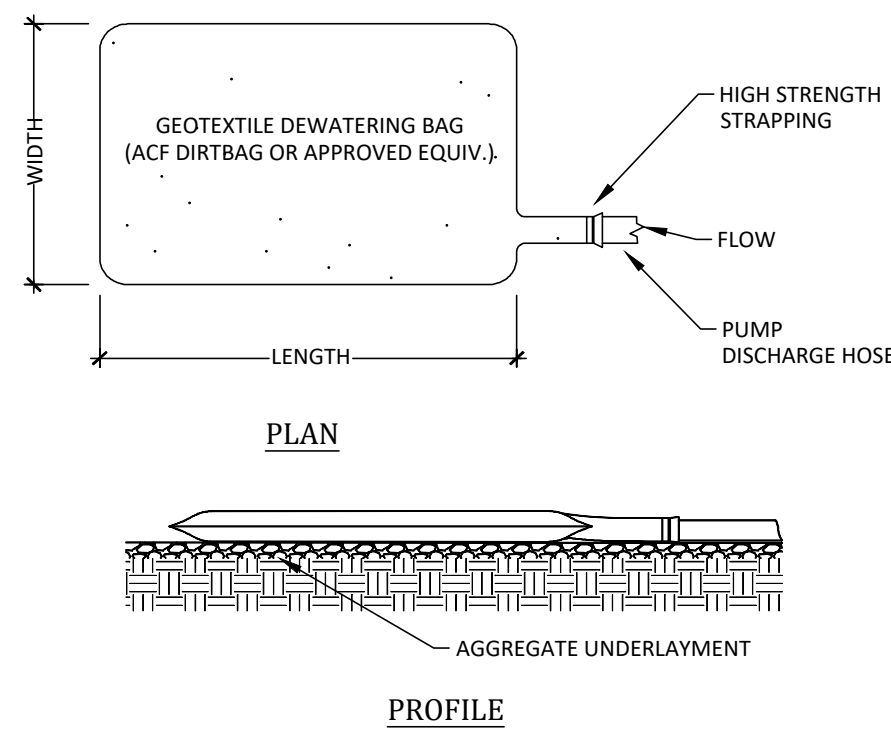
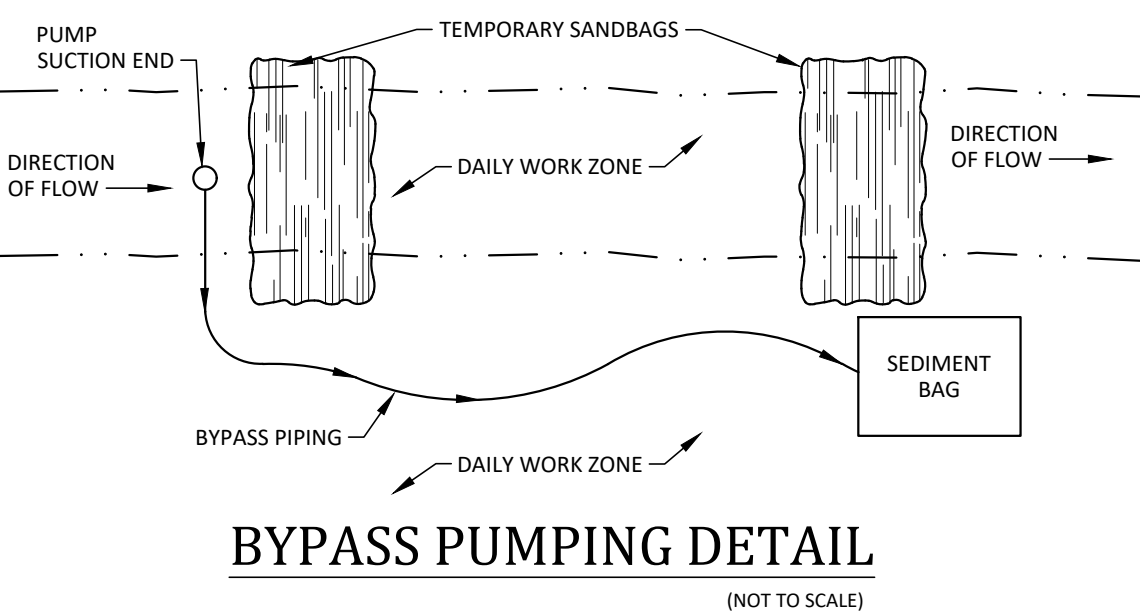

- NOTES:**
- THE DEWATERING BAG SHOULD BE PLACED SO THE INCOMING WATER FLOWS INTO AND THROUGH THE BAG, AND THEN FLOW OFF THE SITE WITHOUT CREATING MORE EROSION. THE NECK SHOULD BE TIED OFF TIGHTLY TO STOP THE WATER FROM FLOWING OUT OF THE BAG WITHOUT GOING THROUGH THE WALLS. THE DEWATERING BAG SHOULD BE PLACED ON A GRAVEL BED TO ALLOW WATER TO FLOW IN ALL DIRECTIONS.
  - THE DEWATERING BAG IS CONSIDERED FULL AND SHOULD BE DISPOSED WHEN IT IS IMPRACTICAL FOR THE BAG TO FILTER THE SEDIMENT OUT AT A REASONABLE FLOW RATE. AT THIS POINT, IT SHOULD BE REPLACED WITH A NEW BAG.
  - BAG SHALL BE DISPOSED OF IN A LEGAL MANNER.
- MATERIALS:**
- THE GEOTEXTILE FABRIC SHALL BE A TYPE GD-IV.
  - THE DEWATERING BAG SHALL BE SEWN WITH A DOUBLE NEEDLE MACHINE USING HIGH STRENGTH THREAD. ALL STRUCTURAL SEAMS WILL BE SEWN WITH HIGH STRENGTH, DOUBLE STITCHED "J" TYPE. SEAM STRENGTH TEST WILL HAVE THE FOLLOWING MINIMUM AVERAGE ROLL VALUES:

| TYPE       | TEST METHOD | TEST RESULT |
|------------|-------------|-------------|
| HEAVY DUTY | ASTM D-4884 | 100 LB/IN   |

- THE DEWATERING BAG SHALL HAVE AN OPENING LARGE ENOUGH TO ACCOMMODATE A FOUR (4) INCH DISCHARGE HOSE WITH ATTACHED STRAP TO TIE OFF THE HOSE TO PREVENT THE PUMPED WATER FROM ESCAPING FROM THE BAG WITHOUT BEING FILTERED.

**GEOTEXTILE DEWATERING BAG**  
NOT TO SCALE

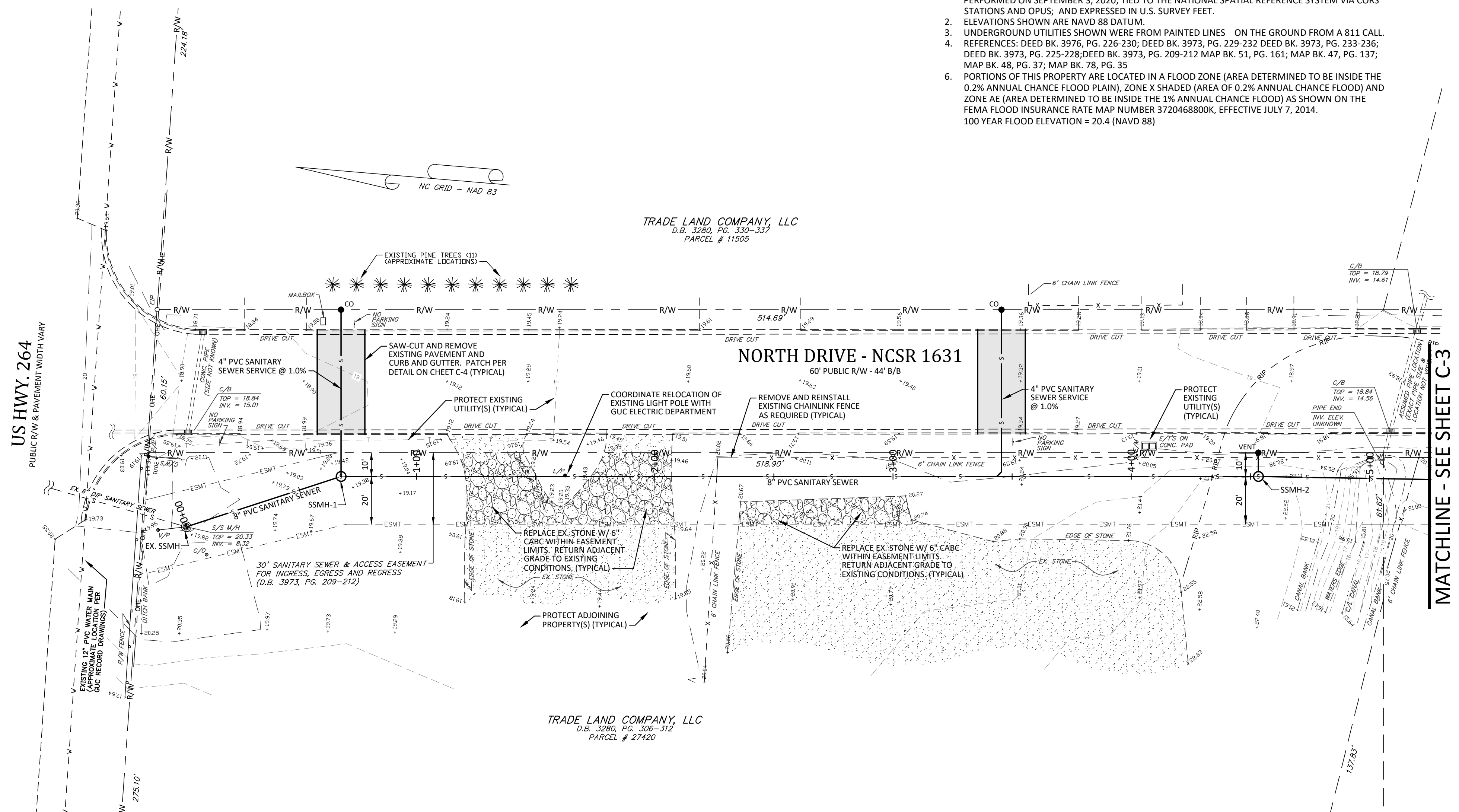

**Survey Notes:**

- BASIS OF THE BEARINGS AND COORDINATES IS THE NORTH CAROLINA STATE PLANE COORDINATE SYSTEM, NORTH AMERICAN DATUM (NAD 83/2011) BASED ON DIFFERENTIAL GPS OBSERVATIONS PERFORMED ON SEPTEMBER 3, 2020; TIED TO THE NATIONAL SPATIAL REFERENCE SYSTEM VIA CORS STATIONS AND OPUS; AND EXPRESSED IN U.S. SURVEY FEET.
- ELEVATIONS SHOWN ARE NAVD 88 DATUM.
- UNDERGROUND UTILITIES SHOWN WERE FROM PAINTED LINES ON THE GROUND FROM A 811 CALL.
- REFERENCES: DEED BK. 3976, PG. 226-230; DEED BK. 3973, PG. 229-232 DEED BK. 3973, PG. 233-236; DEED BK. 3973, PG. 225-228; DEED BK. 3973, PG. 209-212 MAP BK. 51, PG. 161; MAP BK. 47, PG. 137; MAP BK. 48, PG. 37; MAP BK. 78, PG. 35
- PORTIONS OF THIS PROPERTY ARE LOCATED IN A FLOOD ZONE (AREA DETERMINED TO BE INSIDE THE 0.2% ANNUAL CHANCE FLOOD PLAIN), ZONE X SHADED (AREA OF 0.2% ANNUAL CHANCE FLOOD) AND ZONE AE (AREA DETERMINED TO BE INSIDE THE 1% ANNUAL CHANCE FLOOD) AS SHOWN ON THE FEMA FLOOD INSURANCE RATE MAP NUMBER 3720468800K, EFFECTIVE JULY 7, 2014.
- 100 YEAR FLOOD ELEVATION = 20.4 (NAVD 88)

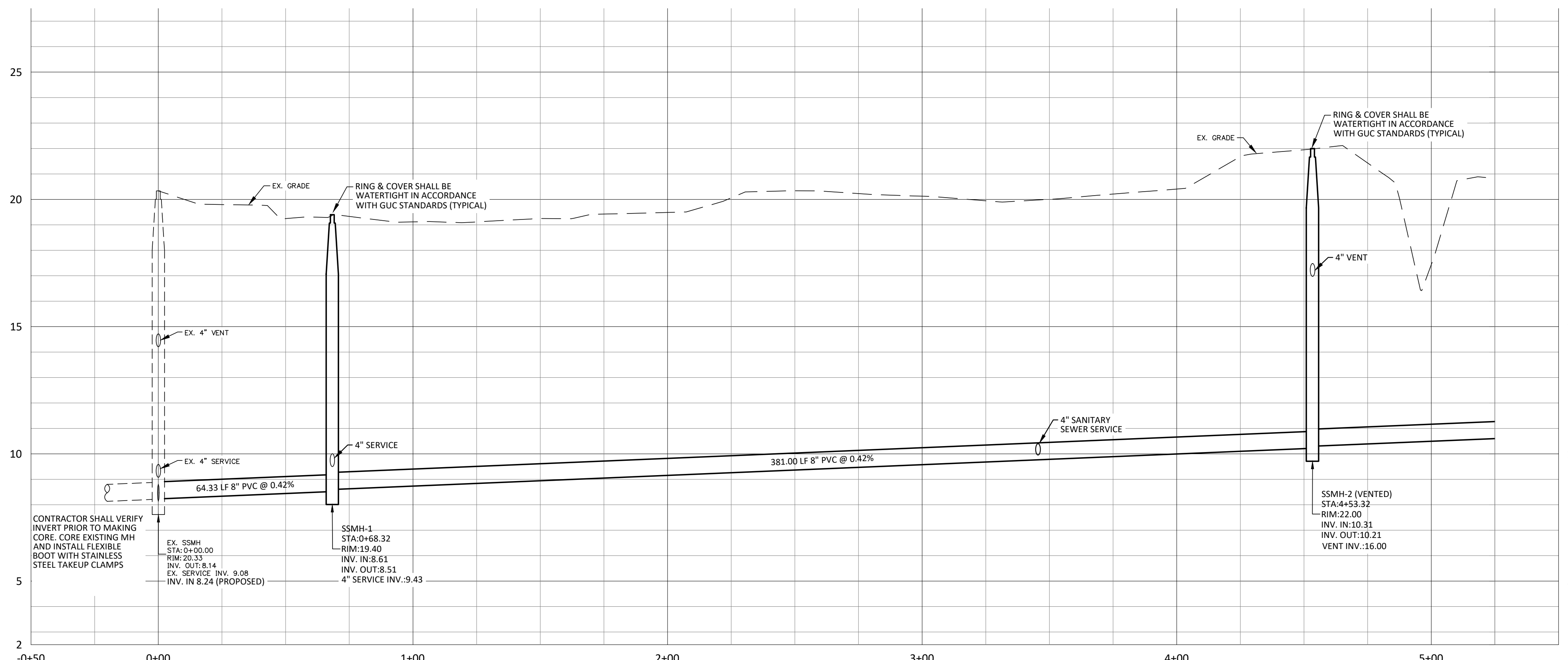

**PLAN AND PROFILES**

**NORTHSIDE COMMERCIAL CENTER SANITARY SEWER EXTENSION**

Greenville Township, Pitt County, North Carolina

**Greenville Utilities**

**ARK CONSULTING GROUP PLLC**  
ENGINEERS & PLANNERS  
2755-B Charles Blvd  
Greenville, NC 27858  
(252) 558-0888  
www.arkconsultinggroup.com

**Professional Engineer Seal:** ARK CONSULTING GROUP PLLC, STATE OF NORTH CAROLINA, ENGINEER, No. 31970, EXPIRES 2/15/2021

**Project Manager:** BCF  
**Drawn By:** EW  
**Checked By:** STA  
**Project Number:** 20049  
**Drawing Number:** D-1244

**C-2**

Date: 12-07-2020



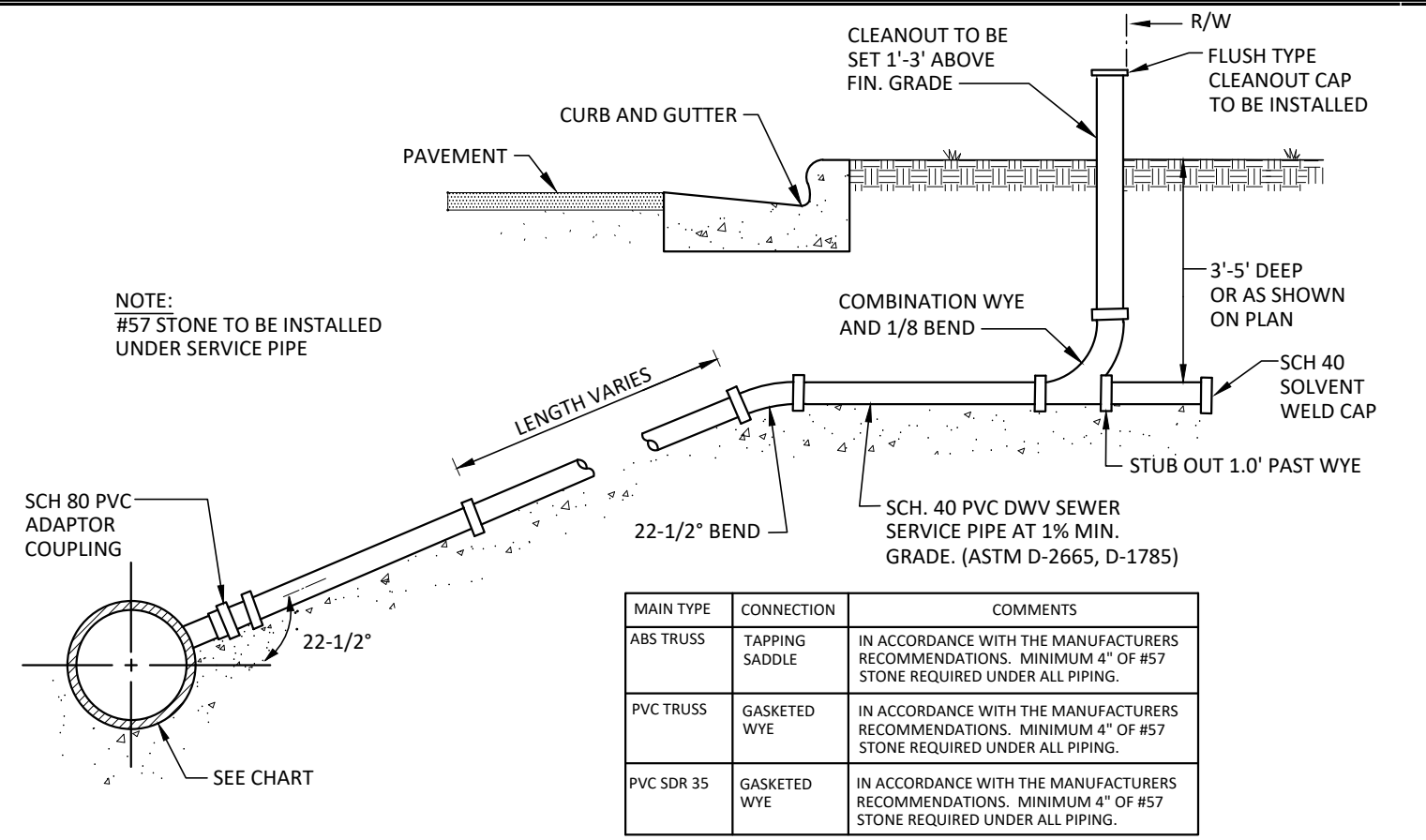

**PVC SANITARY SEWER SERVICE DETAIL FOR AREA WITH CURB AND GUTTER FOR MAINS WITH A MAXIMUM DEPTH OF 12'**  
(S-1) NOT TO SCALE

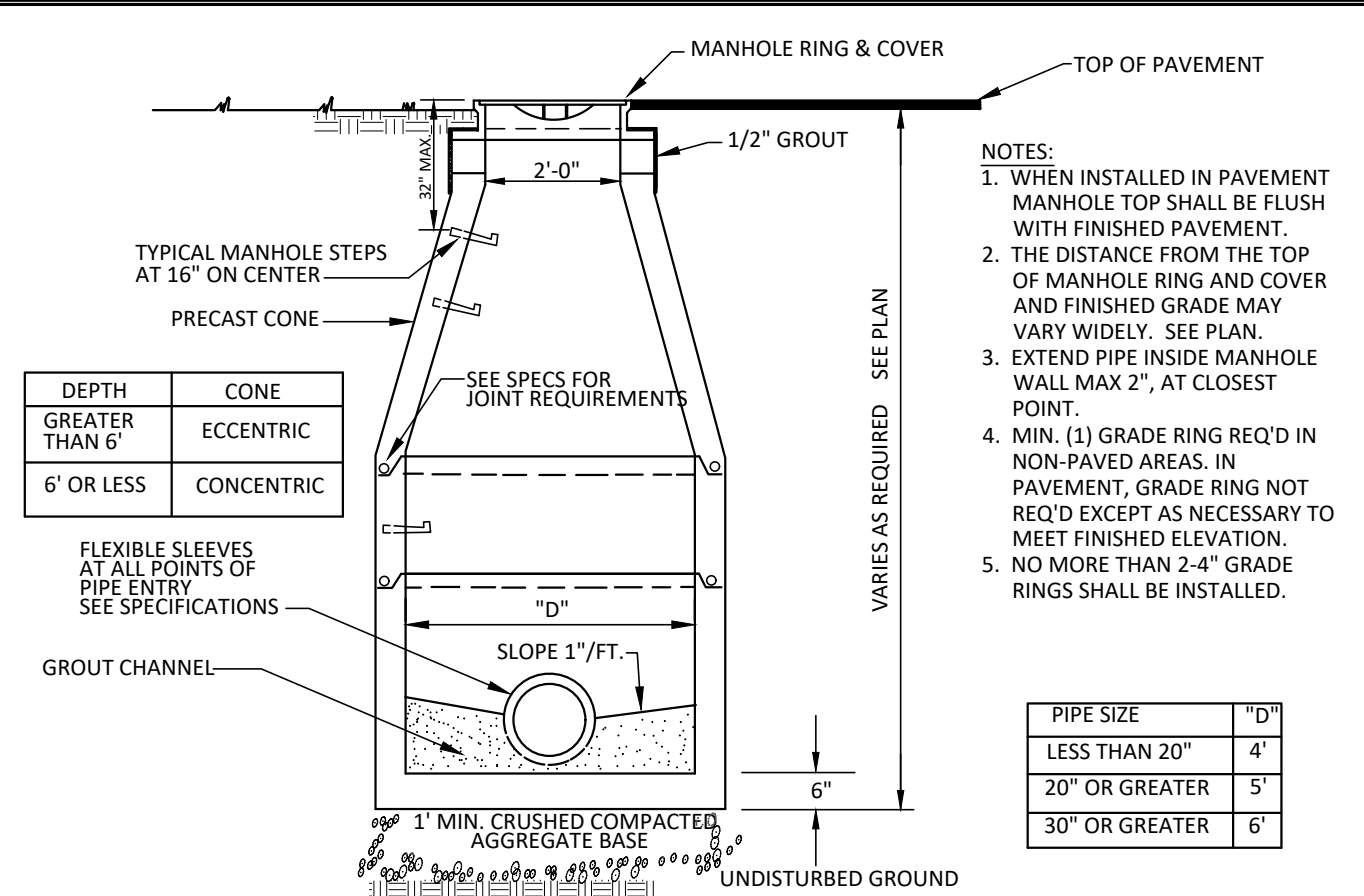

**TYPICAL PRECAST VENTED MANHOLE**  
(S-4) NOT TO SCALE

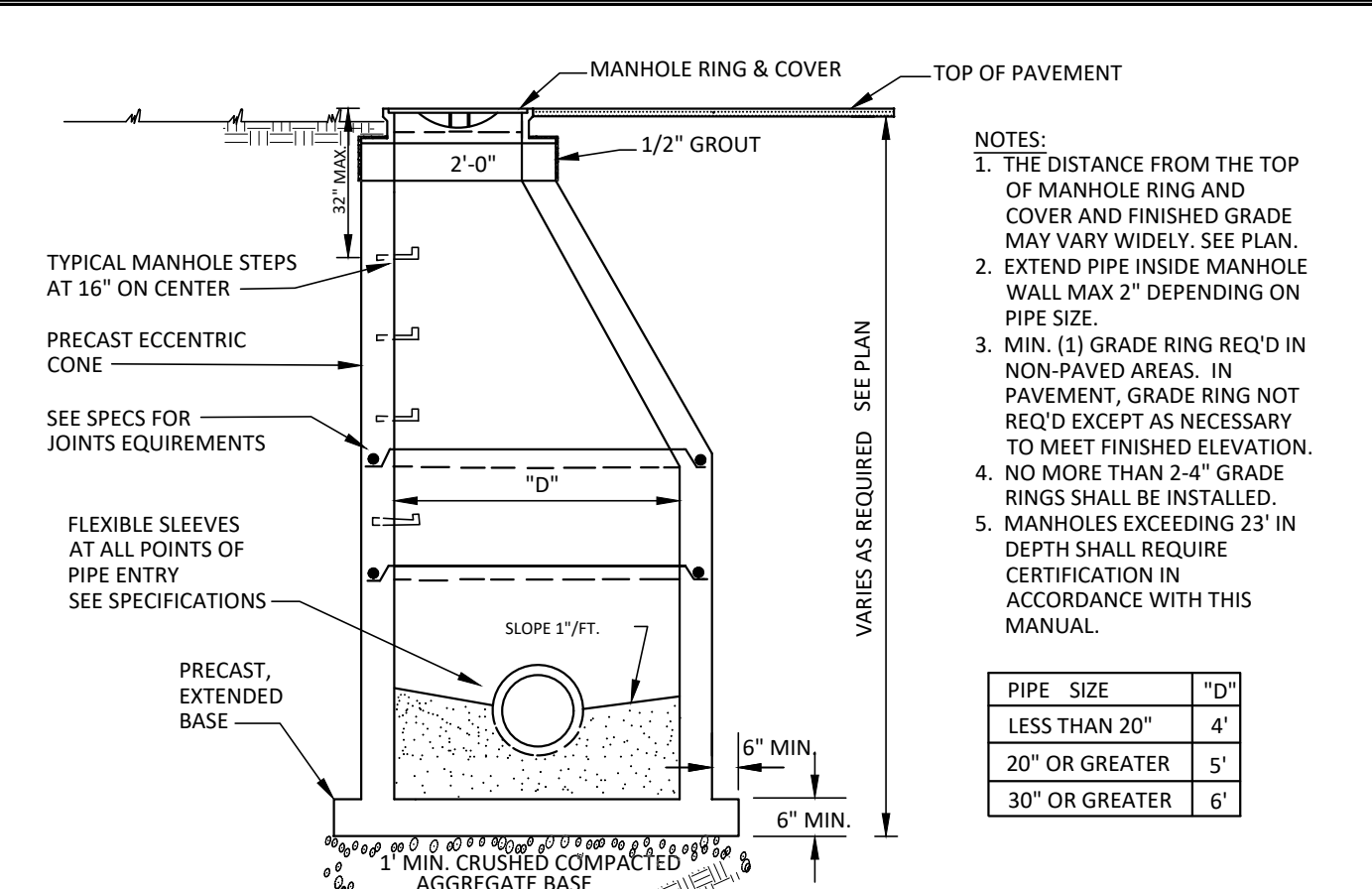

**TYPICAL PRECAST MANHOLE FOR MANHOLES OVER 12' IN DEPTH**  
(S-5) NOT TO SCALE

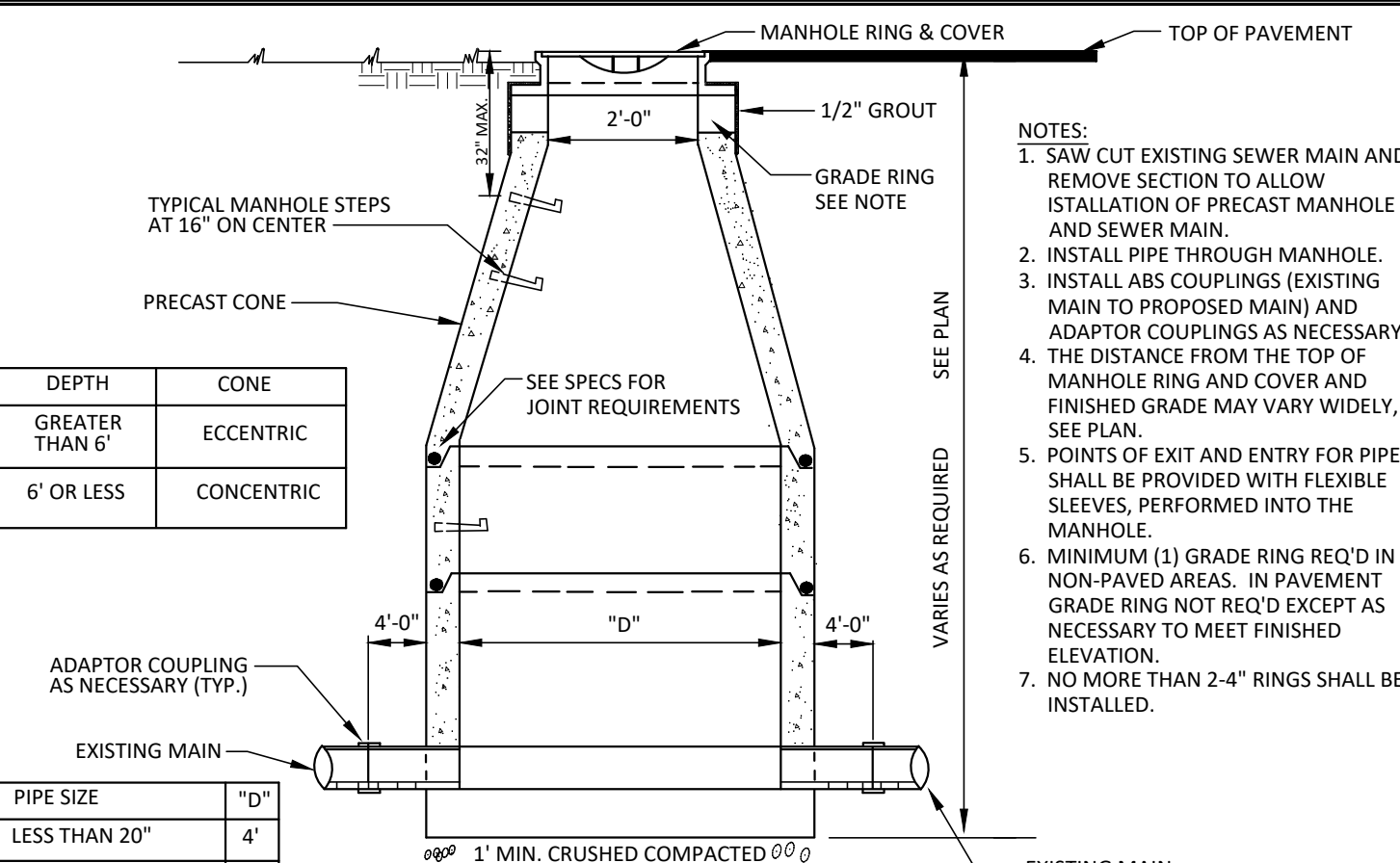

**PRECAST MANHOLE INSTALLATION OVER EXISTING SEWER MAIN**  
(S-7) NOT TO SCALE

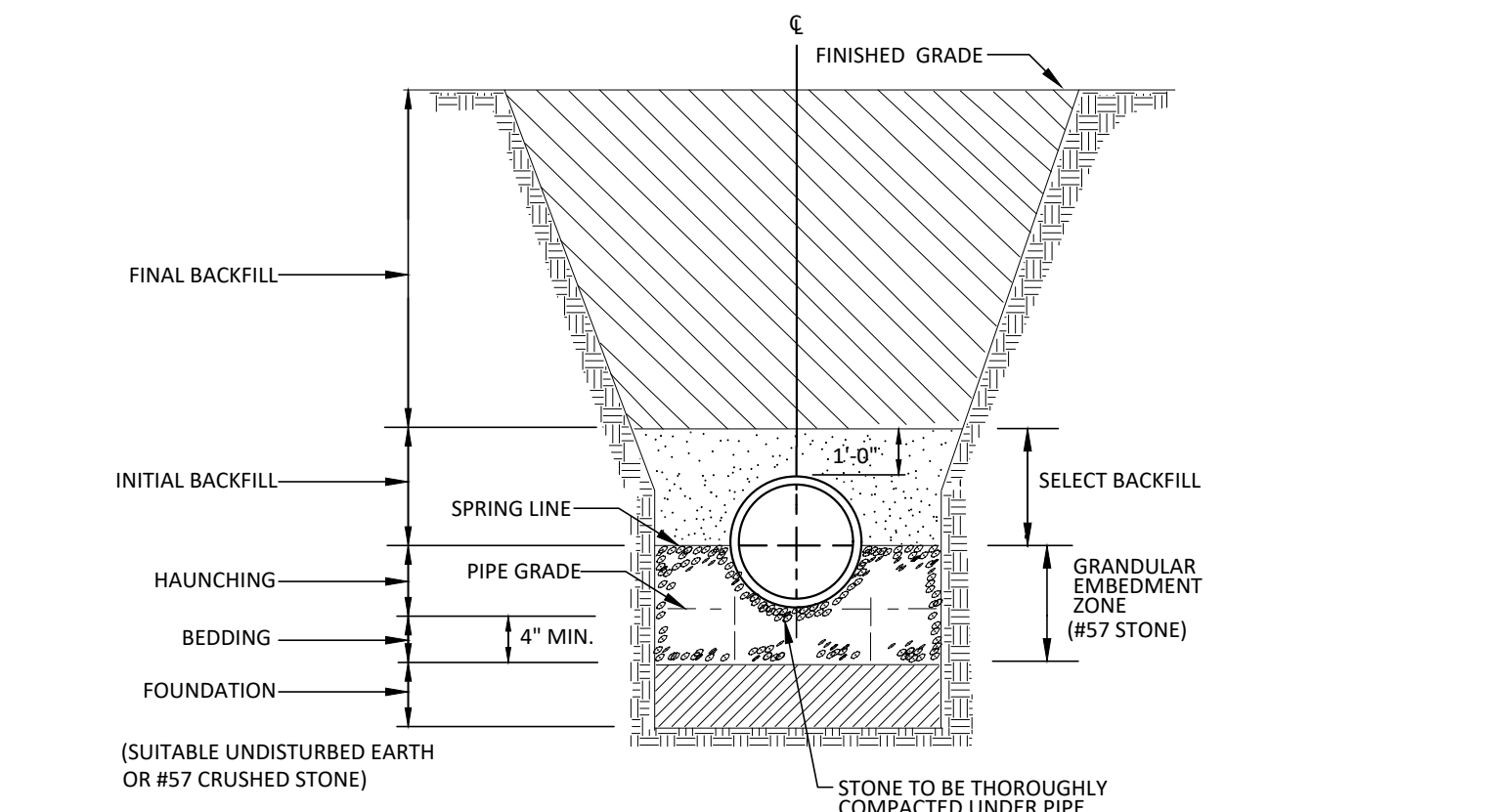

**TRENCH SECTION DETAIL FOR THE INSTALLATION OF VITRIFIED CLAY, ABS, AND PVC TRUSS SANITARY SEWER PIPE**  
(S-8) NOT TO SCALE

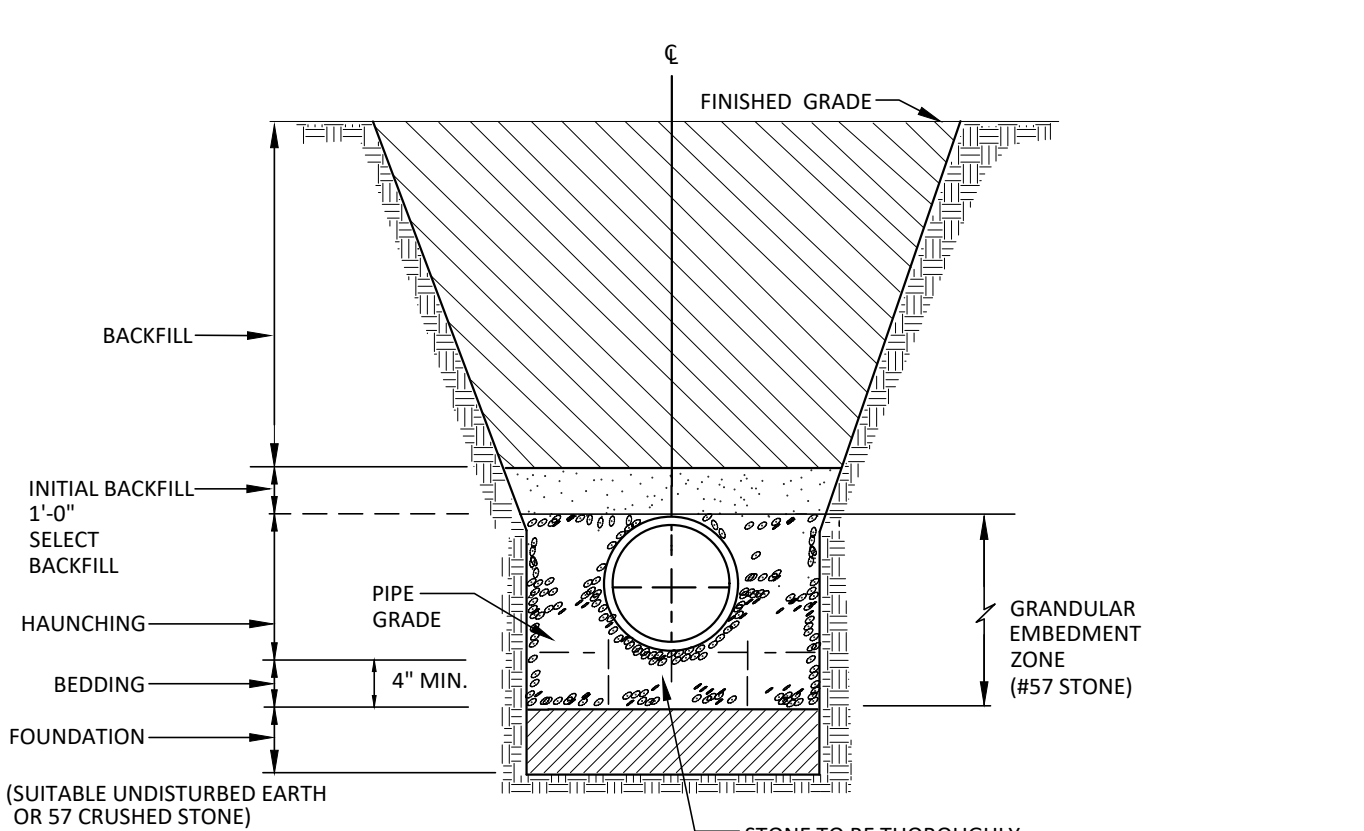

**TRENCH SECTION DETAIL FOR THE INSTALLATION OF PVC SANITARY SEWER PIPE (NOT INCLUDING TRUSS)**  
(S-9) NOT TO SCALE

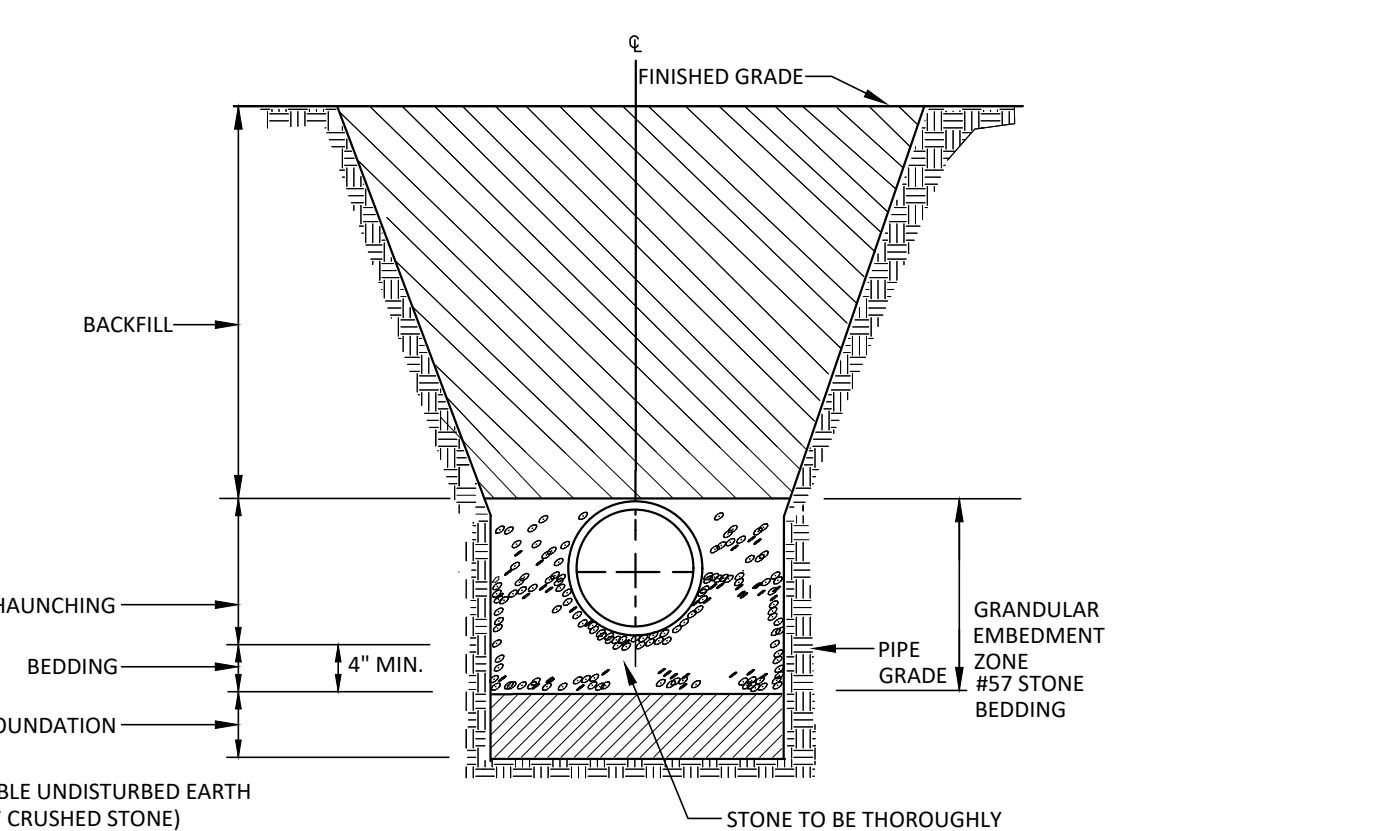

**TRENCH SECTION DETAIL FOR THE INSTALLATION OF PVC SANITARY SEWER PIPE - SCH40 DWV**  
(S-10) NOT TO SCALE

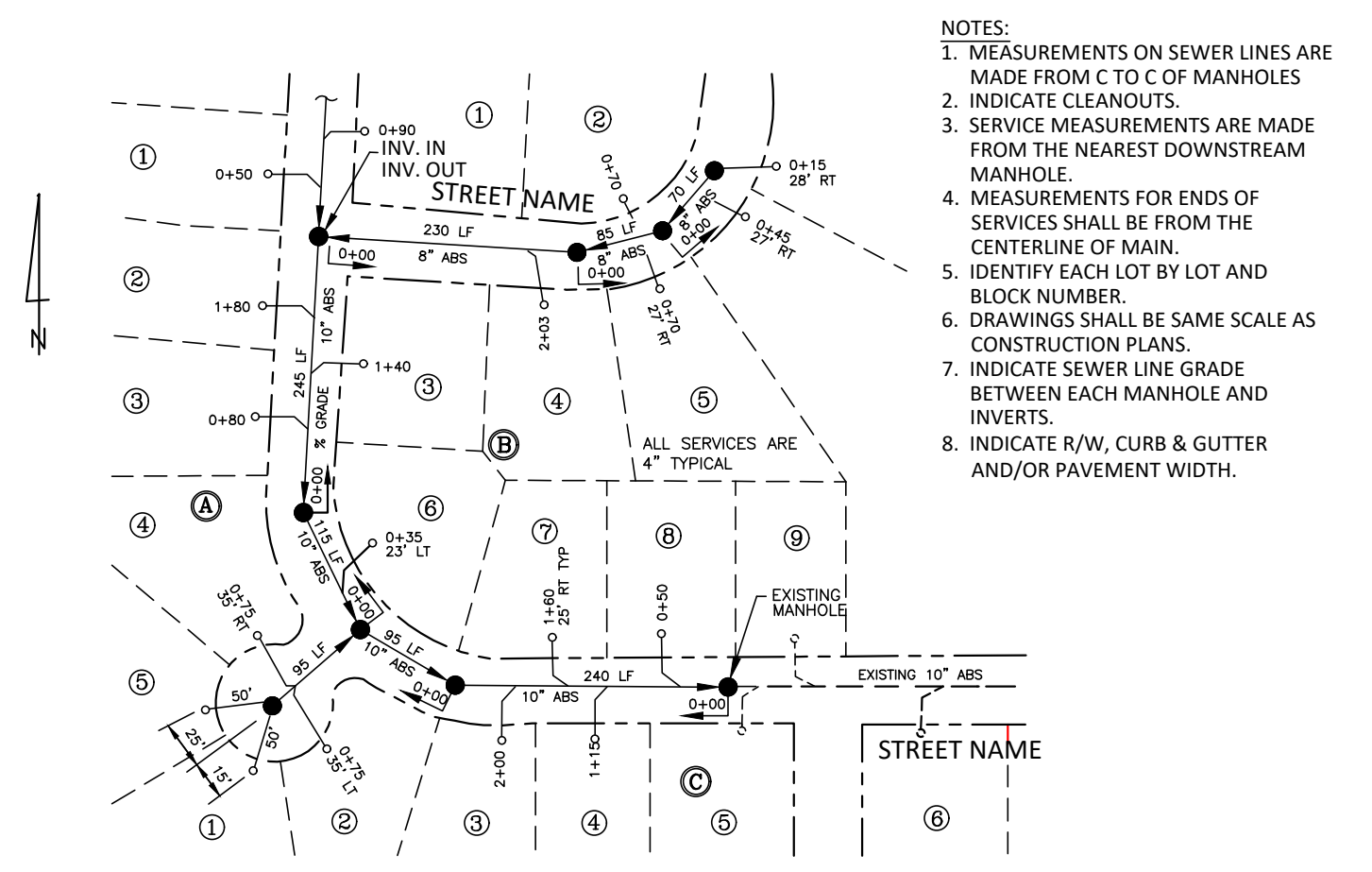

**TYPICAL SEWER SYSTEM "AS BUILT"**  
(S-16) NOT TO SCALE

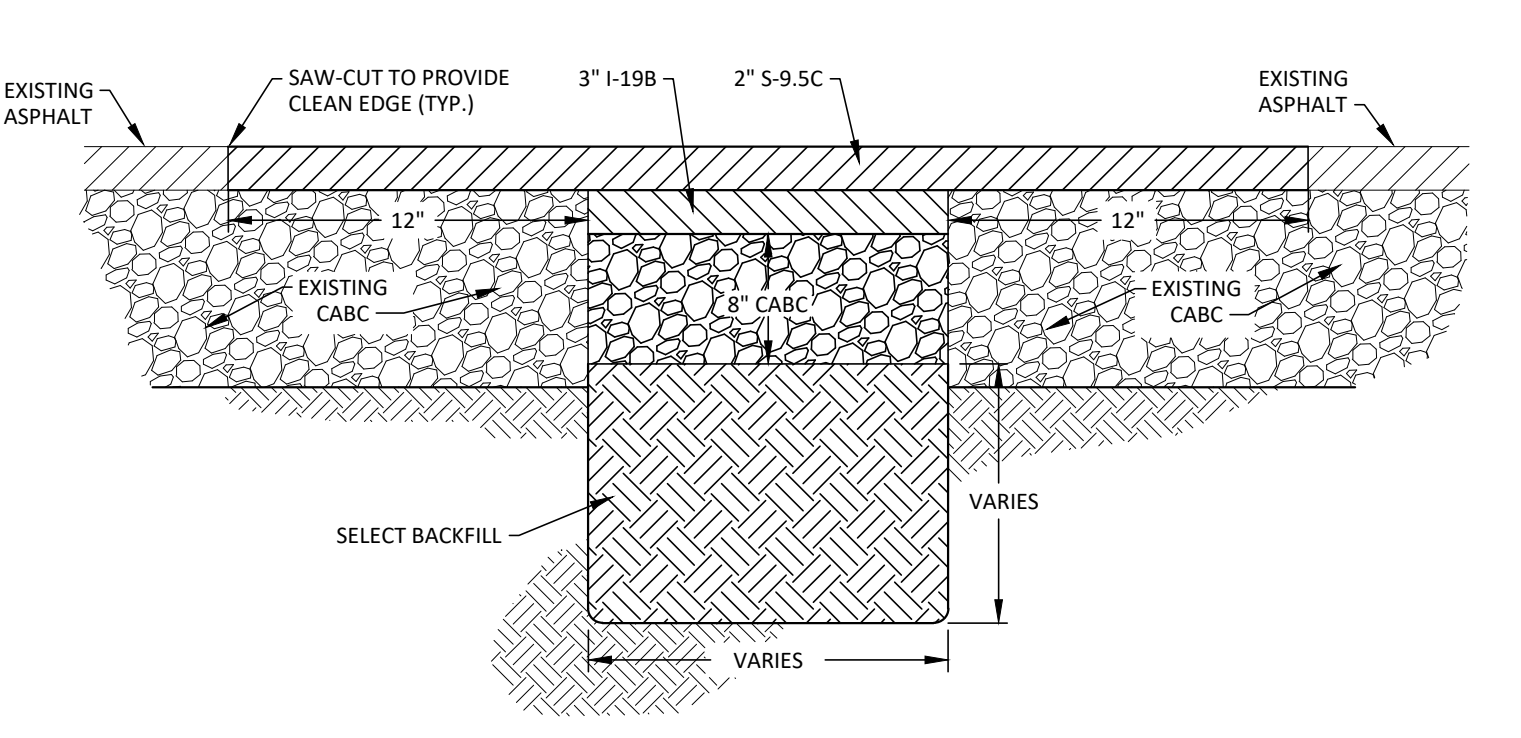

**ASPHALT PATCH DETAIL**  
NOT TO SCALE

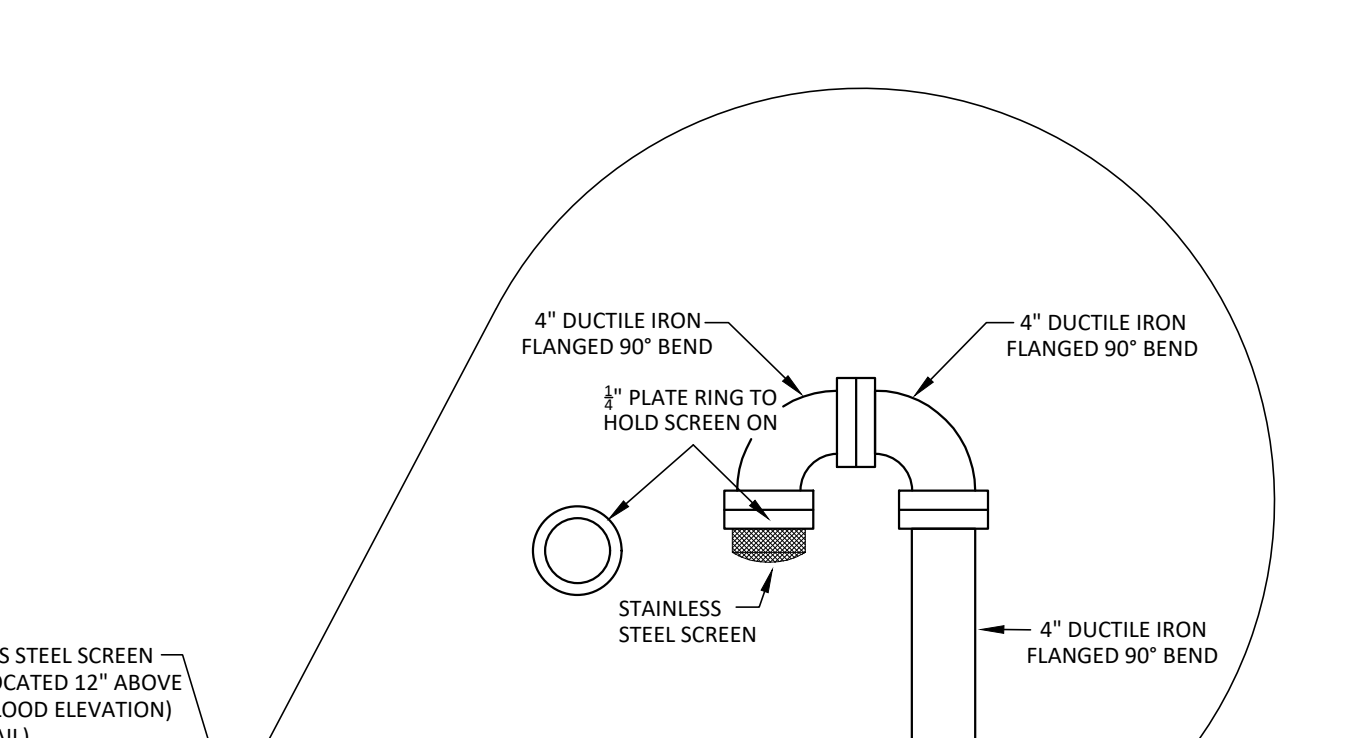

**VENT PIPE DETAIL**

- General Notes:**
- CONTRACTOR SHALL CONTACT NORTH CAROLINA ONE-CALL CENTER, INC. (NC ONE-CALL) AT 811 TO HAVE ALL UNDERGROUND UTILITIES LOCATED AT LEAST 72 HOURS PRIOR TO EXCAVATING OR TRENCHING.
  - ALL REQUIRED IMPROVEMENTS SHALL CONFORM TO THE GREENVILLE UTILITIES MANUAL FOR THE DESIGN AND CONSTRUCTION OF WATER AND WASTEWATER SYSTEM EXTENSIONS.
  - CONTRACTOR SHALL NOTIFY NC DEPARTMENT OF TRANSPORTATION, 72 HOURS PRIOR TO CLOSURE OF ROADWAY AND CUTTING PAVEMENT IN ROADWAY RIGHT-OF-WAY.
  - CONTRACTOR SHALL SUBMIT SHOP DRAWINGS TO ENGINEER IN ACCORDANCE WITH THE TECHNICAL SPECIFICATIONS FOR MATERIALS TO BE USED IN THE CONSTRUCTION OF UTILITY AND ROADWAY IMPROVEMENTS. SHOP DRAWINGS SHALL BE REVIEWED AND APPROVED BY THE ENGINEER PRIOR TO ORDERING MATERIALS.
  - LOCATION OF ALL EXISTING AND PROPOSED UTILITIES ARE APPROXIMATE AND MUST BE CONFIRMED INDEPENDENTLY WITH UTILITY OWNERS PRIOR TO COMMENCEMENT OF ANY CONSTRUCTION OR EXCAVATION. UTILITY SERVICES CONNECTION POINTS SHALL BE CONFIRMED INDEPENDENTLY BY THE CONTRACTOR IN THE FIELD PRIOR TO THE COMMENCEMENT OF CONSTRUCTION. DISCREPANCIES SHALL BE REPORTED IMMEDIATELY IN WRITING TO ENGINEER. CONSTRUCTION SHALL COMMENCE BEGINNING AT THE LOWEST INVERT (POINT OF CONNECTION) AND PROGRESS UPSTREAM. PROPOSED INTERFACE POINTS (CROSSINGS) WITH EXISTING UNDERGROUND UTILITIES SHALL BE FIELD VERIFIED BY TEST PIT PRIOR TO COMMENCEMENT OF CONSTRUCTION.
  - ALL UTILITIES AND SERVICES INCLUDING BUT NOT LIMITED TO GAS, WATER, ELECTRIC, SANITARY AND STORM SEWER, TELEPHONE, CABLE, FIBER OPTIC CABLE WITHIN THE LIMITS OF DISTURBANCE SHALL BE VERTICALLY AND HORIZONTALLY LOCATED. THE CONTRACTOR SHALL COMPLY WITH THE REQUIREMENTS OF THE APPLICABLE UTILITY AND SERVICE. THE CONTRACTOR SHALL BE RESPONSIBLE FOR REPAIRS OF DAMAGE TO ANY EXISTING UTILITIES DURING CONSTRUCTION AT NO COST TO THE OWNER.
  - IT IS THE RESPONSIBILITY OF THE CONTRACTOR TO REVIEW ALL OF THE DRAWINGS AND SPECIFICATIONS ASSOCIATED WITH THE PROJECT WORK SCOPE PRIOR TO THE INITIATION OF CONSTRUCTION. SHOULD THE CONTRACTOR FIND A CONFLICT WITH THE DOCUMENTS RELATIVE TO THE SPECIFICATIONS OR THE RELATIVE COORDINATES, IT IS THE CONTRACTOR'S RESPONSIBILITY TO NOTIFY THE PROJECT ENGINEER IN WRITING PRIOR TO COMMENCING CONSTRUCTION. FAILURE BY THE CONTRACTOR TO NOTIFY THE PROJECT ENGINEER SHALL CONSTITUTE ACCEPTANCE OF FULL RESPONSIBILITY BY THE CONTRACTOR TO COMPLETE THE SCOPE OF WORK AS DEFINED BY THE DRAWINGS AND IN FULL COMPLIANCE WITH LOCAL AND STATE REGULATIONS AND CODES.
  - THE CONTRACTOR SHALL FAMILIARIZE THEMSELVES WITH GREENVILLE UTILITIES COMMISSION REQUIREMENTS AND IS RESPONSIBLE FOR ALL COORDINATION REGARDING UTILITY INSTALLATION AS IDENTIFIED OR REQUIRED FOR THE PROJECT.
  - SEED OR OTHERWISE PROVIDE GROUND COVER DEVICES OR STRUCTURES SUFFICIENT TO RESTRAIN EROSION FOR ALL EXPOSED SLOPES WITHIN 7 DAYS OF COMPLETION OF ANY PHASE OF GRADING ON PERIMETER AREAS AND SLOPES STEEPER THAN 3:1. ALL OTHER AREAS SHALL BE STABILIZED WITHIN 14 DAYS.
  - CONTRACTOR SHALL INSPECT AND MAINTAIN AS NEEDED ALL EROSION CONTROL DEVICES ON A WEEKLY BASIS AND AFTER EACH MAJOR STORM EVENT. FAILURE TO KEEP ALL EROSION CONTROL DEVICES IN PROPER WORKING ORDER MAY RESULT IN A STOP WORK ORDER OR CIVIL PENALTIES UP TO \$5,000.00 PER DAY OF VIOLATION.
  - THE ENGINEER RESERVES THE RIGHT TO REQUIRE ADDITIONAL EROSION CONTROL MEASURES SHOULD THE PLAN OR ITS IMPLEMENTATION PROVE TO BE INADEQUATE.
  - EROSION CONTROL MEASURES SHALL BE MAINTAINED AND INSPECTED AS PER THE DETAIL SHEETS SHOWN.
  - PLEASE BE ADVISED OF THE RULES TO PROTECT AND MAINTAIN EXISTING BUFFERS ALONG WATERCOURSES IN THE NEUSE AND TAR/PAMUNCO RIVER BASINS. THESE RULES ARE ENFORCED BY THE DIVISION OF WATER RESOURCES (DWR). DIRECT ANY QUESTIONS ABOUT THE APPLICABILITY OF THESE RULES TO YOUR PROJECT TO THE REGIONAL WATER QUALITY SUPERVISOR, WASHINGTON REGIONAL OFFICE AT (252) 946-6481.
  - LAND DISTURBING ACTIVITY BEYOND THAT REQUIRED TO INSTALL APPROPRIATE EROSION CONTROL MAY NOT PROCEED UNTIL EROSION CONTROL MEASURES ARE INSPECTED AND APPROVED BY THE ENGINEER.
  - PROVIDE 20' X 50' X 6" STONE CONSTRUCTION ENTRANCES AS SHOWN ON PLAN.
  - NO SEWER SERVICE SHALL BE PROVIDED FOR PROPERTIES WITHIN THIS PROJECT AREA UNTIL ALL MAINS AND SERVICES HAVE BEEN INSTALLED AND ACCEPTED FOR MAINTENANCE BY G.U.C.

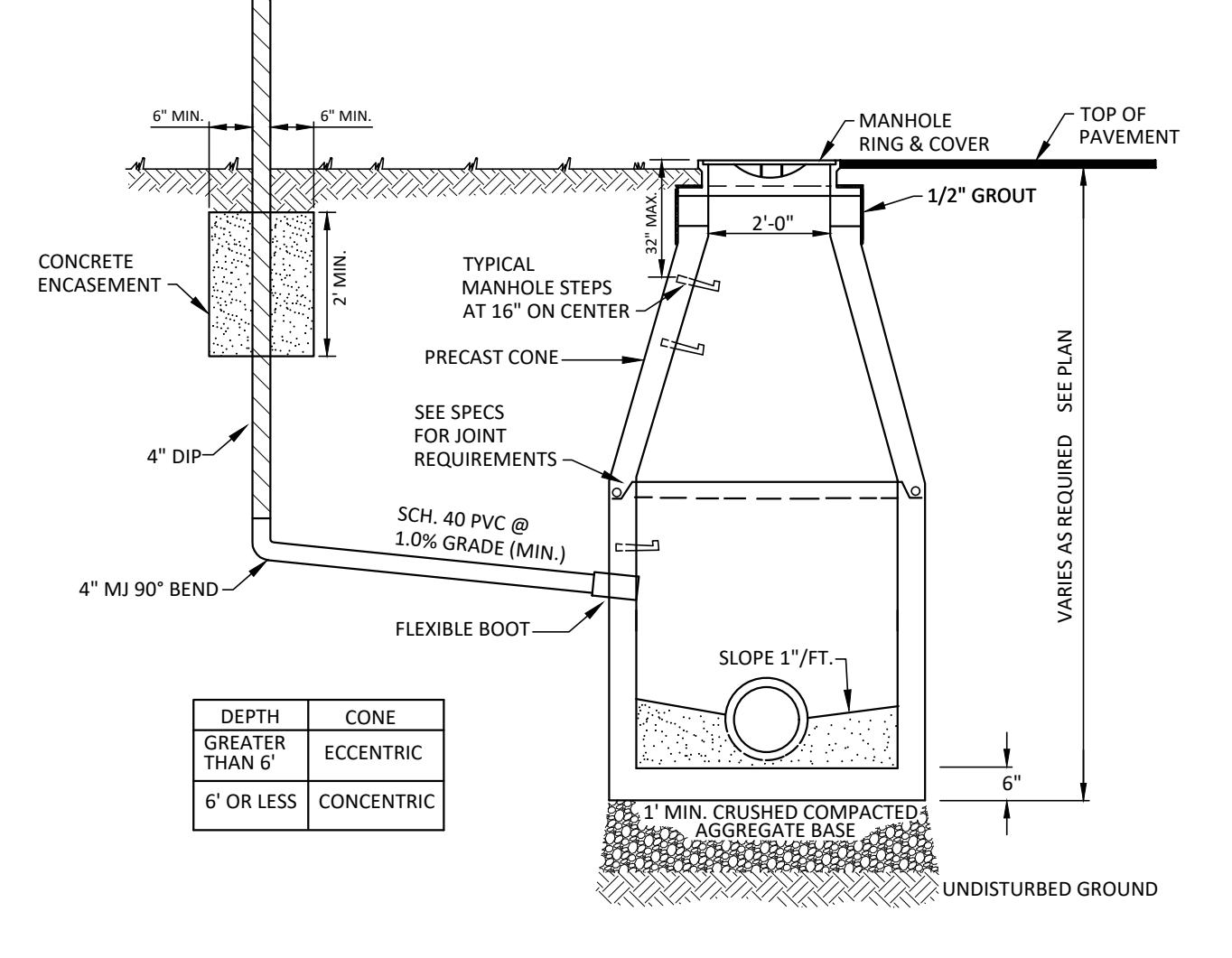

**TYPICAL PRECAST VENTED MANHOLE**  
NOT TO SCALE

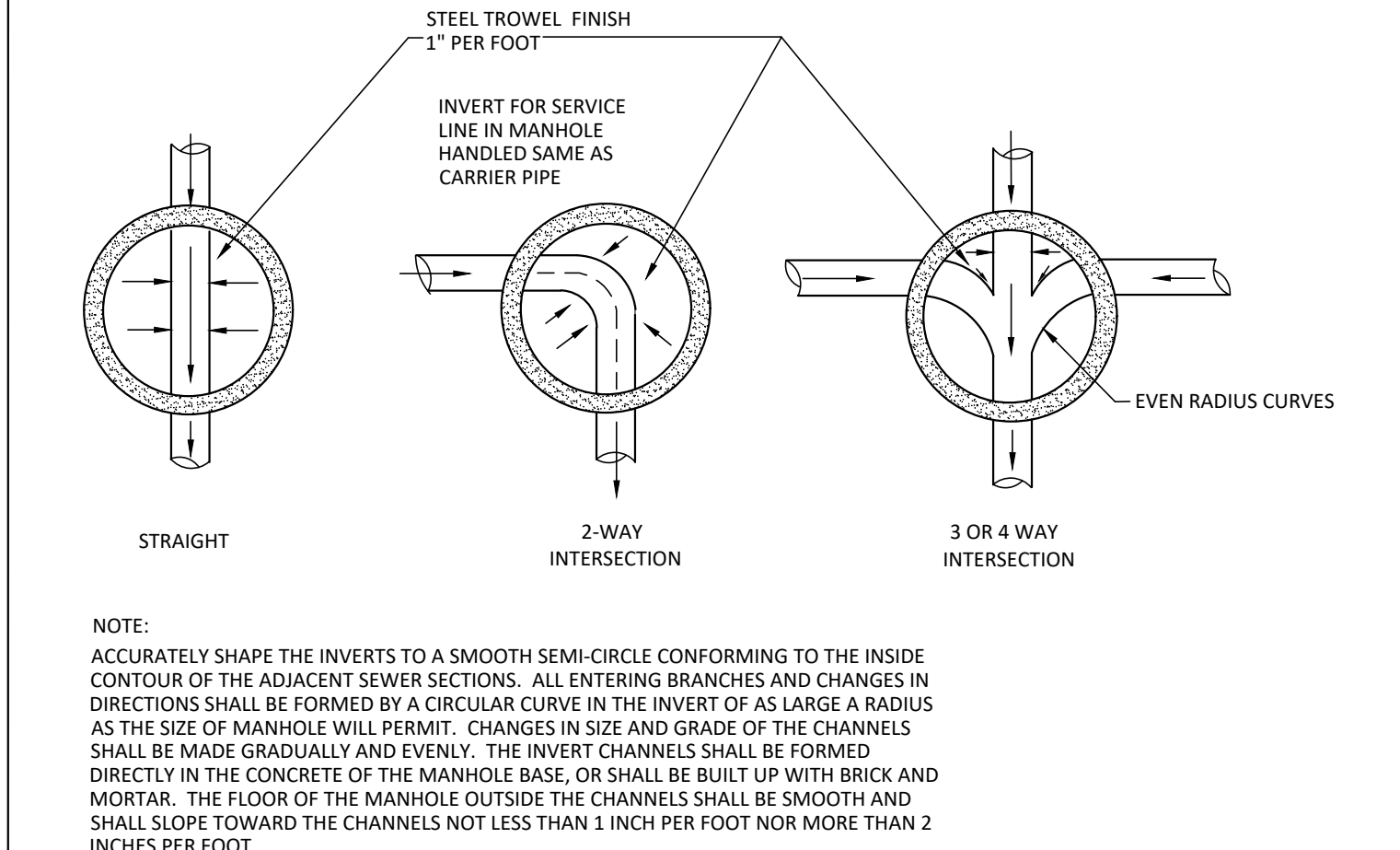

**MANHOLE INVERTS**  
(S-17) NOT TO SCALE

- Permanent Seeding Schedule:**
- Grades on the area to be seeded shall be maintained in a true and even condition. Maintenance shall include any necessary repairs to previously graded areas. All graded areas shall be thoroughly tilled to a depth of at least four (4) inches by plowing, disking, harrowing, or other approved methods until the condition of the soil is acceptable. On sites where soil conditions are such that high clay content and/or excessive compaction cause difficulty in getting clods and lumps effectively pulverized, the Contractor shall use the rotary tillage machinery until the mixing of the soil is acceptable and no clods or clumps remain larger than 1 1/2 inches in diameter. A firm and compact seed bed is required and after being graded, the seed bed shall be lightly compacted with a land roller, such as a cultipacker, before and after seeding. Limestone shall be dolomitic agriculture ground limestone containing not less than 10 percent magnesium oxide. Lime shall be uniformly applied at the rate of 2 tons per acre. Fertilizer shall be uniformly applied at a rate of 500 pounds per acre of 10-20-20 analysis. The fertilizer shall be incorporated into the upper three or four inches of prepared seed bed just prior to the last tillage operation, but in no case shall it be applied more than three days prior to seeding. Fertilizer shall be used immediately after delivery or stored in a manner that will not permit it to harden or destroy its effectiveness.
- | Seed Bed Preparation     | Lime              | Fertilizer (10-20-20) | Seeding Mixture:                |
|--------------------------|-------------------|-----------------------|---------------------------------|
| (January 1 - March 31)   | - 2 tons per acre | - 500 pounds per acre | Common Bermuda grass (unhulled) |
|                          |                   |                       | Rye (grain)                     |
|                          |                   |                       | - 20 pounds per acre            |
|                          |                   |                       | - 25 pounds per acre            |
| (April 1 - July 31)      |                   |                       | Common bermudagrass (hulled)    |
|                          |                   |                       | Weeping Lovegrass               |
|                          |                   |                       | Centpede                        |
|                          |                   |                       | - 15 pounds per acre            |
|                          |                   |                       | - 5 pounds per acre             |
|                          |                   |                       | - 8 pounds per acre             |
| (August 1 - December 31) |                   |                       | Common Bermuda grass (unhulled) |
|                          |                   |                       | Tall Fescue                     |
|                          |                   |                       | Rye (grain)                     |
|                          |                   |                       | - 20 pounds per acre            |
|                          |                   |                       | - 60 pounds per acre            |
|                          |                   |                       | - 25 pounds per acre            |

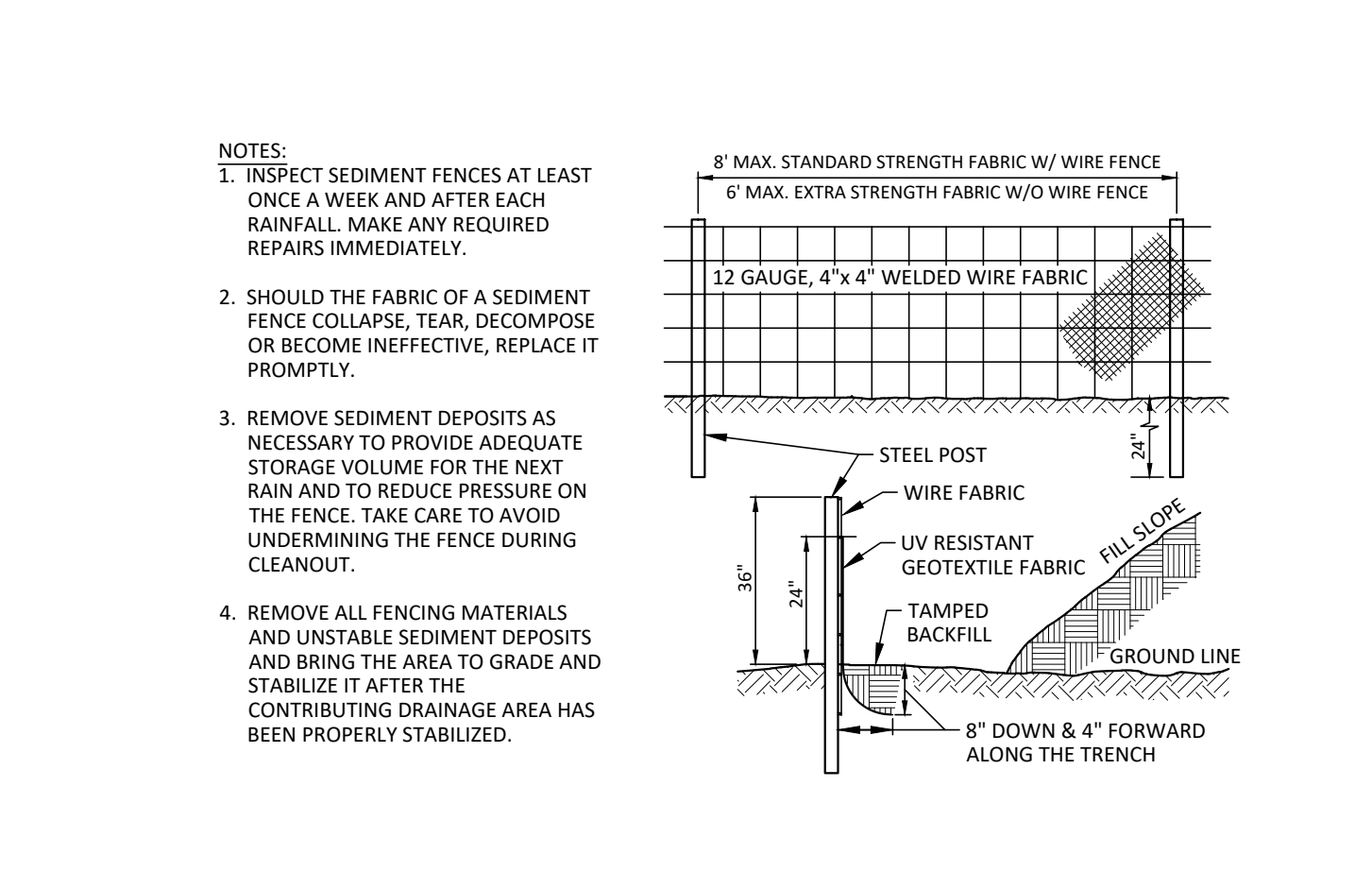

**TEMPORARY SILT FENCE**  
NOT TO SCALE

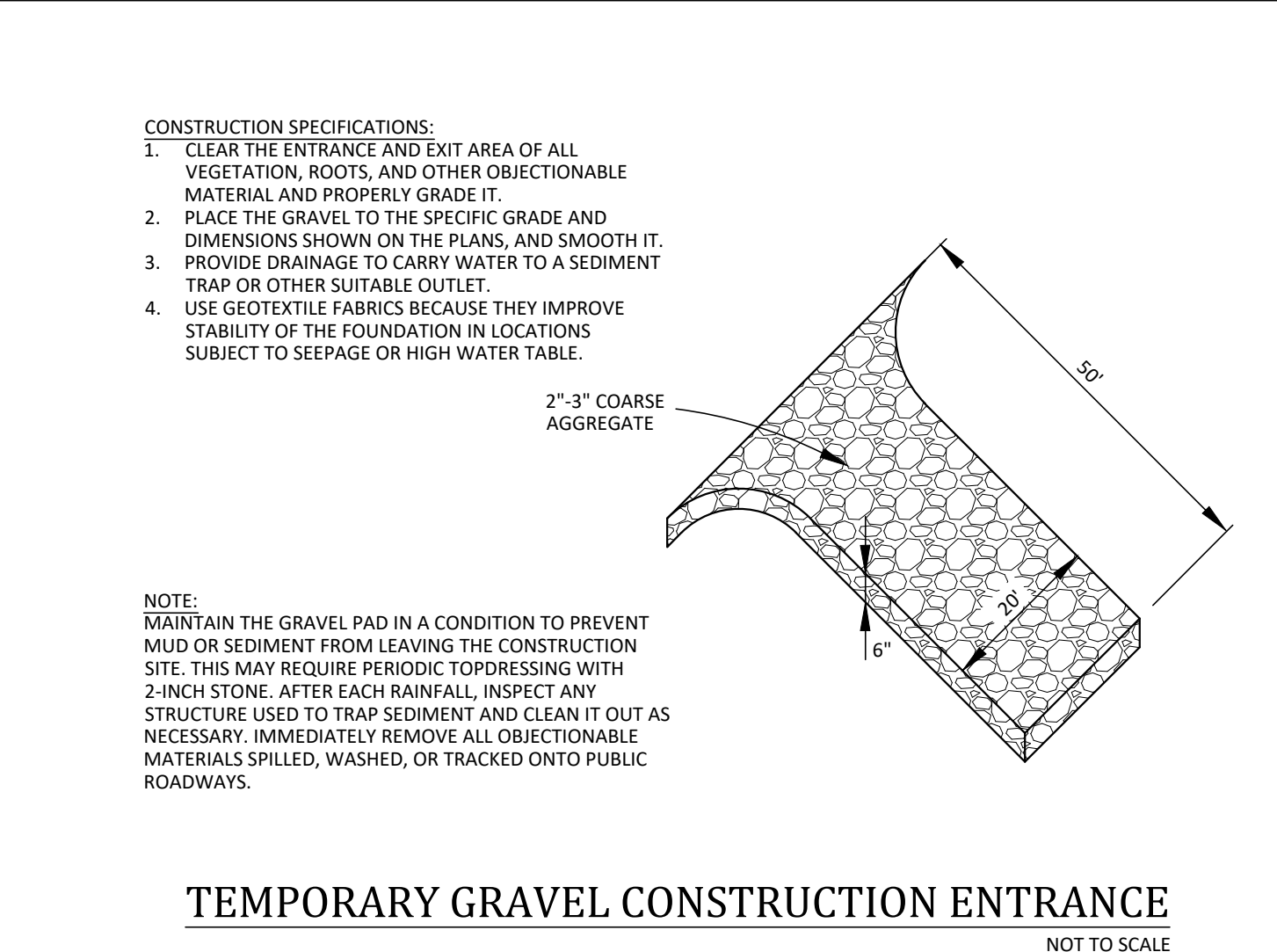

**TEMPORARY GRAVEL CONSTRUCTION ENTRANCE**  
NOT TO SCALE

**Greenville Utilities**

**NORTHSIDE COMMERCIAL CENTER SANITARY SEWER EXTENSION**  
Greenville Township, Pitt County, North Carolina

**DETAILS**

**REVISIONS:**

| NO. | DATE       | COMMENTS                                     |
|-----|------------|--|
| 1   | 10/20/2021 | REVISED TO ADD SERVICES FOR PN 27852 & 42309 |

**PROJECT INFORMATION:**

Project Manager: BCF  
Drawn By: EW  
Checked By: STA  
Project Number: 20049  
Drawing Number: D-1244

**ARK CONSULTING GROUP, INC.**  
2785-B Charles Blvd  
Greenville, NC 27858  
(252) 558-0888  
www.arkconsultinggroup.com

**Professional Engineer Seal:** 31970, 2/15/2021

Date: 12-07-2020

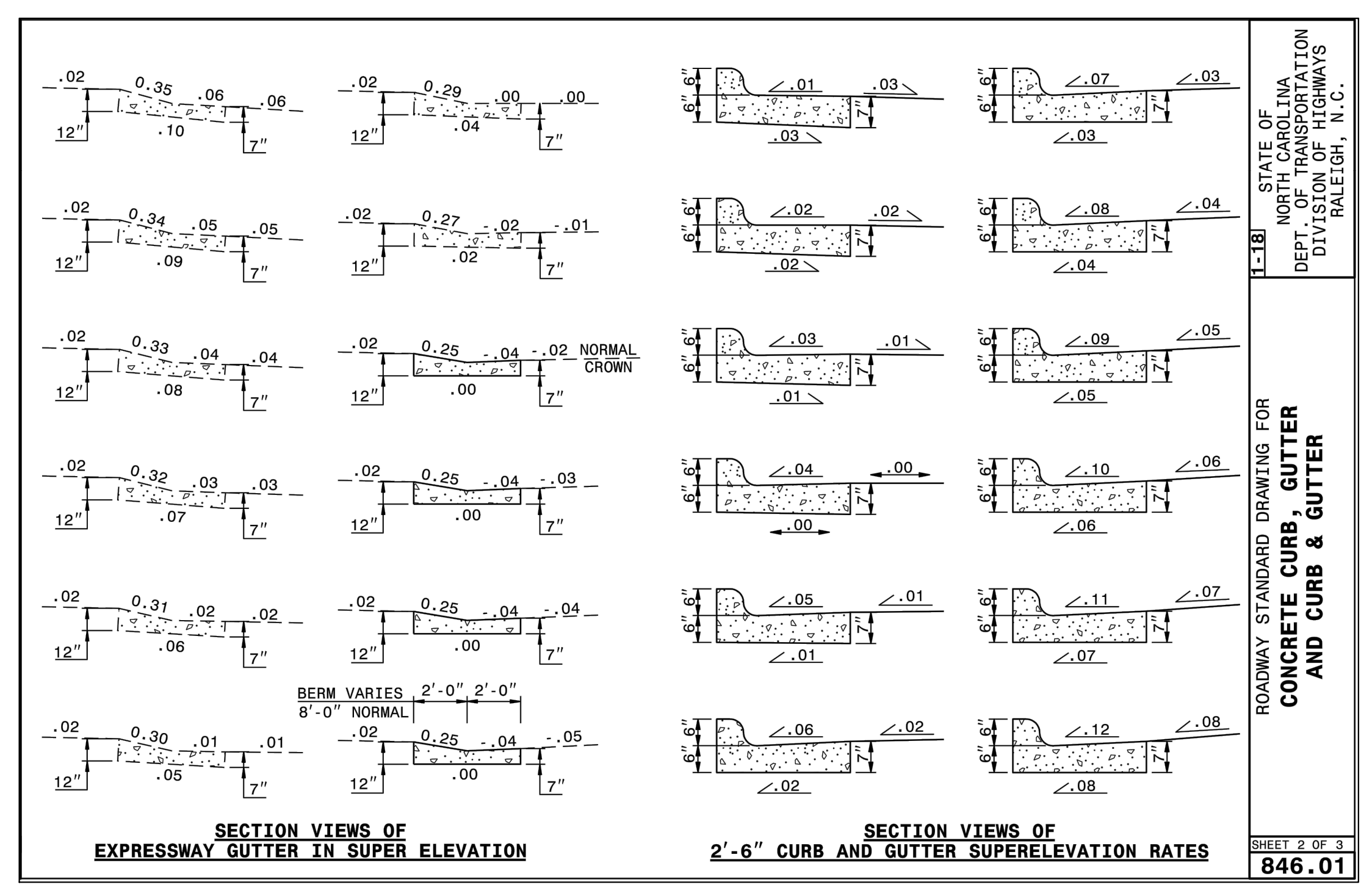
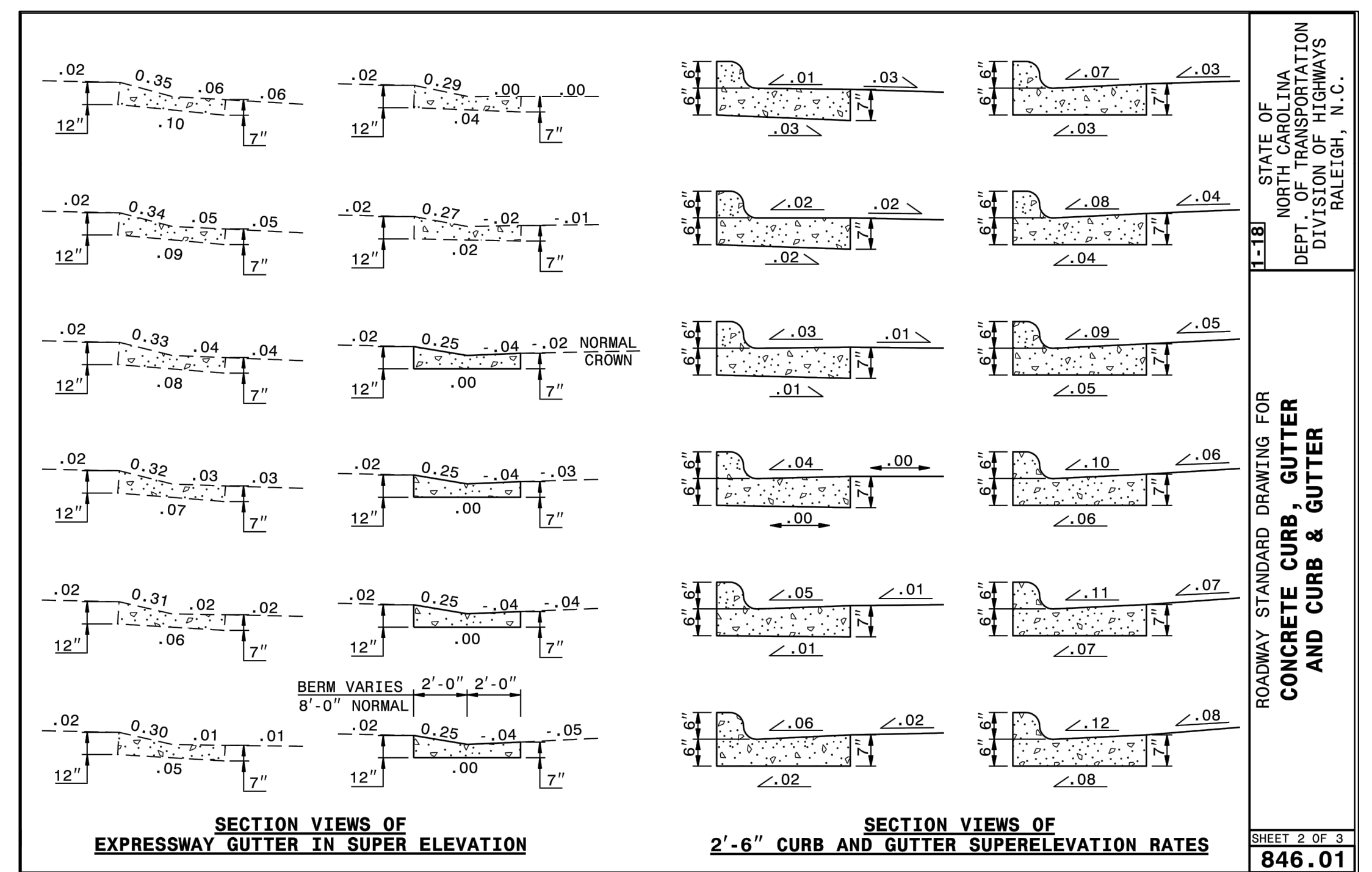
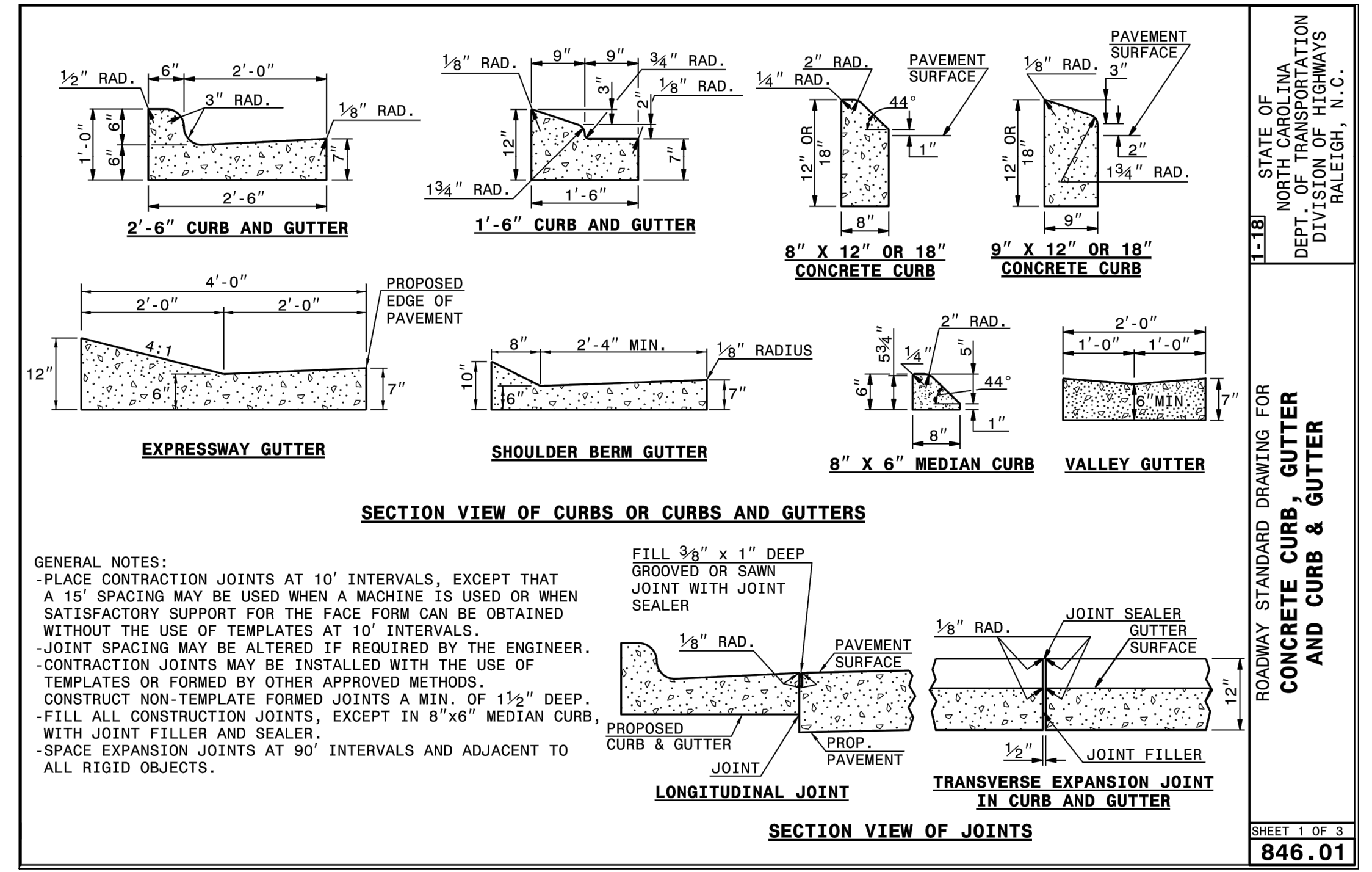

COMMENTS  
 1 12/07/2020 REVISED TO ADD SERVICES FOR PN 27852 & 42309

REVISIONS:

**Greenville Utilities**

**DETAILS**

**NORTHSIDE COMMERCIAL CENTER  
 SANITARY SEWER EXTENSION**

Greenville Township, Pitt County, North Carolina

NC License # 1199

**ARK CONSULTING GROUP, PLLC**  
 ENGINEERS & PLANNERS

2755-B Charles Blvd.  
 Greenville, NC 27858  
 (252) 558-0888  
 www.arkconsultinggroup.com

2/15/2021

Project Manager: BCF  
 Drawn By: EW  
 Checked By: STA  
 Project Number: 20049  
 Drawing Number: D-1244

**C-5**

Date: 12-07-2020