

ADVERTISEMENT FOR BIDS

Sealed proposals will be received in the Office of the Purchasing Technician, Greenville Utilities Commission, 401 S. Greene Street, Greenville, North Carolina 27834 until 2:00 PM (EDST) on November 20, 2013 and immediately thereafter publicly opened and read for the furnishing of Underground Electric Distribution Construction Services.

Instructions for submitting bids and complete specifications will be available in the Office of the Purchasing Technician, Greenville Utilities Commission, 401 S. Greene Street, Greenville, North Carolina during regular office hours, which are 8:30AM – 5:00PM Monday through Friday.

Greenville Utilities Commission reserves the right to reject any or all bids.

SECTION I

GENERAL INSTRUCTIONS FOR FORMAL BIDS

RELATED TO UNDERGROUND ELECTRIC DISTRIBUTION

CONSTRUCTION SERVICES

1.0 NOTICE TO BIDDERS

Sealed bids, subject to the conditions made a part hereof, will be received in the Office of the Purchasing Technician, Greenville Utilities Commission, 401 S. Greene Street, Greenville, North Carolina 27834 until 2:00 PM (EDST) on the day of opening. **Bids submitted in a fax or e-mail in response to this Invitation for Bids will not be acceptable.**

2.0 STANDARD FORMS REQUIRED

Each bidder must submit a proposal on the enclosed bid forms. **The bid must be signed by an authorized official of the firm. Return only the attached Proposal Form. Do not return the Advertisement for Bids, Instructions to Bidders or Specifications.**

3.0 PREPARATION OF BID

Bids must be in sealed envelopes clearly marked on the outside with the name of the bid and the bid opening date and time. Bid shall be addressed to PURCHASING TECHNICIAN, GREENVILLE UTILITIES COMMISSION, 401 S. GREENE STREET, GREENVILLE, NORTH CAROLINA 27834.

4.0 TIME FOR OPENING BIDS

Bids will be opened promptly and read at the hour and on the date set forth in the advertisement in the Office of the Purchasing Technician, Greenville Utilities Main Office, 401 S. Greene Street, Greenville, North Carolina 27834. Bidders or their authorized agents are invited to be present.

5.0 DEPOSIT

A deposit is **NOT** required for this bid.

6.0 NC SALES TAX

Do **not** include NC sales taxes in bid figure; however, Greenville Utilities Commission (GUC) does pay sales tax. Sales tax should be added to the invoice as a separate item.

7.0 FEDERAL EXCISE TAX

GUC is exempt from Federal Excise Tax and will issue a Federal Exemption Certificate upon request to the successful bidder.

8.0 EXCEPTIONS TO BE CLEARLY STATED

If bid is not in strict accordance with Section II, "Specifications," bidder must list or note all exceptions **on the Request for Proposal Form**, otherwise, it is fully understood that the successful bidder will furnish equipment and/or materials exactly as specified. GUC reserves the right to accept or reject bids with noted minor deviations from specifications and to determine the lowest responsible, responsive bid from the standpoint of quality, performance, and price.

9.0 EVALUATION AND AWARD OF BIDS

GUC reserves the right to reject any and all bids, to waive any and all informalities, and to disregard all nonconforming or conditional bids or counter proposals. In evaluating bids, GUC shall consider whether the bids comply with the prescribed requirements, plus all alternates or options requested. GUC reserves the right to include or exclude any option or alternative in GUC's opinion is in GUC's best interests. If a bid is to be awarded, it will be awarded to the lowest responsible, responsive bidder whose evaluation by GUC indicates that the award will be in GUC's best interests. Only firm prices will be considered for award of this bid.

10.0 PROMPT PAYMENT DISCOUNTS

Bidders are urged to compute all discounts into the price offered. If a prompt payment discount is offered, it may be considered in the award of the contract.

11.0 NUMERICAL ERRORS

In the case of a discrepancy between a unit price and the extension (the unit price multiplied by the number of units), the unit price governs. In the case where numerical bids are stated both in numbers and in words, the words govern.

12.0 BID WITHDRAWAL

A bidder must notify GUC in writing of its request to withdraw a bid within seventy-two (72) hours after the bid opening, not including Saturdays, Sundays, or holidays. In order to justify withdrawal, the bidder must demonstrate that a substantial error exists and that the bid was submitted in good faith.

13.0 MINORITY BUSINESS PARTICIPATION PROGRAM

GUC has adopted an Affirmative Action and Minority and Women Business Enterprise Plan (M/WBE) Program. Firms submitting a proposal are attesting that they also have taken affirmative action to ensure equality of opportunity in all aspects of employment, and to utilize M/WBE suppliers of materials and/or labor.

14.0 DELIVERY TIME

Delivery time is to be stated and will be considered in the evaluation of bids if applicable.

15.0 CONTRACT PERIOD

It is the intent of Greenville Utilities Commission (GUC) to enter into a multi-year contract at the time the contract is awarded by GUC to the successful bidder for a total contract period not to exceed four (4) years. **Prices shall remain fixed during the first year** with option for annual extensions at the same or negotiated unit prices for up to four (4) additional years if market, service conditions and fund(s) availability, so warrant and prove to be in the best interest of GUC.

16.0 CONTACT INFORMATION

Questions regarding this bid request should be directed to Jeff Byrd, Electric Distribution Engineer at (252) 551-1568, byrdwj@guc.com, Cleve Haddock, Purchasing Technician at (252) 551-1533, haddocgc@guc.com

17.0 TERMS AND CONDITIONS

The attached Terms and Conditions of the Greenville Utilities Commission (GUC) is considered a part of the bid proposal.

[Balance of page left blank intentionally]

SECTION II

GREENVILLE UTILITIES COMMISSION

TECHNICAL SPECIFICATIONS FOR UNDER GROUND ELECTRIC DISTRIBUTION

CONSTRUCTION SERVICES

NOVEMBER 20, 2013

General Description

The Contractor is to supply labor, tools and equipment necessary to constitute a crew capable of independently installing or replacing underground power cable/conduits and associated equipment in residential and commercial developments. Crew makeup, typical job tasks and other specific requirements are outlined in the following paragraphs:

Material

Materials are to be supplied by Greenville Utilities (GUC) and are to be picked up by the Contractor at the GUC Operations Center on Mumford Road. Materials used for site restoration or repairs for damage caused by the Contractor shall be provided by the Contractor.

Underground Construction (UG)

Job Tasks

Place 15 KV primary cables, secondary cables, conduits, secondary pedestals, pad-mounted transformers, switching equipment, and other facilities typical to URD systems Contractor is to utilize conventional digging equipment (backhoes and trenchers) to install cables and conduits at an average depth of 3' minimum to 5' maximum. Work will typically be billed on a cost basis. Contractor shall provide four-person crew consisting of a foreman, equipment operator, and two (2) semi-skilled laborers

[Balance of page left blank intentionally]

Basic Equipment

Basic equipment shall be assigned to each crew for daily immediate use while performing project work for GUC. Basic equipment shall remain available on system while crews are assigned work for GUC.

One ton crew cab with minimum tools and equipment: (maximum age 10 years)

Crew-Cab

Cable cutter-25" fiberglass handles	Cable cutter-18" fiberglass handles
Cable cutter-hand ratchet	Compression tool 5/8 and "D" die 840
First aid kit 24 pc	Fire extinguisher
Insulated ratchet 3/8"	Insulated extension 6" x 3'8"
Insulated hex bit 1/4" x 3/8"	Insulated hex bit 3/8" x 3/8"
Insulated hex bit 5/16" x 3/8"	Insulated hex bit 7/16" x 3/8"
Insulated socket 3/4" x 3/8"	Insulated socket 1/2" x 3/8"
Insulated socket 9/16" x 3/8"	Insulated socket 5/8" x 3/8"
Ladder 16 ft fiberglass	Phase rotation meter
1000 volt multi-meter	20 kv rubber gloves and protector
PVC saw 18"	Shovel round tip nylon handle
Shovel flat tip nylon handle	Sledge hammer 5 lb
Soil probe, insulated	Fiberglass shot-gun stick universal 8 ft
Fiberglass elbow puller 6 ft	Stripper 4x4 1/0, 2/0, 4/0, 350
Traffic cones (7)	Traffic vest(2)
Transformer wrench, penta	Voltage tester, (tic tracer)
Manhole hook	Tool bag
Lineman pliers klein 9ne	Cannel lock pliers 12"
6 ft folding rule	#2 x 8" flat blade screw driver
#2 x 8" Phillips screw driver	1/2" x 9/16" ratchet wrench
5/8" x 3/4" ratchet wrench	Skinning knife
Elbow probe torque wrench	8" adjustable wrench
10" adjustable wrench	2 lb hammer

Knuckle Boom truck with minimum lifting capacity rated at no less than 98,000 foot-pounds, (maximum age 10 years)

Cable cutter-25" fiberglass handles	Cable cutter-18" fiberglass handles
Cable cutter-hand ratchet	Compression tool 5/8 and "D" die 840
First aid kit 24 pc	Fire extinguisher
Insulated ratchet 3/8"	Insulated extension 6" x 3'8"
Insulated hex bit 1/4" x 3/8"	Insulated hex bit 3/8" x 3/8"
Insulated hex bit 5/16" x 3/8"	Insulated hex bit 7/16" x 3/8"
Insulated socket 3/4" x 3/8"	Insulated socket 1/2" x 3/8"
Insulated socket 9/16" x 3/8"	Insulated socket 5/8" x 3/8"
Ladder 16 ft fiberglass	Phase rotation meter
1000 volt multi-meter	20 kv rubber gloves and protector
PVC saw 18"	Shovel round tip nylon handle
Shovel flat tip nylon handle	Sledge hammer 5 lb
Soil probe, insulated	Fiberglass shot-gun stick universal 8 ft
Fiberglass elbow puller 6 ft	Stripper 4x4 1/0, 2/0, 4/0, 350
Traffic cones (10)	Traffic vest(2)

Transformer wrench, penta
 Manhole hook
 Lineman pliers klein 9ne
 6 ft folding rule
 #2 x 8" Phillips screw driver
 5/8" x 3/4" ratchet wrench
 Elbow probe torque wrench
 10" adjustable wrench
 Digging bar 1 1'8" x 8'
 Hydraulic hammer 45 lb
 Post hole digger 8'
 Rake 18' nylon handle
 Sign 48" utility work ahead (2)
 Sling, transformer 1/2" 2-leg
 Pulling block, 2" x 8" 5000lb (2)

Voltage tester, (tic tracer)
 Tool bag
 Cannel lock pliers 12"
 #2 x 8" flat blade screw driver
 1/2" x 9/16" ratchet wrench
 Skinning knife
 8" adjustable wrench
 2 lb hammer
 Ground rod adapter 5/8"
 Hydraulic tamp jumping jack
 Cable spiking tool
 Reel thing (swivel) RT40
 Sling, eye-eye 1' x 3'
 Sling, transformer, 3/4" x 4 leg

Backhoe - Backhoe with four wheel drive with minimum digging depth of 10 feet. A trailer for the transport of a backhoe. (Maximum age 10 years)

Trencher - Trencher capable of trenching 6" wide x 48" deep with backhoe attachment. A trailer for transport of a trencher. (Maximum age 10 years)

Digger Derrick - 20,000 lb. 45 ft. sheave (Maximum age 10 years)

Cable cutter-25" fiberglass handles
 Cable cutter-hand ratchet
 First aid kit 24 pc
 Insulated ratchet 3/8"
 Insulated hex bit 1/4" x 3/8
 Insulated hex bit 5/16" x 3/8"
 Insulated socket 3/4" x 3/8"
 Insulated socket 9/16" x 3/8"
 Ladder 16 ft fiberglass
 1000 volt multi-meter
 PVC saw 18"
 Shovel flat tip nylon handle
 Soil probe, insulated
 Fiberglass elbow puller 6 ft
 Traffic cones (10)
 Transformer wrench, penta
 Manhole hook
 Lineman pliers klein 9ne
 6 ft folding rule
 #2 x 8" Phillips screw driver
 5/8" x 3/4" ratchet wrench
 Elbow probe torque wrench
 10" adjustable wrench
 Digging bar 1 1'8" x 8'
 Hydraulic hammer 45 lb
 Post hole digger 8'
 Rake 18' nylon handle

Cable cutter-18" fiberglass handles
 Compression tool 5/8 and "D" die 840
 Fire extinguisher
 Insulated extension 6" x 3'8"
 Insulated hex bit 3/8" x 3/8"
 Insulated hex bit 7/16" x 3/8"
 Insulated socket 1/2" x 3/8"
 Insulated socket 5/8" x 3/8"
 Phase rotation meter
 20 kv rubber gloves and protector
 Shovel round tip nylon handle
 Sledge hammer 5 lb
 Fiberglass shot-gun stick universal 8 ft
 Stripper 4x4 1/0, 2/0, 4/0, 350
 Traffic vest(2)
 Voltage tester, (tic tracer)
 Tool bag
 Cannel lock pliers 12"
 #2 x 8" flat blade screw driver
 1/2" x 9/16" ratchet wrench
 Skinning knife
 8" adjustable wrench
 2 lb hammer
 Ground rod adapter 5/8"
 Hydraulic tamp jumping jack
 Cable spiking tool
 Reel thing (swivel) RT40

Sign 48" utility work ahead (2)
Sling, transformer 1/2" 2-leg
Pulling block, 2" x 8" 5000lb (2)

Sling, eye-eye 1' x 3'
Sling, transformer, 3/4" x 4 leg

****Refer to Appendix A, page 28, 1.0 Basic Equipment.***

Supplemental Equipment - Supplemental equipment shall be available for use on GUC system within seven days notice.

*Wet Saw - Capable of cutting 7" deep concrete/asphalt

*Core Drill - Capable of cutting 7" hole 12" deep concrete

*Trench Box - Adjustable width 8'x12'

*Compact backhoe - Compact backhoe 30HP, Front Loader, 4WD, Digging Depth of 7'.

*Cable reel trailer - Single reel cable trailer 4000 lb /reel

*Cable reel trailer - Three reel cable trailer 4000 lb /reel

*Track Hoe – 30HP, Front Backfill Blade, Digging Depth of 8'

Supervision

In order to ensure compliance to Greenville Utilities' Standard Practices, the crew leader will be provided detailed construction plans for each job prior to commencement of work. In addition, the job site will be staked by GUC personnel and visited frequently to monitor progress and assure quality control. The Contractor is responsible to see that 48 hours notice is provided to the Utilities Locating Company (1-800-632-4949) prior to each new assignment. As such, close coordination between the crew leader and GUC Operations personnel will be required.

Existing Facilities

Contractor will be responsible for damages to any utilities or customer-owned facilities caused by its forces. All electric lines in the area, either overhead or underground, are to be considered energized and treated as such unless grounded and tagged by GUC personnel. All high voltage terminations and connections will be performed by GUC personnel.

Job Site Safety

Job site activities shall at all times be conducted in accordance with the North Carolina Occupational Safety and Health Standards, the National Electrical Safety Code, APPA Safety Manual, and the North Carolina Manual on Uniform Traffic Control Devices for Streets and Highways.

Housekeeping

Contractor shall at all times keep the site free of accumulations of waste materials or trash caused by his work force. At the completion of work at each job site, Contractor shall remove all tools and surplus materials and leave site in satisfactory condition.

Crew

Contractor shall ensure that at all times he has sufficient crew in terms of numbers and experience to perform the work completely and safely. A minimum of three workers is required at all times. Crew members shall at all times maintain a neat appearance and a respectful demeanor to the public. Crew shall consist of the following:

Foreman	Experience in all aspects of underground electric distribution construction including cable and conduit installation, cable pulling, transformer installation and termination, secondary pedestal installation and termination, switch gear installation and termination, and primary switching pedestal installation and termination. Ability to operate proficiently all equipment assigned and associated with crew. Ability to read and interpret construction plans. Certified competent person.
Equipment Operator	Working knowledge of the underground electric distribution construction. Understanding of the principles associated with underground electric distribution systems, including cable and conduit installation, cable pulling, transformer installation and termination, secondary pedestal installation and termination, switch gear installation and termination, and primary switching pedestal installation and termination. Ability to proficiently operate all equipment assigned and associated with crew. Ability to lead crew in the absence of Foreman. Certified competent person.
Semi-skilled Laborer	Basic understanding of underground construction principles specifically digging with backhoes and trenchers, installing cables and conduits, setting equipment bases to grade and level. Ability to learn the operation of equipment assigned and associated with crew.

Contractor's Insurance

The contractor shall submit proof of Comprehensive General Liability Insurance carried in the minimum amount of \$1,000,000, written on an "occurrence" basis. A Broad Form Property Damage Endorsement must be attached to the policy. Automobile Liability Insurance in the minimum amount of \$1,000,000 must be carried and proof of same submitted to Greenville Utilities with the execution of the contract for the procurement of labor. The Provider shall provide and maintain Workers' Compensation Insurance, as required by the laws of North Carolina, as well as employer's liability coverage with minimum limits of \$1,000,000, covering the Provider and all employees who are engaged in any work under the contract. If any work is sublet, the Provider shall require the subcontractor to provide the same coverage for any of his employees engaged in any work under the contract.

Work Week

The workweek will consist of 40 hours maximum, to take place during GUC's normal working hours. These hours run from 7:00 a.m. to 5:30 p.m., Monday through Friday excluding holidays as shown on the attached holiday schedule.

***Refer to Appendix B, page 29-30, 2.0 Digging, Trenching, Cable and Conduit Units**
DIGGING, TRENCHING, CABLE AND CONDUIT UNITS (ITEMS XI THRU XXXVII)

*11	TR-42	Trenching average 6" wide X 42" deep	1 ft/unit
*12	BH-42	Back Hoe ditch average 18" X 42"	1 ft/unit
*13	Duct-1	Install 1" PVC conduit in ditch	1 ft/unit
*14	Duct-2	Install 2" PVC conduit in ditch	1 ft/unit
*15	Duct-3	Install 3" PVC conduit in ditch	1 ft/unit
*16	Duct-4	Install 4" PVC conduit in ditch	1 ft/unit
*17	Duct-5	Install 5" PVC conduit in ditch	1 ft/unit
*18	Duct-6	Install 6" PVC conduit in ditch	1 ft/unit
*19	TPX-6	Install #6 triplex in ditch	1 ft/unit
*20	TPX-2/0	Install 2/0 triplex in ditch	1 ft/unit
*21	TPX-4/0	Install 4/0 triplex in ditch	1 ft/unit
*22	TPX-350	Install 350 mcm triplex in ditch	1 ft/unit
*23	TPX-4/0P	Install 4/0 triplex in 2" pvc conduit	1 ft/unit
*24	TPX-4/0P2	Install 2-4/0 triplex in 4" pvc conduit	1 ft/unit
*25	TPX-350P	Install 350 mcm triplex in 3" pvc conduit	1 ft/unit
*26	TPX-350P2	Install 2-350 mcm triplex in 5" pvc conduit	1 ft/unit
*27	QPX-4/0P	Install 4/0 quadraplex in 3" pvc conduit	1 ft/unit
*28	QPX-4/0P2	Install 2-4/0 quadraplex in 4" pvc conduit	1 ft/unit
*29	QPX-350P	Install 350 quadraplex in 4" pvc conduit	1 ft/unit
*30	QPX-350P2	Install 2-350 mcm quadraplex in 5" pvc conduit	1 ft/unit
*31	QPX-350P3	Install 3-350 mcm quadraplex in 6" pvc conduit	1 ft/unit
*32	15kv-1/0	Install 1-1/0 220 mil 15 kv cable in 2" pvc conduit	1 ft/unit
*33	15kv-1/0-2	Install 2-1/0 220 mil 15 kv cable in 3" pvc conduit	1 ft/unit
*34	15kv-1/0-3	Install 3-1/0 220 mil 15 kv cable in 4" pvc conduit	1 ft/unit

*35	15kv-750	Install 1-750 220 mil 15 kv cable in 4" pvc conduit	1 ft/unit
*36	15kv-750-3	Install 3-750 220 mil 15 kv cable in 6" pvc conduit	1 ft/unit
*37	15kv-1000	Install 1-1000 220 mil 15 kv cable in 4" pvc conduit	1 ft/unit

UNDERGROUND APPARATUS AND DEVICE UNITS (ITEMS XXXVIII THRU XXXXXVI)

38	UP1-2EC	Install pad to grade and level	\$/each
39	UP1-4EC	Install pad to grade and level	\$/each
40	SEC-PED	Install secondary pedestal and 3 connectors	\$/each
41	UM1-3EC	Install single phase primary junction	\$/each
42	UM2-2EC	Install three phase primary junction	\$/each
43	UG1-3EC	Install single phase primary riser	\$/each
44	UG1-4EC	Install two phase primary riser	\$/each
45	UG2-2EC	Install three phase primary riser	\$/each
46	UG5-1EC	Install single phase open point padmount XMFR	\$/each
47	UG5-2EC	Install single phase radial padmount XMFR	\$/each
48	UG5-3EC	Install single phase feed thru padmount XMFR	\$/each
49	UG3-5000	Install 3 phase padmount XMFR up to 5000 lbs	\$/each
50	UG3-15000	Install 3 phase padmount XMFR 5k to 15k lbs	\$/each
51	UG4-PM9	Install padmounted switch gear #9 configuration	\$/each
52	UGE-600	Install 600 amp elbow	\$/each
53	UGE-200	Install 200 amp elbow	\$/each
54	UGT-1/0	Install terminator on 1/0 220 mil primary cable	\$/each
55	UGT-750	Install terminator on 750 220 mil primary cable	\$/each
56	GR-20	Install 20 ft ground rod, 1-8 ft and 1 12 ft.	\$/each

SUBMIT BIDS ON ATTACHED PROPOSAL FORM

GREENVILLE UTILITIES COMMISSION

PROPOSAL FORM

The undersigned bidder hereby declares that it has carefully examined the enclosed detailed specifications for furnishing GUC with the services listed below. The undersigned bidder further agrees, if this quote is accepted within sixty (60) days from the date of the opening, to furnish any or all of the services upon the quoted prices.

ITEM NO.	ESTIMATED LABOR AND EQUIPMENT	DESCRIPTION	UNIT PRICE	TOTAL COST
		Contractor shall provide labor rates based on actual salaries paid to employees plus their overhead factor.		
		<u>TYPE (UG) JOB TASKS:</u>		
		<u>MIN./HOUR</u> <u>MAX./HOUR</u>		
	1	Foreman	\$ _____	
	1	Operator	\$ _____	
	2	Semi-Skilled Laborer	\$ _____	
		SUBTOTAL MAX./HOUR		\$ _____
		% Overhead Factor: _____		\$ _____
	1	Pickup	\$ _____	
	1	Knuckle Boom	\$ _____	
	1	Backhoe	\$ _____	
	1	Trencher	\$ _____	
	1	Digger Derrick	\$ _____	
		Subtotal Equipment Rates		\$ _____
		(UG) Job Tasks		\$ _____
		GRAND TOTAL:		\$ _____

Method of Award:

Payment for (UG) Job Tasks shall be rendered as cost plus overhead basis. Estimated hours are 1000 hours. Bid will be awarded based on the lowest cost of the total maximum hourly rates plus overhead plus the hourly equipment rates.

Estimated hours are based on potential workload and available funding.

Complete and Check All Math: It is the responsibility of the Bidder to supply a total for all items.

Please provide at least three (3) references with contact information:

[Balance of page left blank intentionally]

E-VERIFY:

The below Affidavit must be completed and returned with the proposal submission.

AFFIDAVIT

STATE OF NORTH CAROLINA

GREENVILLE UTILITIES COMMISSION

NOW COMES Affiant, first being sworn, deposes and says as follows:

1. I have submitted a bid for contract or desire to enter into a contract with the Greenville Utilities Commission;

2. As part of my duties and responsibilities pursuant to said bid and/or contract, I attest that I am aware of and in compliance with the requirements of E-Verify, Article 2 of Chapter 64 of the North Carolina General Statutes, to include (mark which applies):

___ After hiring an employee to work in the United States I verify the work authorization of said employee through E-Verify and retain the record of the verification of work authorization while the employee is employed and for one year thereafter; or

___ I employ less than twenty-five (25) employees in the State of North Carolina.

3. As part of my duties and responsibilities pursuant to said bid and/or contract, I attest that to the best of my knowledge any subcontractors employed as a part of this bid and/or contract are in compliance with the requirements of E-Verify, Article 2 of Chapter 64 of the North Carolina General Statutes, to include (mark which applies):

___ After hiring an employee to work in the United States the subcontractor verifies the work authorization of said employee through E-Verify and retains the record of the verification of work authorization while the employee is employed and for one year thereafter; or

Employ less than twenty-five (25) employees in the State of North Carolina.
Specify subcontractor: _____

This the _____ day of _____, 2013.

Affiant

Sworn to and subscribed before me, this the _____ day of _____, 2013.

[OFFICIAL SEAL] _____
_____, Notary Public

My Commission Expires: _____

MEMORANDUM

TO: All Employees
DATE: September 14, 2012
SUBJECT: 2013 HOLIDAY SCHEDULE

The following holidays will be observed by the City of Greenville and Greenville Utilities Commission during 2013:

New Year's	Tuesday, January 1, 2013
Martin Luther King, Jr. Day	Monday, January 21, 2013
Good Friday	Friday, March 29, 2013
Memorial Day	Monday, May 27, 2013
Independence Day	Thursday, July 4, 2013
Labor Day	Monday, September 2, 2013
Veterans Day	Monday, November 11, 2013
Thanksgiving	Thursday, November 28, 2013 Friday, November 29, 2013
Christmas	Tuesday, December 24, 2013 Wednesday, December 25, 2013
New Year's (2014)	Wednesday, January 1, 2014

This information is being provided now in order to allow you to make personal plans for the use of the holidays.

dr

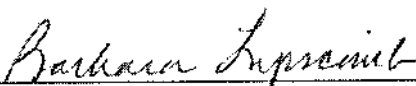

Barbara Lipscomb
City Manager



Anthony C. Cannon
GUC General Manager/CEO

SECTION III
SERVICES AGREEMENT

This Services Agreement (“Agreement”), made and entered into on this the ____ day of _____, 2013 by and between GREENVILLE UTILITIES COMMISSION OF THE CITY OF GREENVILLE, PITT COUNTY, NORTH CAROLINA, with one of its principal offices and places of business at 401 S. Greene Street, Post Office Box 1847, Greenville, Pitt County, North Carolina 27835-1847, hereinafter referred to as “GUC” and _____, a _____ corporation, with one of its principal offices and places of business at _____, hereinafter referred to as “PROVIDER”.

1.0 GUC’s REQUEST FOR PROPOSAL

The Provider’s performance of the services set forth in Section II shall be in accordance with the requirements and this Agreement.

2.0 SERVICES

Provider, as an independent contractor, agrees to perform during the term of this Agreement, each and every service set forth in Section II “Specifications for Grading and Earthwork for Dickinson Avenue Substation.”

3.0 STANDARD OF SKILL

Provider and Provider’s staff, if any, is skilled to perform the work agreed to be done pursuant to this Agreement. GUC relies upon the skill of the Provider and Provider’s staff, if any, to do and perform such work in a skillful manner.

4.0 INDEPENDENT CONTRACTOR

Provider is retained and employed by GUC only to the extent set forth in this Agreement, and the Provider’s relationship to GUC is that of an independent contractor. Provider shall not be considered to have the status of an employee under this Agreement or be entitled to participate in any insurance, medical care, vacation, sick leave, or other benefits provided for GUC’s officers and employees.

5.0 AFFIRMATIVE ACTION

The Provider will take affirmative action in complying with all Federal and State requirements concerning fair employment and employment of the handicapped, and concerning the treatment of all employees, without discrimination by reason of race, color, religion, sex, national origin, or physical handicap.

6.0 CONTRACT PERIOD

This Agreement shall be for a one (1) year period. Based on mutual agreement between the parties, this agreement may be renewed for additional annual renewal extensions, not exceeding a total four (4) year contract term. The pricing for annual renewal will be subject to

the mutual agreement between the parties and will be adjusted for price escalation/de-escalation based on the Consumer Price Index.

7.0 TAXES

No taxes shall be included in any bid prices. GUC is exempt from Federal Excise Tax. GUC is not exempt from North Carolina state sales and use tax or, if applicable, Pitt County sales and use tax. Such taxes shall be shown as a separate item on the invoice.

8.0 INVOICES

Applicable North Carolina sales tax shall be invoiced as a separate line item. All invoices must bear the GUC purchase order number. Mail all invoices to Greenville Utilities Commission, Finance Department, P. O. Box 1847, Greenville, NC 27835-1847.

9.0 PROGRESS REPORTING AND PAYMENT

Provider shall submit invoices to GUC on a monthly basis for services rendered to the date thereof. Such invoices shall be supported by appropriate documentation based upon on agreed percent completion of each Item of the project. A retainage of 10% will be held until final acceptance by Greenville Utilities upon completion of the project. GUC's normal payment policy is thirty (30) days. Payment will be made in U.S. currency only. GUC shall give Provider prompt written notice of disputed items in an invoice and shall pay Provider the undisputed portion of the invoice.

10.0 INDEMNITY PROVISION

Provider agrees to indemnify and save GREENVILLE UTILITIES COMMISSION of the City of Greenville, Pitt County, North Carolina, and the City of Greenville, North Carolina, its co-owners, joint venturers, agents, employees, and insurance carriers harmless from any and all losses, claims, actions, costs, expenses including reasonable attorney fees, judgments, subrogations, or other damages resulting from injury to any person (including injury resulting in death), or damage (including loss or destruction) to property of whatsoever nature of any person arising out of or incident to the performance of the terms of this Contract by Provider, including, but not limited to, Provider's employees, agents, subcontractors, and others designated by Provider to perform work or services in, about, or attendant to, the work and services under the terms of this Contract. Provider shall not be held responsible for any losses, expenses, claims, subrogations, actions, costs, judgments, or other damages, directly, solely, and proximately caused by the negligence of Greenville Utilities Commission of the City of Greenville, Pitt County, North Carolina. Insurance covering this indemnity agreement by the Provider in favor of Greenville Utilities Commission of the City of Greenville, Pitt County, North Carolina, and the City of Greenville, North Carolina, shall be provided by Provider.

11.0 MEDIATION ARBITRATION

In the event of any dispute between the Parties, the Parties agree to submit any dispute to non-binding mediation before a mutually agreeable Mediator prior to initiating litigation. If the Parties are unable to agree upon a Mediator within thirty (30) days after demand therefore, either Party may petition a Court of competent jurisdiction for the designation of a qualified Mediator for these purposes. Each Party shall bear its own costs and expenses of participating in the mediation (including, without limitation, reasonable attorneys' fees), and each Party shall bear

one-half (1/2) of the costs and expenses of the Mediator. Unless otherwise agreed, the Parties will hold the mediation in Greenville, North Carolina. The matters discussed or revealed in the mediation session shall not be disclosed in any subsequent litigation.

In the event the matter is not resolved in mediation, either Party may request arbitration. The parties shall jointly select an Arbitrator, and shall be bound by the decision of the Arbitrator with respect to any dispute between the parties with respect to this Agreement. If the parties are unable to mutually agree upon an Arbitrator, the Parties shall each select an Arbitrator, and the two Arbitrators so selected shall select a third Arbitrator, and the decision of the majority of the Arbitrators shall be conclusive and binding upon the Parties. The Parties at all times agree to equally split the costs of any Arbitrator(s) selected in an effort to resolve the dispute between the Parties. Any party desiring to resolve a dispute under the terms of this Agreement shall notify the other Party in writing, and the Parties shall seek to agree upon a mutually agreed-upon Arbitrator within a period of ten (10) days from the date of such written demand. If the Parties are unable to agree within such ten (10) day period, the Parties shall each select an Arbitrator, and the two (2) Arbitrators so selected shall select a third Arbitrator within fifteen (15) days from the date of the written demand for arbitration, and a decision shall be rendered by the Arbitrator(s) so selected within five (5) days after such Arbitrator(s) is selected.

12.0 COST OF LITIGATION

If any legal action is necessary to enforce any provision of this Agreement or for damages by reason of an alleged breach of any provisions of this Agreement, the prevailing party shall be entitled to receive from the losing party all costs and expenses in such amount as the court may determine to be reasonable. In awarding the cost of litigation, the court shall not be bound by any court fee schedule, but shall, if it is in the interest of justice to do so, award the full amount of actual costs and expenses and reasonable attorneys' fees paid or incurred in good faith.

13.0 TERMINATION OF AGREEMENT

GUC or Provider may terminate this Agreement for just cause at any time. Provider will be paid for all time and expenses incurred as of the termination date. Termination for just cause by either party shall be by certified letter and shall be effective thirty (30) days after signed and acknowledged receipt of said letter. Just cause shall be based on reasonable grounds, and there must be a fair and honest cause or reason for such action. The causes for termination, include, but are not limited to: (1) Provider's persistent failure to perform in accordance with the Terms and Conditions, (2) Provider's disregard of laws and regulations related to this transaction, and/or (3) Provider's substantial violation of the provisions of the Terms and Conditions, (4) Provider's failure to perform in accordance with the scope of work as outlined in Section II, or (5) Provider's failure to follow GUC's policies and procedures.

14.0 SAFETY REQUIREMENT

GUC reserves the right to issue restraint or cease and desist orders to the Provider when unsafe or harmful acts are observed or reported relative to the performance of the work under this Agreement. Any hazardous condition noted by the Provider, which is not the result of its operations, shall immediately be reported to GUC.

15.0 **INSURANCE**

15.1 Coverage – During the term of the contract, the Provider at its sole cost and expense shall provide commercial insurance of such type and with the following coverage and limits:

15.1.1 Workers' Compensation – The Provider shall provide and maintain Workers' Compensation Insurance, as required by the laws of North Carolina, as well as employer's liability coverage with minimum limits of \$1,000,000 each accident, covering all Provider's employees who are engaged in any work under the contract. If any work is sublet, the Provider shall require the subcontractor to provide the same coverage for any of its employees engaged in any work under the contract.

15.1.2 General Liability – Commercial Liability Coverage written on an "occurrence" basis in the minimum amount of \$1,000,000 per occurrence.

15.1.3 Automobile – Automobile Liability Insurance, to include coverage for all owned, hired, and non-owned vehicles used in connection with the contract with a minimum combined single limit of \$1,000,000 per accident.

15.2 Requirements - Providing and maintaining adequate insurance coverage is a material obligation of the Provider. All such insurance shall meet all laws of the State of North Carolina. Such insurance coverage shall be obtained from companies that are authorized to provide such coverage and that are authorized to do business in North Carolina by the Commissioner of Insurance. The Provider shall at all times comply with the terms of such insurance policies and all requirements of the insurer under any of such insurance policies, except as they may conflict with existing North Carolina laws or this contract. The limits of coverage under each insurance policy maintained by the Provider shall not be interpreted as limiting the Provider's liability and obligations under the contract. It is agreed that the coverage as stated shall not be canceled or changed until thirty (30) days after written notice of such termination or alteration has been sent by registered mail to GUC's Purchasing Technician.

15.3 Miscellaneous Insurance Requirement.

15.3.1 Recovery from Provider's Insurance. Provider agrees that in the event of loss due to any of the perils for which it has agreed to provide insurance, the Provider shall look solely to its insurance for recovery.

15.3.2 Failure to Secure. If Provider at any time during the term of this Agreement, should fail to secure or maintain any insurance required under this Agreement, GUC shall be permitted to obtain such insurance in the Provider's name or as an agent of the Provider and GUC shall be compensated by the Provider for the cost of the insurance premiums at the maximum rate permitted by law computed from the date written notice is received that the premiums have been paid. Such costs can be assessed by deducting such costs from any amounts due and payable to the Provider as compensation under the terms of this Agreement.

15.3.3 Additional Insured. The naming of an additional insured shall not affect any recovery to which such additional insured would be entitled under this policy if not named as an additional insured, and an additional insured named under this Agreement shall not be held liable for any premium or expense of any nature on this policy or any extension thereof. Any other insurance held by an additional insured shall not be required to contribute toward any loss or expense covered by the insurance provided by this policy. Proceeds from any policy or policies shall be payable to GUC primarily, and to the Provider secondarily, if necessary.

15.3.4 Evidence of Insurance. If requested by GUC, Provider shall furnish Certificates of Insurance evidencing the required coverages or the original of the insurance policies for review by GUC's Purchasing Technician.

16.0 CONFIDENTIALITY

Provider acknowledges and agrees that in the course of the performance of the services pursuant to this Agreement, Provider may be given access to, or come into possession of, confidential information of GUC which may contain trade secrets, proprietary data, privileged material, or other confidential information. Provider acknowledges and agrees, except if required by law or by judicial or administrative order, trial, or other governmental proceeding pertaining to this matter, that it will not use, duplicate, or divulge to others any such information, including without limitation, trade secrets belonging to or disclosed to Provider by GUC without first obtaining written permission from GUC. "Confidential information" as used herein, includes information developed during this Agreement. All tangible embodiments of such information shall be delivered to GUC by Provider upon termination hereof, or upon request by GUC, whichever first occurs. GUC acknowledges Provider has the right to maintain its own set of work papers which may contain confidential information.

Confidentiality requirements shall not apply where (a) the information is, at the time of disclosure by the Provider, then in the public domain; (b) the information is known to the Provider prior to obtaining the same from GUC; (c) the information is obtained by the Provider from a third party who did not receive the same directly or indirectly, from the GUC or who received it from the GUC without breach of this Agreement; or (e) the information is subpoenaed by court order or other legal process, but in such event, Provider shall notify GUC, who, at its sole cost and discretion, may seek to quash such demand. Provider's obligations of confidentiality shall be binding for a period of three (3) years from the earlier of termination of the Agreement or the completion of Provider's Services.

17.0 ASSIGNMENT

No assignment of the Provider's obligations or the Provider's right to receive payment hereunder shall be permitted without the express written consent of GUC, provided however, upon written request approved by the GUC Purchasing Technician or designee, solely as a convenience to the Provider, GUC may:

- Forward the Provider's payment check directly to any person or entity designated by the Provider, and
- Include any person or entity designated by Provider as a joint payee on the Provider's payment check.
- In no event shall such approval and action obligate GUC to anyone other than the Provider, and the Provider shall remain responsible for fulfillment of all contract obligations.

18.0 INTEGRATED CONTRACT

This Agreement together with the GUC's Request for Proposal, and Provider's response thereto, represents the entire and sole agreement between the Parties with respect to the subject matter hereof and supersedes any and all prior negotiations, understandings, representations, or consulting agreements whether written or oral. This Agreement cannot be modified, changed, or amended, except in writing signed by the Parties.

19.0 NUISANCE

Provider shall not maintain, commit, or permit the maintenance or commission of any nuisance in connection with the performance of services under this Agreement.

20.0 PERMITS AND LICENSES

Provider, at its sole expense, shall obtain and maintain during the term of this Agreement, all appropriate permits, licenses, and certificates that may be required in connection with the performance of services under this Agreement.

21.0 CONFLICT OF INTEREST

Provider agrees to be familiar with and comply with all applicable federal, state, and local conflict of interest laws.

22.0 WAIVER

The failure of either Party to require performance by the other of any provision hereof shall in no way affect the right to require performance at any time thereafter, nor shall the waiver of a breach of any provision hereof be taken to be a waiver of any succeeding breach of such provision or as a waiver of the provision itself. A waiver by GUC of any breach of any term, covenant, or condition contained in this Agreement shall not be deemed to be a waiver of any subsequent breach of the same or any other term, covenant, or condition contained in this Agreement whether of the same or different character.

23.0 RELATIONSHIP

Nothing herein contained shall be construed to imply a joint venture, partnership, or principal-agent relationship between Provider and GUC; and neither Party shall have the right, power, or

authority to obligate or bind the other in any manner whatsoever, except as otherwise agreed to in writing.

24.0 SEVERABILITY

If any provision of this Agreement is declared invalid or unenforceable, such provision shall be deemed modified to the extent necessary and possible to render it valid and enforceable. In any event, the unenforceability or invalidity of any provision shall not affect any other provision of this Agreement, and this Agreement shall continue in force and effect, and be construed and enforced, as if such provision had not been included, or had been modified as above provided, as the case may be.

25.0 GOVERNING LAW

This Agreement shall be governed by, and construed in accordance with, the laws of the State of North Carolina.

26.0 AVAILABILITY OF FUNDS

Any and all payments of compensation of this specific transaction, and any continuation or any renewal or extension, are dependent upon and subject to the allocation of GUC funds for the purpose set forth in this agreement.

27.0 ADMINISTRATIVE CODE

Bids, proposals, and awards are subject to applicable provisions of the North Carolina Administrative Code.

28.0 EXECUTION

In the discretion of GUC, failure of a duly authorized official of Provider to sign the Signatory Page may render the bid/contract invalid.

29.0 CLARIFICATIONS/INTERPRETATIONS

Questions regarding this Services Agreement must be addressed to the Purchasing Technician.

30.0 SITUS

The place of all contracts, transactions, agreements, their situs and forum, shall be North Carolina, where all matters, whether in contract or tort, relating to the validity, construction, interpretation, and enforcement shall be determined.

31.0 FORCE MAJEURE

Neither party shall be considered in default in the performance of its obligations hereunder to the extent that the performance of any such obligation is prevented or delayed by any cause, existing or future, which is beyond the reasonable control of such party. In any such event of force majeure, the parties shall advise each other of such event, and the parties shall negotiate an equitable adjustment to their respective obligations under this Agreement.

32.0 CONTRACT PROVISIONS

Each of the provisions of this Services Agreement shall apply to the full extent permitted by law, and the invalidity in whole or in part of any provision shall not affect the remainder of such provision or any other provisions.

33.0 GOVERNMENT RESTRICTIONS

In the event any Governmental restrictions may be imposed which would necessitate alteration of the material, quality, workmanship, or performance of the items/services offered on this bid prior to their delivery, it shall be the responsibility of the successful Provider to notify the Purchasing Technician, at once, indicating in its letter the specific regulation which required such alterations. GUC reserves the right to accept any such alterations, including any price adjustments occasioned thereby, or, in the sole discretion of GUC, to cancel the contract.

34.0 PATENTS AND COPYRIGHTS

The Provider shall hold and save GUC, its officers, agents, and employees, harmless from third-party liability, including costs and expenses, including reasonable attorney fees, on account of any copyrighted articles or any patented or unpatented invention, device or appliance manufactured or used in the performance of this contract, violating the rights in patent or copyright of a third party.

35.0 PATENT AND COPYRIGHT INDEMNITY

The Provider will defend or settle, at its own expense, any action brought against GUC to the extent that it is based on a claim that the product(s) provided pursuant to this agreement infringe any U.S. copyright or patent; and will pay those costs, damages, and attorney fees finally awarded against GUC in any such action attributable to any such claim, but such defense, settlements, and payments are conditioned on the following: (1) that Provider shall be notified

promptly in writing by GUC of any such claim; (2) that Provider shall have sole control of the defense of any action on such claim and of all negotiations for its settlement or compromise; (3) that GUC shall cooperate with Provider in a reasonable way to facilitate the settlement of defense of such claim; (4) that such claim does not arise from GUC modifications not authorized by the Provider or from the use of combination of products provided by the Provider with products provided by GUC or by others; and (5) should such product(s) become, or in the Provider's opinion likely to become, the subject of such claim of infringement, then GUC shall permit Provider, at Provider's option and expense, either to procure for GUC the right to continue using the product(s), or replace or modify the same so that it becomes non-infringing and performs in a substantially similar manner to the original product.

36.0 LIMITATIONS

Neither party shall be liable to the other party for loss of profits or revenue; loss of use; loss of opportunity; loss of goodwill; cost of substitute facilities, good or services; cost of capital; cost of replacement power; governmental and regulatory sanctions; and claims of customers for such damages; or for any special, consequential, incidental, indirect or exemplary damages. The warranties, obligations, liabilities and remedies of the parties, as provided herein, are exclusive

and in lieu of any others available at law or in equity. Provider's total aggregate liability under this Agreement shall not exceed the compensation received by Provider under this agreement. To the fullest extent allowed by law, releases from, waivers of, and limitations of liability shall apply notwithstanding the breach of contract, tort including negligence, strict liability or other theory of legal liability of the party released or whose liability is limited.

37.0 NOTICES

Notices to the Parties should be sent to the names and addresses specified below:

Cleve Haddock
Finance/Purchasing, Buyer II
Greenville Utilities Commission
P.O. Box 1847
Greenville, NC 27835-1847

Jeff Byrd
Electric Distribution Engineer
Greenville Utilities Commission
P.O. Box 1847
Greenville, NC 27835-1847

Vendor Specified on Page 1 of Section III when awarded.

[Balance of page left blank intentionally]

GREENVILLE UTILITIES COMMISSION

By: _____
Anthony C. Cannon

Title: General Manager/CEO
(Authorized Signatory)

Date: _____

Attest: _____

Name (Print): Amy Carson Quinn

Title: Executive Secretary

Date: _____

(OFFICIAL SEAL)

COMPANY NAME:

By: _____

Name (Print): _____

Title: _____
(Authorized Signatory)

Date: _____

Attest: _____

Name (Print): _____

Title: Corporate Secretary

Date: _____

(CORP. SEAL)

This instrument has been pre-audited in the manner required by the Local Government Budget and Fiscal Control Act.

By: _____
Jeff W. McCauley

Title: Chief Financial Officer

Date: _____

APPROVED AS TO FORM AND LEGAL CONTENT:

By: _____
Phillip R. Dixon

Title: Commission Attorney

Date: _____

APPENDIX A

PRICING NOT CONSIDERED FOR THE BID EVALUATION

I.0 Basic Equipment

Item	Equipment	Total Cost
1	Directional Boring Machine	_____
2	Vacuum System	_____
3	Wet saw	_____
4	Core Drill	_____
5	Trench Box	_____
6	Compact Backhoe	_____
7	Cable reel trailer (single reel)	_____
8	Digger Derrick	_____

PLEASE NOTE: These prices will not be considered for the bid evaluation; however, prices must be submitted for future reference.

[Balance of page left blank intentionally]

2.0 Digging, Trenching, Cable and Conduit Units (APPENDIX B)

ITEM	UNIT #	DESCRIPTION	COST PER FT/UNIT
1	TR-42	Trenching Average 6" wide x 42" deep	
2	BH-42	Back Hoe ditch average 18" x 42"	
3	Duct-1	Install 1" PVC conduit in ditch	
4	Duct-2	Install 2" PVC conduit in ditch	
5	Duct-3	Install 3" PVC conduit in ditch	
6	Duct-4	Install 4" PVC conduit in ditch	
7	Duct-5	Install 5" PVC conduit in ditch	
8	Duct-6	Install 6" PVC conduit in ditch	
9	TPX-6	Install #6 triplex in ditch	
10	TPX-2/0	Install 2/0 triplex in ditch	
11	TPX-4/0	Install 4/0 triplex in ditch	
12	TPX-350	Install 350 mcm triplex in ditch	
13	TPX-4/0P	Install 4/0 triplex in 2" pvc conduit	
14	TPX-4/0P2	Install 350 mcm triplex in 4" pvc conduit	
15	TPX-350P	Install 350 mcm triplex in 3" pvc conduit	
16	TPX-350P2	Install 2-350 mcm triplex in 5" pvc conduit	
17	QPX-4/0P	Install 4/0 quadraplex in 3" pvc conduit	
18	QPX-4/0P2	Install 2-4/0 quadraplex in 4" pvc conduit	
19	QPX-350P	Install 350 quadraplex in 4" pvc conduit	
20	QPX-350P2	Install 2-350 mcm quadraplex in 5" pvc conduit	
21	QPX-350P3	Install 3-350 mcm quaraplex in 6" pvc conduit	
22	15kv-1/0	Install 1-1/0 220 mil 15kv cable in 2" pvc conduit	
23	15kv-1/0-2	Install 2-1/0 220 mil 15kv cable in 3" pvc conduit	
24	15kv-1/0-3	Install 3-1/0 220 mil 15kv cable in 4" pvc conduit	
25	15kv-750	Install 1-750 220 mil 15kv cable in 4" pvc conduit	
26	15kv-750-3	Install 1-1000 220 mil 15kv cable in 6" pvc conduit	
27	15kv-1000	Install 1-1000 220 mil 15kv cable in 4" pvc conduit	
28	UP1-2EC	Install pad to grade and level	
29	UP1-4EC	Install pad to grade and level	
30	SEC-PED	Install secondary pedestal and 3 connectors	
31	UM1-3EC	Install single phase primary junction	
32	UM2-2EC	Install three phase primary junction	
33	UG1-3EC	Install single phase primary riser	
34	UG1-4EC	Install two phase primary riser	
35	UG2-2EC	Install three phase primary riser	
36	UG5-1EC	Install single phase open point padmount XMFR	
37	UG5-2EC	Install single phase radial padmount XMFR	

ITEM	UNIT #	DESCRIPTION	COST PER FT/UNIT
38	UG5-3EC	Install single phase feed thru padmount XMFR	_____
39	UG3-5000	Install 3 phase padmount XMFR up to 5,000 lbs	_____
40	UG3-15000	Install 3 phase padmount XMFR 5k to 15k lbs	_____
41	UG4-PM9	Install padmounted switch gear #9 configuration	_____
42	UGE-600	Install 600 amp elbow	_____
43	UGE-200	Install 200 amp elbow	_____
44	UGT-1/0	Install terminator on 1/0 220 mil primary cable	_____
45	UGT-750	Install terminator on 750 220 mil primary cable	_____
46	GR-20	Install 20 ft ground rod, 1-8 ft and 1-12 ft	_____

PLEASE NOTE: These prices will not be considered for the bid evaluation; however, prices must be submitted for future reference.

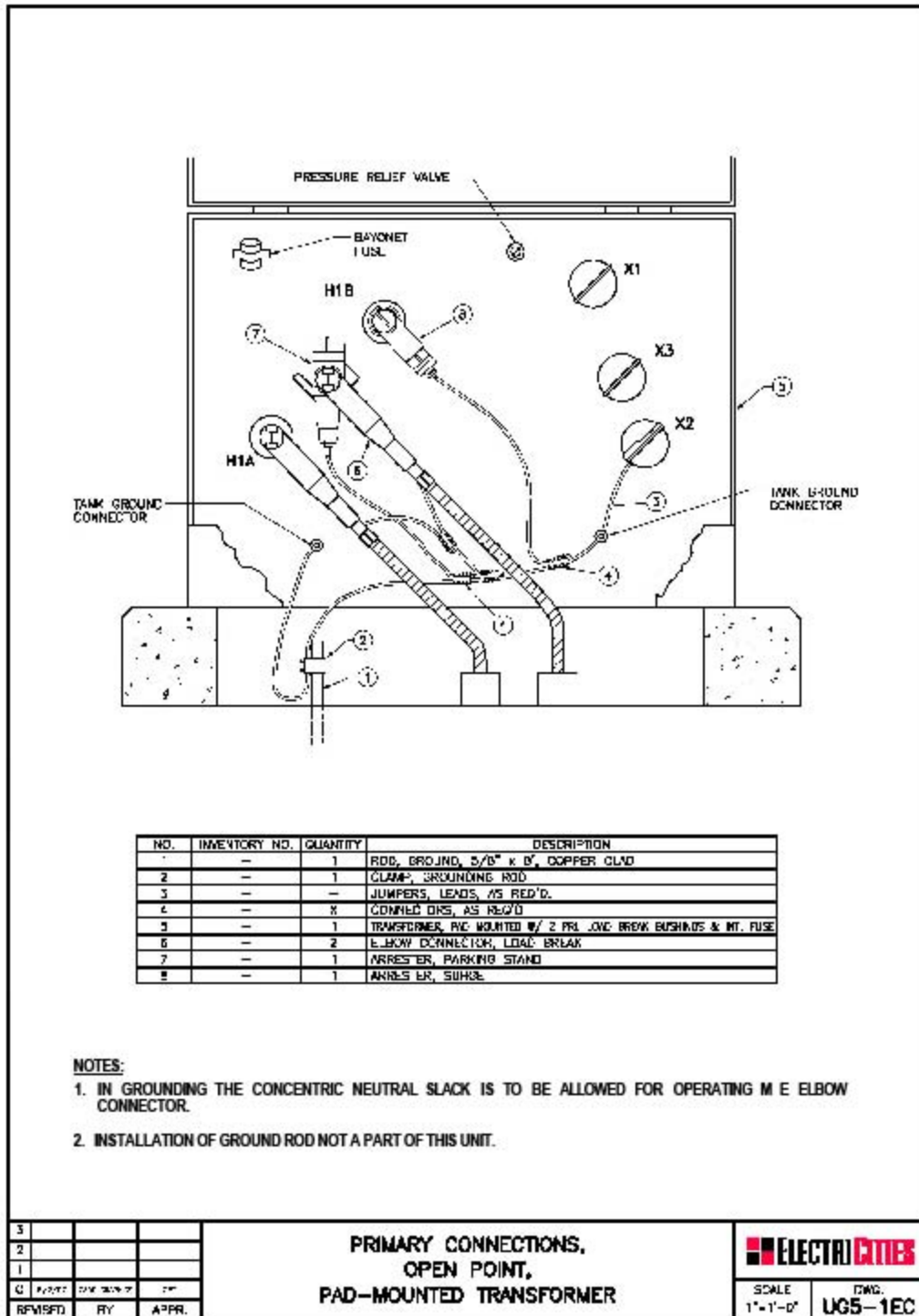

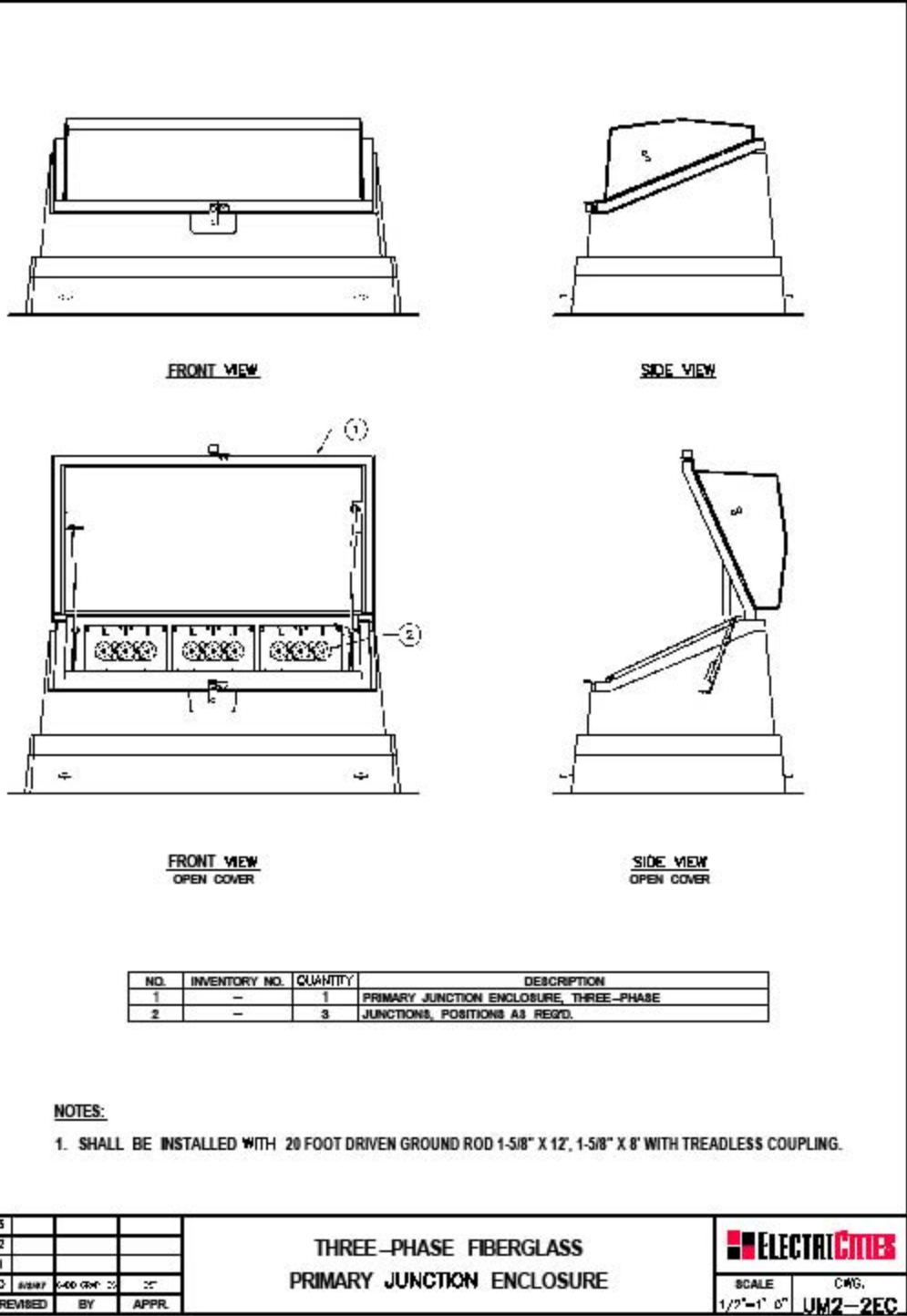

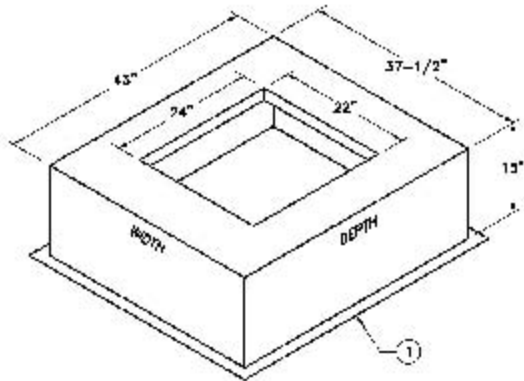

NO.	INVENTORY NO.	QUANTITY	DESCRIPTION
1	-	1	FIBERGLASS TRANSFORMER BOX PAD

NOTES:

1. SHALL BE INSTALLED WITH A 20 FOOT DRIVEN GROUND ROD 1-5/8" X 12', 1-5/8" X 8' WITH TREADLESS COUPLING.
2. DRAWING FOR REPRESENTATION ONLY. ACTUAL DIMENSIONS MAY VARY WITH MANUFACTURER.

3			
2			
1			
Q	1/2" X 12'	20' DRIVEN GROUND ROD	1
RFMSFD	RY	A.P.P.F.	

FIBERGLASS TRANSFORMER BOX PAD
SINGLE-PHASE



SCALE 1/2"=1'-0"
DWG. UP1-2EC

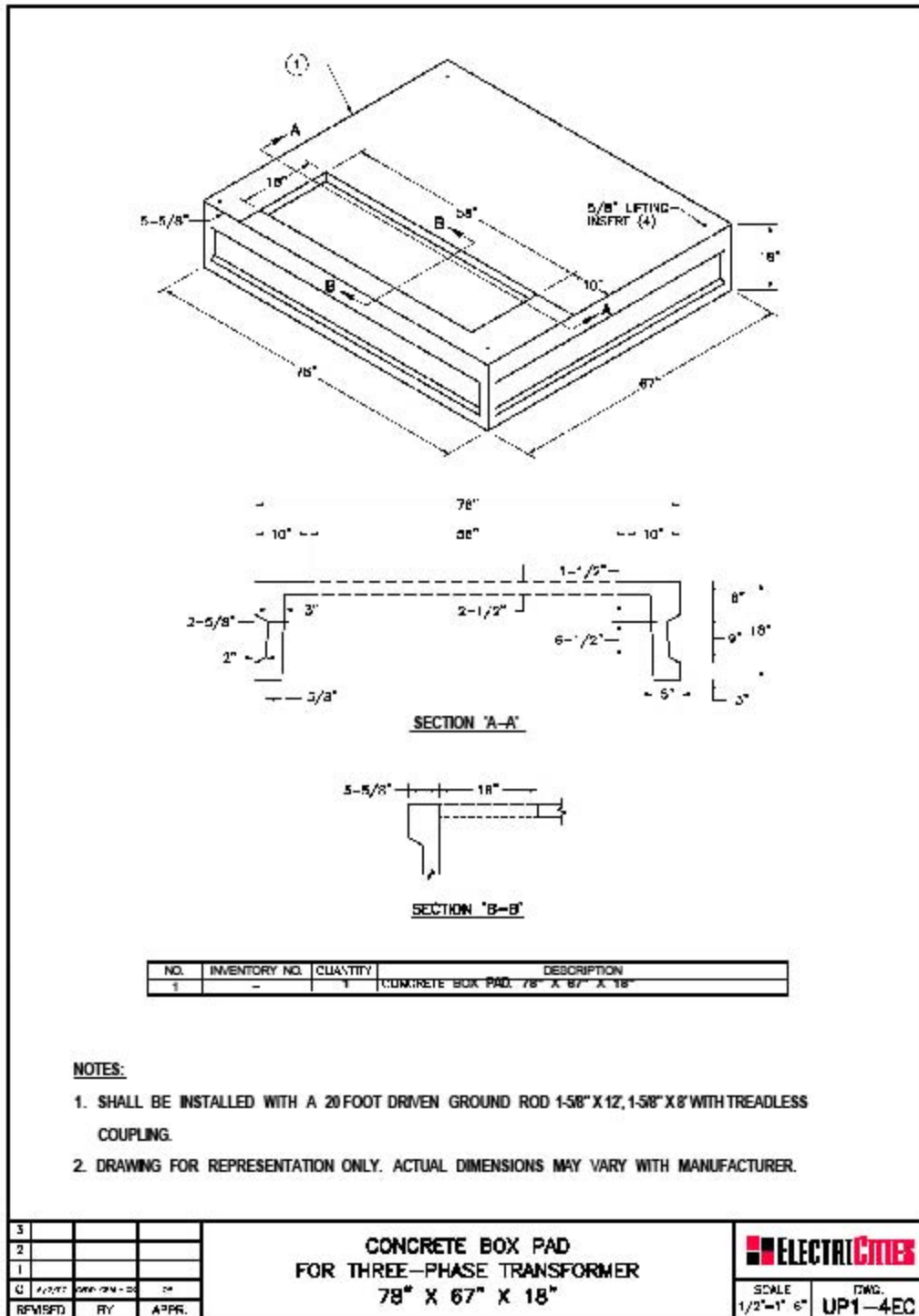

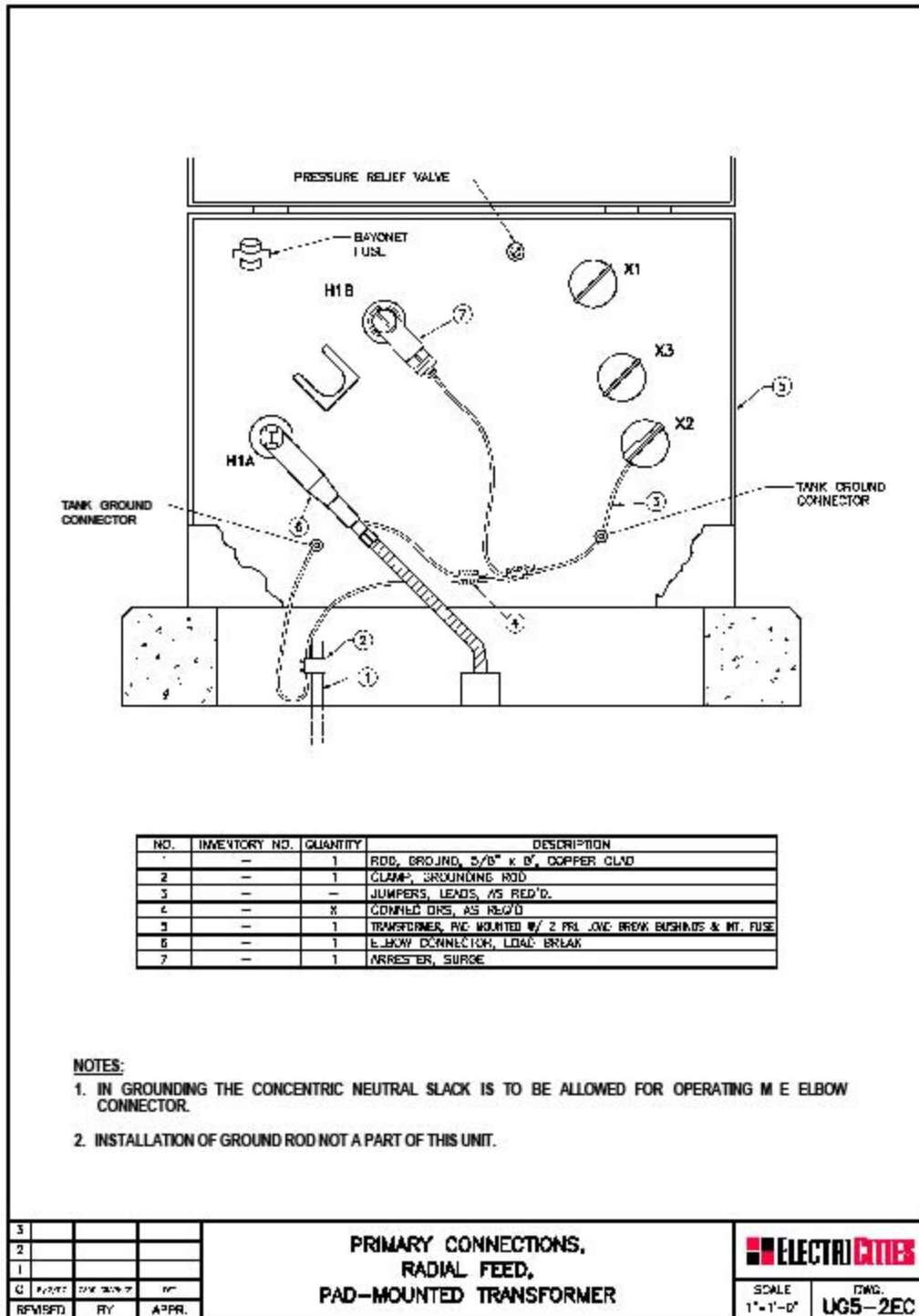

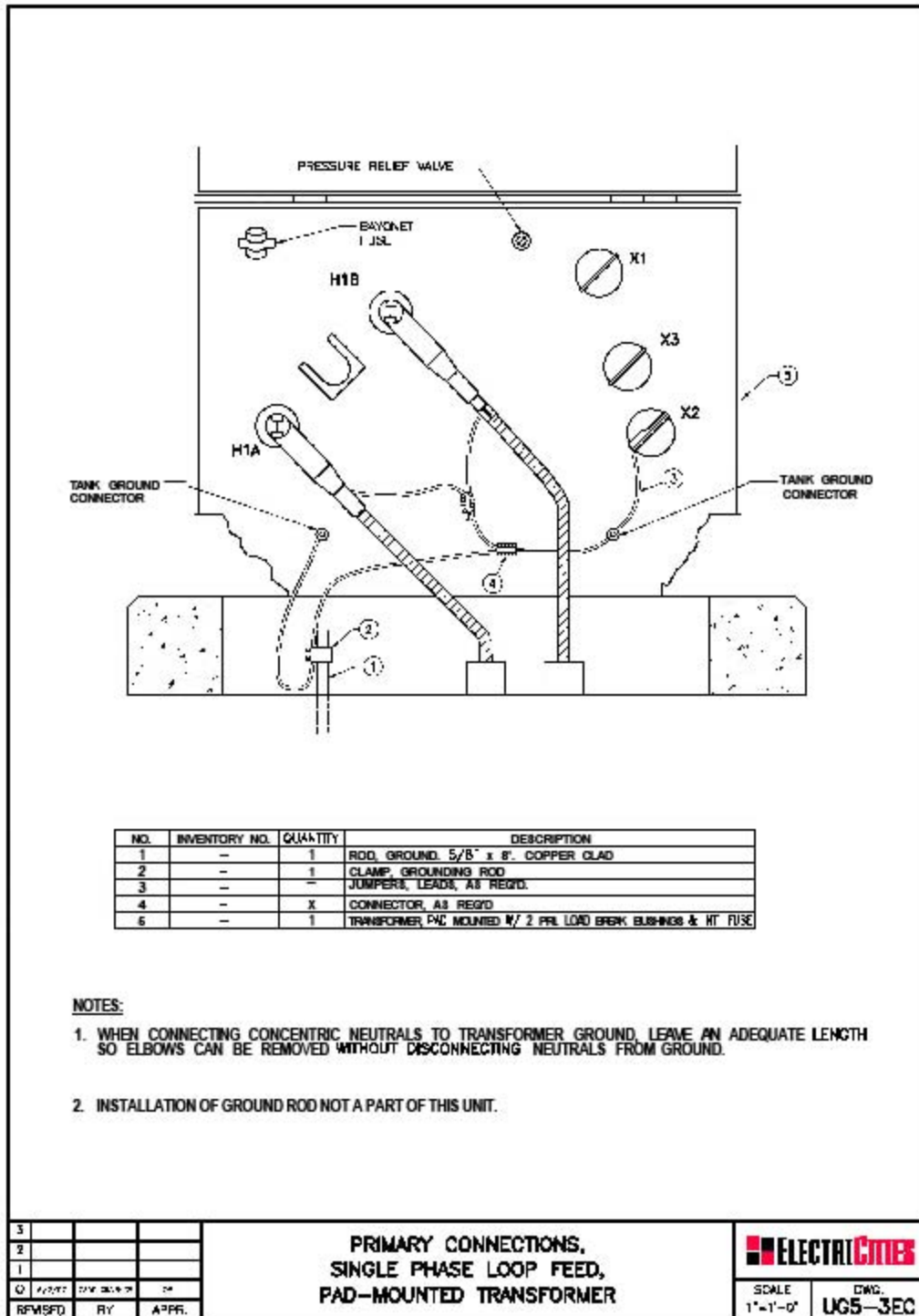

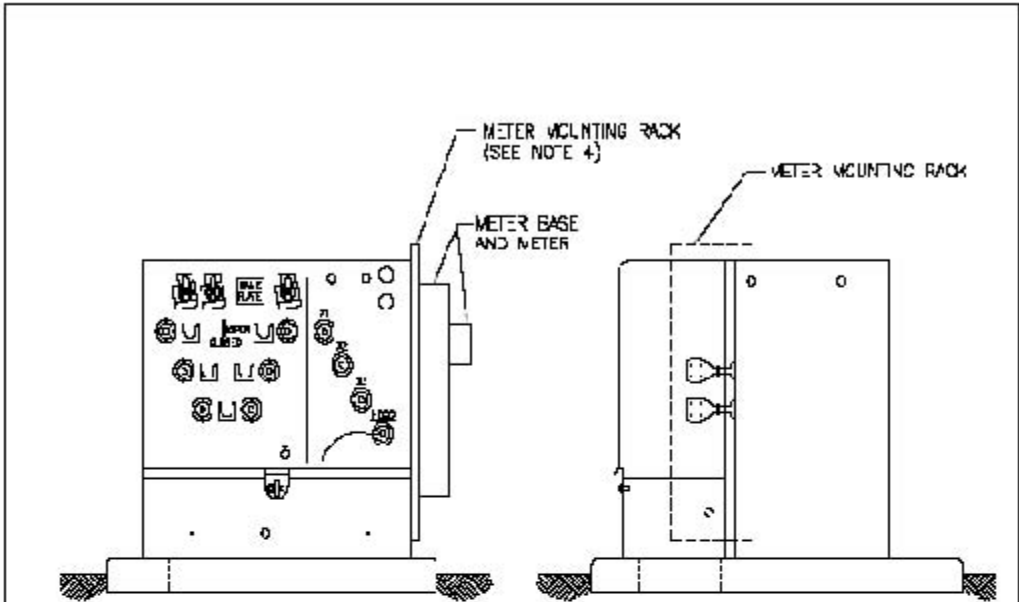

NOTES:

1. THE METER MOUNTING RACK AND METER BOX WILL BE FURNISHED AND INSTALLED BY METERING OPERATIONS.
2. NO PRIMARY CONNECTORS FOR THIS UNIT.

3				
2				
1				
0	DESIGN	ISSUE	REVISION	APPROVAL
	REVISED	BY	CHK'D	APPR

UNDERGROUND PADMOUNT
THREE PHASE TRANSFORMER
UP TO 5000 LBS



CAR

DWG.
UG3-5000

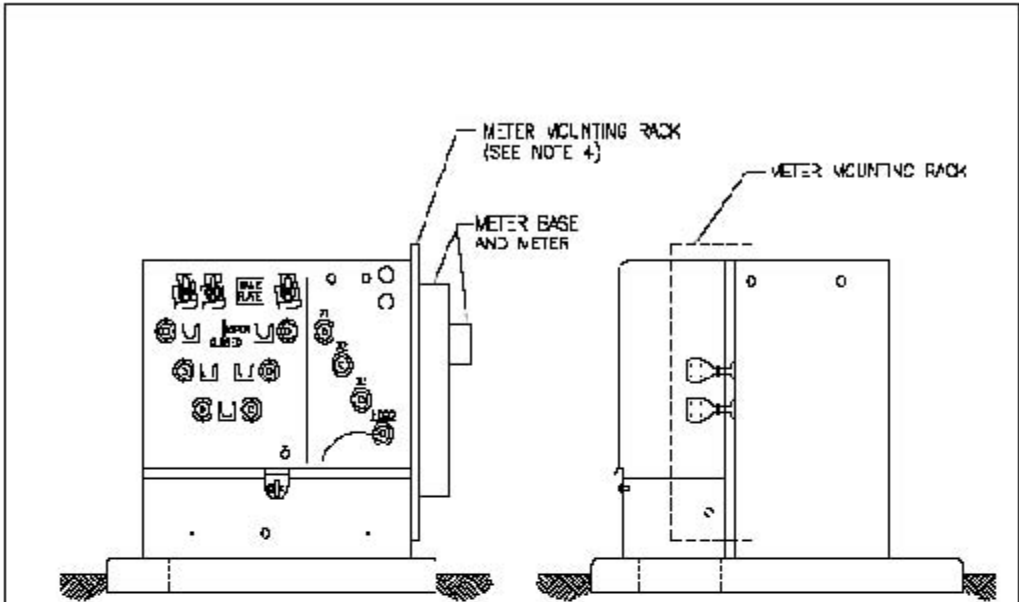

NOTES:

1. THE METER MOUNTING RACK AND METER BOX WILL BE FURNISHED AND INSTALLED BY METERING OPERATIONS.
2. NO PRIMARY CONNECTORS FOR THIS UNIT.

3				
2				
1				
0	DESIGN	ISSUED	REVISION	APPROVAL
	REVISED	BY	CHK'D	APPR

UNDERGROUND PADMOUNT THREE PHASE
TRANSFORMER UP TO 15,000 LBS



CAR

DWG.
UG3-15000

