

ADVERTISEMENT FOR BIDS REV. I

Sealed proposals will be received in the Office of the Procurement Manager, Greenville Utilities Commission, 401 S. Greene Street, Greenville, North Carolina 27834 until 3:00 pm (EDST) on January 27, 2022 and immediately thereafter publicly opened and read for the furnishing of Tubular Steel Structures.

Instructions for submitting bids and complete specifications will be available in the Office of the Procurement Manager, Greenville Utilities Commission, 401 S. Greene Street, Greenville, North Carolina during regular office hours, which are 8:30AM – 5:00PM Monday through Friday.

Greenville Utilities Commission reserves the right to reject any or all bids. **Late bids will not be considered.**

Notice to Bidders:

Greenville Utilities Commission is committed to the health and safety of our customers and employees. We are taking the spread of COVID-19 very seriously and continue to monitor the latest Local, State, and Federal guidance.

SECTION I
GENERAL INSTRUCTIONS FOR FORMAL BIDS
RELATED TO THE PURCHASE OF APPARATUS, SUPPLIES,
MATERIALS, AND EQUIPMENT

1. NOTICE TO BIDDERS

Sealed bids, subject to the conditions made a part hereof, will be received in the Office of the Procurement Manager, Greenville Utilities Commission, 401 S. Greene Street, Greenville, North Carolina 27834 until 3:00 pm (EDST) on January 27, 2022, the day of opening. Bids submitted in a fax or e-mail in response to this Invitation for Bids **will not be acceptable.**

2. STANDARD FORMS REQUIRED

Each bidder must submit a proposal on the enclosed bid forms. **The bid must be signed by an authorized official of the firm. Return only the attached Proposal Form. Do not return the Advertisement for Bids, Instructions to Bidders or Specifications.**

3. PREPARATION OF BID

Bids must be in sealed envelopes clearly marked on the outside with the name of the bid and the bid opening date and time. Bid shall be addressed to PROCUREMENT MANAGER, GREENVILLE UTILITIES COMMISSION, 401 S. GREENE STREET, GREENVILLE, NORTH CAROLINA 27834.

4. TIME FOR OPENING BIDS

Bids will be opened promptly and read at the hour and on the date set forth in the advertisement in the Office of the Procurement Manager, Greenville Utilities Main Office, 401 S. Greene Street, Greenville, North Carolina. Bidders or their authorized agents are invited to be present.

5. BID SECURITY

Each Proposal shall be accompanied by cash, cashier's check, or certified check drawn on a bank insured with the Federal Deposit Insurance Corporation or the Savings Association Insurance Fund, payable to the Owner, in an amount not less than five percent (5%) of the total bid as a guarantee that a Purchase Order, if awarded, will be accepted. In lieu thereof, a Bid Bond may be submitted by the Bidder in an amount not less than five percent (5%) of the total bid.

6. NC SALES TAX

Do **not** include NC sales taxes in bid figure; however, Greenville Utilities Commission (GUC) does pay sales tax. Sales tax should be added to the invoice as a separate item.

7. FEDERAL EXCISE TAX

GUC is exempt from Federal Excise Tax and will issue a Federal Exemption Certificate upon request to the successful bidder.

8. EXCEPTIONS TO BE CLEARLY STATED

If bid is not in strict accordance with Section II, "Specifications," bidder must list or note all exceptions **on the Request for Proposal Form**, otherwise, it is fully understood that the successful bidder will furnish equipment and/or materials exactly as specified. GUC reserves the right to accept or reject bids with noted minor deviations from specifications and to determine the lowest responsible, responsive bid from the standpoint of quality, performance, and price.

9. EVALUATION AND AWARD OF BIDS

GUC reserves the right to reject any and all bids, to waive any and all informalities, and to disregard all nonconforming or conditional bids or counter proposals. In evaluating bids, GUC shall consider whether the bids comply with the prescribed requirements, plus all alternates or options requested. GUC reserves the right to include or exclude any option or alternative in GUC's opinion is in GUC's best interests. If a bid is to be awarded, it will be awarded to the lowest responsible, responsive bidder whose evaluation by GUC indicates that the award will be in GUC's best interests. Only firm prices will be considered for award of this bid.

10. PROMPT PAYMENT DISCOUNTS

Bidders are urged to compute all discounts into the price offered. If a prompt payment discount is offered, it may be considered in the award of the contract.

11. NUMERICAL ERRORS

In the case of a discrepancy between a unit price and the extension (the unit price multiplied by the number of units), the unit price governs. In the case where numerical bids are stated both in numbers and in words, the words govern.

12. BID WITHDRAWAL

A bidder must notify GUC in writing of its request to withdraw a bid within seventy-two (72) hours after the bid opening, not including Saturdays, Sundays, or holidays. In order to justify withdrawal, the bidder must demonstrate that a substantial error exists and that the bid was submitted in good faith.

13. MINORITY BUSINESS PARTICIPATION PROGRAM

GUC has adopted an Affirmative Action and Minority and Women Business Enterprise Plan (M/WBE) Program. Firms submitting a proposal are attesting that they also have taken affirmative action to ensure equality of opportunity in all aspects of employment, and to utilize M/WBE suppliers of materials and/or labor.

14. DELIVERY TIME

Delivery time is to be stated and will be considered in the evaluation of bids. Failure by the successful bidder to meet quoted delivery shall be interpreted as non-compliance with these specifications and may be deemed sufficient cause for removal of the manufacturer and/or distributor from our lists as acceptable manufacturers or bidders.

15. DELIVERY

Shipments will be made only upon individual releases from a blanket purchase order issued by GUC in accordance with GUC's current needs. Time is of the essence with respect to all deliveries under this Agreement. Delivery of all equipment, materials, or supplies shall be made Free on Board (FOB) GUC Warehouse, 701 Utility Way, Greenville, North Carolina 27834, unless otherwise specified. The agreed price for such equipment, materials, or supplies shall include all costs of delivery and ownership, and risks of loss shall not be transferred from Provider to GUC until express written acceptance of delivery and inspection by GUC. Delivery hours are between 8:00 AM and 4:30 PM Tuesday-Thursday only. **GUC's purchase order number is to be shown on the packing slip or any related documents.** GUC reserves the right to refuse or return any delivery with no purchase order number or which is damaged. GUC will not be charged a restocking fee for any delivery which is refused or returned.

16. CONTRACT PERIOD

NA

17. MANUFACTURER

Bidder is to specify the manufacturer of items being quoted if applicable.

18. QUANTITIES

Quantities specified are only estimates of GUC's requirements. GUC reserves the right to purchase more or less than the stated quantities at prices indicated in the submitted Proposal Form based on our actual needs.

19. CONTACT INFORMATION

Questions regarding this bid request should be directed to Cleve Haddock, CLGPO, Procurement Manager, at (252) 551-1533, haddockc@guc.com. **All questions regarding this bid must be received by or before 5:00 pm (EDST) on January 10, 2022.**

20. TERMS AND CONDITIONS

The attached Terms and Conditions apply to all purchases made by Greenville Utilities Commission (GUC) and must be considered as part of the bid proposal.

SECTION II

GREENVILLE UTILITIES COMMISSION

SPECIFICATIONS FOR GALVANIZED TUBULAR STEEL STRUCTURES

JANUARY 27, 2022

STEEL SINGLE POLE, AND H-FRAME STRUCTURES

1. SCOPE

This specification covers the design, materials, welding, inspection, protective coatings, drawings and delivery of steel transmission single pole, three pole, and H-frame structures. The proposal submitted by the manufacturer shall include field bolts, locknuts, vangs, attachment provisions for arms and/or insulators, anchor bolts, base plates, and other necessary items to make a complete structure. .bak files are available upon request.

2. DEFINITIONS:

Cambering - the fabricating of a slight convex curve in a pole or crossarm

D/t - the ratio of the diameter of a tubular pole to the steel plate thickness

Engineer - a registered or licensed person, who may be a staff employee or an outside consultant, and who provides engineering services. Engineer also includes duly authorized assistants and representatives of the licensed person.

Ground Line - a designated location on the pole where the surface of the ground will be after installation of a direct embedded pole

Load factors (LF) - a multiplier which is applied to each of the vertical, transverse and longitudinal structure loads to obtain an ultimate load

P-delta (P-t1) moment - secondary moment created by the vertical loads acting on the structure when the structure deflects from its unloaded position

Point of Fixity - location on the pole at ground line or below ground line where the maximum moment occurs

Pole twist - Spiral rotation of a pole section relative to the pole end. It is caused by the residual stress in the steel as received from the mill, the clamping force holding the tube shells together and the heat applied during the seam welding process.

Raking - the practice of installing a straight pole out of plumb, or at an inclined angle

w/t - ratio of the width of the pole (flat-to-flat) to the plate thickness

Ultimate load - the maximum design load which includes the appropriate load factor specified

3. CODES AND STANDARDS

Codes, standards, or other documents referred to in this specification shall be considered as part of this specification. The following codes and standards are referenced:

- a. American Society of Civil Engineers (ASCE) Standard, Design of Steel Transmission Pole Structures, Manual 72, latest edition.
- b. American Society for Testing and Materials (ASTM), various standards, latest revision.
- c. American Concrete Institute (ACI), Building Code Requirements for Reinforced Concrete, ACI 318, latest edition.
- d. American Welding Society (AWS), Structural Welding Code, AWS D1.1, latest edition.
- e. American National Standards Institute (ANSI), National Electrical Safety Code, ANSI C2, latest edition.
- f. Society for Protective Coatings (SSPC, formerly Steel Structure Painting Council)/ National Association of Corrosion Engineers (NACE) Surface Preparations Specification, SSPC/NACE SP-6/NACE 3.

4. CONFLICT BETWEEN THIS SPECIFICATION, DRAWINGS, AND REFERENCED DOCUMENTS

In the event of conflict between this specification and the above referenced documents, the requirements of this specification shall take precedence. In the case of conflict between several referenced documents, the more stringent requirement shall be followed. If a conflict exists between this specification or the referenced documents and the attached drawings, the attached drawings shall be followed. If clarification is necessary, contact the owner or owner's representative.

5. GENERAL REQUIREMENTS

The design, fabrication, allowable stresses, processes, tolerances, and inspection shall conform to the ASCE Standard, Design of Steel Transmission Pole Structures (Manual 72), latest edition, with the following additions and/or exceptions:

- a. Design
 - (1) Pole designs shall be prepared from the attached Pole Replacement Schedule A and configuration drawings (Attachment B of this Specification). Pole designs shall be 12-sided galvanized steel. The H-frame structure cross arm shall be 8-sided galvanized steel. The H-frame structure mounting strap shall be galvanized steel.

- (2) Wind pressures shown in the loading criteria shall be multiplied by the appropriate shape factor applied to the poles. Pressures in psf shall be computed as follows:

$$p = W \times C_d$$

Where p = pressure on projected area of the pole normal to wind, W = wind pressure, and C_d = shape (or drag) factor.

Shape factors for computing the wind on poles are:

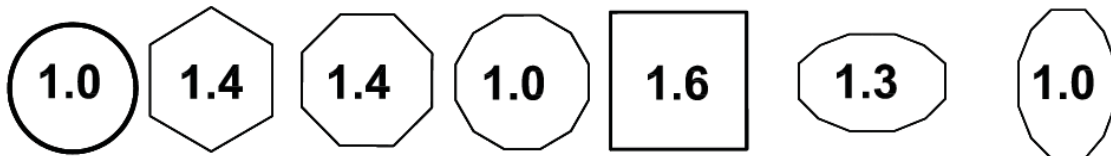

- (3) The maximum design unit stress shall be the minimum yield strength as stated in applicable ASTM specifications for the particular application and types of loads, including load factors.
- (4) Poles shall be designed with a minimum number of joints. Field welding shall not be allowed as part of the design of a new pole. The shaft joints to be made in the field shall be slip joints or bolted flange joints. Slip joint length shall be at least 1-1/2 times the largest inside diameter of the female section. Bolted flange joints shall be used for medium angle and heavy angle guyed structures and cross-braced H-Frames.

Manufacturer shall verify slip joint fit before shipment. Joints should not interfere with joints, step nuts, ladder clips, or jacking nuts.

Sufficient jacking lugs and permanent orientation marks shall be provided at all slip joints to ensure proper alignment and complete overlap of the joint.

- (5) The ultimate load in guys shall not exceed 65 percent of the rated breaking strength of the guy.
- (6) Design of anchor bolts shall be in accordance with the ACI-318-1983 Edition, Building Code Requirements for Reinforced Concrete, assuming a concrete strength as specified by the owner.

When anchor bolts are specified, they shall have the top 2 feet galvanized. Anchor bolts shall be threaded at the top end a distance equal to the baseplate thickness plus the thickness of two anchor bolt nuts plus 2-1/2". Each anchor bolt shall include two heavy hex nuts.

Welding on anchor bolts will only be allowed in the bottom 12 inches. Only one length of anchor bolt shall be used on each pole. Anchor bolts/clusters shall be plainly marked to indicate the structure type, structure number, orientation, and top of concrete.

Anchor bolts shall be designed to be shipped as a rigid cage with top and bottom plates holding the anchor bolts in place. The anchor bolt thread shall be protected during shipping. The anchor bolts shall be welded to the holding plate in the bottom of the cage. The top template shall be designed to be removable and to support the assembled cage during lifting and setting operations without detrimental deformations. Bolt clusters shall be designed to be rigid enough to withstand the normal jolts of shipping, handling and installation with no displacement of bolts from the proper positions within the cluster.

The removable template at the top shall be marked to show the centerline for tangent structures and the angle bisector for angle structures. Matching marks are to be on the base plate of the structure so proper alignment can be made.

- (7) Minimum plate thickness for all pole components shall be 3/16 inch.
- (8) Structures which are to be direct embedded shall have bearing plates and ground sleeves. Bearing plates shall have a diameter not more than 2 inches greater than the maximum pole diameter.

Galvanized poles shall have a drain hole at the bottom. The drain hole shall not be more than 20% of the bottom plate surface area.

Direct embedded steel poles shall have ground sleeves. Ground sleeves shall have a minimum length of 4 feet centered at ground line.

The ground sleeve shall have a minimum thickness of 3/16 inch and shall be centered at the ground line. A seal weld shall be provided around the ground sleeve. The ground sleeve shall not be considered in strength calculations.

- (9) Poles shall have nearly a uniform taper throughout their entire length. The maximum difference in tapers between two pole sections measured by the diameters shall be .20 inch/ft. for poles with variable taper.
- (10) Poles with elliptical cross sections shall have a minor axis dimension equal to at least 75 percent of the major axis dimension.
- (11) All unguyed angle poles or unguyed tangent deadends shall be precambered to remain plumb when the calculated deflection at the top of the pole exceeds 1.5 percent of the pole height under an initial conductor tension loading of 60°F, no wind, and no load factors. Pole height shall be the height of the pole from the top of the baseplate, or designated ground line, to the top. Tangent poles with unbalanced vertical loadings shall be precambered for the previously stated conditions.
- (12) Arms shall be designed so the end of the arm is at the specified height under a loading of initial conductor tension, 60°F, no wind, and no load factors. Arms shall not deflect vertically more than 12 inches at the end of the arm under heavy ice conditions (without any load factors applied).

Arms shall be upswept or straight, tapered, steel tubular members, of any cross-sectional type, which meet the dimensions shown on the attached drawings.

Arm end plate connection details for hardware attachment shall be typical of those shown on the attached drawings. The arms shall be hermetically sealed when a painted finish is specified. Galvanized arms shall have drain holes where appropriate.

- (13) Lifting lugs are optional. The manufacturer shall supply all instructions for handling and erection of poles and arms.
- (14) In the design of connections for vangs, brackets, or stiffeners attached to the pole shaft, care shall be taken to distribute the loads sufficiently to protect the wall of the pole from local buckling.
- (15) Thru-vang shall penetrate both sides of the pole with attachment holes on both sides.
- (16) Each pole shall be permanently marked on the pole shaft 60 inches above ground line and on the bottom of baseplate or bearing plate with the following identifying information: manufacturer's identification, structure type, height, structure number, ultimate groundline moment, owner name, and date manufactured. The method of identification shall be approved by the owner.
- (17) Each steel pole section shall be marked with a weld bead indicating the location of that sections center of gravity.
- (18) Each separate part of steel pole structure shall be marked in accordance with SUPPLIER'S drawings. Marking shall be made by addition of weld metal and shall be clearly legible after finishing.

b. Materials

- (1) All materials shall comply with the applicable requirements of ASTM specifications. Any modifications to ASTM specifications must be approved by the owner's representative prior to bidding.
- (2) Poles, arms and conductor brackets shall conform to ASTM A36, ASTM A572, ASTM 581, ASTM A588, ASTM A871 or ASTM A595.
- (3) Base plate shall conform to ASTM A572, ASTM A588, ASTM A633, or ASTM A595.
- (4) Anchor bolts shall conform to ASTM A615, Grade 60 or 75.
- (5) Other bolts and nuts shall conform, as applicable, to ASTM A307, ASTM A325, ASTM A354, ASTM A394, or ASTM A687. Locknuts shall be provided for each structure bolt, or American Nut Company (ANCO) type self-locking nuts may be used. Locknuts shall be the galvanized MF type or ANCO type.

- (6) Anchor bolts, structural plate, and weld material, shall meet ASCE requirements for Charpy tests.
- (7) For galvanized structures, steel used for the pole shaft and arms shall have a silicon content less than .06 percent.

c. Fabrication

- (1) All welding shall be in accordance with the AWS D1.1, latest edition. Welders shall be qualified in accordance with AWS D1.1 welding procedures.
- (2) One hundred percent penetration welds shall be required in, but not limited to, the following areas:
 - a. circumferential welds (C-welds) joining structural members;
 - b. longitudinal welds in the female portion of the joint within the slip joint area;
 - c. welds at the butt joints of back-up strips; and
 - d. base plate to shaft weld.
 - e. longitudinal welds for a minimum length of 3 inches where there are adjacent C-welds, flange welds, base welds and ends of tubes.
- (3) Full penetration or equivalent 90 percent partial penetration with fillet overlay shall be used for arm-to-arm base, vang-to-plate shaft, and arm box joints.
- (4) Quality and acceptability of every inch of the full penetration welds shall be determined by visual and ultrasonic inspection.
- (5) All other penetration welds shall have 60 percent minimum penetration. Quality and acceptability of all welds other than full penetration welds shall be determined by visual inspection, supplemented by magnetic particle, ultrasonic or dye penetrant inspection.
- (6) All weld back-up strips shall be continuous the full length of the welds. Care shall be exercised in the design of welded connections to avoid areas of high stress concentration which could be subject to fatigue or brittle fractures.
- (7) Field welding shall not be permitted except with owner's approval and the manufacturer's direction in repairing a pole.
- (8) All parts of the structure shall be neatly finished and free from kinks or twists. All holes, blocks, and clips shall be made with sharp tools and shall be clean-cut without torn or ragged edges.
- (9) Before being laid out or worked in any manner, structural material shall be straight and clean. If straightening is necessary, it shall be done by methods that will not damage the metal.

- (10) Shearing and cutting shall be performed carefully and all portions of the work shall be finished neatly. Copes and re-entrant cuts shall be filleted before cutting.
- (11) All forming or bending during fabrication shall be done by methods that will prevent embrittlement or loss of strength in the material being worked.
- (12) Holes for connection bolts shall be 1/16 inch larger than the nominal diameter of the bolts. Holes in the flange plates for bolted splices shall be 1/8 inch larger than the bolt diameter. Holes in the base plates for anchor bolts shall be 3/8 inch larger than the nominal diameter of the anchor bolts. The details of all connections and splices shall be subject to the approval of the owner or his representatives.
- (13) Holes in steel plates which are punched must be smooth and cylindrical without excessive tear out or depressions. Any burrs that remain after punching shall be removed by grinding, reaming, etc.
- (14) Holes of any diameter may be drilled in plate of any thickness. Care shall be taken to maintain accuracy when drilling stacks of plates.
- (15) Holes may be made by use of a machine guided oxygen torch. Flame cut edges shall be reasonably smooth and suitable for the stresses transmitted to them.
- (16) Field drilled holes must be approved by the owner. If the manufacturer is aware of the owner's intent to field drill holes, the manufacture must supply a galvanizing touch-up kit for galvanized poles.

d. Tolerances

Manufacturing tolerances shall be limited to the following:

Pole Length	<u>One piece</u> : ± 2 inches, or ± 1 inch $\pm 1/8$ inch per 10 feet of length, whichever is greater (i.e. - 120 foot pole shall have a length of 120 feet $\pm 2\frac{1}{2}$ inches)
	<u>Assembled pole with flange connections</u> : same as for one piece <u>Assembled pole with slip joint connections</u> : The accumulation of the slip joint tolerances not to exceed $-6''$, $+12''$
Pole Diameter	-0 inch, $+1/4$ inch
Pole End Squareness	$\pm 1/2$ inch per foot of pole diameter
Pole Sweep	1/8 inch per 10 feet of pole length
Pole Twist	Limit twist to $1^\circ/10'$ of length, not to exceed 4° /tube segment. Overall structure twist shall be limited to 10° for embedded and 6° for base plated structures. Connections for all appurtenances to the pole shall account for the pole twist and should align vertically.
Slip Joint tolerances	Tolerances per manufacturer's recommendations and total pole length requirements above.

Location of Groups of Bolt Holes from Top of Pole	± 1.0 inches (tolerance to dimension 'A', Figure 2)	<p>FIGURE 2</p>
Location of Centerline Between Groups of Bolt Holes	± 1.0 inch (tolerance to dimension 'B', Figure 2)	
Location of Holes Within a Group of Bolt Holes	$\pm 1/8$ inch (tolerance to dimension 'C', Figure 2)	
Bolt Hole Alignment	Not to vary from the longitudinal pole centerline of that group of holes by more than 1/16 inch	
Location of Identification Plate	± 2.0 inch	

e. Grounding

- (1) A grounding connection shall be welded to the pole shaft 6 inches above the ground collar. The grounding connection will be either the two-hole NEMA pad, or a nut, or a threaded insert installed in the pole, or an approved alternative.
- (2) Grounding pad face shall not be painted or covered with other coatings. The grounding nut thread and grounding pad threads shall be protected from coatings.
- (3) Poles shall be pre-drilled with a nine-sixteenth inch (9/16") hole behind each threaded hole of a two (2)-hole NEMA pad to permit the use of various bolt lengths in completing a grounding connection.
- (4) Threaded inserts installed for grounding shall be made of Type 316 stainless steel and provided with standard 1/2 inch, 13 UNC threads. Threads shall be protected from coatings.

f. Finishes

- (1) The following finishes are acceptable: galvanizing, zinc primer and painting, and below grade coating.
 - a. Galvanizing - All structures and structural components which are hot-dip galvanized shall meet all the requirements of ASTM A123 or ASTM A153. Measures shall be taken to prevent warping and distortion according to ASTM A384 and to prevent embrittlement according to ASTM A143. Poles made of ASTM A588 steel shall not be galvanized due to the high silicon content of the steel. One gallon of zinc enriched paint shall be provided with each five poles.

b. Coatings for the Embedded Portion of the Pole - When poles are to be directly embedded, a 16 mil (minimum dry film thickness), two component hydrocarbon extended polyurethane coating that is resistant to ultraviolet light shall be applied on the exposed surface of the embedded portion of the pole. The coating shall extend from the butt to the top of the ground sleeve. Other coatings shall be approved by the owner prior to their use.

- (2) Bolts and nuts with yield strengths less than 100,000 psi shall be hot-dip galvanized per ASTM A153 and ASTM A143, or mechanically coated with zinc in accordance with ASTM B454, Class 50. Bolting materials with yield strengths in excess of 100,000 psi shall not be hot-dip galvanized. Instead, they shall be painted with zinc enriched paint or mechanically coated with zinc per ASTM B454, Class 50.
- (3) Compliance with coating thickness requirements shall be checked with a magnetic thickness gauge.

g. Inspection and Testing

- (1) The owner and the owner's designated agents shall have free entry at all times while work is being carried on, to all parts of the manufacturer's plant to inspect any part of the production of the poles covered by this specification.
- (2) Steel members which are bent or warped or otherwise improperly fabricated shall be properly repaired or replaced.
- (3) The cost of tests made by the manufacturer (except full scale load tests on poles), including cost of the certified test reports shall be considered included in the price.
- (4) The manufacturer shall make tests in accordance with ASTM A370 and ASTM A673 verifying that the material used in the structures, meets the impact properties.
- (5) Mill test reports showing chemical and physical properties of all material furnished under this specification shall be maintained by the manufacturer for a period of 5 years and shall be traceable to the structure.
- (6) All plates over 1-1/2 inches thick shall be ultrasonically tested to assure against defects which could lead to lamellar tearing.
- (7) Welders or welding operators shall be qualified in accordance with the provisions of AWS D1.1.
- (8) The manufacturer shall make certified welding reports for each structure. The reports covering welding shall include all welds of each structure. Each weld shall be clearly identified; and the report shall consist of the method of

testing, whether the weld is acceptable, the identification of the structure, the date, and the name and signature of the inspector.

h. Shipping

- (1) Each shipment shall be accompanied by a list of all parts, identifiable by structure type and number. Arms, bolts and miscellaneous hardware will be identified by the list for match up with the respective pole shaft. All parts required for any one structure shall be in one shipment, if possible.
- (2) The owner and owner's representative shall be notified prior to shipment that such shipment is to take place, and they reserve the right to inspect the components prior to shipment. The notification shall give quantities, weight, name of common carrier used, and expected time of arrival with at least two (2) working days' notice of delivery. Delivery of all items of material shall be made at such time as to permit unloading between the hours of 9:00 a.m. and 3:00 p.m., Tuesday through Thursday, holidays excluded.
- (3) The anchor bolts shall be welded to the holding plate in the bottom of the cage. A removable template shall be used at the top of the cage and shall be marked to show the centerline for tangent structures and the angle bisector for angle structures. Matching marks are to be on the base plate so proper alignment can be made. Bolt clusters shall be rigid enough to withstand the normal jolts of shipping and handling with no displacement of bolts from the proper positions within the cluster.
- (4) Unless otherwise agreed to by the owner, the anchor bolt cage shall be shipped at least 30 days prior to pole shipment.
- (5) Salt-treated wood blocking and urethane foams shall not be used when shipping or storing steel poles.
- (6) Delivery shall be made either to a single designated location or to the individual structure locations.

i. Standard Class Designations

- (1) Tangent and guyed angle structures have been specified using RUS Standard Steel Pole Class Designations shown in Table 1 unless noted otherwise.
- (2) Pole designs shall be prepared for the attached Standard Class design loads. The poles shall be designed to meet ASCE Manual No. 48-11, "Design of Steel Transmission Pole Structures," design methods. The point-of-fixity shall be considered to be located at a distance from the pole bottom that is equal to seven percent (7%) of the pole length.

The pole shall be symmetrically designed such that the strength required in any one direction shall be required in all directions about the longitudinal axis.

- (3) Using the corresponding values in Table 1, the poles shall be designed for the following requirements.
 - a. The pole shall develop the minimum ultimate moment capacity required in Table 1 at a distance of five feet (5'-0") from the pole top
 - b. The pole shall develop the minimum ultimate moment capacity above the point-of-fixity that is calculated by multiplying the tip load in Table 1 by the distance to the tip load.
 - c. The geometry and taper of the pole shall be uniform throughout their entire length (top to butt).
- (4) The poles shall be designed to withstand the specified tip loading in Table 1 without exceeding a pole deflection of ten percent (10%) of the pole length above the point-of-fixity when tested in accordance with ASCE Manual No. 48-11.
- (5) Overall length of poles shall be designed and manufactured in incremental lengths of five feet (5'-0").

TABLE 1 – Strength Requirements

Standard Class Designations for Steel Poles	Minimum Ultimate Moment Capacity at 5 ft from Pole Top (ft. Kips)	Horizontal Tip Load Applied 2 ft from Pole Top (lbs.)
S-20.0	160	20000
S-19.0	152	19000
S-18.0	144	18000
S-17.0	136	17000
S-16.0	128	16000
S-15.0	120	15000
S-14.0	112	14000
S-13.0	104	13000
S-12.0	96	12000
S-11.0	88	11000
S-10.0	80	10000
S-09.0	72	9000
S-08.0	64	8000
S-07.4	57	7410
S-06.5	50	6500
S-05.7	44	5655
S-04.9	38	4875
S-04.2	32	4160
S-03.5	27	3510
S-02.9	23	2925
S-02.4	19	2405
S-02.0	15	1950

6. INFORMATION TO BE SUPPLIED BY THE MANUFACTURER

a. Information to be supplied with the proposal (Attachment D of this Specification).

- (1) Calculated shipping weight of each structure excluding anchor bolts. Separate weights shall be given for arms and poles.
- (2) Calculated shipping weight of anchor bolts.
- (3) Ultimate ground line reactions (including load factors) in poles and guy wires.
- (4) Anchor bolt size, length and locations (bolt circle diameters).
- (5) Type of material of major components (ASTM number).
- (6) Description of pole shaft, including thickness, length, diameter, cross-sectional geometry, and method of fastening each shaft component.
- (7) Data showing the design of the arm, arm connections, arm attachment plates and brackets.
- (8) Sketches or draft drawings of structure and structure attachments.

b. Documentation to be supplied for the owner's approval prior to fabrication

Documentation includes final design calculations for pole shaft, base plate, anchor bolts, arms, and other appurtenances, including their connections for all structures. The following information shall be supplied:

- (1) For the loading cases with load factors, the total shear, axial forces, moments, stresses or stress ratios, section moduli, cross-sectional areas, deflections w/t's for polygonal and D/t's for round cross sections at all splices, at arm attachment points (top and bottom), and at least every 10 feet along the pole.
- (2) For the critical loading case, shear and axial forces, moments, stresses, section moduli, cross-sectional areas at the arm connections, bolt stresses in the arm connection, and deflection at the end of the arm.
- (3) Anticipated deflections at the top of the pole and at the ends of the arms shall be indicated for each pole for the normal, everyday loading condition of 60°F, no wind, and no load factors.
- (4) For all specified loading cases, reactions and ground line moments shall be supplied.
- (5) Detail drawings for each structure type giving weights of structure components, dimensions, and bill of materials.
- (6) Assembly instructions and erection drawings. Slip joint lengths and allowable tolerances. Special handling instructions.

- c. Final Documents shall be supplied to the owner for the items in Section 6.b.(5), after erection of all structures and prior to final payment.
- d. Test Reports (as requested).
 - (1) Certified mill test reports for all structural material.
 - (2) Certified welding reports for each structure.
 - (3) Impact property test reports showing that the material used in the structures meets the impact properties.
 - (4) Test reports on coating thickness.
 - (5) Report of structure testing, when required, including photographs, diagrams, load trees, etc.
 - (6) Material, workmanship, inspection travelers, and material certified mill test reports shall be maintained on file for a minimum of six (6) years by the Materialman, and shall be made available to Greenville Utilities Commission or the Engineer upon request at no charge.

7. APPROVAL, ACCEPTANCE, AND OWNERSHIP

- a. Final designs must be approved by the owner or owner's representative before material ordering and fabrication. Material ordering and fabrication prior to approval will be at supplier's risk. It is understood that award of this contract does not constitute acceptance of design calculations submitted with the bid, if corrections are required in the final structure designs due to manufacturer's errors, omissions, or misinterpretations of the specifications, the quoted price shall not change. Approval of the drawings and calculations by the owner or the owner's representative does not relieve the supplier of responsibility for the adequacy of the design, correctness of dimensions, details on the drawings, and the proper fit of parts.
- b. After delivery, the poles will be inspected and shall be free of dirt, oil blisters, flux, black spots, dross, tear-drop edges, flaking paint or zinc; and in general, shall be smooth, attractive, and unscarred. Poles not meeting this requirement shall be repaired or replaced by the fabricator at no additional cost to the owner.
- c. All final drawings shall become the property of the owner, who shall have full rights to reproduce drawings and use them as the owner sees fit, including submitting them to other vendors for the purpose of obtaining bids on future steel pole purchases.

8. LIST OF ATTACHMENTS TO THIS SPECIFICATION

- a. Attachment A, Pole Replacement Schedule
- b. Attachment B, Structure Drawings
- c. Attachment C, Structure Weights and Costs
- d. Attachment D, Bid Summary-Design Information, and Weights

Attachment A, Pole Replacement Schedule

Mt. Pleasant - Sugg Pkwy Transmission				
Structure #	Pole Height (ft.)	Wood Pole Equivalent	RUS Class	Embedment
1	80	ENG	ENG	Concrete Foundation
2	85	H9	S-10.0	Concrete Foundation
3	85	ENG	ENG	Concrete Foundation
4	90	ENG	ENG	Concrete Foundation
5	95	ENG	ENG	Concrete Foundation
6	80	ENG	ENG	Concrete Foundation
7	80	H9	S-10.0	Concrete Foundation
8	80	H10+	S-11.0+	Concrete Foundation
9	75	H8	S-09.0	Concrete Foundation
10	75	H8	S-09.0	Concrete Foundation
11	75	ENG	ENG	Concrete Foundation
12	75	H7	S-08.0	Concrete Foundation
13	75	ENG	ENG	Concrete Foundation
14	80	H10	S-11.0	Concrete Foundation
15	80	H10	S-11.0	Concrete Foundation
16	75	H8	S-09.0	Concrete Foundation
17	75	H7	S-08.0	Concrete Foundation
18	80	ENG	ENG	Concrete Foundation
19	80	H10	S-11.0	Concrete Foundation
20	80	H9	S-10.0	Concrete Foundation
21	90	ENG	ENG	Concrete Foundation
22	100	ENG	ENG	Concrete Foundation
23	95	ENG	ENG	Concrete Foundation
24	80	H8	S-09.0	Concrete Foundation
25	70	ENG	ENG	Concrete Foundation
26	75	H10	S-11.0	Concrete Foundation
27	75	H8	S-09.0	Concrete Foundation
28	80	H10	S-11.0	Concrete Foundation
29	80	H9	S-10.0	Concrete Foundation
30	80	H10	S-11.0	Concrete Foundation
31	75	H8	S-09.0	Concrete Foundation
32	75	H9	S-10.0	Concrete Foundation
33	80	H10	S-11.0	Concrete Foundation
34	80	H10	S-11.0	Concrete Foundation
35	80	ENG	ENG	Concrete Foundation
36	75	H8	S-09.0	Concrete Foundation
37	80	H10	S-11.0	Concrete Foundation
38	75	ENG	ENG	Concrete Foundation
39	75	H7	S-08.0	Concrete Foundation
40	75	ENG	ENG	Concrete Foundation
41	80	H7	S-08.0	Concrete Foundation
42	85	ENG	ENG	Concrete Foundation

Structure #	Pole Height (ft.)	Wood Pole Equivalent	RUS Class	Embedment
43	85	H10	S-11.0	Concrete Foundation
44	80	H8	S-09.0	Concrete Foundation
45	75	ENG	ENG	Concrete Foundation
46	80	ENG	ENG	Concrete Foundation
47	85	H10	S-11.0	Concrete Foundation
48	90	H10	S-11.0	Concrete Foundation
49	85	ENG	ENG	Concrete Foundation
50	80	ENG	ENG	Concrete Foundation
51	95	H10	S-11.0	Concrete Foundation
52	95	ENG	ENG	Concrete Foundation
53	90	H10	S-11.0	Concrete Foundation
54	90	H10	S-11.0	Concrete Foundation
55	95	H10+	S-11.0+	Concrete Foundation
56	95	H10+	S-11.0+	Concrete Foundation
57	85	H10	S-11.0	Concrete Foundation
58	80	H10	S-11.0	Concrete Foundation
59	80	H9	S-10.0	Concrete Foundation
60	80	H10	S-11.0	Concrete Foundation
61	90	ENG	ENG	Concrete Foundation
62	105	ENG	ENG	Concrete Foundation
63	105	ENG	ENG	Concrete Foundation
64	75	ENG	ENG	Concrete Foundation
65	75	ENG	ENG	Concrete Foundation
66	70	H7	S-08.0	Concrete Foundation
67	70	H7	S-08.0	Concrete Foundation
68	70	H10+	S-11.0+	Concrete Foundation
69	70	H6	S-07.4	Concrete Foundation
70	70	H8	S-09.0	Concrete Foundation
71	70	H6	S-07.4	Concrete Foundation
72	70	H9	S-10.0	Concrete Foundation
73	80	H10	S-11.0	Concrete Foundation
74	80	H10	S-11.0	Concrete Foundation
75	80	H10+	S-11.0+	Concrete Foundation
76	80	H8	S-09.0	Concrete Foundation
77	80	H8	S-09.0	Concrete Foundation
78	80	H7	S-08.0	Concrete Foundation
79	80	H9	S-10.0	Concrete Foundation
80	80	H6	S-07.4	Concrete Foundation
81	80	H6	S-07.4	Concrete Foundation
82	80	H6	S-07.4	Concrete Foundation
83	85	H7	S-08.0	Concrete Foundation
84	85	H8	S-09.0	Concrete Foundation
85	80	H10+	S-11.0+	Concrete Foundation
86	75	H7	S-08.0	Concrete Foundation

Structure #	Pole Height (ft.)	Wood Pole Equivalent	RUS Class	Embedment
87	75	H6	S-07.4	Concrete Foundation
88	70	H6	S-07.4	Concrete Foundation
89	70	H6	S-07.4	Concrete Foundation
90	70	H6	S-07.4	Concrete Foundation
91	75	H10	S-11.0	Concrete Foundation
92	70	H6	S-07.4	Concrete Foundation
93	70	H6	S-07.4	Concrete Foundation
94	75	H10	S-11.0	Concrete Foundation
95	70	H6	S-07.4	Concrete Foundation
96	70	H6	S-07.4	Concrete Foundation
97	70	H6	S-07.4	Concrete Foundation
98	75	H7	S-08.0	Concrete Foundation
99	85	ENG	ENG	Concrete Foundation
100	80	ENG	ENG	Concrete Foundation
101	80	ENG	ENG	Concrete Foundation
102	80	ENG	ENG	Concrete Foundation
103	75	H8	S-09.0	Concrete Foundation
104	70	H8	S-09.0	Concrete Foundation
105	70	H4	S-05.7	Concrete Foundation
106	70	H4	S-05.7	Concrete Foundation
107	70	H4	S-05.7	Concrete Foundation
108	70	H5	S-06.5	Concrete Foundation
109	70	H5	S-06.5	Concrete Foundation
110	70	H6	S-07.4	Concrete Foundation
111	75	H8	S-09.0	Concrete Foundation
112	80	H10	S-11.0	Concrete Foundation
113	85	H7	S-08.0	Concrete Foundation
114	90	ENG	ENG	Concrete Foundation
115	90	ENG	ENG	Concrete Foundation
116	85	H7	S-08.0	Concrete Foundation
117	80	H6	S-07.4	Concrete Foundation
118	80	H6	S-07.4	Concrete Foundation
119	90	H10	S-11.0	Concrete Foundation
120	85	H7	S-08.0	Concrete Foundation
121	90	H10	S-11.0	Concrete Foundation
122	85	H8	S-09.0	Concrete Foundation
123	80	H8	S-09.0	Concrete Foundation
124	80	H8	S-09.0	Concrete Foundation
125	85	H7	S-08.0	Concrete Foundation
126	85	H7	S-08.0	Concrete Foundation
127	85	H8	S-09.0	Concrete Foundation
128	85	H8	S-09.0	Concrete Foundation
129	85	H8	S-09.0	Concrete Foundation
130	80	H6	S-07.4	Concrete Foundation

Structure #	Pole Height (ft.)	Wood Pole Equivalent	RUS Class	Embedment
131	80	H6	S-07.4	Concrete Foundation
132	75	ENG	ENG	Concrete Foundation
133	80	H6	S-07.4	Concrete Foundation
134	85	H10	S-11.0	Concrete Foundation
135	85	H7	S-08.0	Concrete Foundation
136	85	H8	S-09.0	Concrete Foundation
137	80	H6	S-07.4	Concrete Foundation
138	85	H10	S-11.0	Concrete Foundation
139	80	H6	S-07.4	Concrete Foundation
140	80	ENG	ENG	Concrete Foundation
141	80	ENG	ENG	Concrete Foundation
142	80	ENG	ENG	Concrete Foundation
143	85	ENG	ENG	Concrete Foundation
144	85	H10	S-11.0	Concrete Foundation
145	80	ENG	ENG	Concrete Foundation
146	75	H6	S-07.4	Concrete Foundation
147	75	ENG	ENG	Concrete Foundation
148	75	H6	S-07.4	Concrete Foundation
149	75	H6	S-07.4	Concrete Foundation
150	80	H6	S-07.4	Concrete Foundation
151	80	ENG	ENG	Concrete Foundation
152	85	H6	S-07.4	Concrete Foundation
153	85	ENG	ENG	Concrete Foundation
154	95	ENG	ENG	Concrete Foundation
155	85	H8	S-09.0	Concrete Foundation
156	85	H6	S-07.4	Concrete Foundation
157	80	H7	S-08.0	Concrete Foundation
158	75	H10	S-11.0	Concrete Foundation
159	75	H8	S-09.0	Concrete Foundation
160	70	H7	S-08.0	Concrete Foundation
161	70	H6	S-07.4	Concrete Foundation
162	70	H6	S-07.4	Concrete Foundation
163	70	H4	S-05.7	Concrete Foundation

Attachment B. Structure Drawings

[Balance of page left blank intentionally]

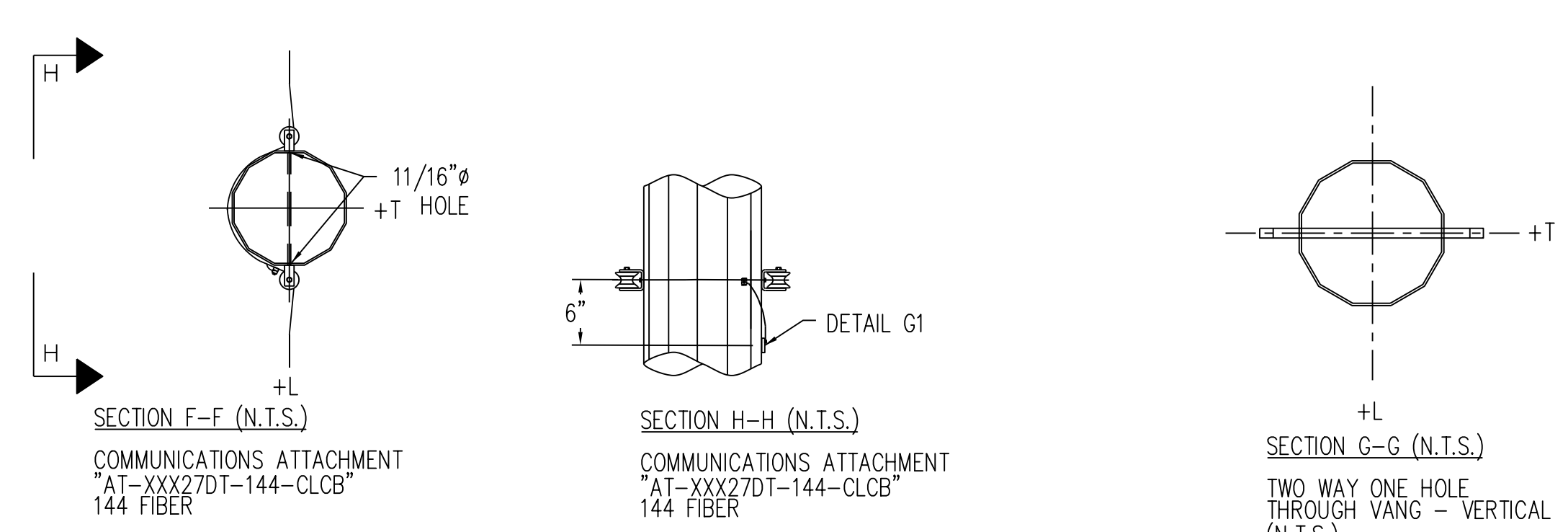
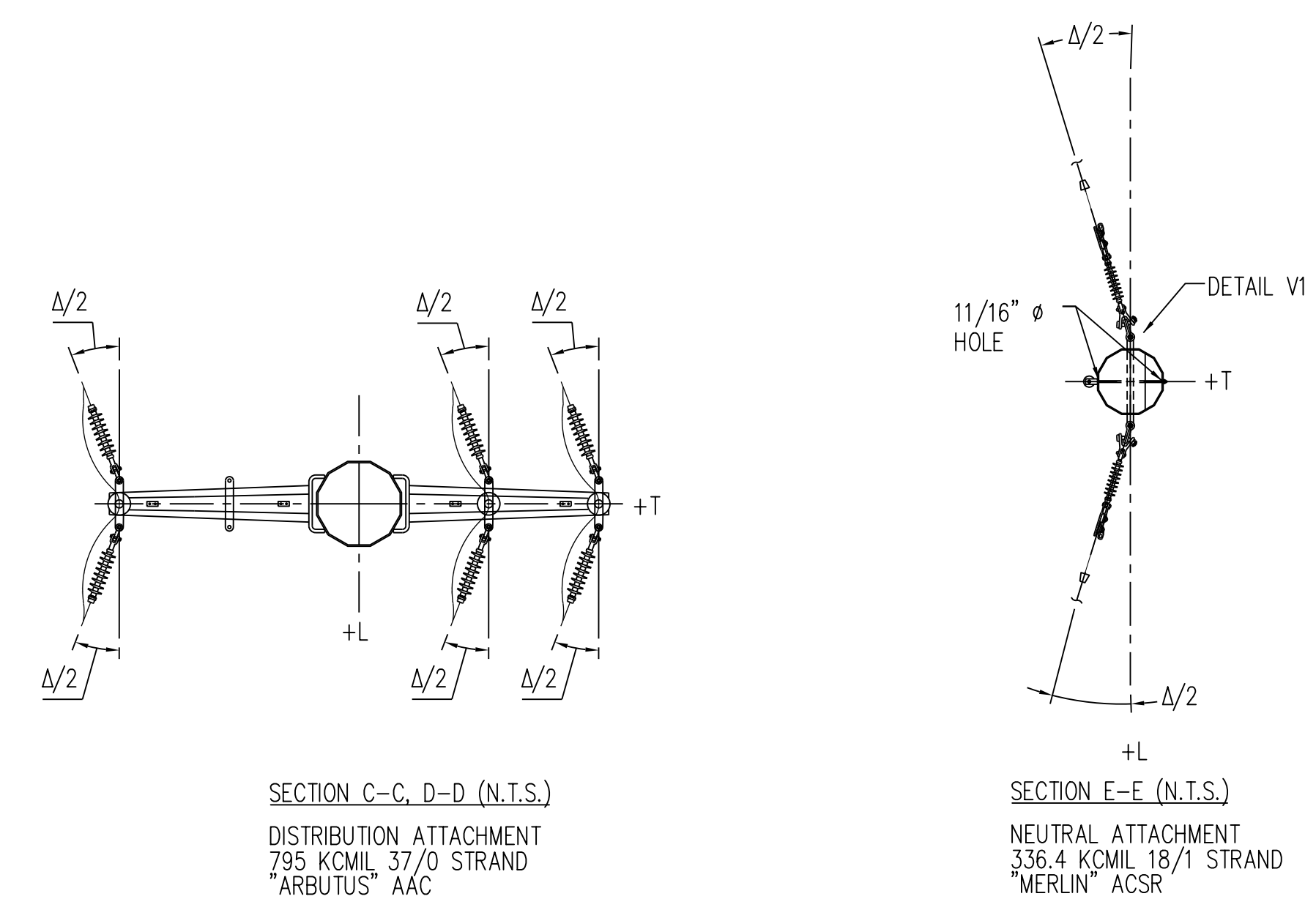
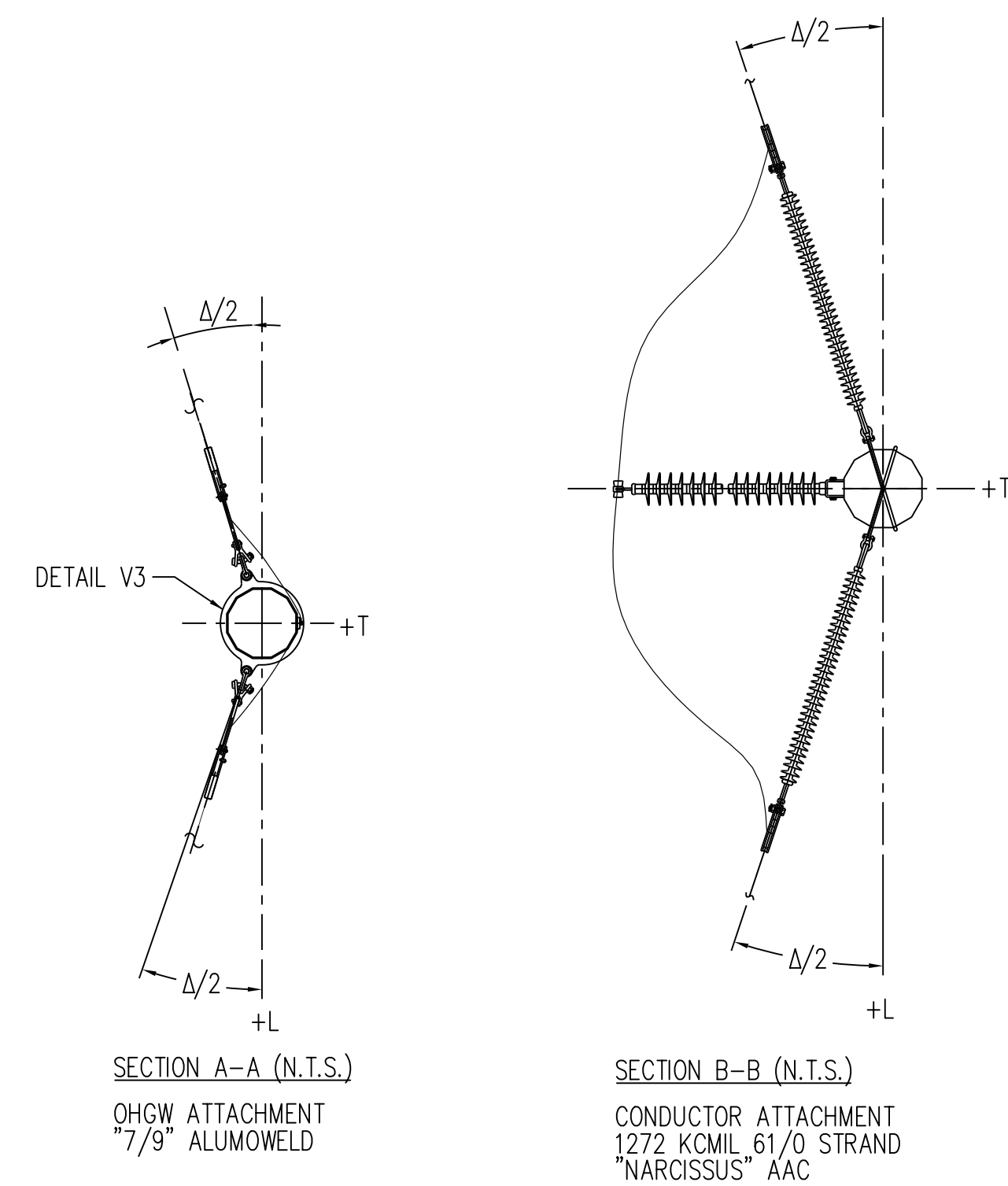
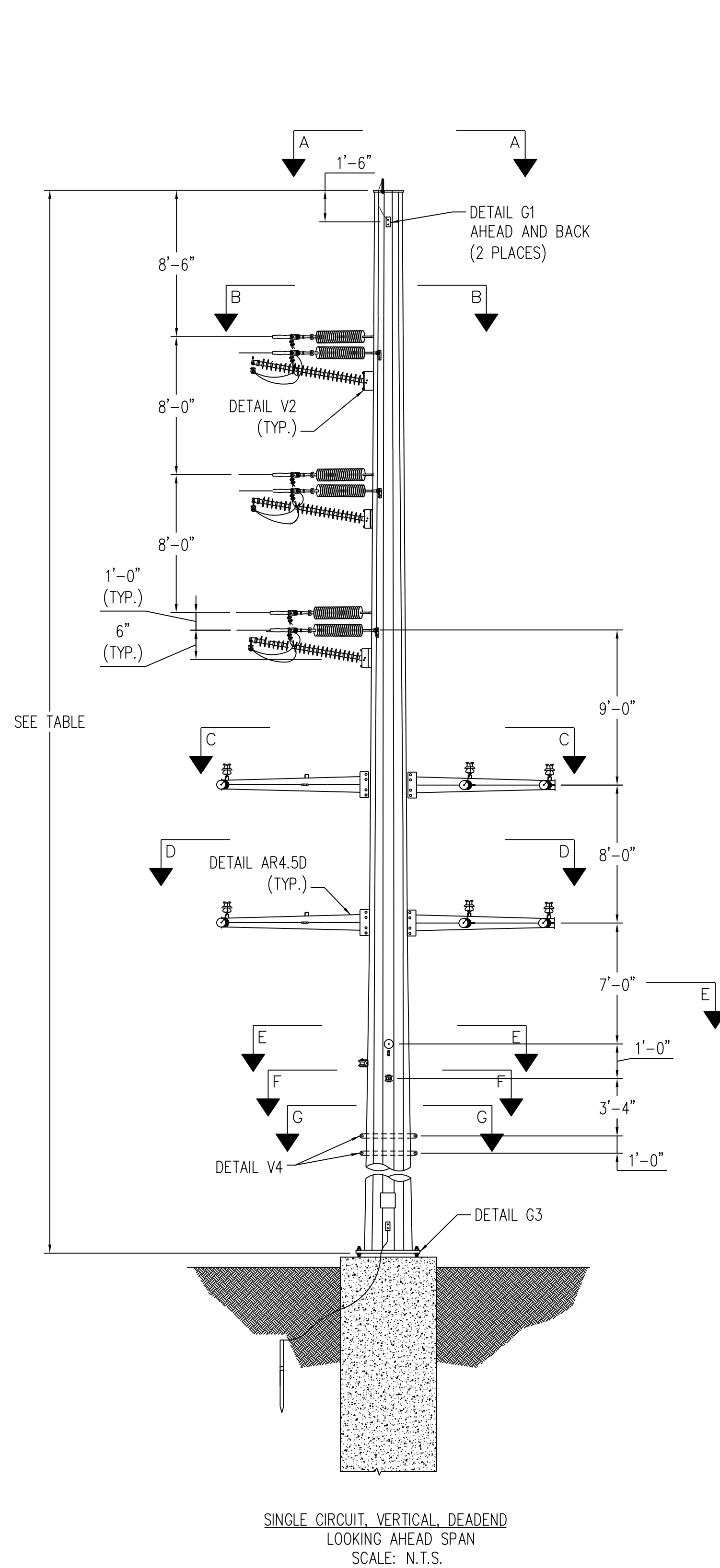

STR #	LENGTH (FT)	ANGLE Δ
1	80	-14
5	95	-28

LOAD	LOADING TABLE									
	CASE 1	CASE 2	CASE 3	CASE 4	CASE 5	CASE 6	CASE 7	CASE 10		
V1	1000	800	1300	700	600	900	600	1400		
T1	-3300	-5300	-2400	-1700	-2800	-1400	-800	-2500		
L1	100	400	800	4700	2900	4200	100	100		
V2	2800	1800	2800	1800	1200	1800	900	3600		
T2	-8300	-13400	-5700	-4500	-7100	-3200	-1400	-7300		
L2	1400	2000	1800	13100	8600	10400	700	400		
V3	1300	800	1500	1300	800	1500	400	5500		
T3	-5200	-6700	-3900	-2900	-4000	-2200	-900	-4400		
L3	1300	1500	1500	9100	6200	7600	600	1400		
V4	600	400	1000	600	400	800	200	700		
T4	-3700	-5300	-2800	-2000	-3500	-1600	-600	-3000		
L4	900	1000	1000	5800	3900	5100	300	300		
V5	300	200	800	200	200	500	200	200		
T5	-1100	-1300	-1100	-700	-800	-700	-300	-600		
L5	1600	1400	1600	1900	1800	2100	700	1100		
V6	500	300	1000	300	200	600	200	300		
T6	-1100	-1700	-1300	-600	-1000	-800	-200	-400		
L6	1600	2000	2100	1600	2200	2300	400	700		
W(PSF)	10	36.9	4.1	10	36.9	4.1	0	3		

ALL LOADS ARE IN LBS, ARE ULTIMATE, AND INCLUDE ALL OVERLOAD FACTORS. "W" REPRESENTS WIND PRESSURE (psf) TO BE APPLIED TO STRUCTURE.

LOAD CASES

- CASE 1 NESM MEDIUM: 15°, .25" ICE, 4 PSF WIND
OLF: L=1.65, T=2.50, V=1.50
- CASE 2 NESM HIGH WIND: 60°, 0" ICE, 120 MPH WIND
OLF: L=1.00, T=1.00, V=1.00
- CASE 3 NESM ICE WITH WIND: 15°, 1" ICE, 40 MPH WIND
OLF: L=1.00, T=1.00, V=1.00
- CASE 4 NESM MEDIUM DEADEND: 15°, .25" ICE, 4 PSF WIND
OLF: L=1.65, T=2.50, V=1.50
- CASE 5 NESM HIGH DEADEND: 60°, 0" ICE, 120 MPH WIND
OLF: L=1.00, T=1.00, V=1.00
- CASE 6 NESM ICE WITH DEADEND: 15°, 1" ICE, 40 MPH WIND
OLF: L=1.00, T=1.00, V=1.00
- CASE 7 DEFLECTION: 60 DEGREES, NO ICE, NO WIND, FINAL
OLF: L=1.00, T=1.00, V=1.00
- CASE 10 STRINGING: -20°, 0" ICE, 2 PSF WIND
OLF: L=1.50, T=1.50, V=1.50

WIRE DATA

OHGW: "7#9" ALUMOWELD
 115kV: 1272 KCMIL 61/0 STRAND "NARCISSUS" AAC
 12.47kV: 795 KCMIL 37/0 STRAND "ARBUTUS" AAC
 DISTRIBUTION NEUTRAL: 336.4 KCMIL 18/1 STRAND "MERLIN" ACSR
 ADSS: "AT-XXX27DT-144-CLCB" 144 FIBER

NOTES:

- ALL STATED LOADS ARE ULTIMATE VALUES AND INCLUDE OVERLOAD FACTORS AND INSULATOR WEIGHT.
- STRUCTURE AND ATTACHMENTS SHALL BE DESIGNED FOR THE SIMULTANEOUS APPLICATION OF DEAD LOAD, WIND ON THE STRUCTURE, AND WIRE LOADS FOR EACH LOADING CASE.
- STRUCTURE SHALL BE DESIGNED SELF SUPPORTING, GUYS ARE NOT PERMITTED. STRUCTURE SHALL MEET ALL TECHNICAL REQUIREMENTS OF THE STEEL POLE SPECIFICATIONS.
- WIND PRESSURES SHOWN ON LOAD WORKSHEET ARE BASED ON A SHAPE FACTOR OF 1.0.
- FABRICATOR MAY PROPOSE STRUCTURAL DETAILS DIFFERENT THAN THOSE SHOWN TO SIMPLIFY FABRICATION. VARIATIONS SHALL BE SUBMITTED TO ENGINEER IN WRITING.
- MINIMUM VANG PLATE THICKNESS = 1/2".
- WIND SHALL BE APPLIED IN THE DIRECTION WHICH RESULTS IN THE MOST SEVERE EFFECT.
- THE DEFLECTION AT THE POLE TOP SHALL BE LIMITED TO 1.5% OF THE POLE HEIGHT UNDER THE DEFLECTION CASE. POLES MAY BE CAMBERED TO FALL WITHIN THE DESIGN LIMIT.
- MAXIMUM DEFLECTION AT TOP OF THE STRUCTURE SHALL BE LIMITED TO 10% OF STRUCTURE HEIGHT UNDER ALL LOAD CASES WITH THE EXCEPTION TO THE 60°F NO WIND LOAD CASE.
- POLE DESIGN AND FABRICATION SHALL INCLUDE PROVISIONS FOR A SLIP JOINT TO LIMIT LOWEST POLE SEGMENT EXTENSION ABOVE GRADE TO 12"-0" MAXIMUM.
- ALL STRUCTURES SHALL BE GALVANIZED STEEL.
- ORIENT SINGLE SIDED VANGS FOR HARDWARE SHOWN ON DRAWINGS.
- MANUFACTURER SHALL APPLY POINT LOADS NECESSARY TO CREATE THE MOST SEVERE EFFECTS ON ALL MEMBERS INCLUDING ARMS, POLES, BASE PLATES, ETC.

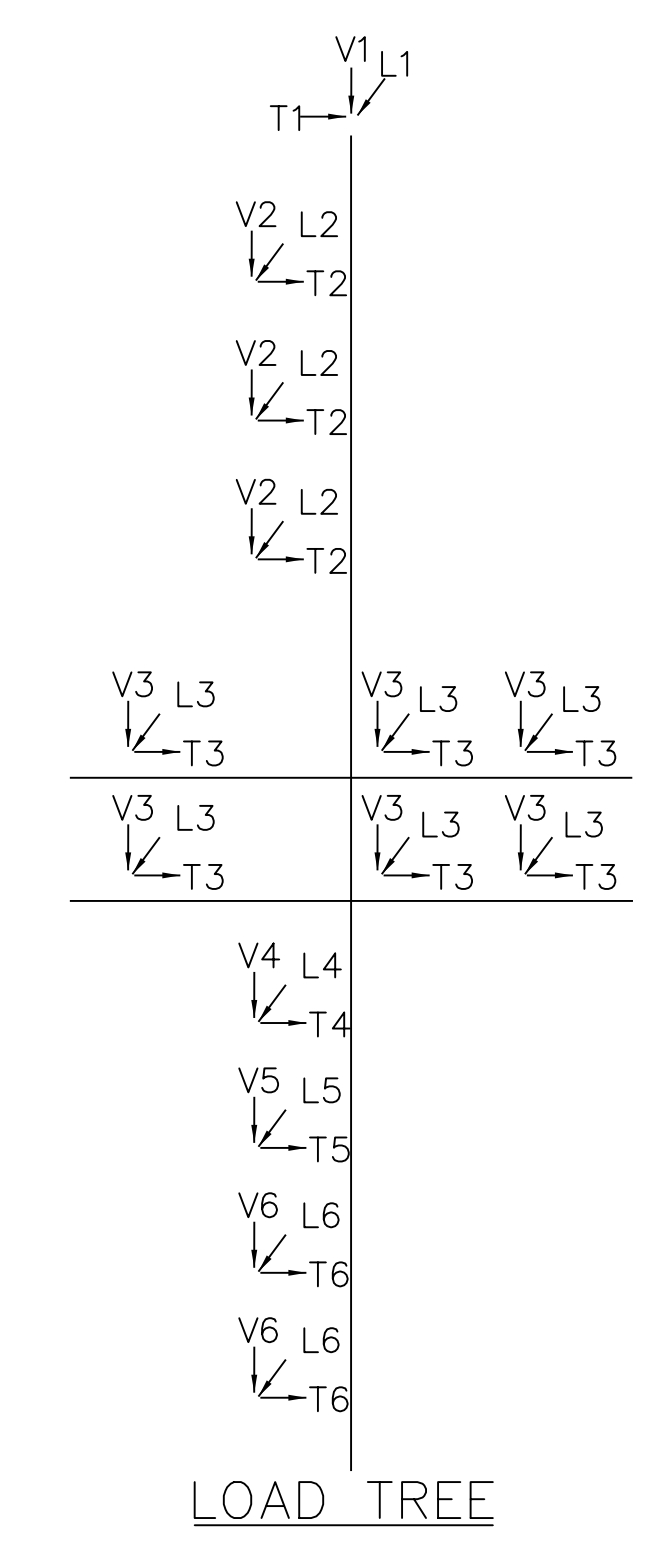

NO.	REVISIONS
A	MT. PLEASANT TO SUGG T-LINE ISSUED FOR BID ENGINEERS: S.E DATE: 12/03/21

CONSTRUCTION NOTE:
 REMOVE OLD WIRE LABELS WITH ORANGE TEXT,
 INSTALL NEW WIRE LABELS WITH GREEN TEXT

ISSUED FOR BID

GREENVILLE UTILITIES
 Greenville, North Carolina

115kV TRANSMISSION LINE
 MT. PLEASANT SUB TO SUGG
 LOAD AND DESIGN
 DEADEND 0'-30" WITH UNDERBUILD

DWIND, CHAMBLISS DATE 12/03/21 DWG. NO.
 CKD, R. DILLABOUGH APPD. S. ECKMAN DE-30L_2Darm_1-CD
 SCALE: NONE

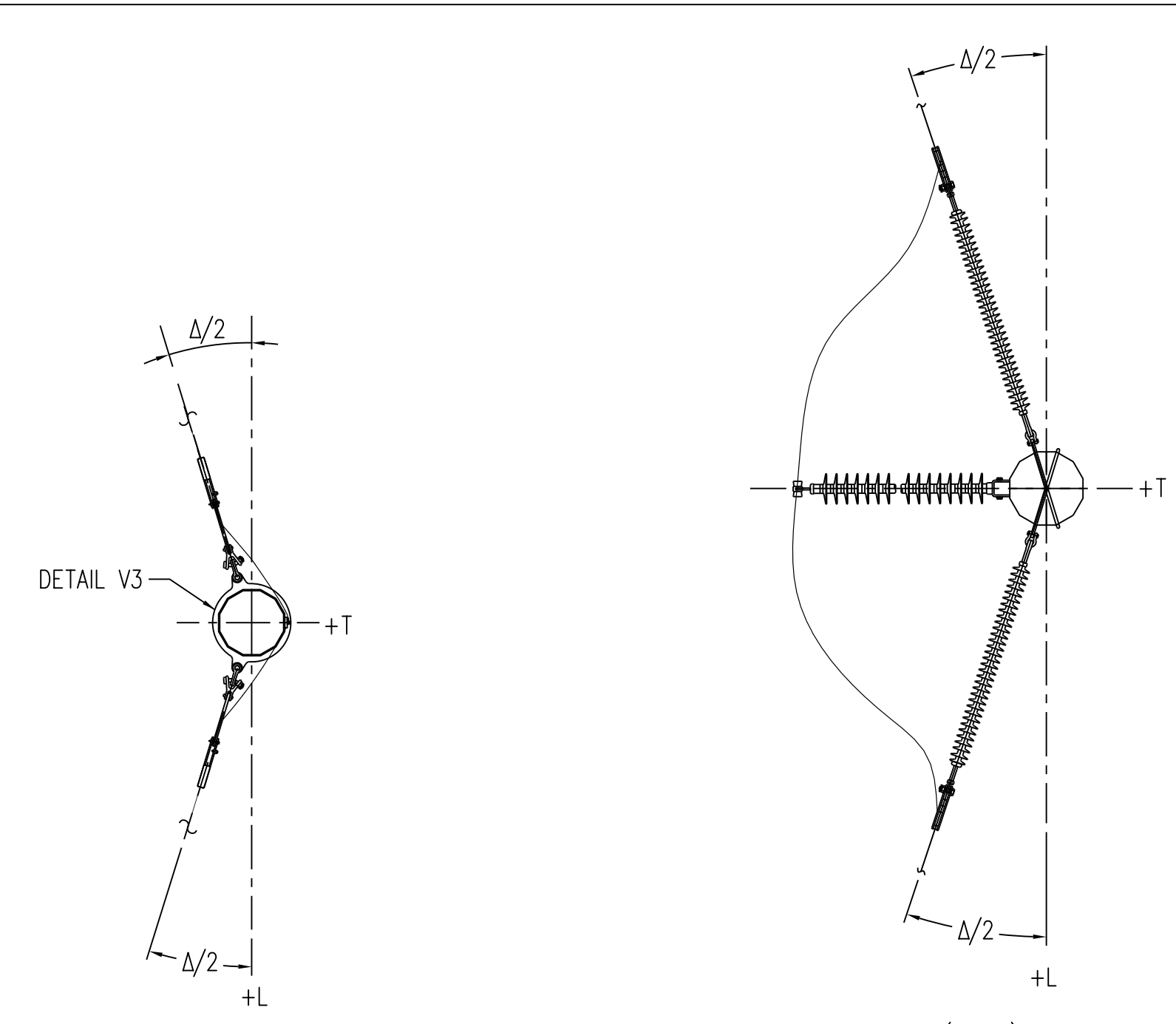
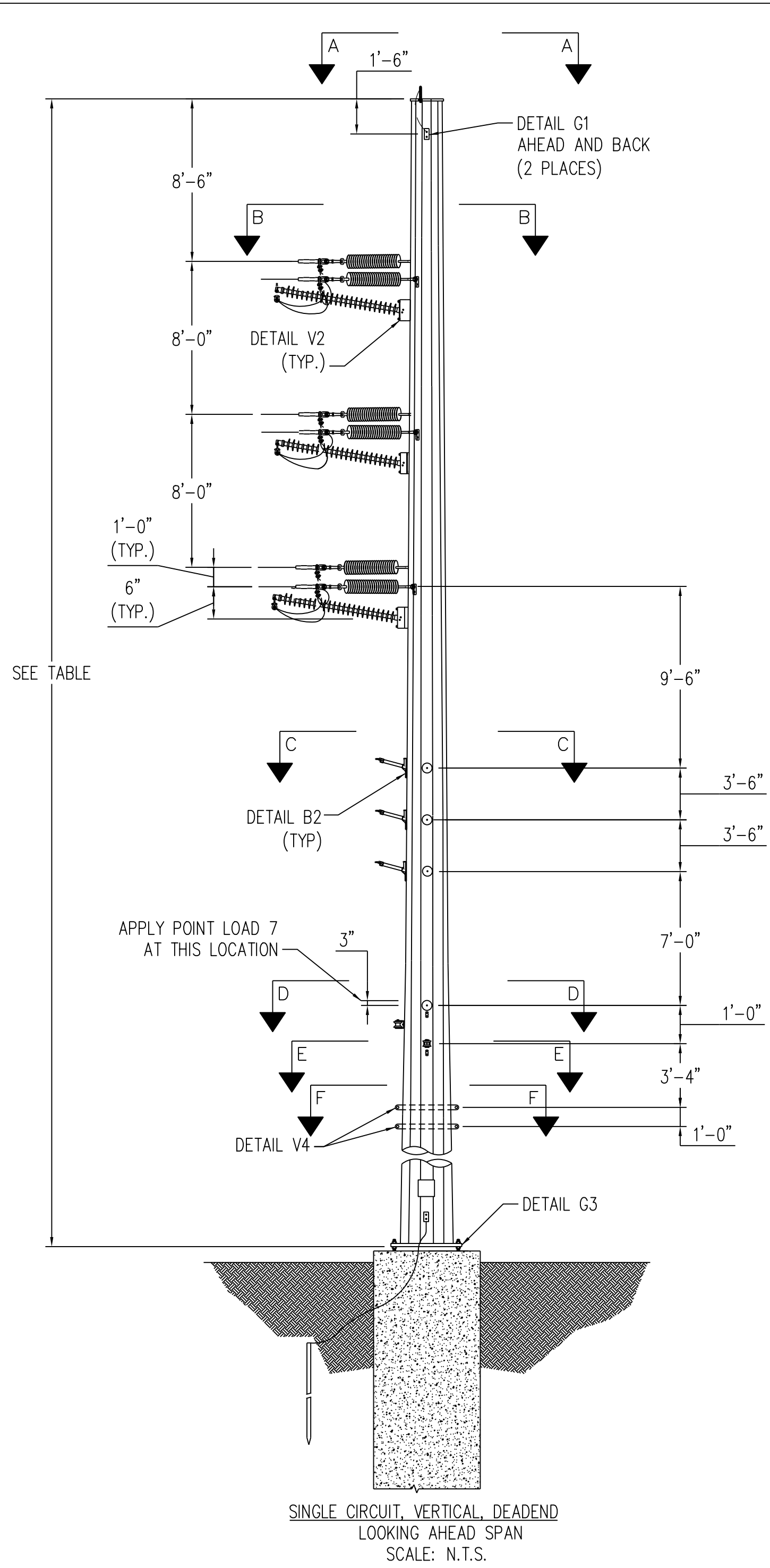

STR #	LENGTH (FT)	ANGLE Δ
151	80	-19
154	95	-21

LOAD	LOADING TABLE									
	CASE 1	CASE 2	CASE 3	CASE 4	CASE 5	CASE 6	CASE 7	CASE 10		
V1	400	300	800	200	200	500	200	400		
T1	-2400	-4900	-1900	-1400	-2600	-1100	-400	-1500		
L1	-2200	-1200	-1300	-4700	-2900	-4100	-1000	-1900		
V2	1400	900	1800	700	500	1000	600	1400		
T2	-6900	-12700	-4600	-3600	-6500	-2500	-1000	-5800		
L2	-900	-1100	-1000	-12900	-8300	-10200	-400	-400		
V3	600	400	1100	300	200	600	200	3100		
T3	-3100	-5200	-2300	-1600	-2700	-1200	-400	-2200		
L3	-500	-500	-600	-5700	-3900	-5000	-200	-900		
V4	300	200	800	200	100	400	100	300		
T4	-2000	-4200	-1500	-1100	-2100	-800	-300	-1100		
L4	-300	-300	-300	-2800	-1900	-2800	-100	-100		
V5	400	200	900	200	100	500	200	200		
T5	-1000	-1200	-1000	-500	-700	-500	-300	-500		
L5	-300	-300	-400	-1800	-1800	-2000	-100	-100		
V6	500	300	1100	300	200	600	200	300		
T6	-1000	-1600	-1100	-500	-800	-600	-200	-300		
L6	-100	-200	-300	-1600	-2100	-2300	-100	-200		
V7	2000	900	4100	1600	800	3400	900	1500		
T7	-1900	-2500	-2500	-1500	-2000	-2000	-300	-800		
L7	-600	-800	-1000	-1000	-1300	-1600	-200	-300		
W(P5F)	10	36.9	4.1	10	36.9	4.1	0	3		

ALL LOADS ARE IN LBS, ARE ULTIMATE, AND INCLUDE ALL OVERLOAD FACTORS. "W" REPRESENTS WIND PRESSURE (psf) TO BE APPLIED TO STRUCTURE.

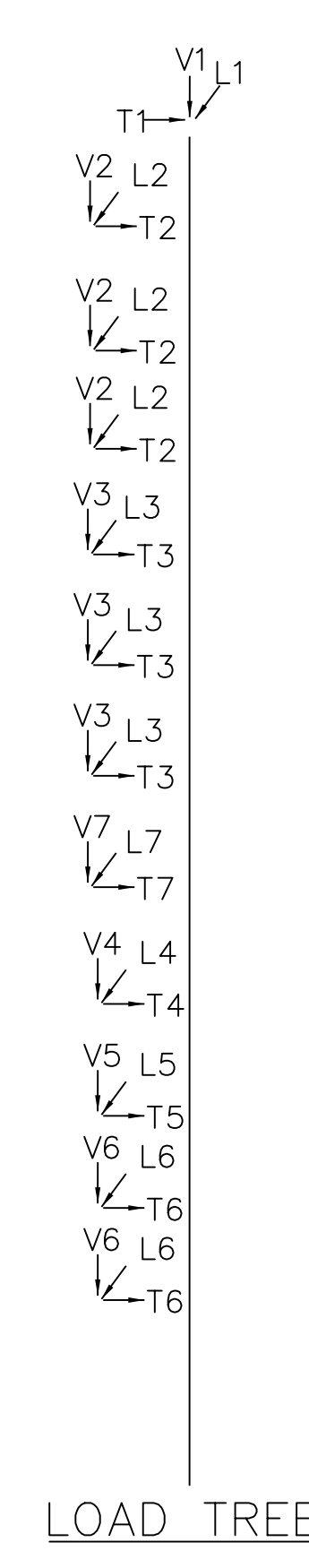
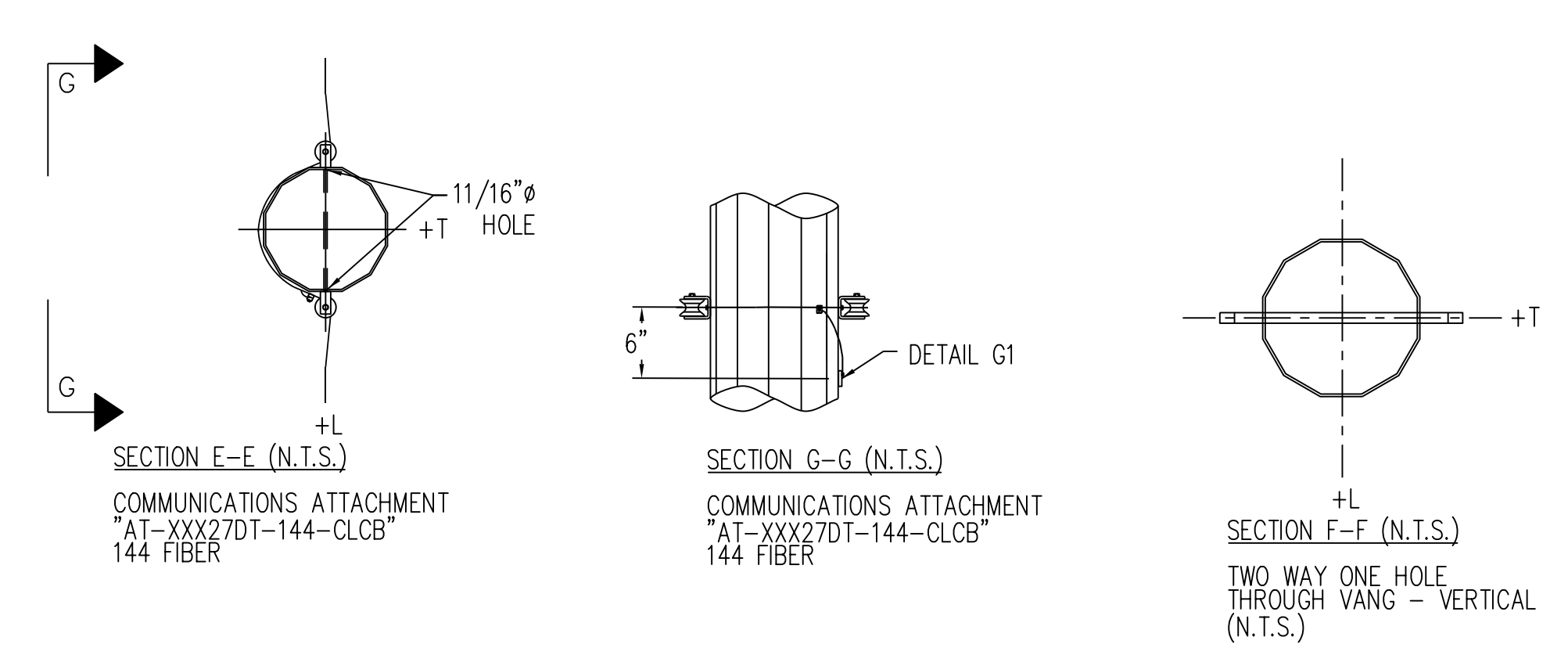
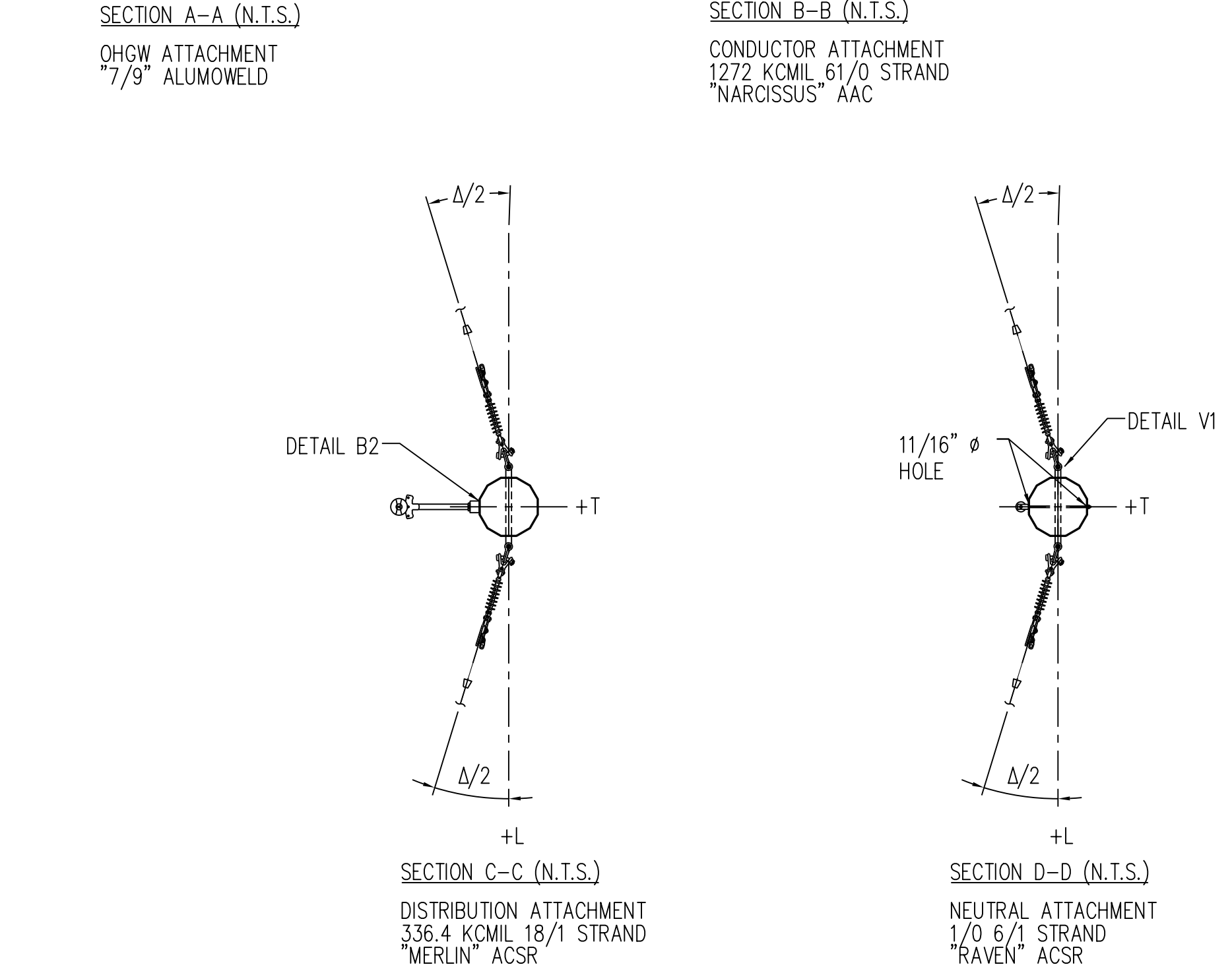

LOAD CASES

- CASE 1 NESIC MEDIUM: 15°, .25" ICE, 4 PSF WIND
OLF: L=1.65, T=2.50, V=1.50
- CASE 2 NESIC HIGH WIND: 60°, 0" ICE, 120 MPH WIND
OLF: L=1.00, T=1.00, V=1.00
- CASE 3 NESIC ICE WITH WIND: 15°, 1" ICE, 40 MPH WIND
OLF: L=1.00, T=1.00, V=1.00
- CASE 4 NESIC MEDIUM DEADEND: 15°, .25" ICE, 4 PSF WIND
OLF: L=1.65, T=2.50, V=1.50
- CASE 5 NESIC HIGH WIND DEADEND: 60°, 0" ICE, 120 MPH WIND
OLF: L=1.00, T=1.00, V=1.00
- CASE 6 NESIC ICE WITH WIND DEADEND: 15°, 1" ICE, 40 MPH WIND
OLF: L=1.00, T=1.00, V=1.00
- CASE 7 DEFLECTION: 60 DEGREES, NO ICE, NO WIND, FINAL
OLF: L=1.00, T=1.00, V=1.00
- CASE 10 STRINGING: -20°, 0" ICE, 2 PSF WIND
OLF: L=1.50, T=1.50, V=1.50

WIRE DATA

OHGW: "7#9" ALUMOWELD
 115kV: 1272 KCMIL 61/0 STRAND "NARCISSUS" AAC
 12.47kV: 336.4 KCMIL 18/1 STRAND "MERLIN" ACSR
 DISTRIBUTION NEUTRAL: 1/0 6/1 STRAND "RAVEN" ACSR
 ADSS: "AT-XXX27DT-144-CLCB" 144 FIBER

NOTES:

- ALL STATED LOADS ARE ULTIMATE VALUES AND INCLUDE OVERLOAD FACTORS AND INSULATOR WEIGHT.
- STRUCTURE AND ATTACHMENTS SHALL BE DESIGNED FOR THE SIMULTANEOUS APPLICATION OF DEAD LOAD, WIND ON THE STRUCTURE, AND WIRE LOADS FOR EACH LOADING CASE.
- STRUCTURE SHALL BE DESIGNED SELF SUPPORTING, GUYS ARE NOT PERMITTED. STRUCTURE SHALL MEET ALL TECHNICAL REQUIREMENTS OF THE STEEL POLE SPECIFICATIONS.
- WIND PRESSURES SHOWN ON LOAD WORKSHEET ARE BASED ON A SHAPE FACTOR OF 1.0.
- FABRICATOR MAY PROPOSE STRUCTURAL DETAILS DIFFERENT THAN THOSE SHOWN TO SIMPLIFY FABRICATION. VARIATIONS SHALL BE SUBMITTED TO ENGINEER IN WRITING.
- MINIMUM VANG PLATE THICKNESS = 1/2".
- WIND SHALL BE APPLIED IN THE DIRECTION WHICH RESULTS IN THE MOST SEVERE EFFECT.
- THE DEFLECTION AT THE POLE TOP SHALL BE LIMITED TO 1.5% OF THE POLE HEIGHT UNDER THE DEFLECTION CASE. POLES MAY BE CAMBERED TO FALL WITHIN THE DESIGN LIMIT.
- MAXIMUM DEFLECTION AT TOP OF THE STRUCTURE SHALL BE LIMITED TO 10% OF STRUCTURE HEIGHT UNDER ALL LOAD CASES WITH THE EXCEPTION TO THE 60°F NO WIND LOAD CASE.
- POLE DESIGN AND FABRICATION SHALL INCLUDE PROVISIONS FOR A SLIP JOINT TO LIMIT LOWEST POLE SEGMENT EXTENSION ABOVE GRADE TO 12'-0" MAXIMUM.
- ALL STRUCTURES SHALL BE GALVANIZED STEEL.
- ORIENT SINGLE SIDED VANGS FOR HARDWARE SHOWN ON DRAWINGS.
- MANUFACTURER SHALL APPLY POINT LOADS NECESSARY TO CREATE THE MOST SEVERE EFFECTS ON ALL MEMBERS INCLUDING ARMS, POLES, BASE PLATES, ETC.

NO.	A
REVISIONS	MT. PLEASANT TO SUGG T-LINE ISSUED FOR BID ENGINEERS: S.E DATE: 12/03/21

CONSTRUCTION NOTE:
 REMOVE OLD WIRE LABELS WITH ORANGE TEXT,
 INSTALL NEW WIRE LABELS WITH GREEN TEXT

ISSUED FOR BID

GREENVILLE UTILITIES
 Greenville, North Carolina

115kV TRANSMISSION LINE
 MT. PLEASANT SUB TO SUGG
 LOAD AND DESIGN
 DEADEND 0'-30" WITH UNDERBUILD

DWIND. CHAMBLISS DATE 12/03/21 DWG. NO.
 CKD. R. DILLABOUGH APPD. S. ECKMAN DE-30L_Vert_1-CD
 SCALE: NONE

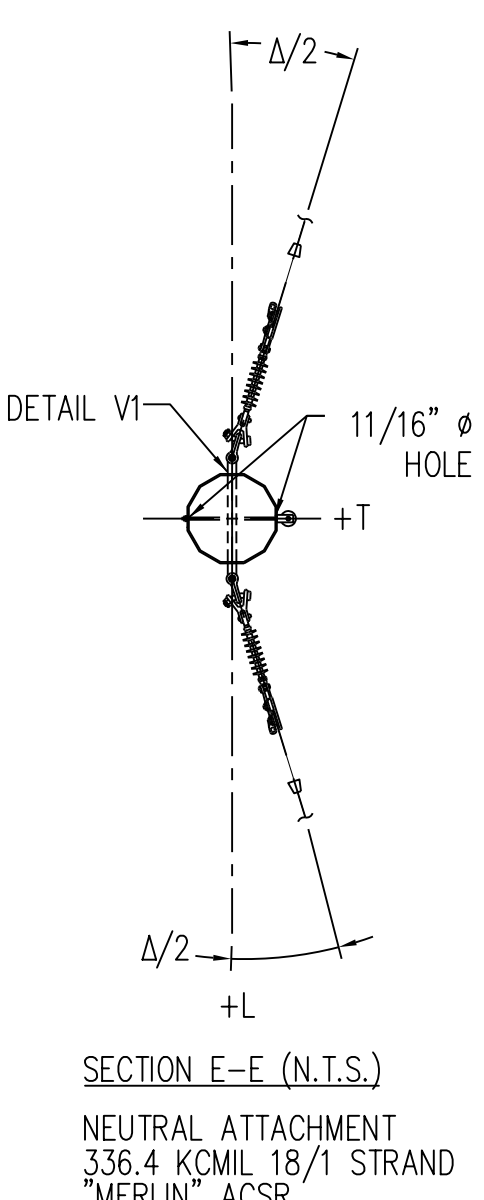
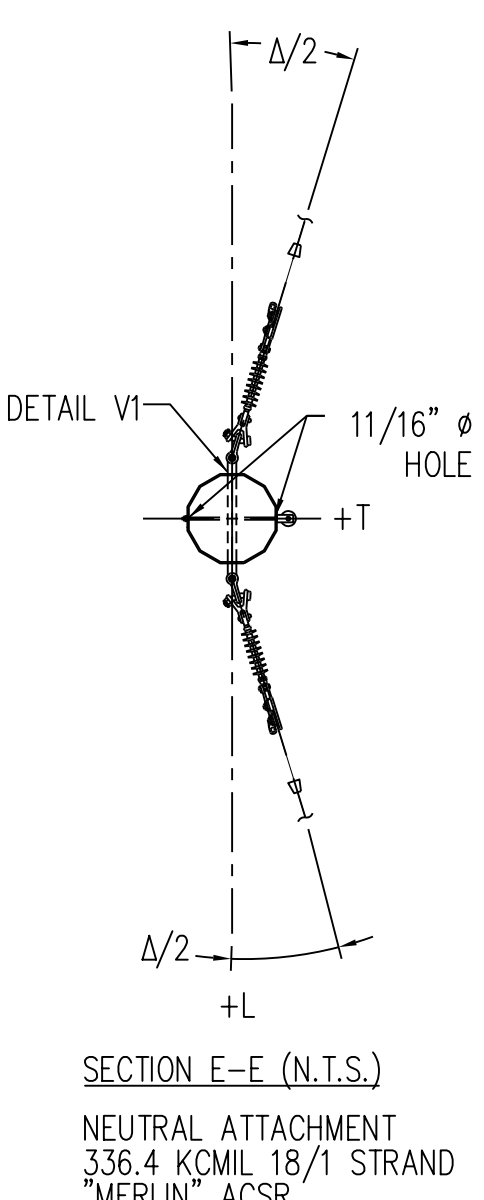
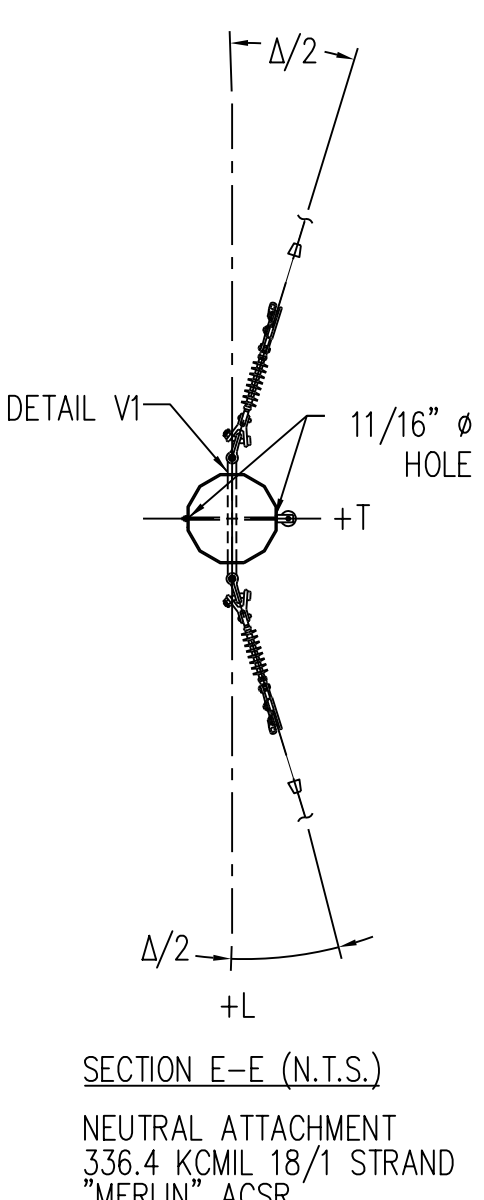
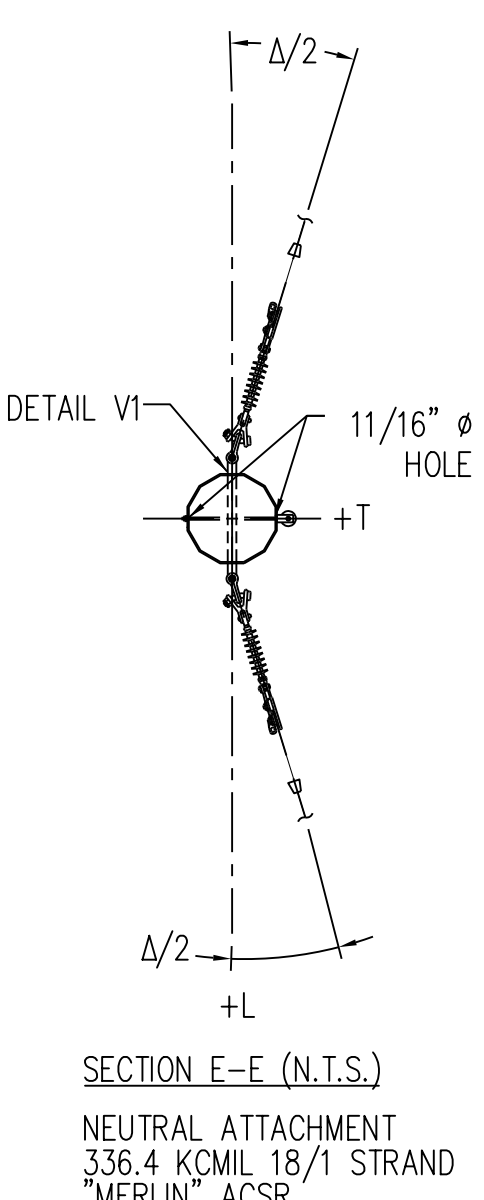
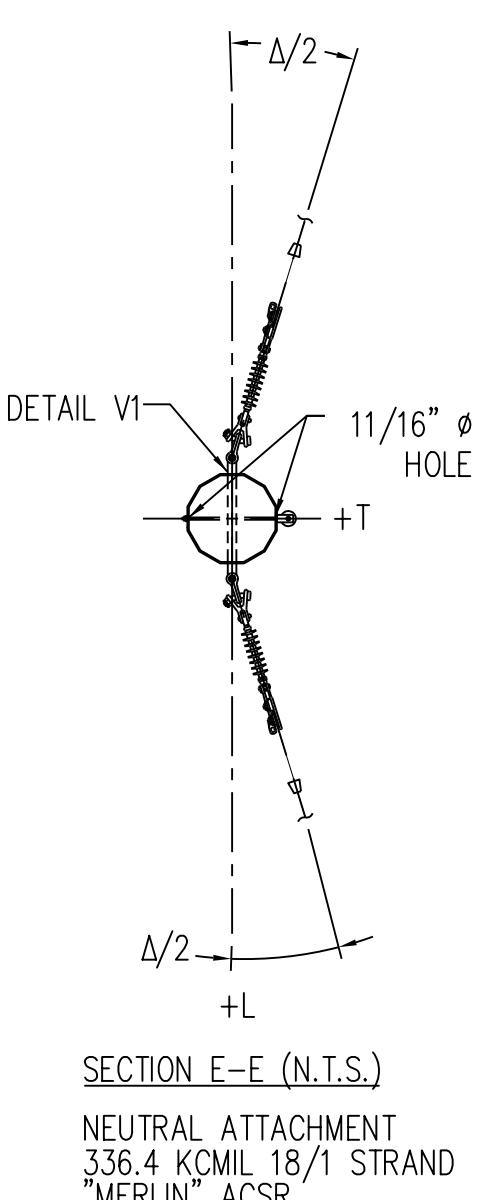
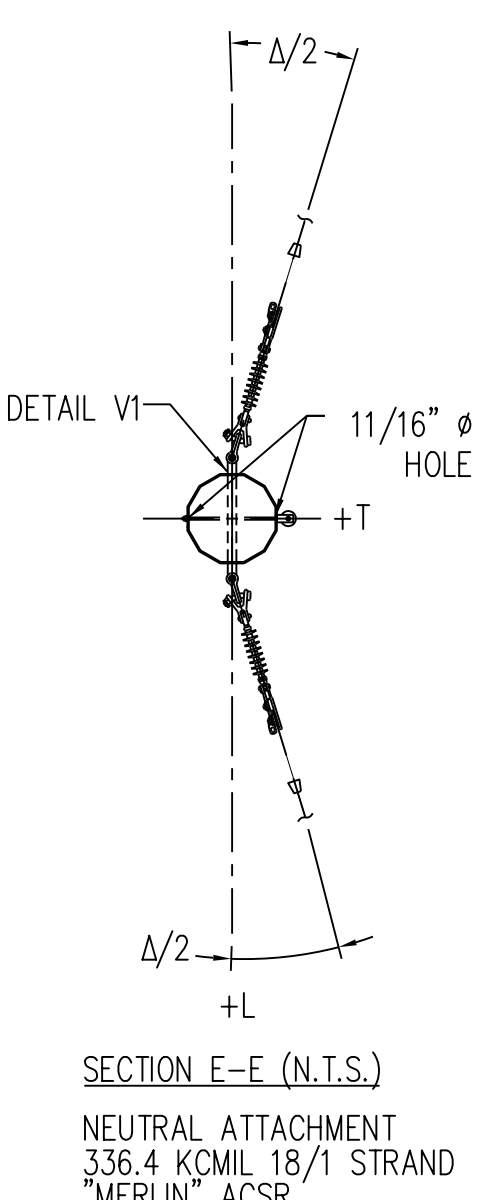
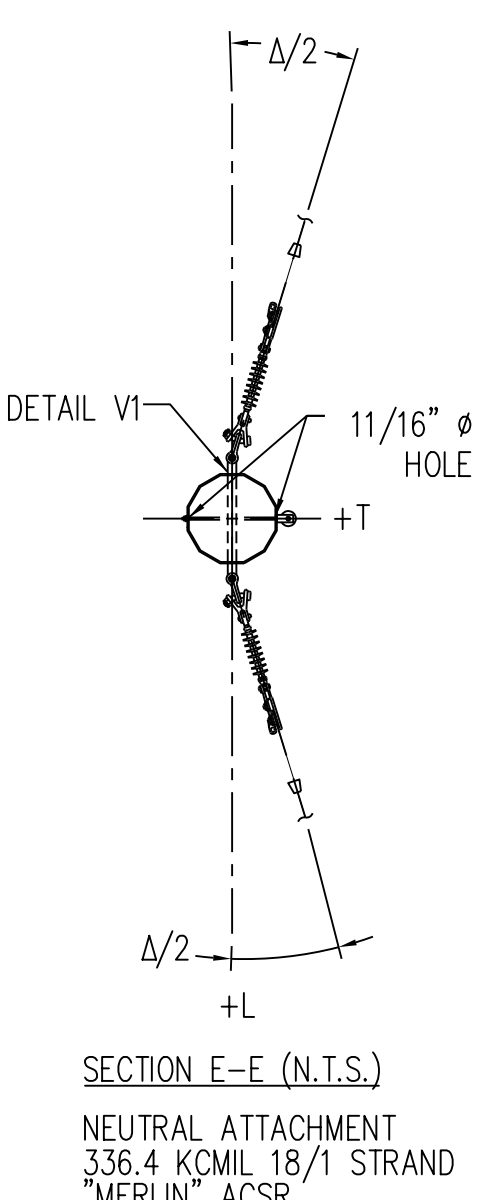
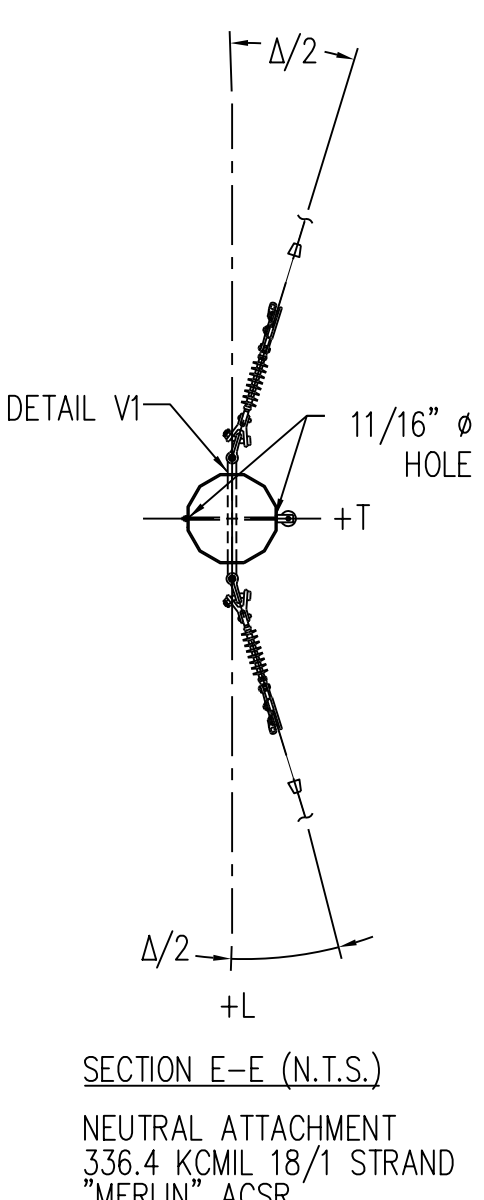
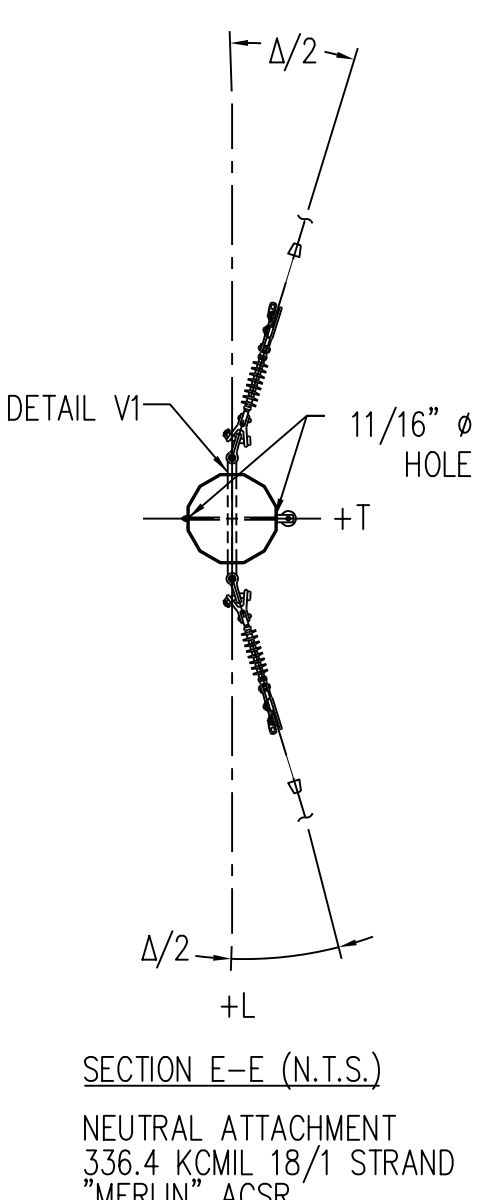
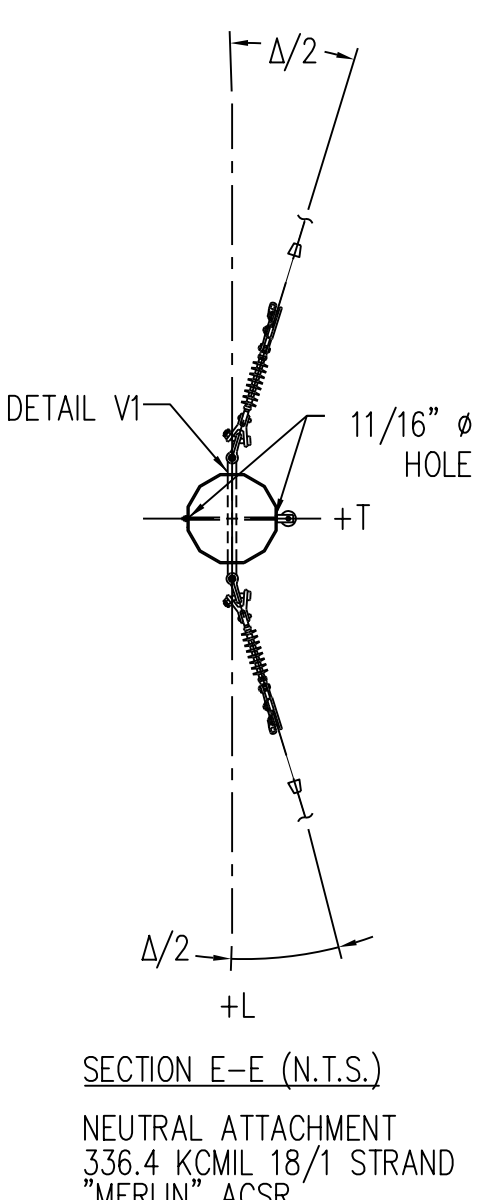
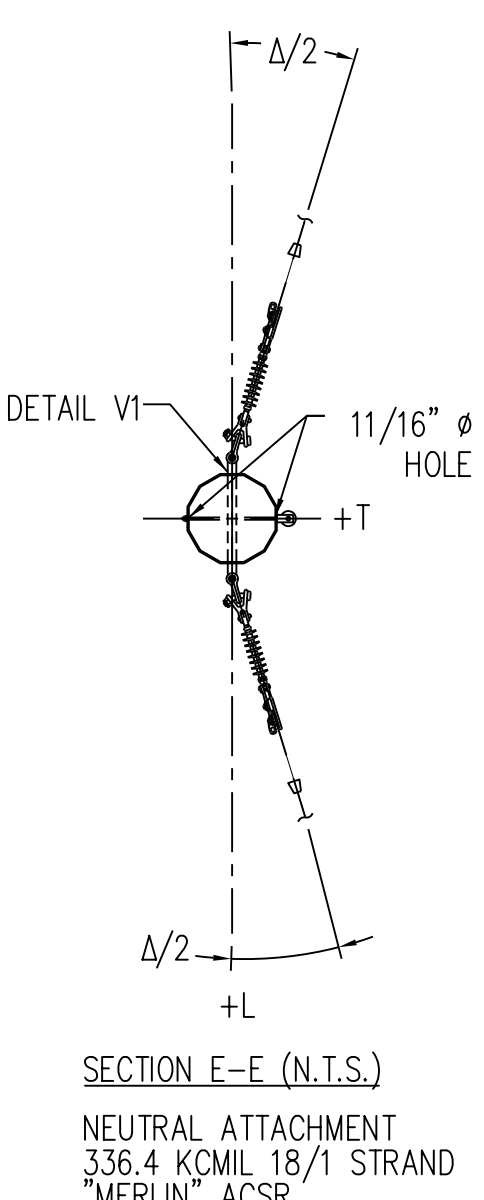
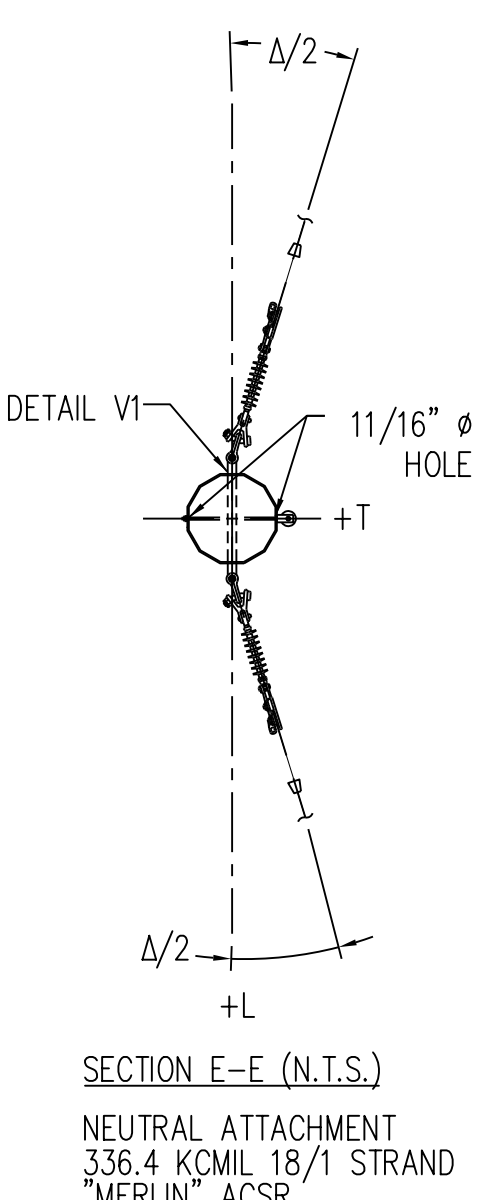
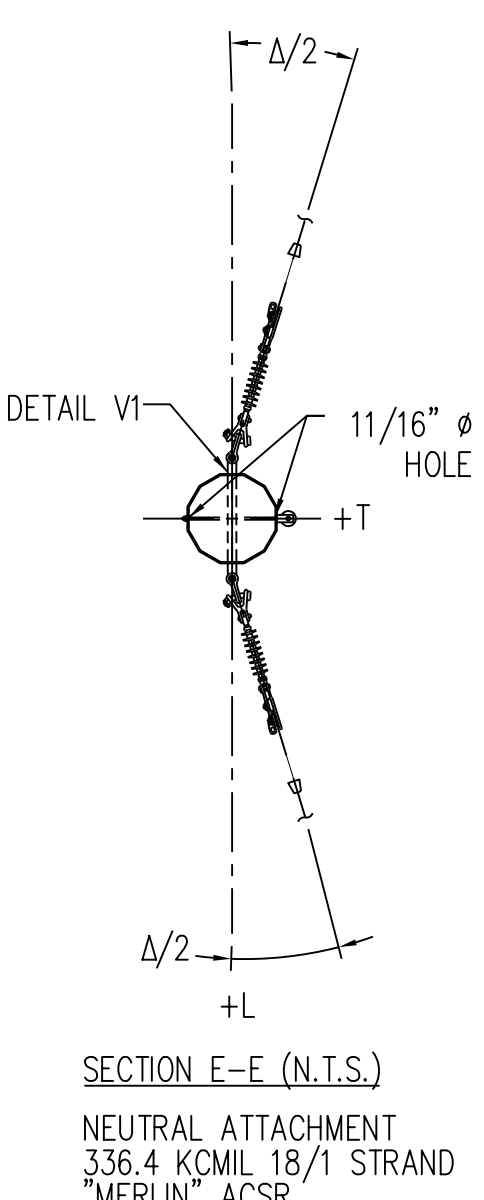
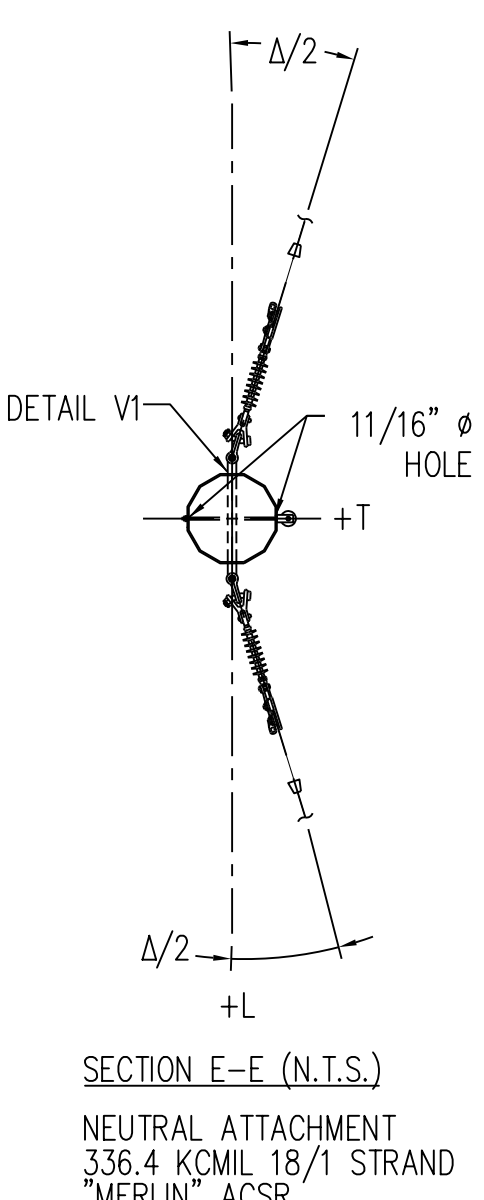
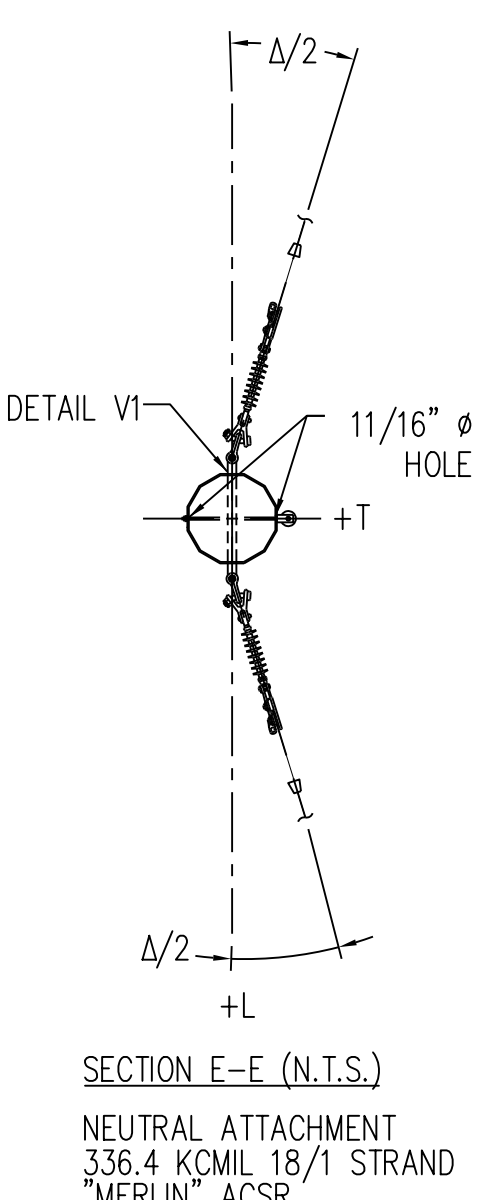
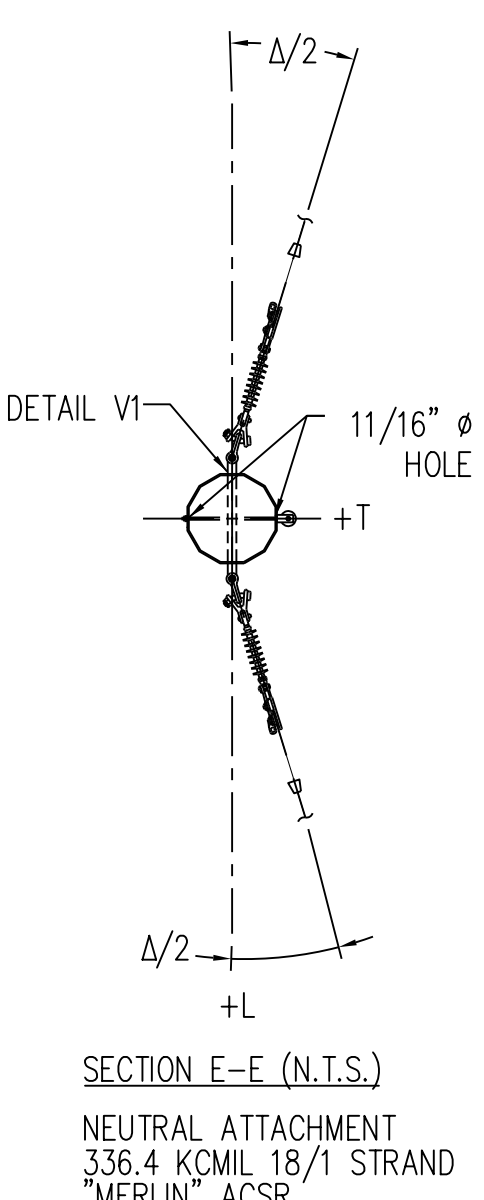
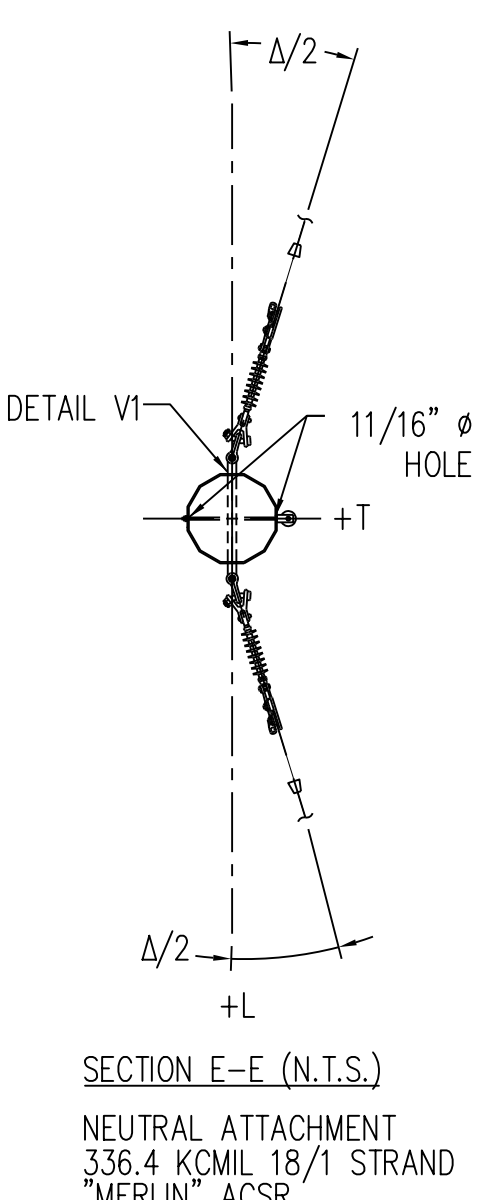
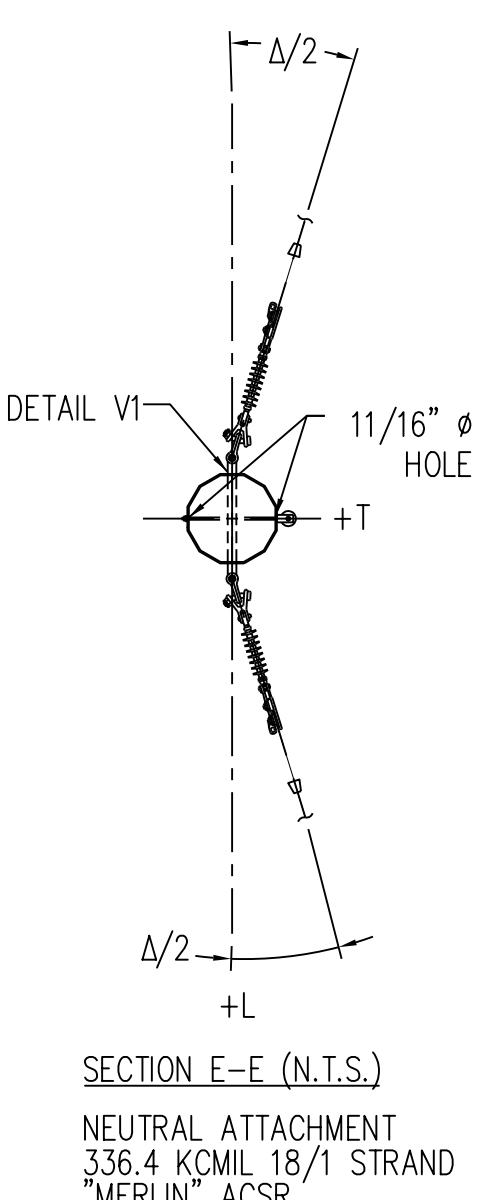
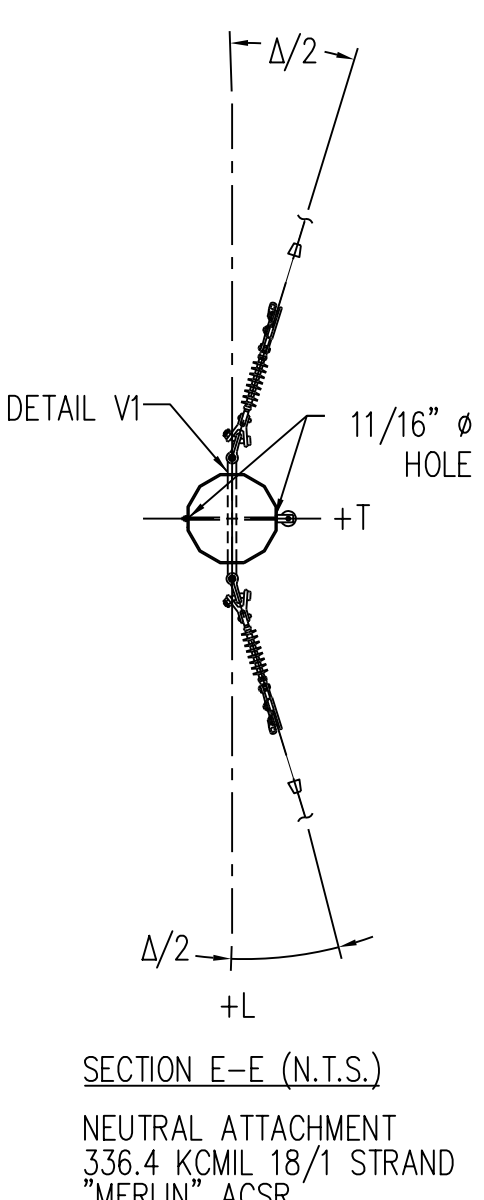
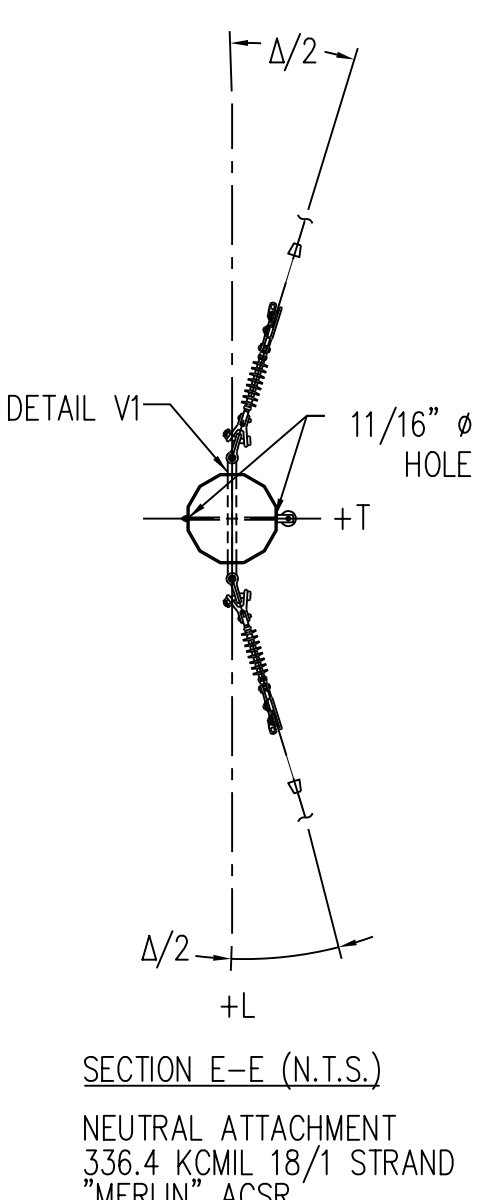
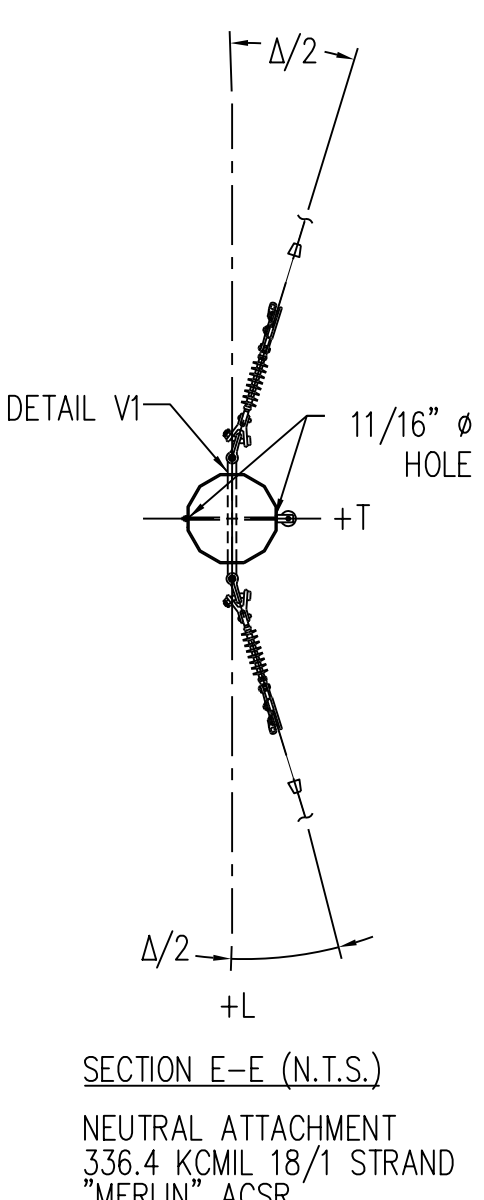
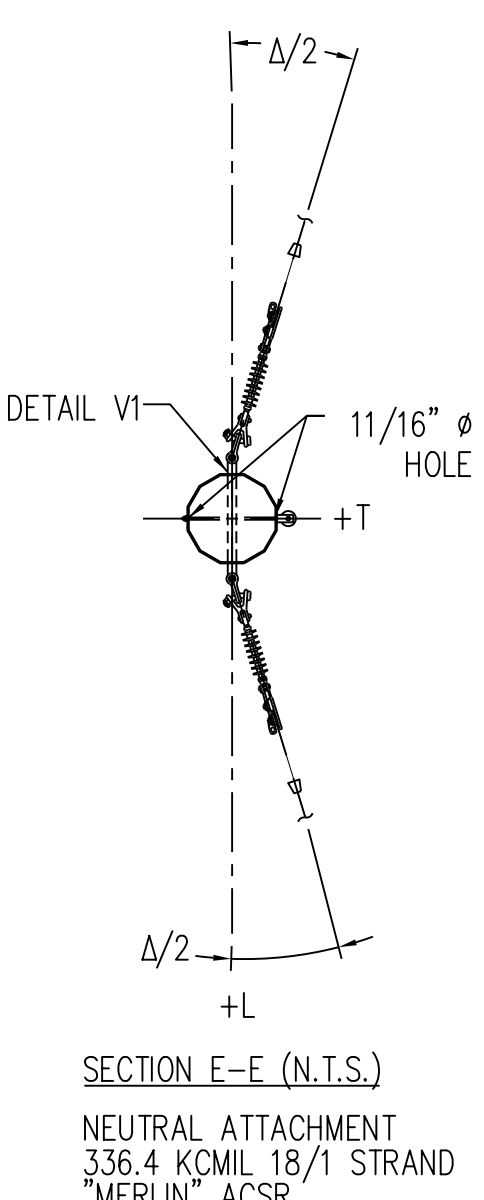
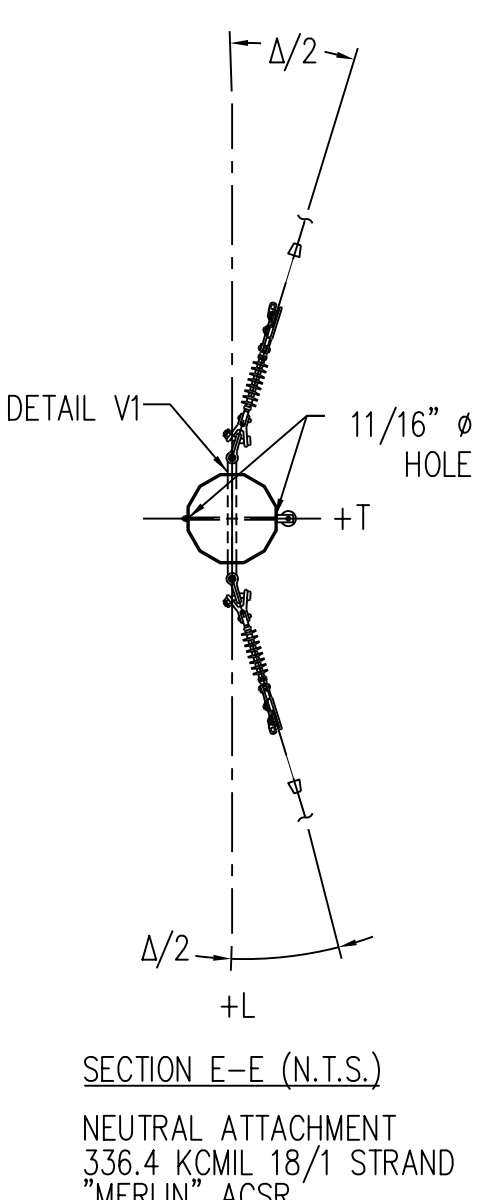
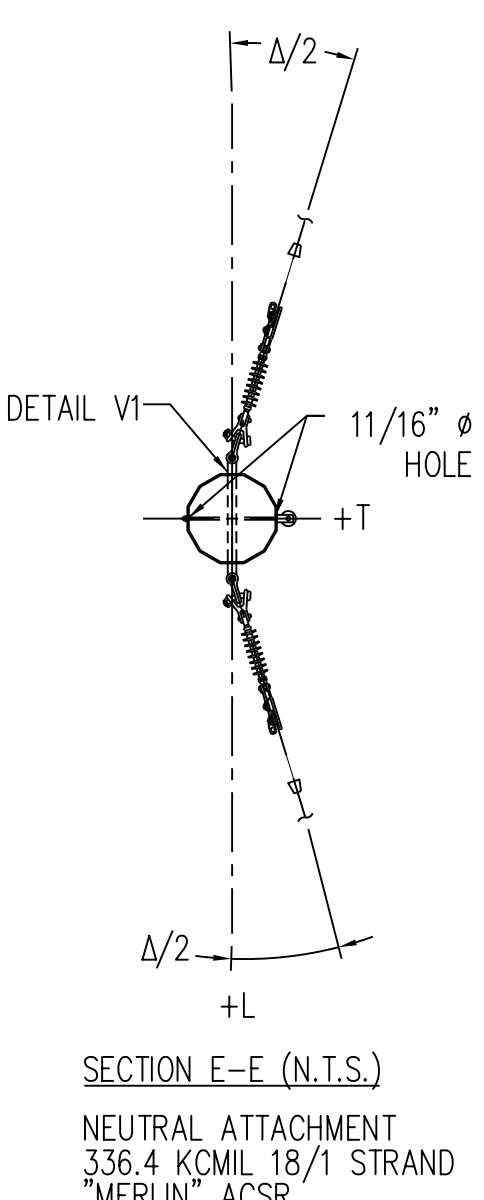
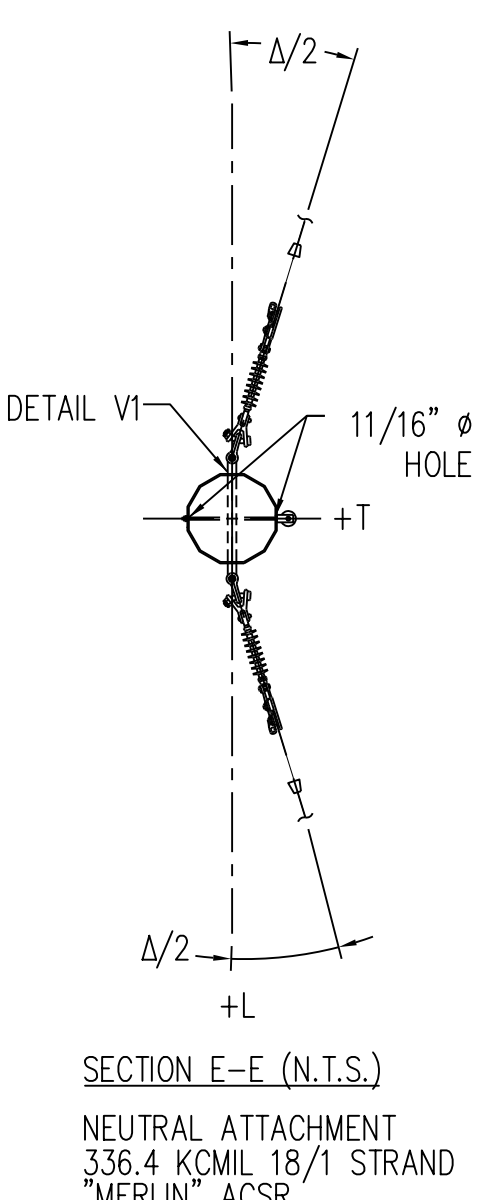
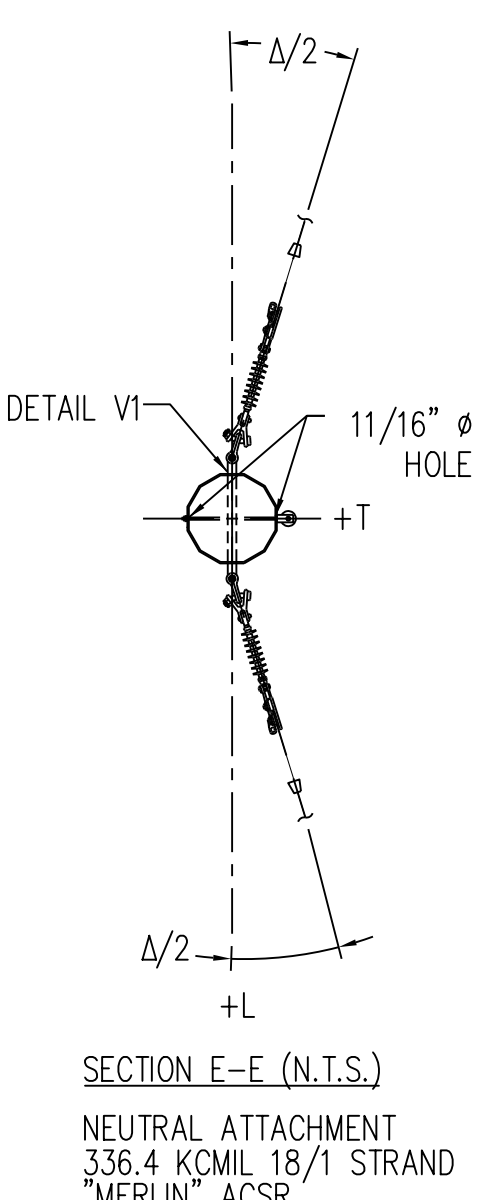
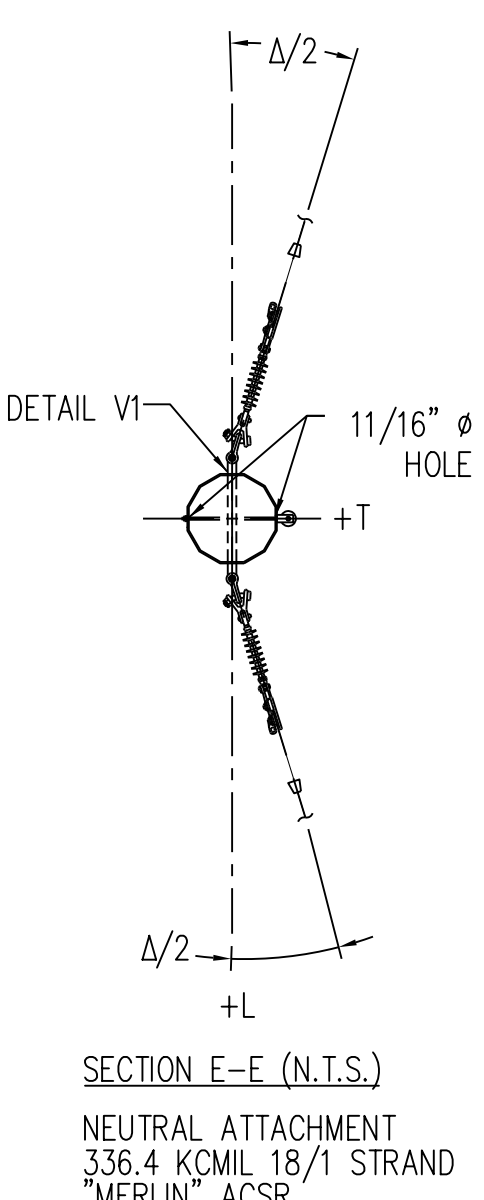
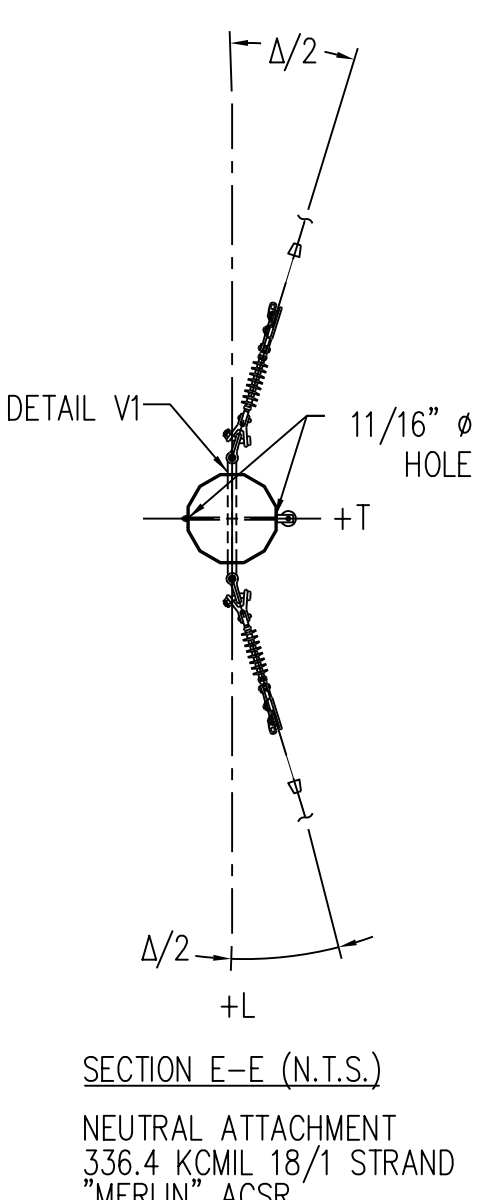
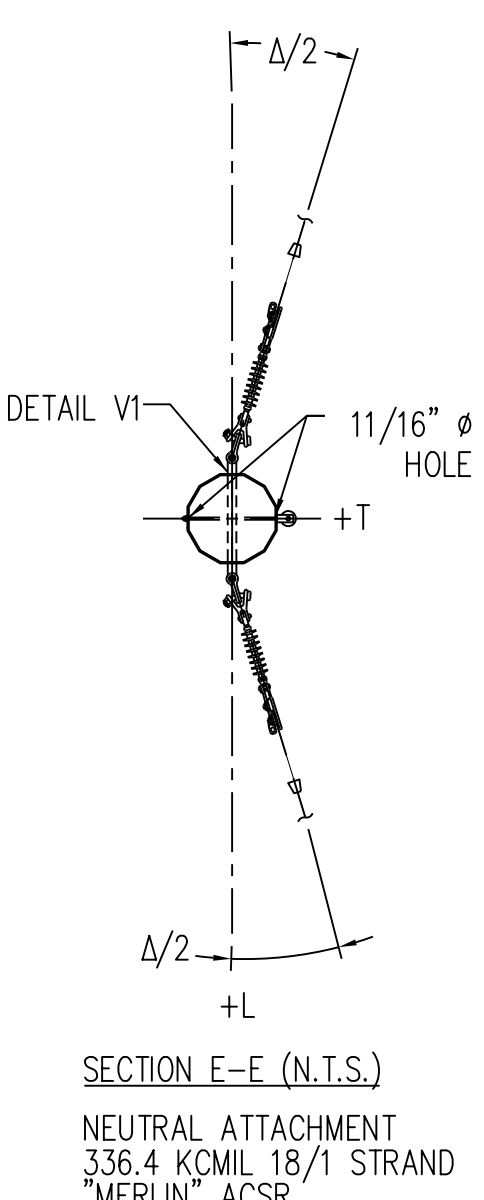
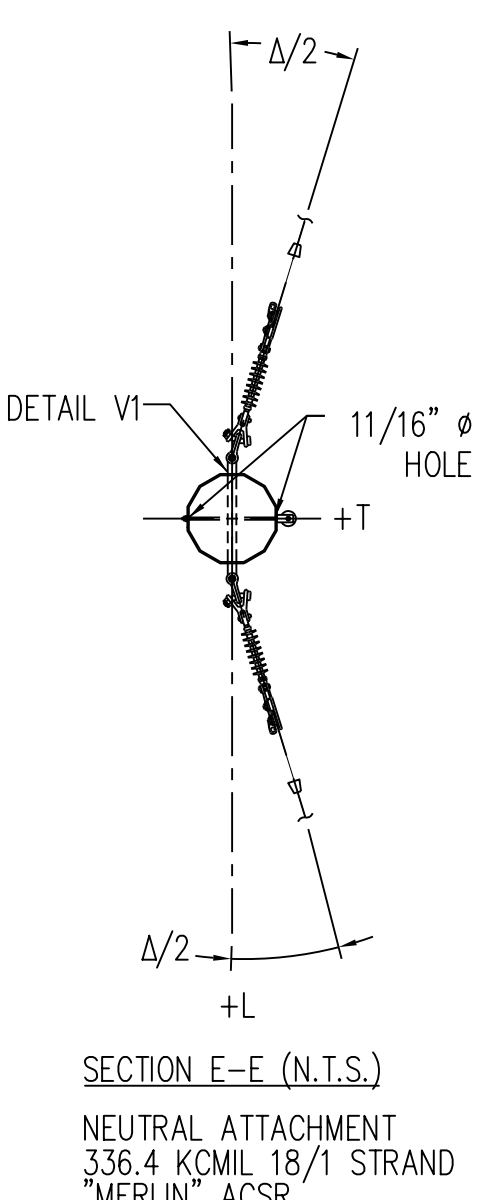
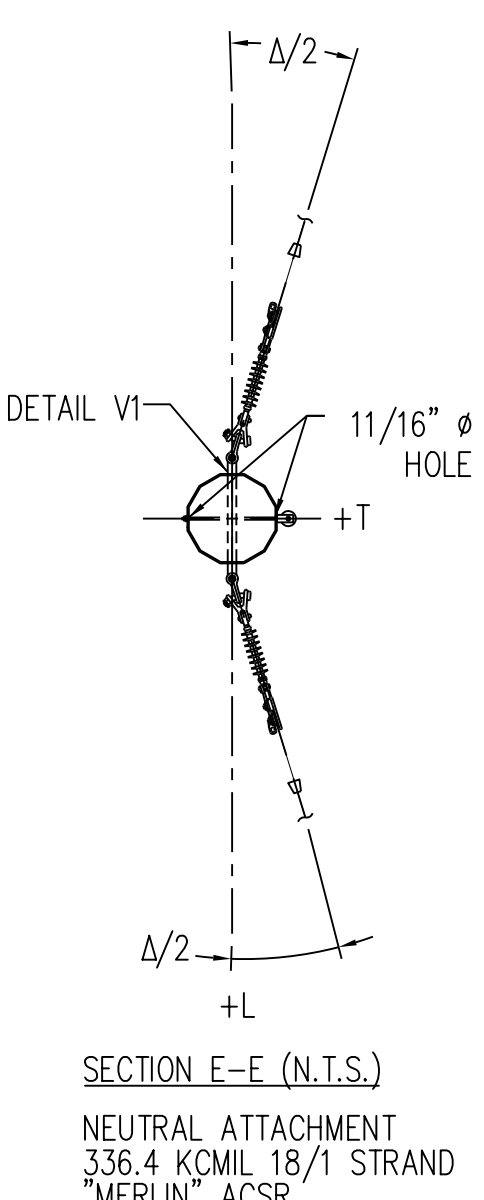
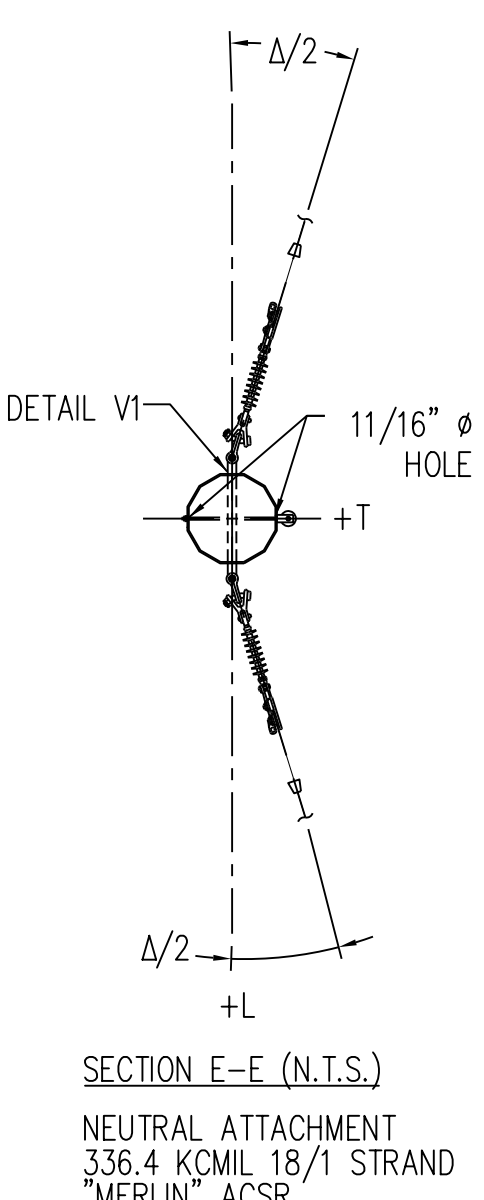
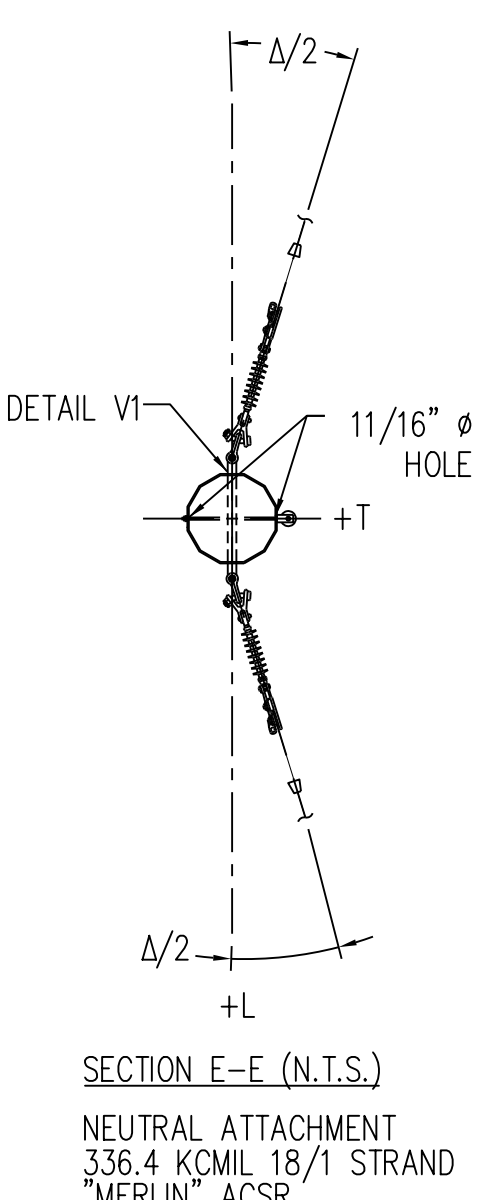
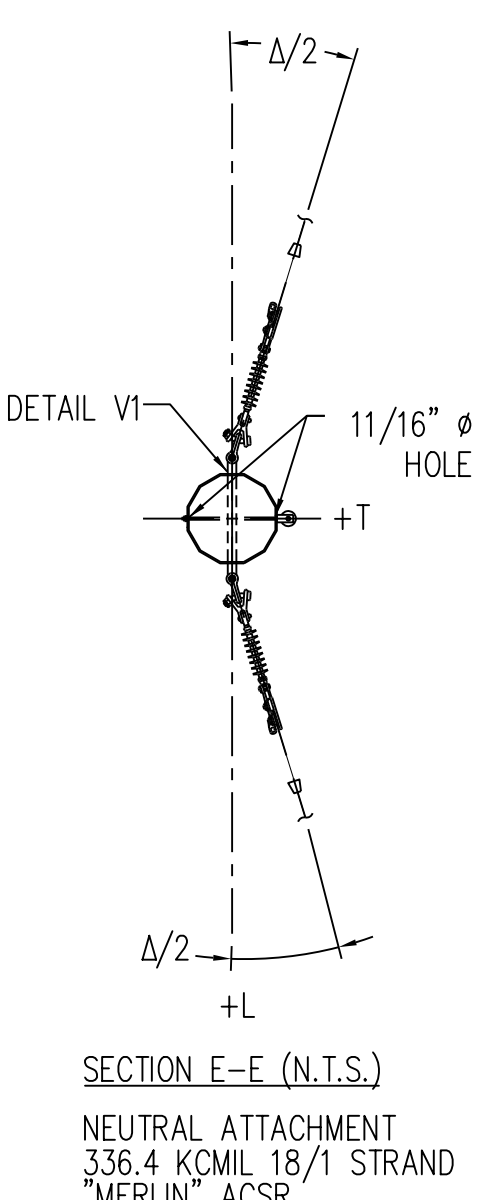
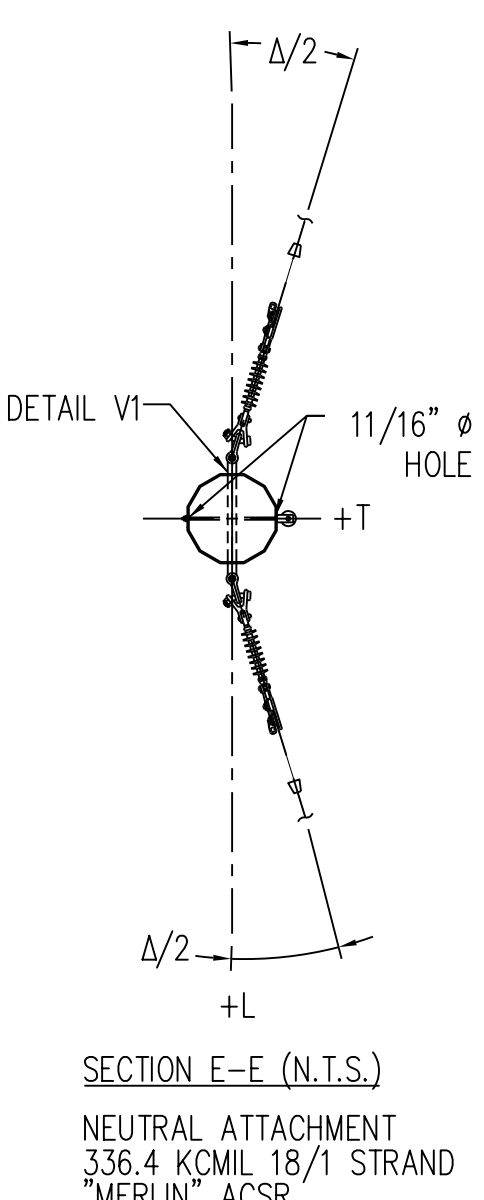
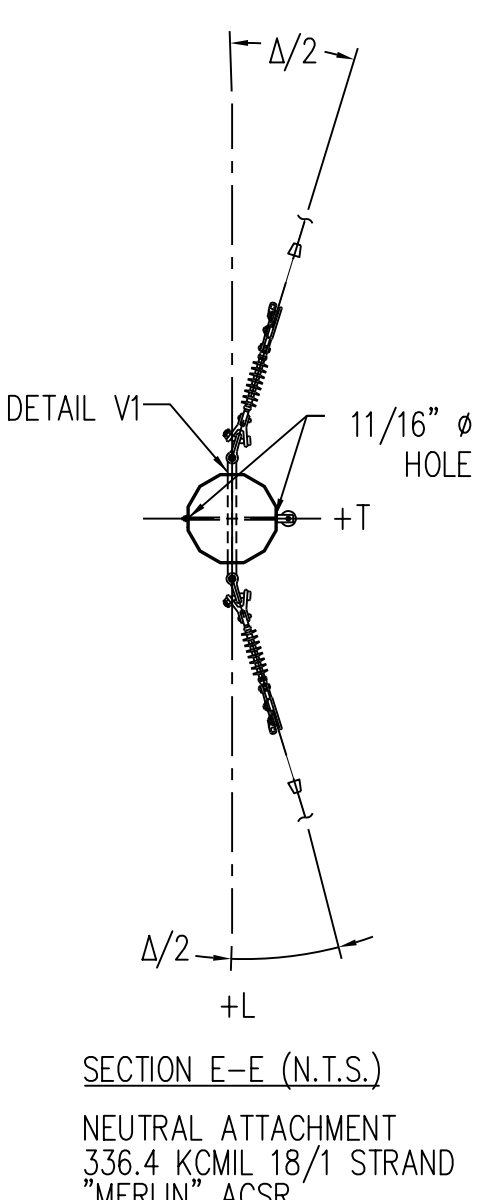
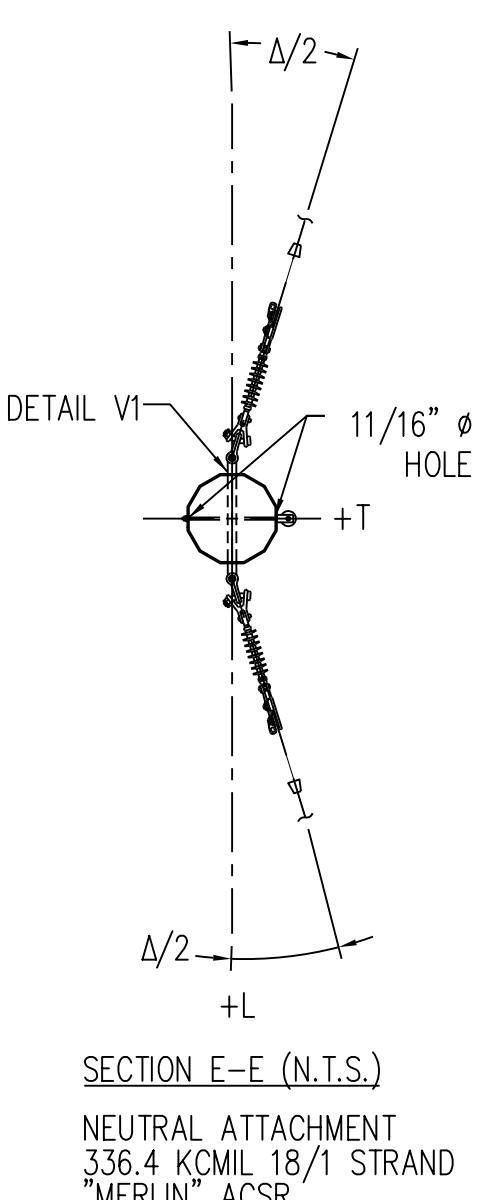
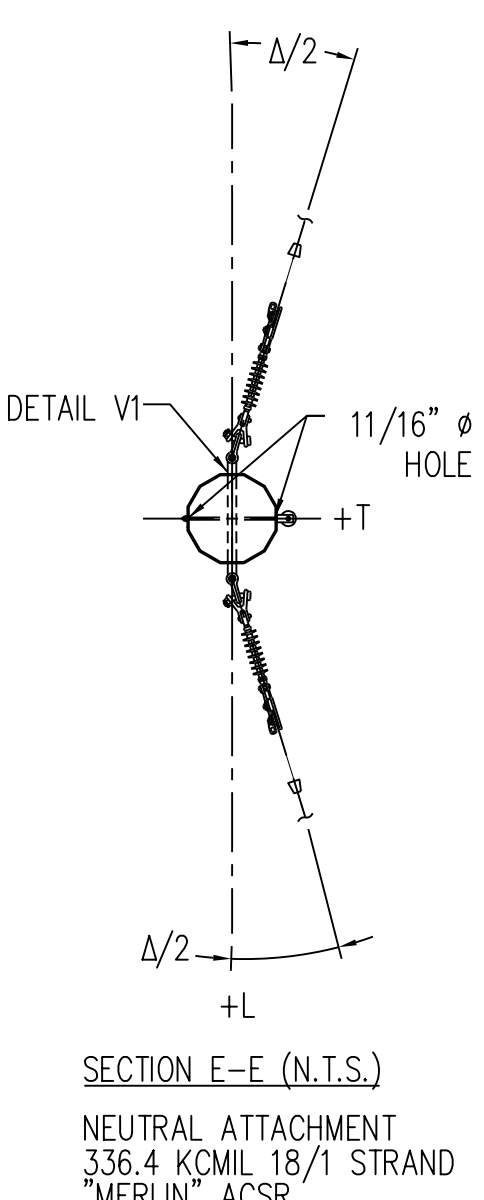
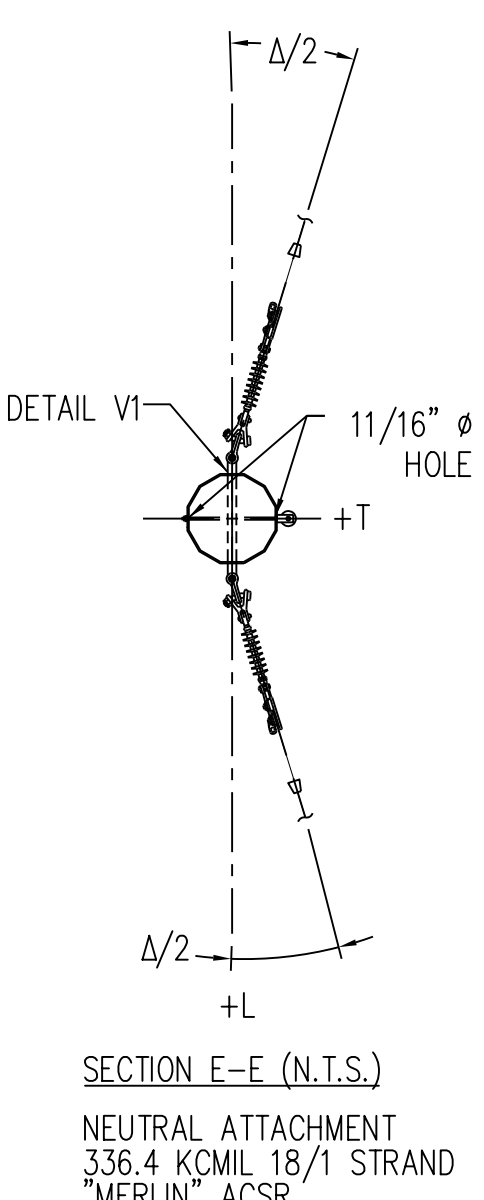
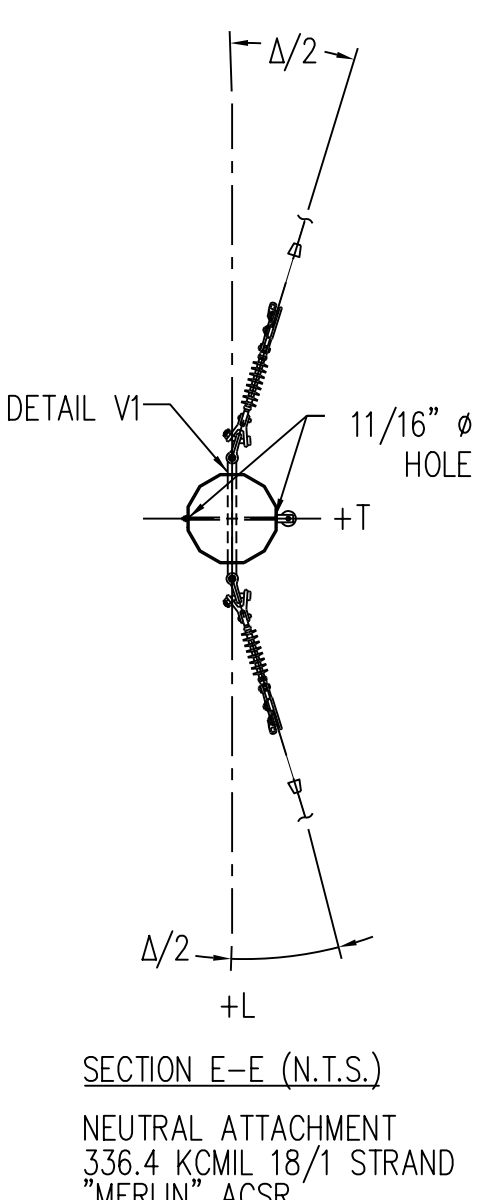
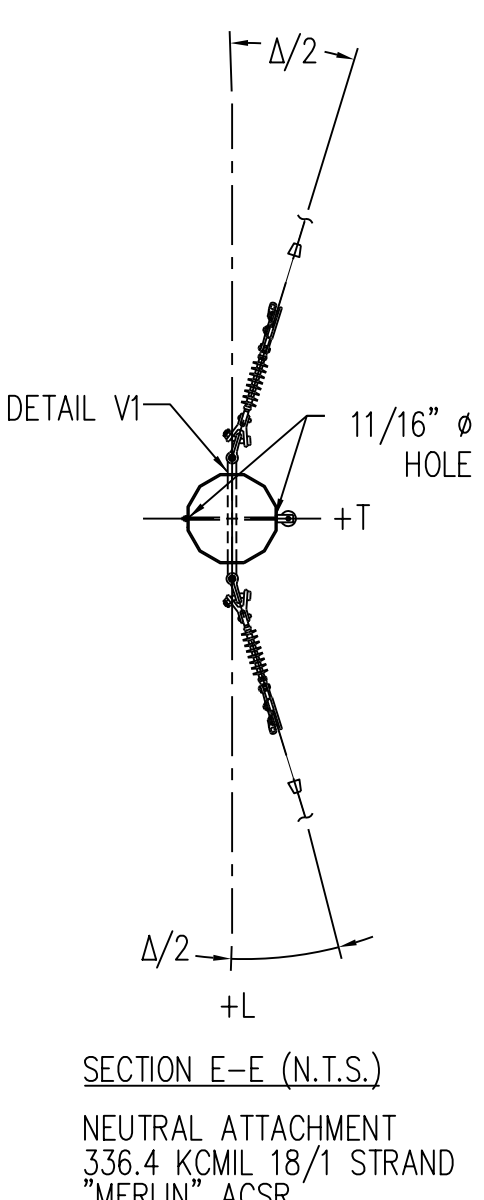
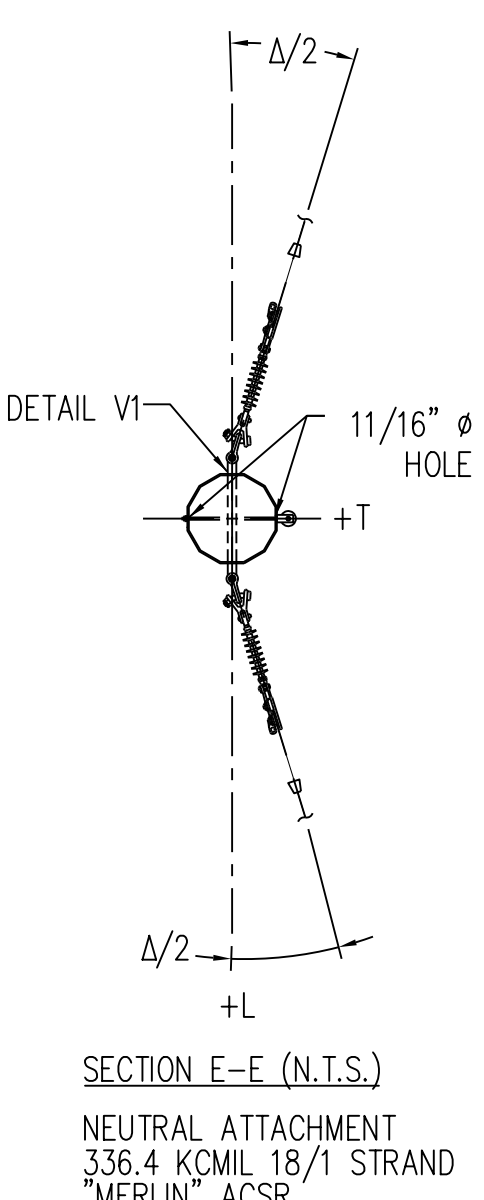
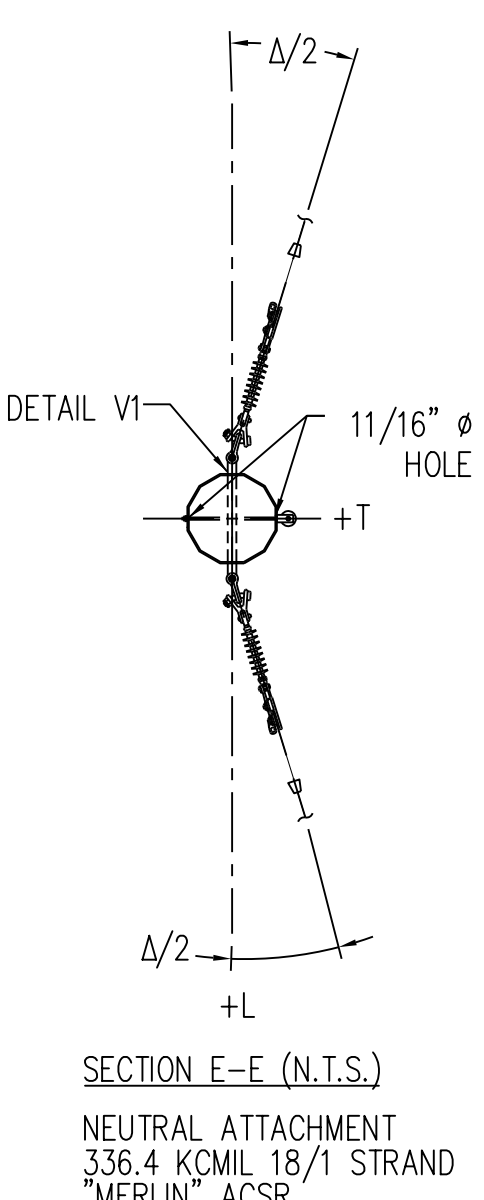
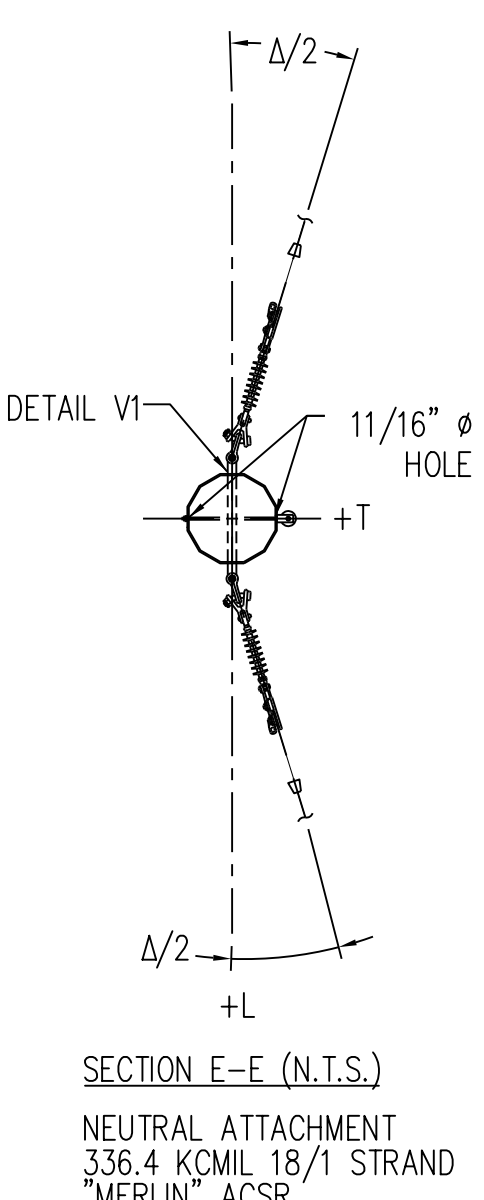
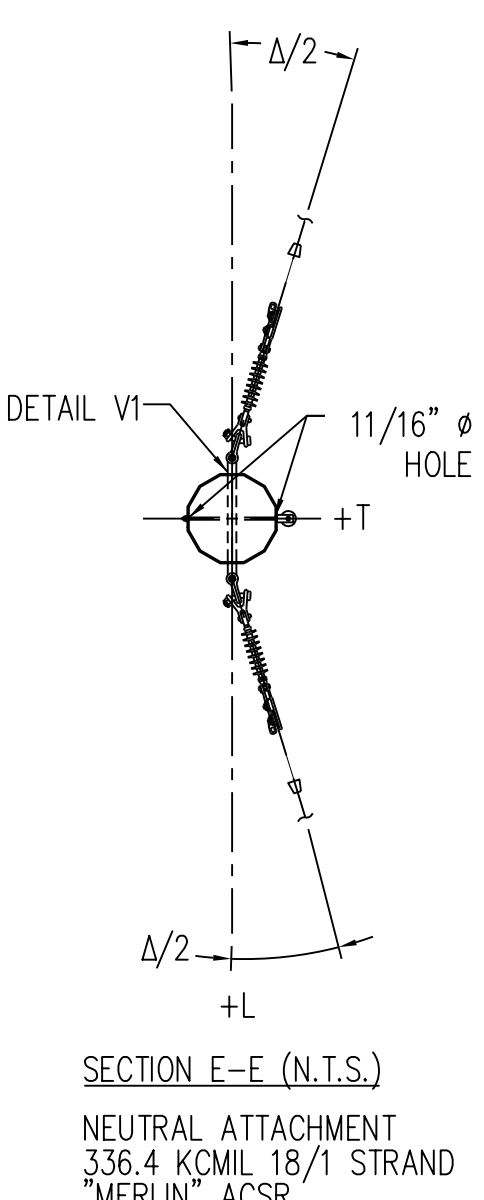
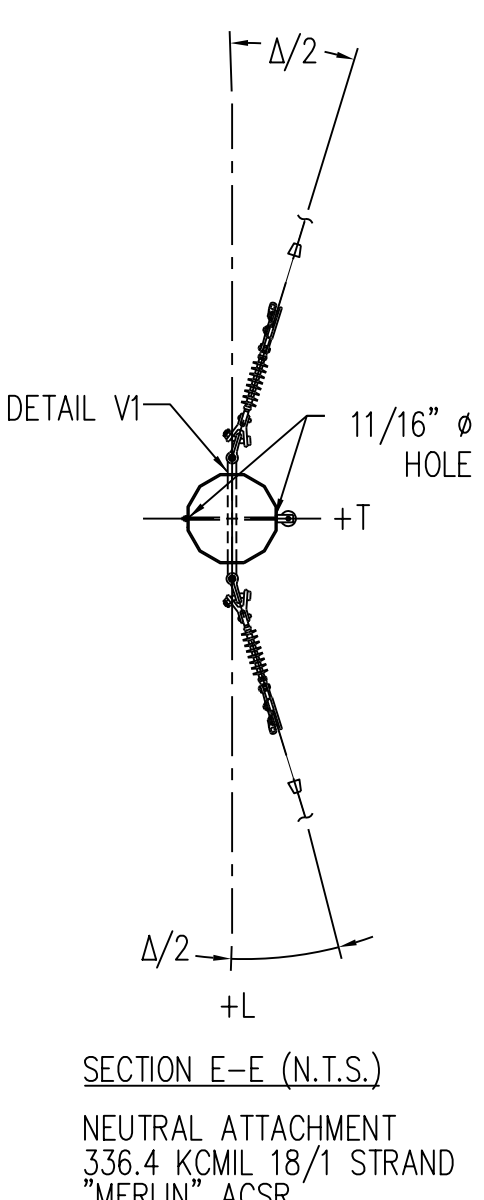
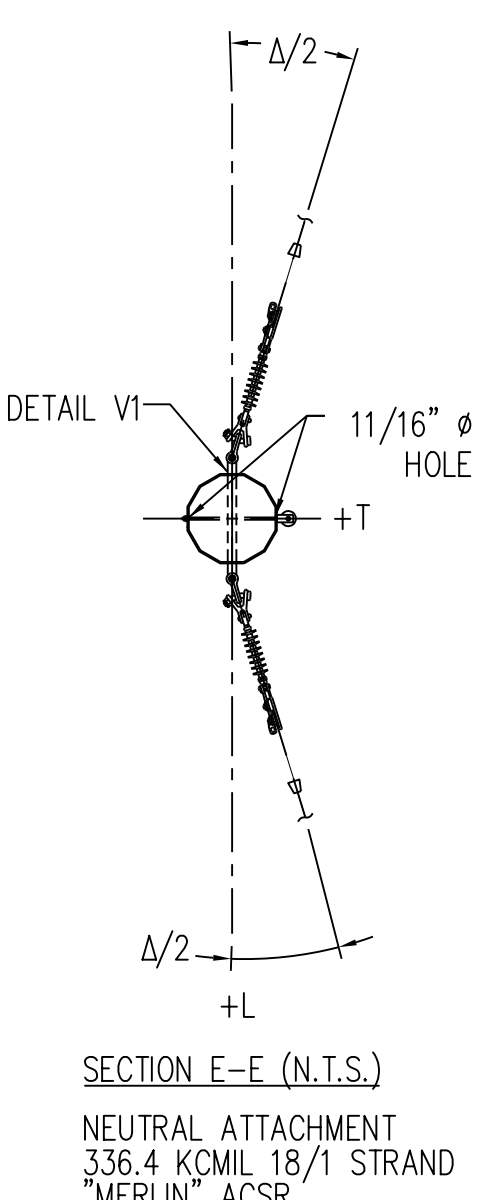
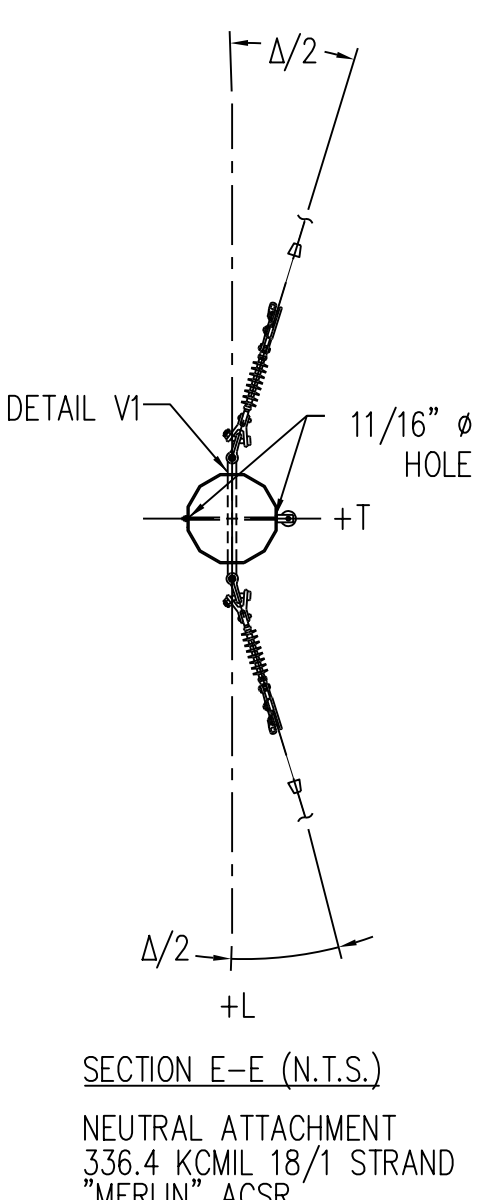
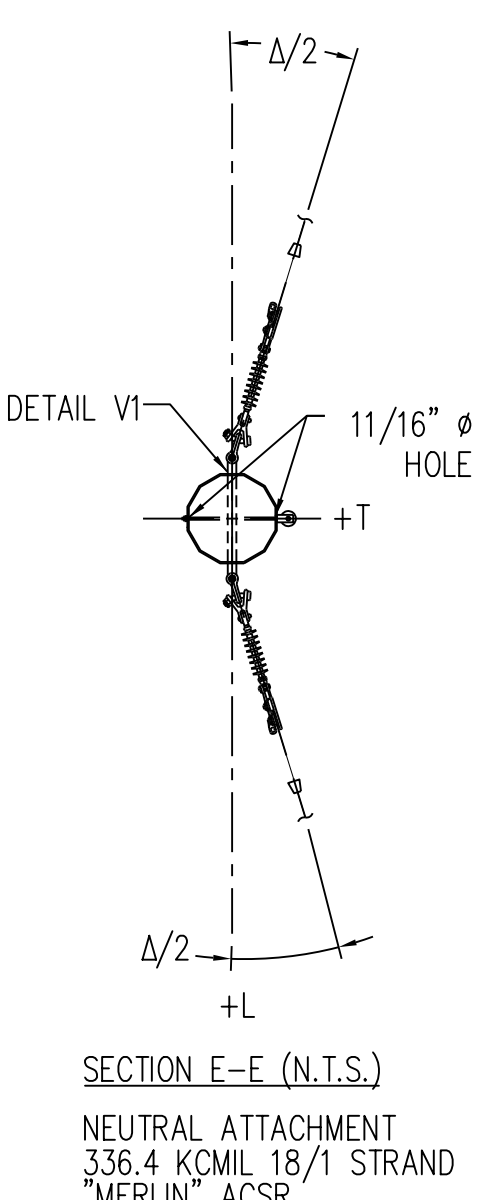
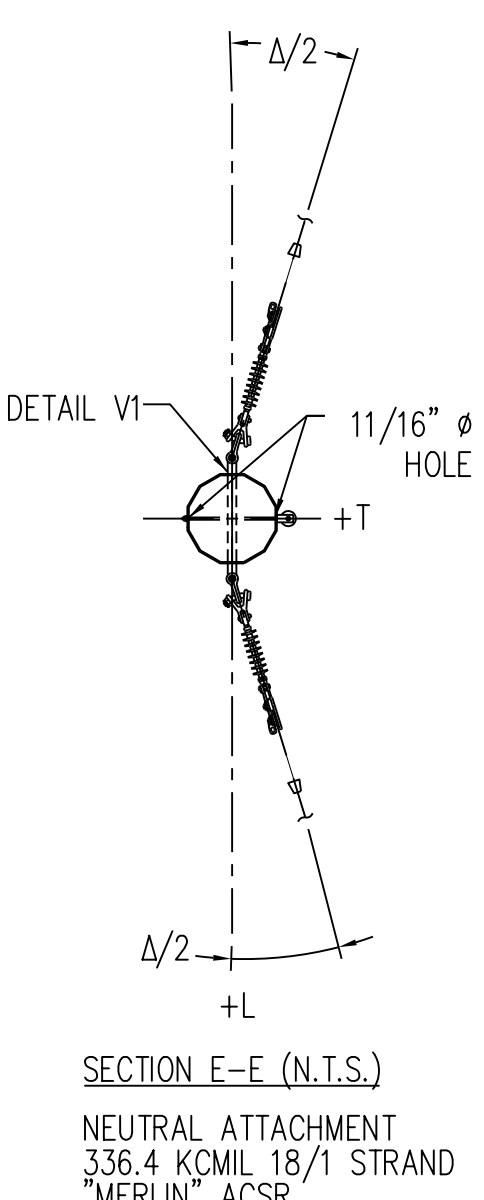
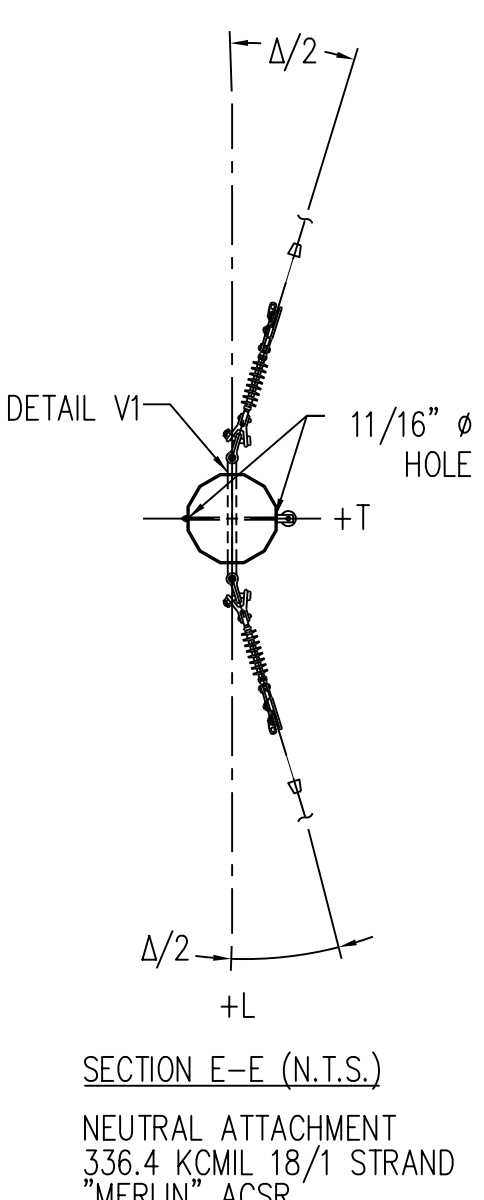
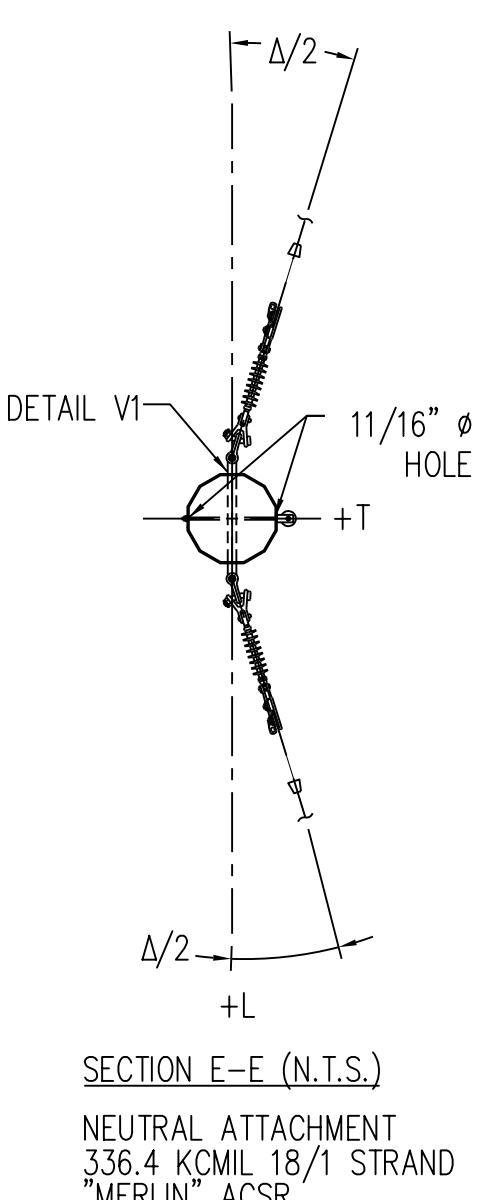
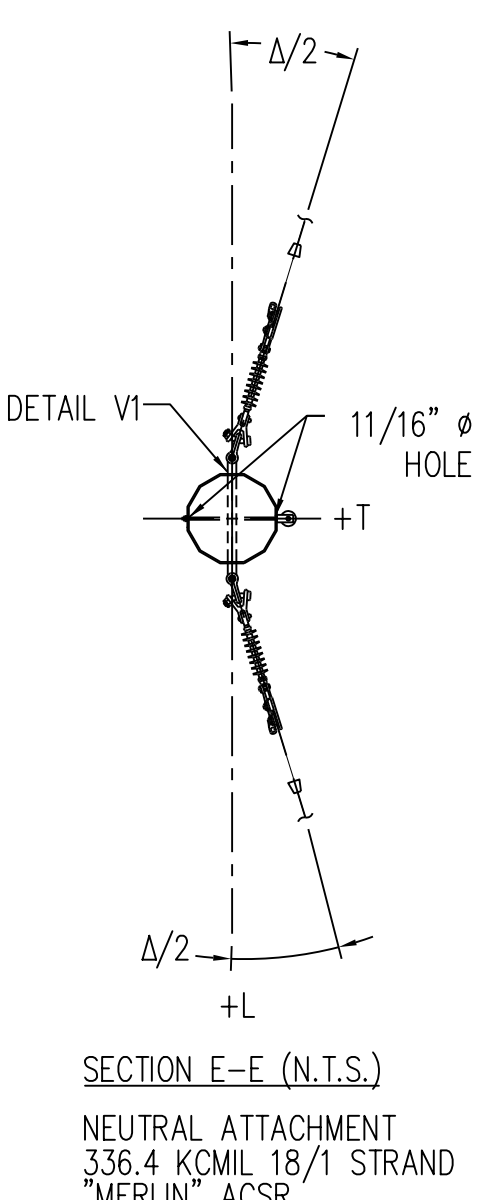
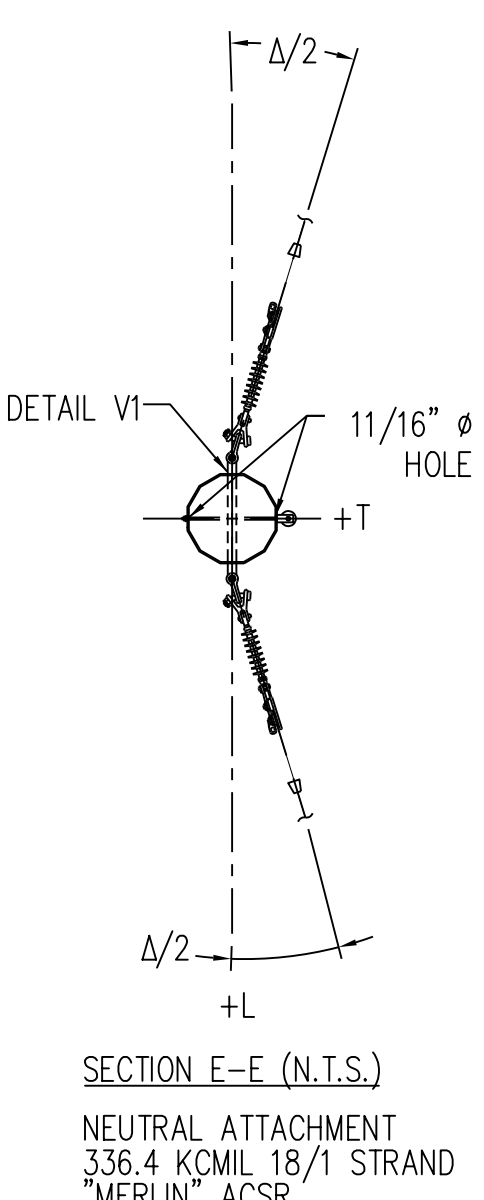
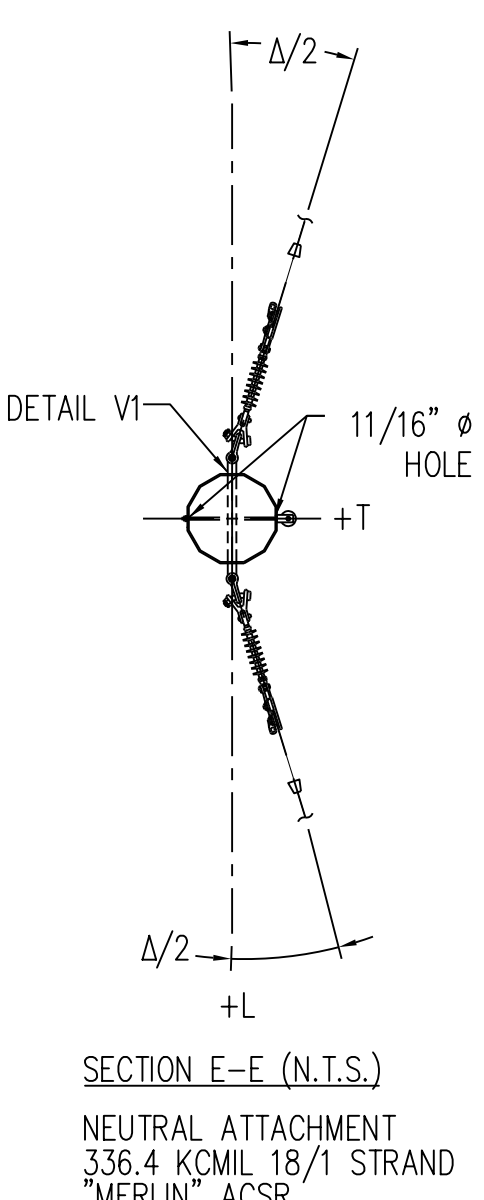
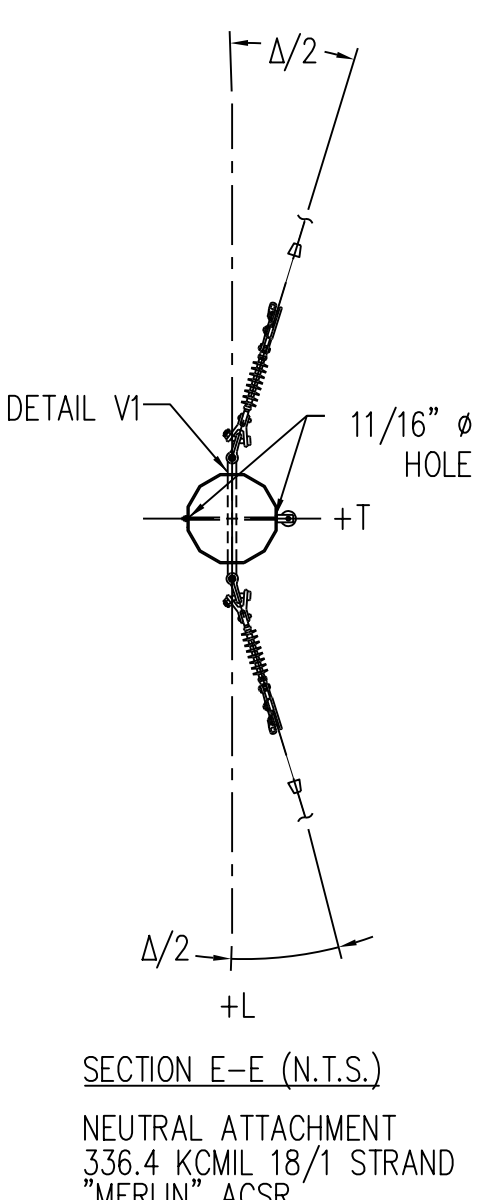
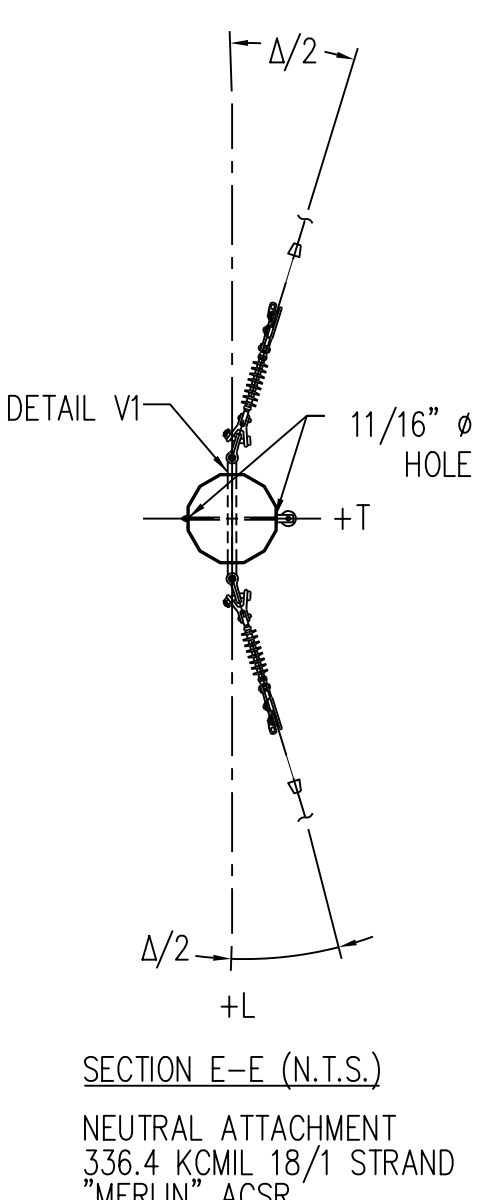
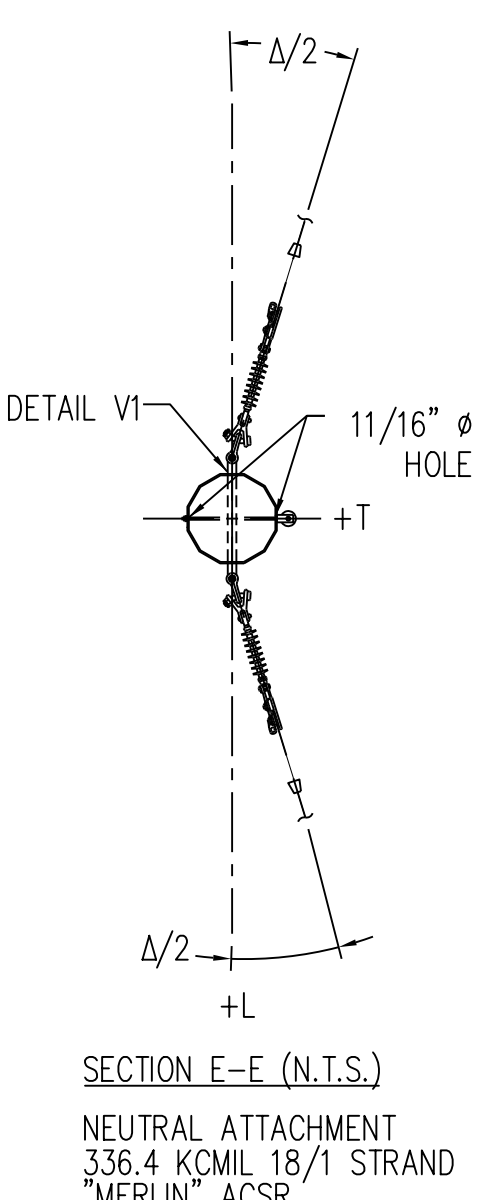
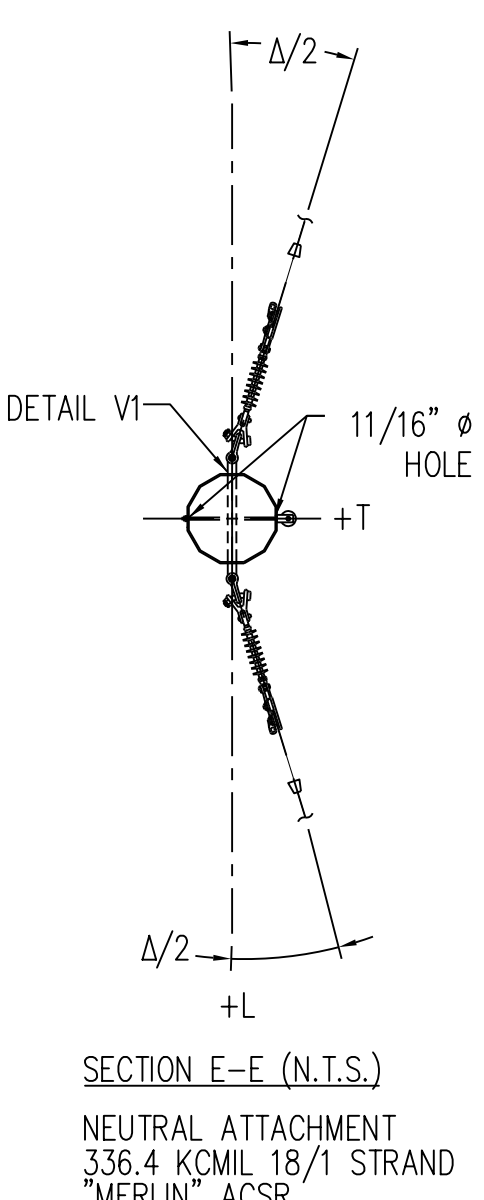
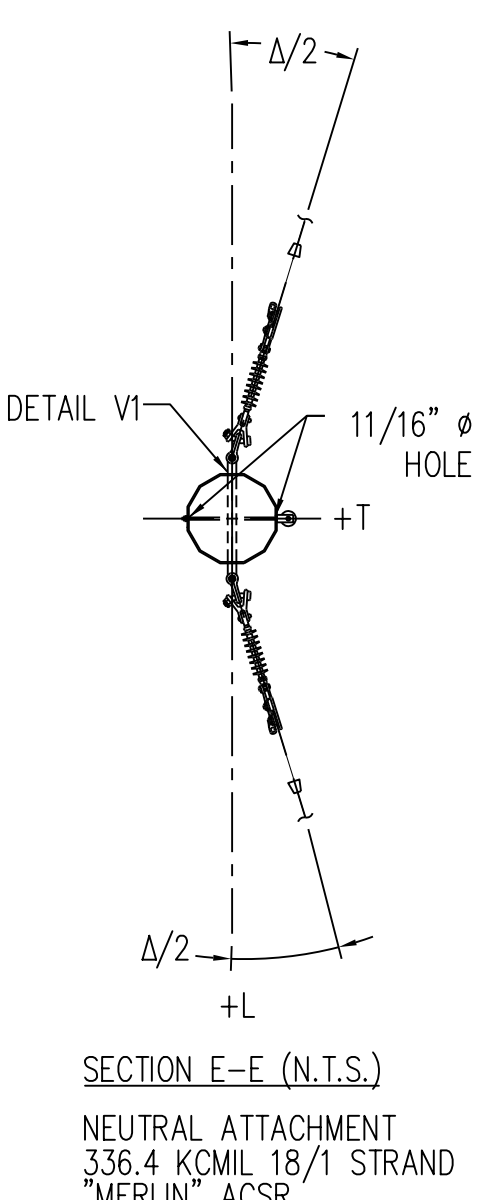
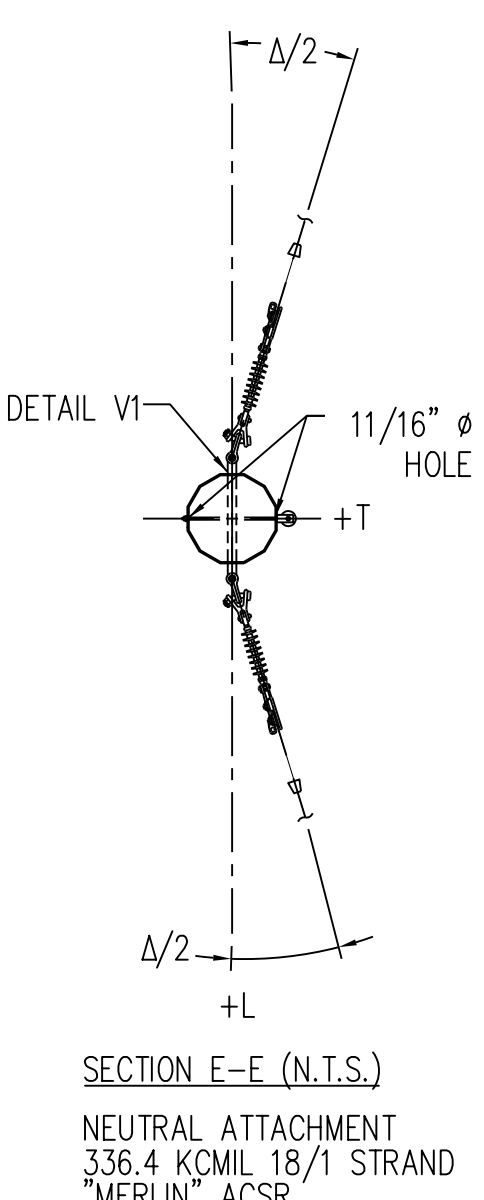
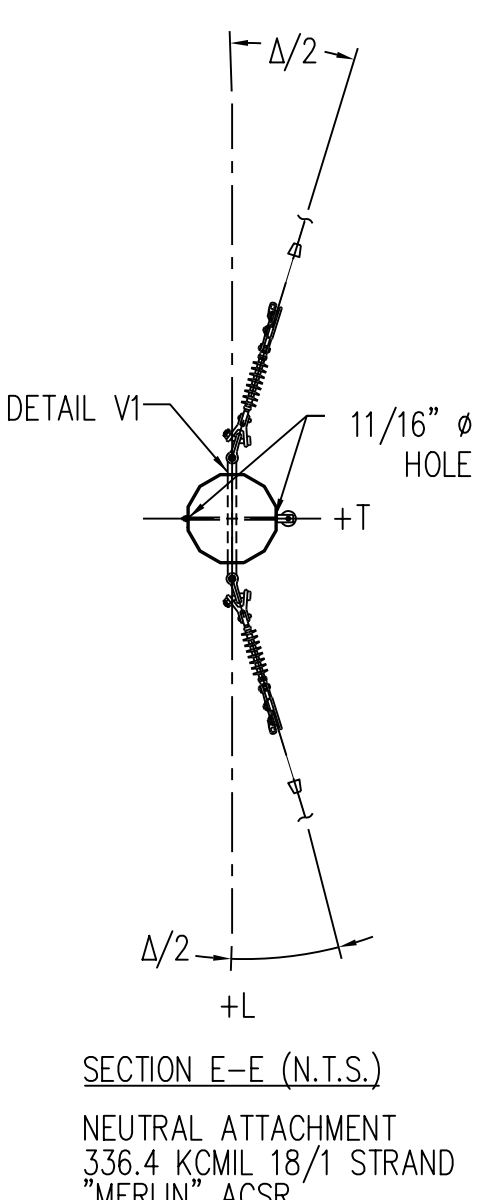
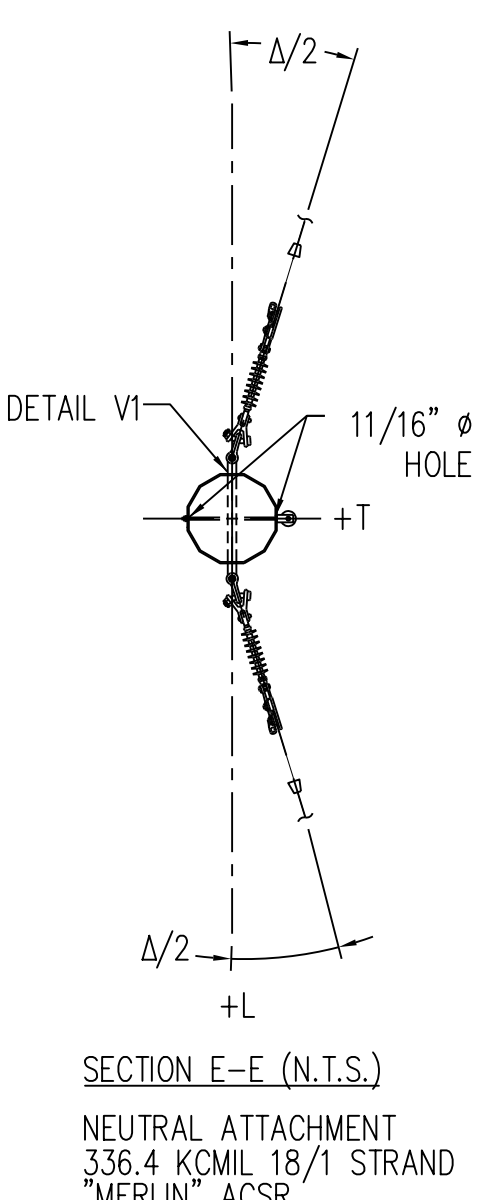
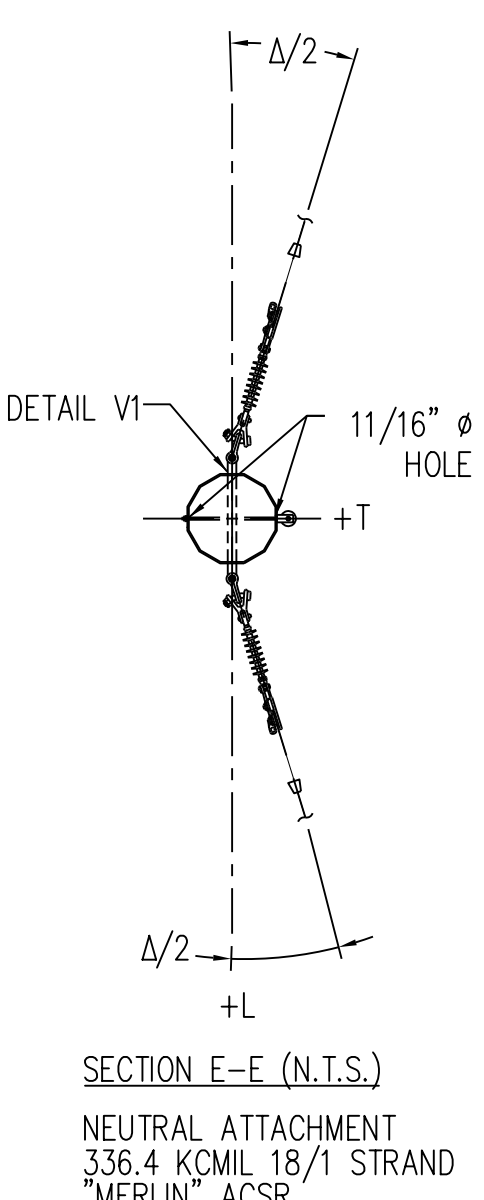
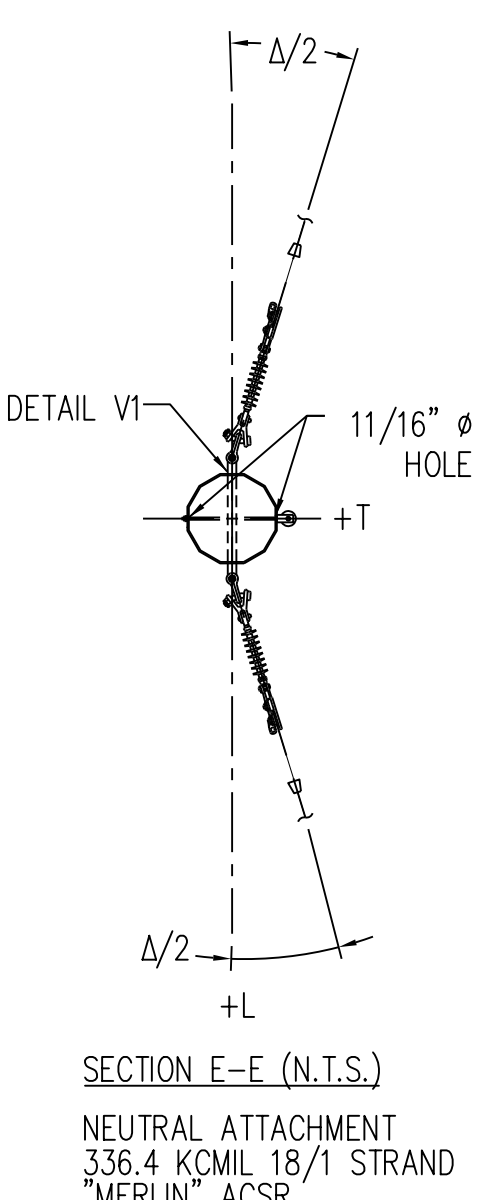
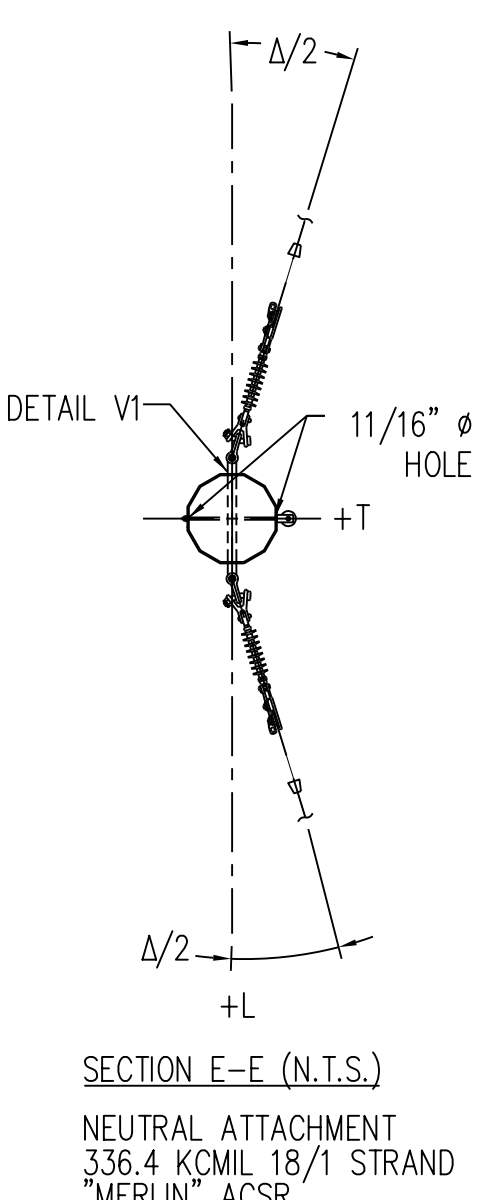
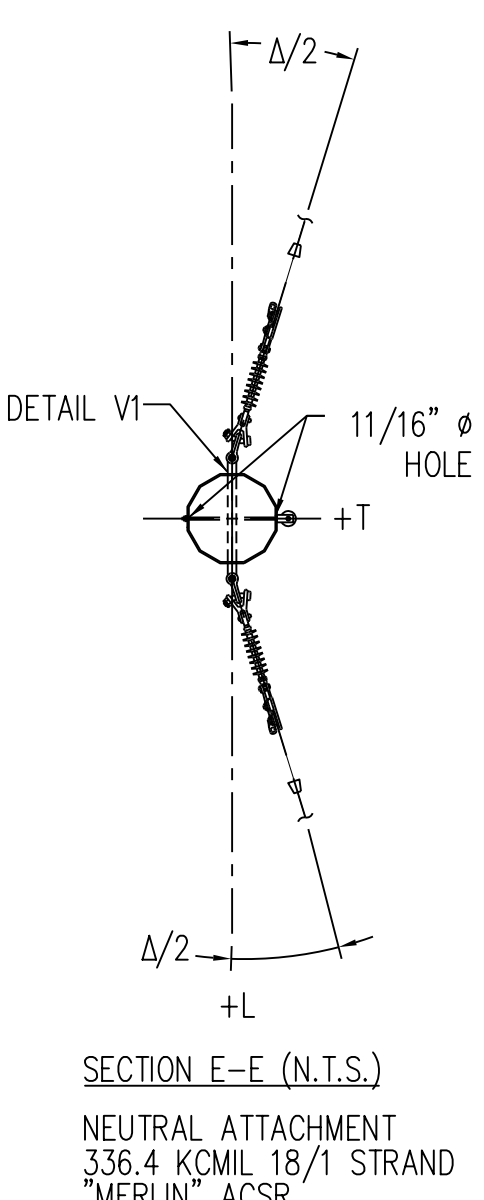
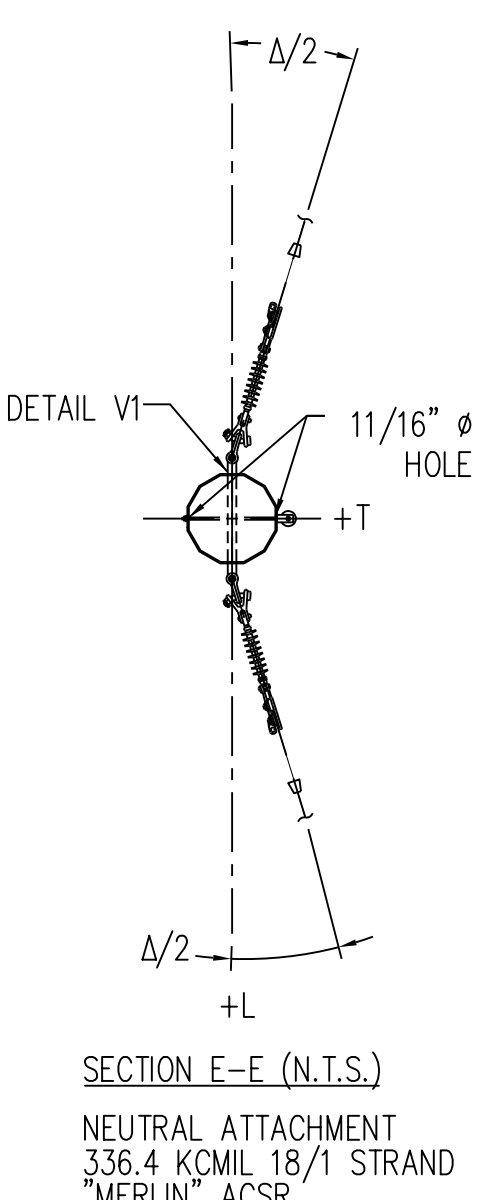
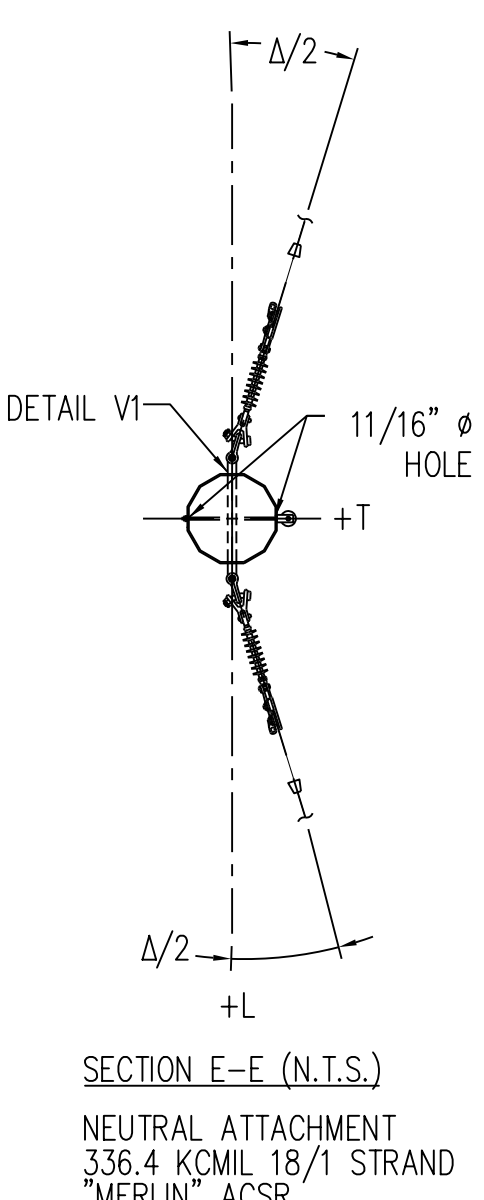
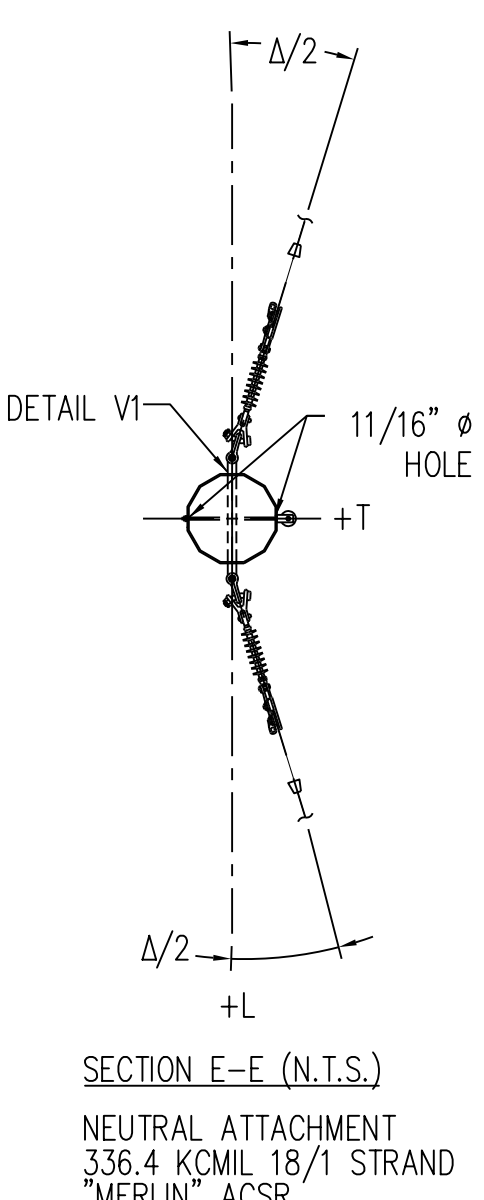
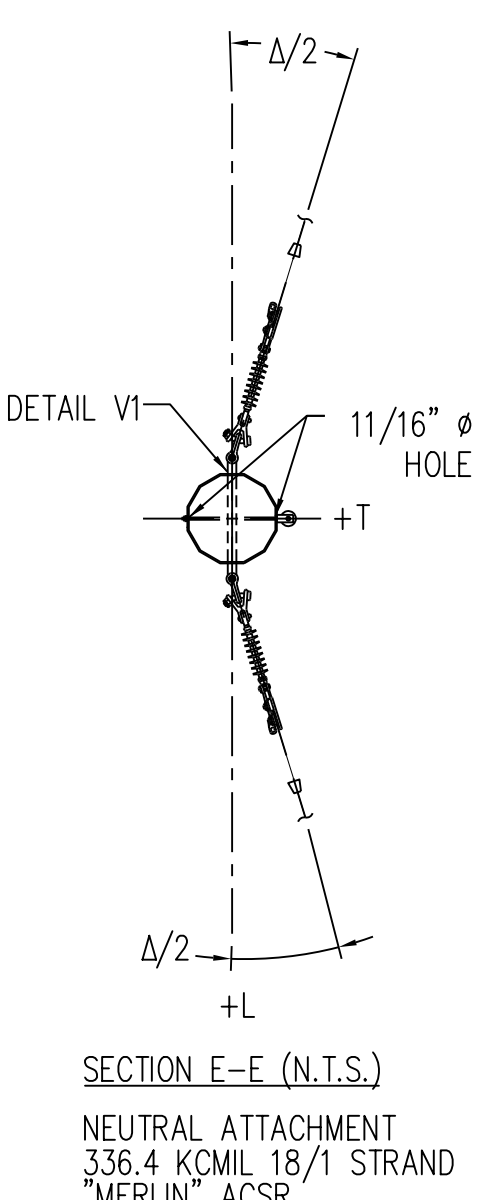
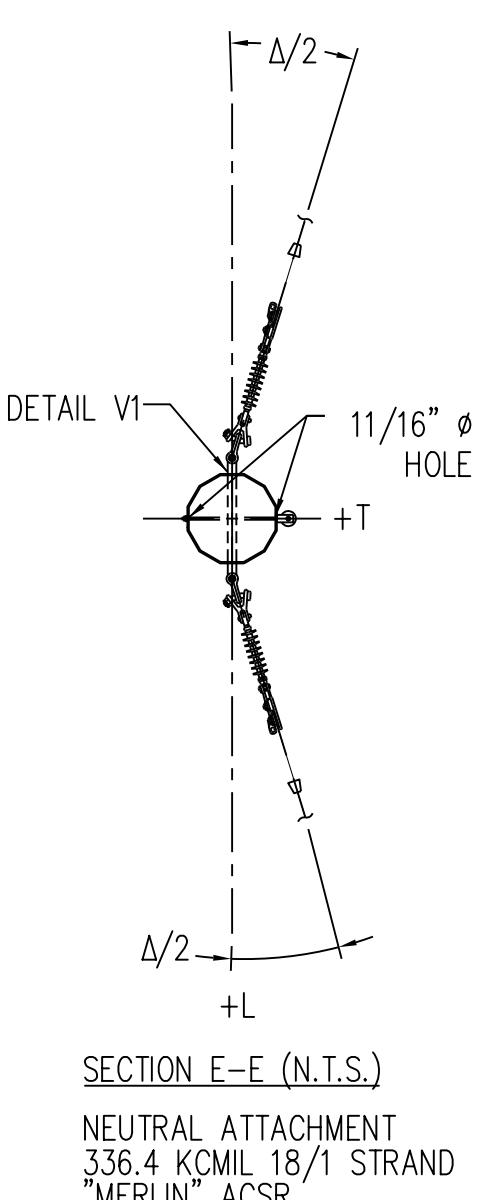
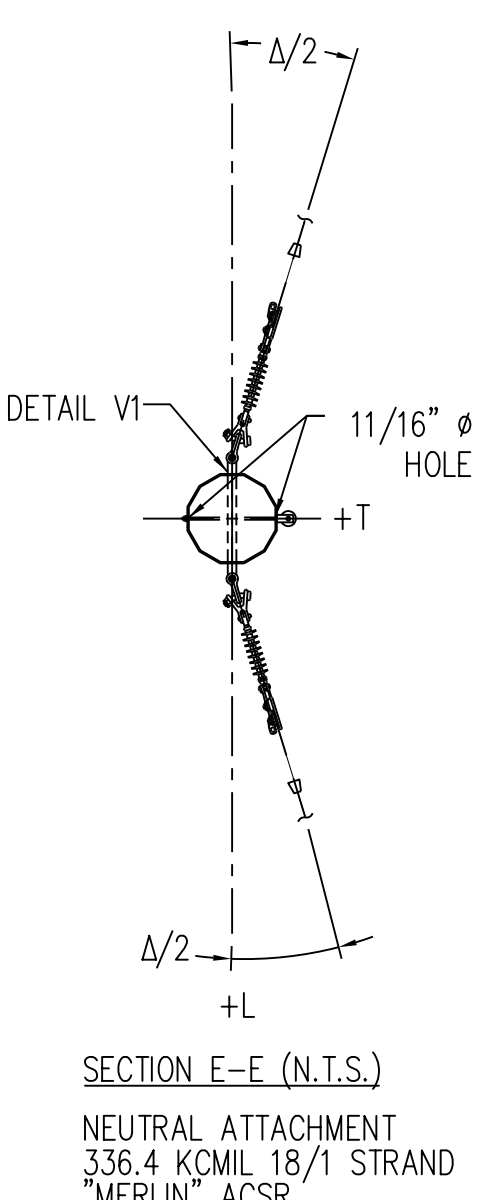
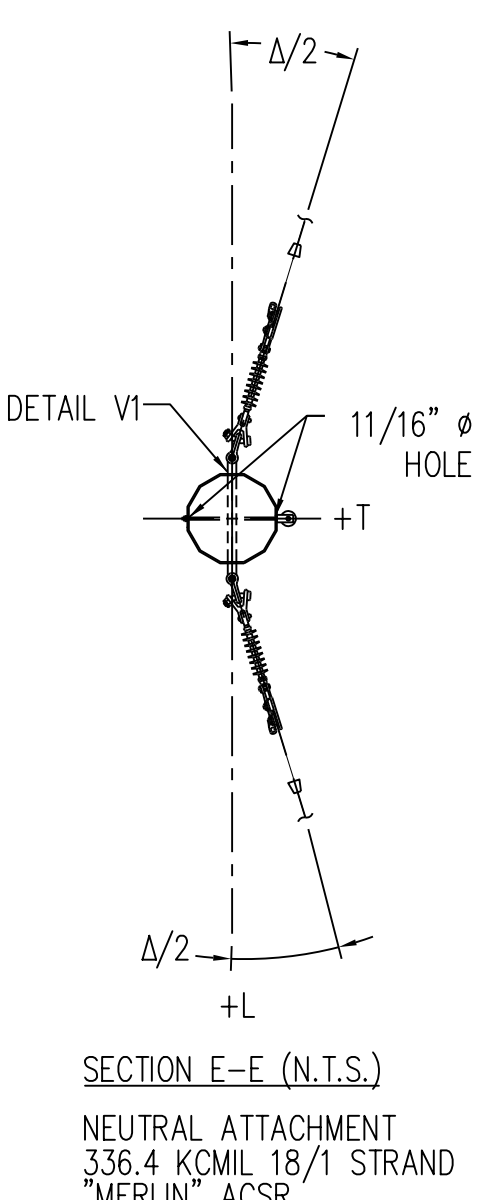
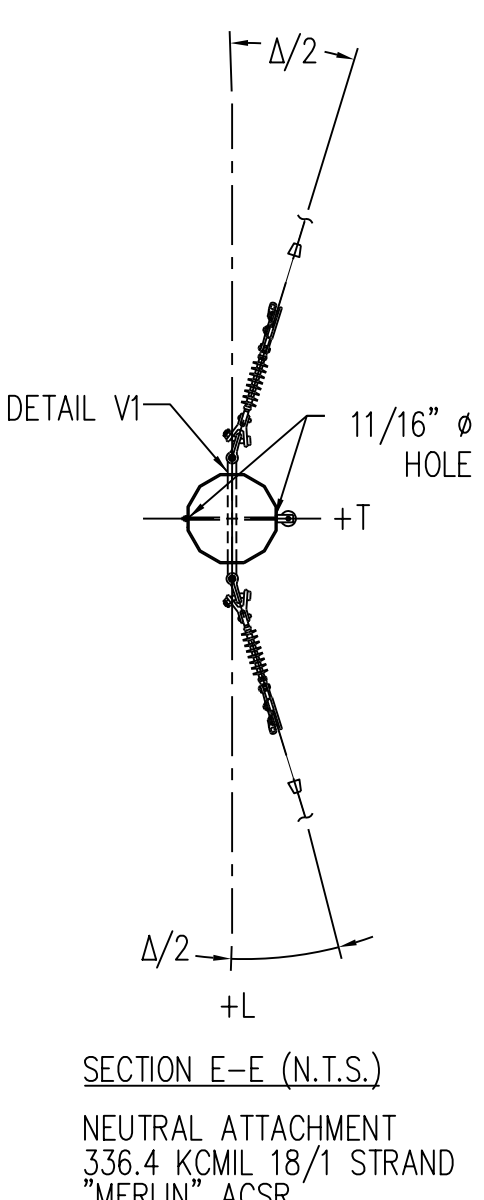
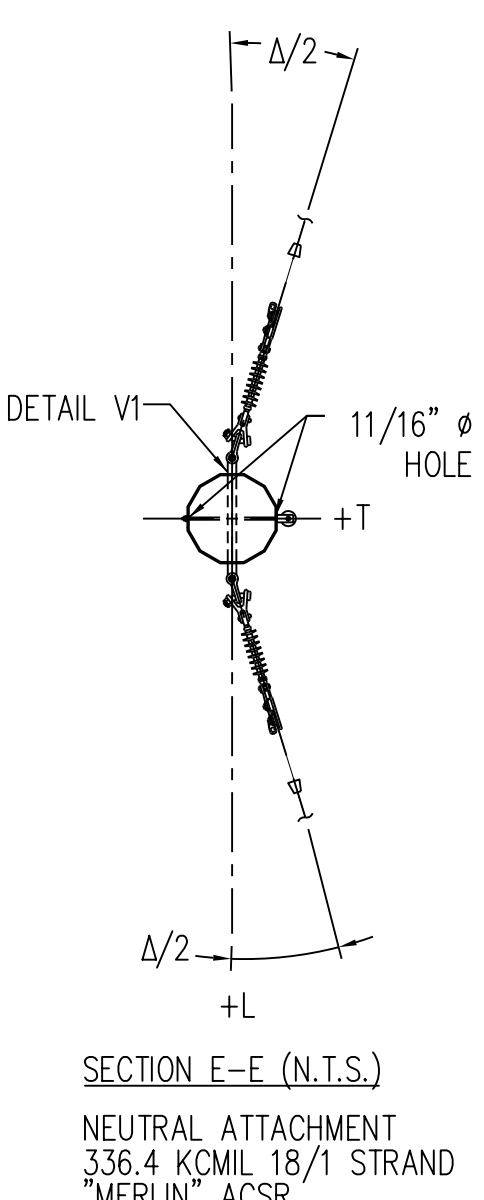
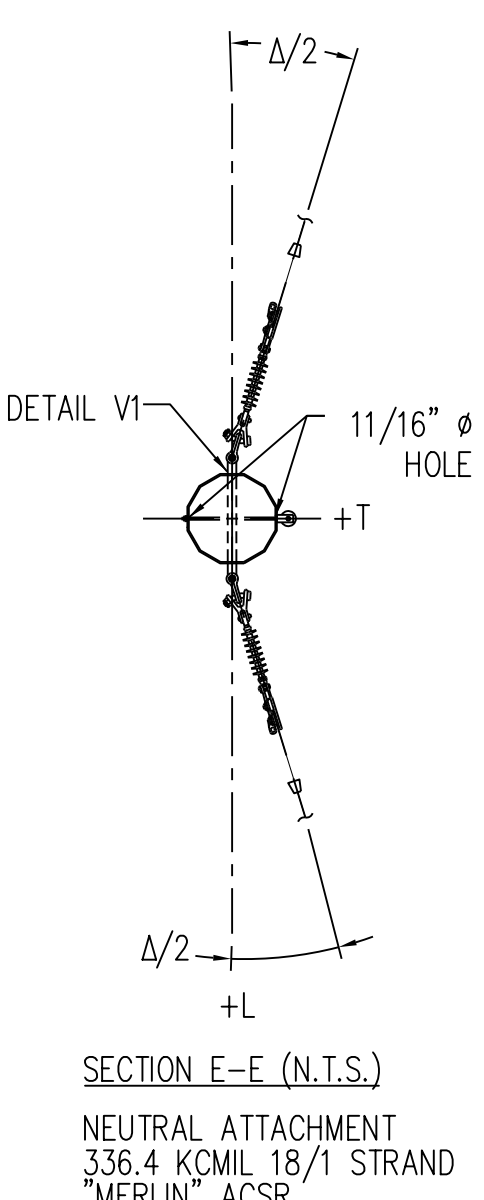
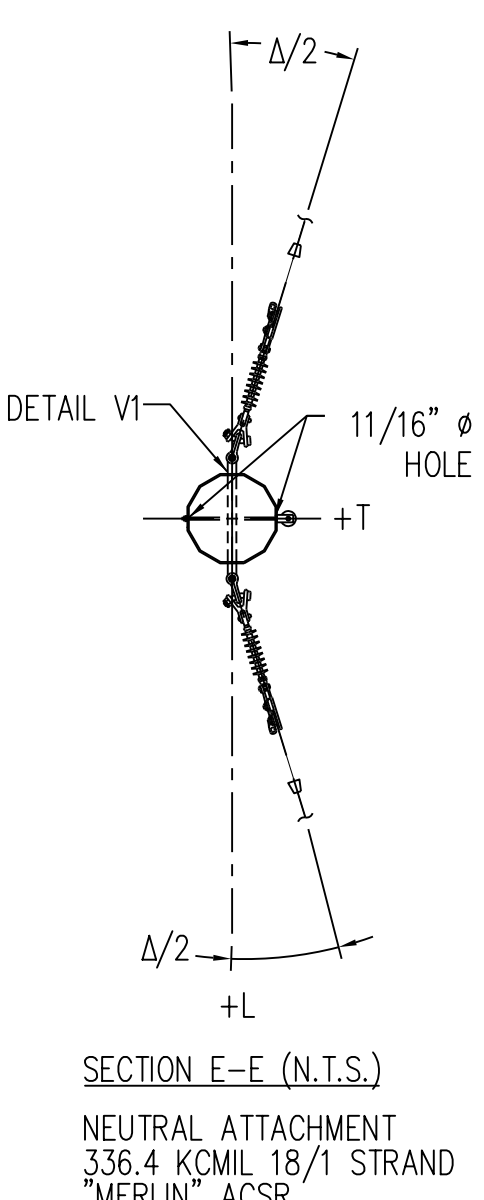
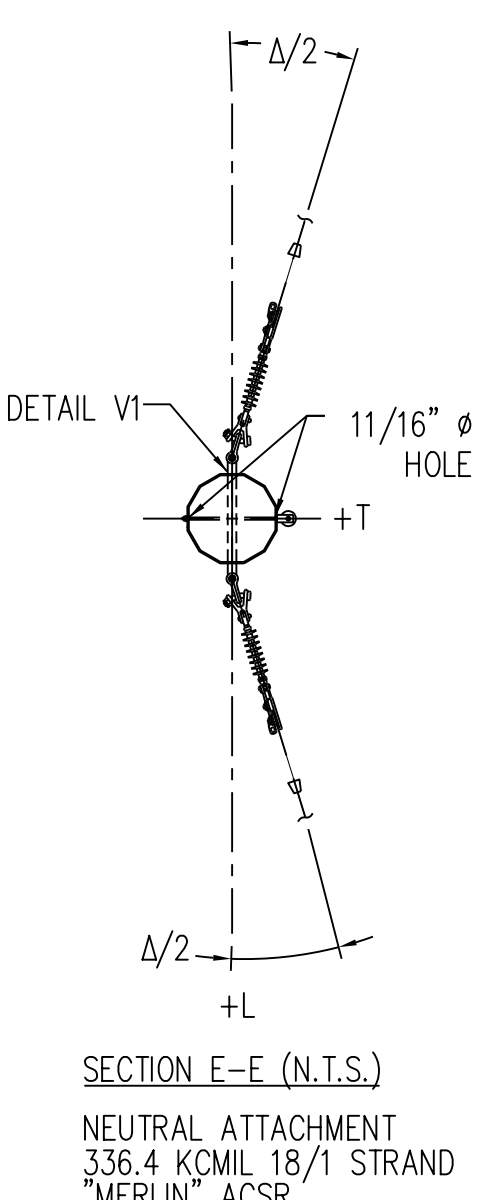
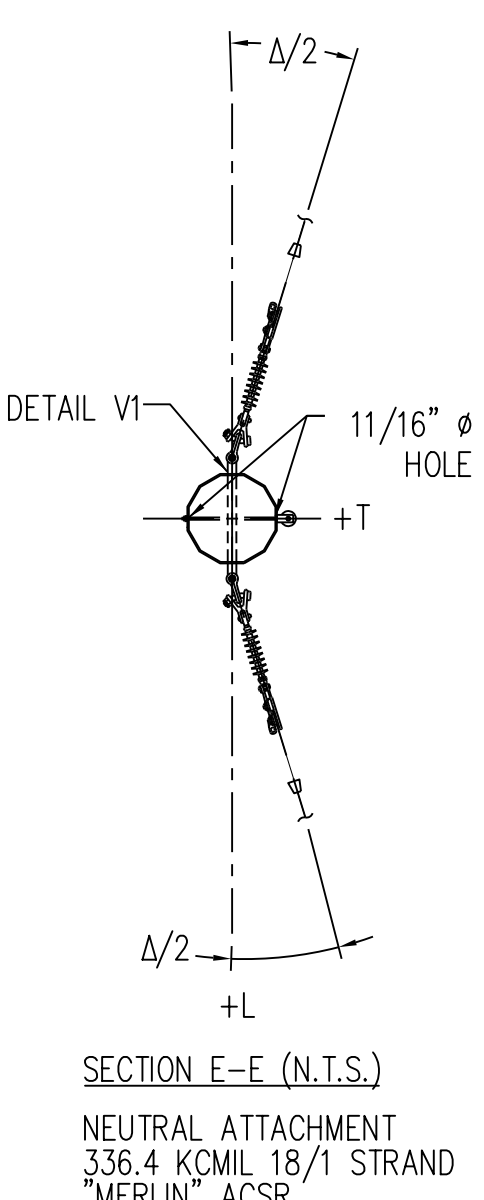
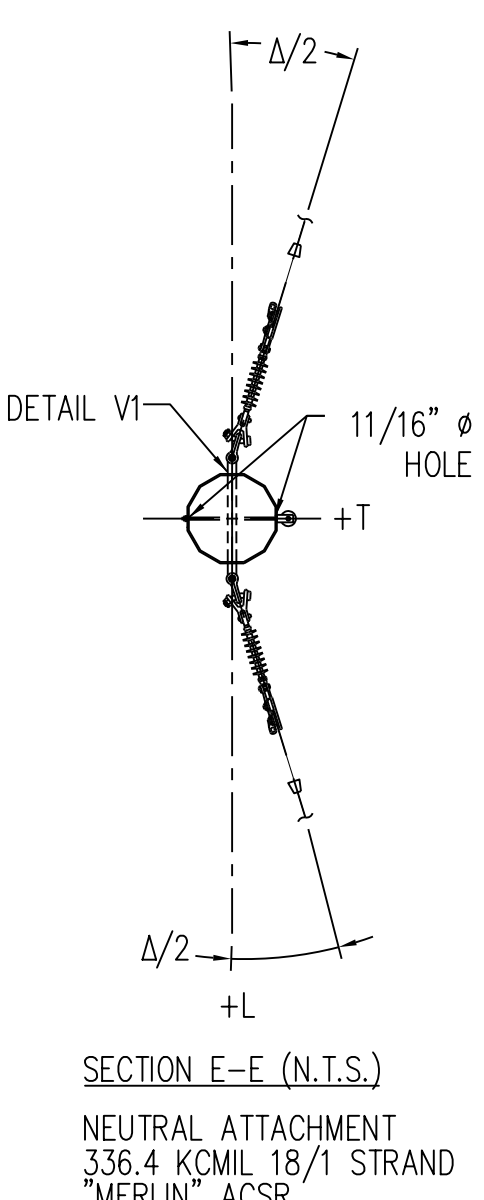
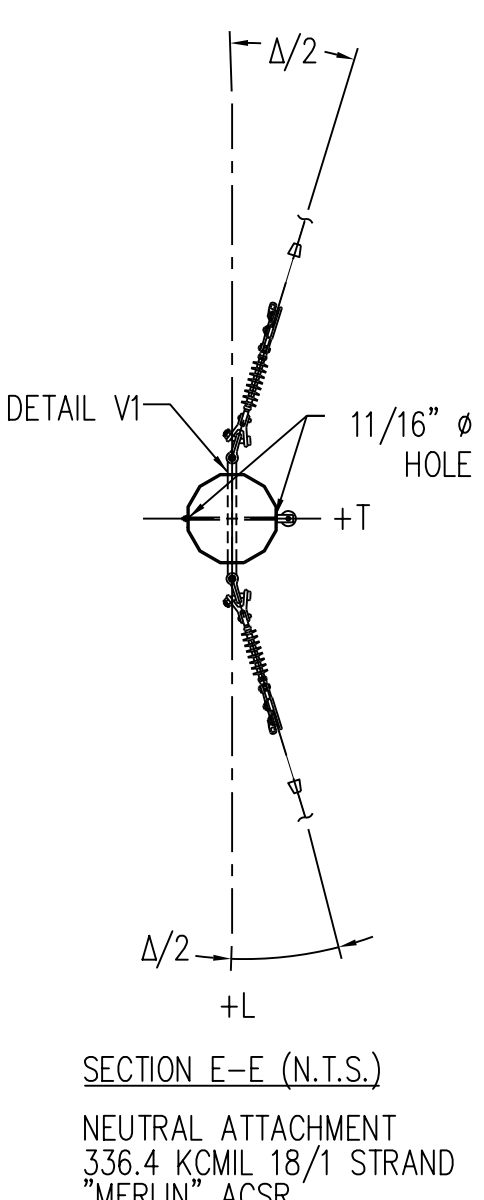
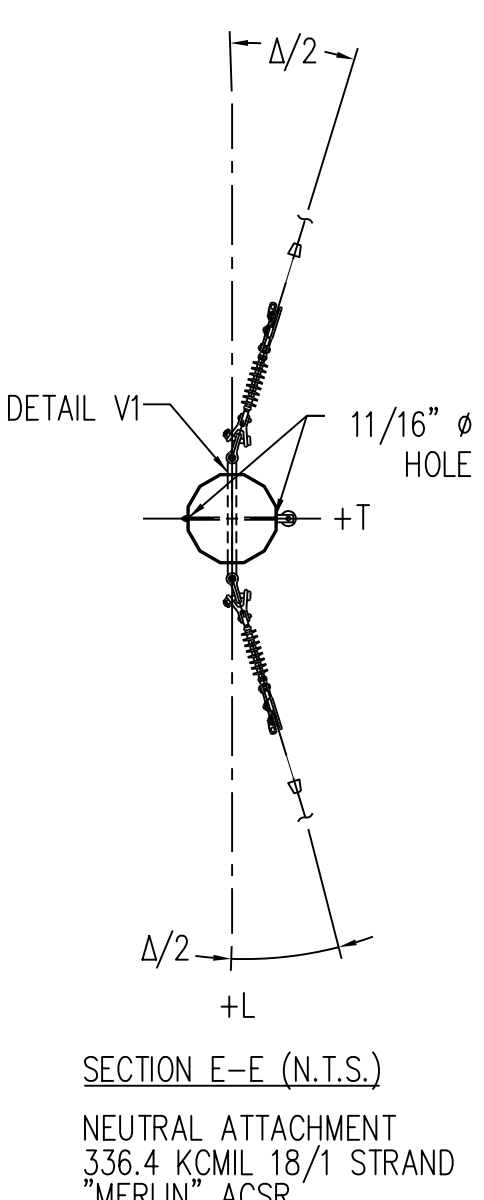
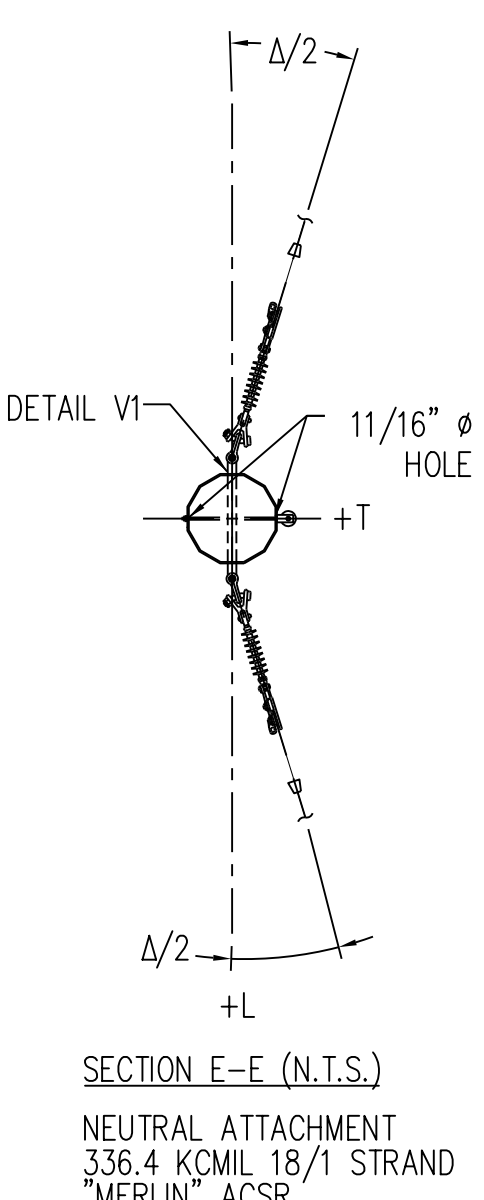
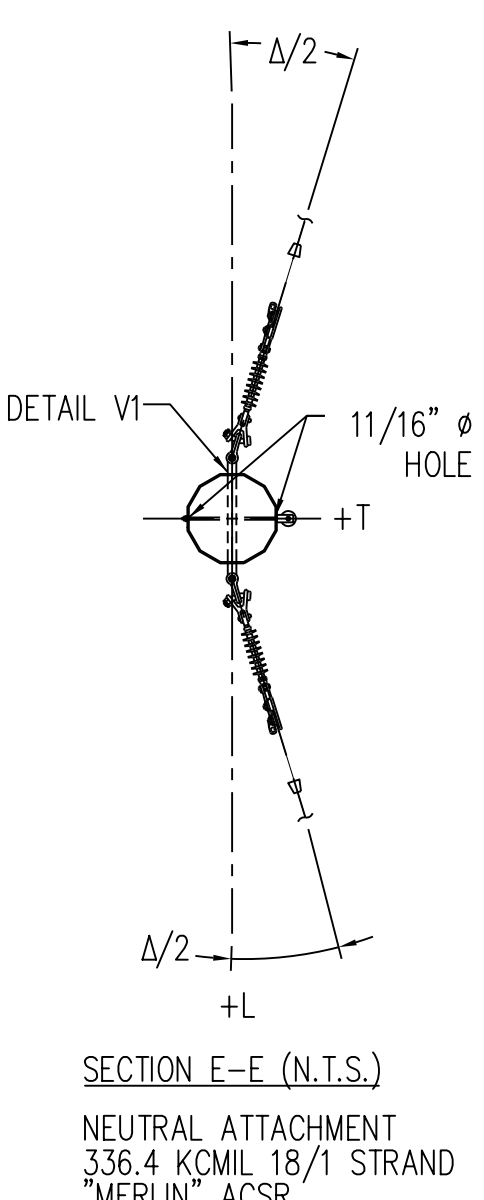
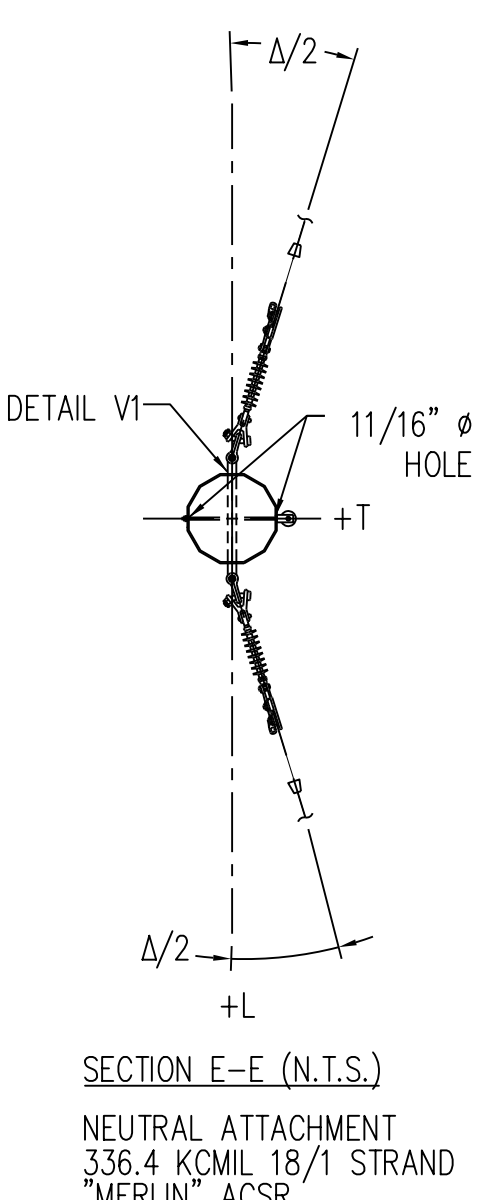
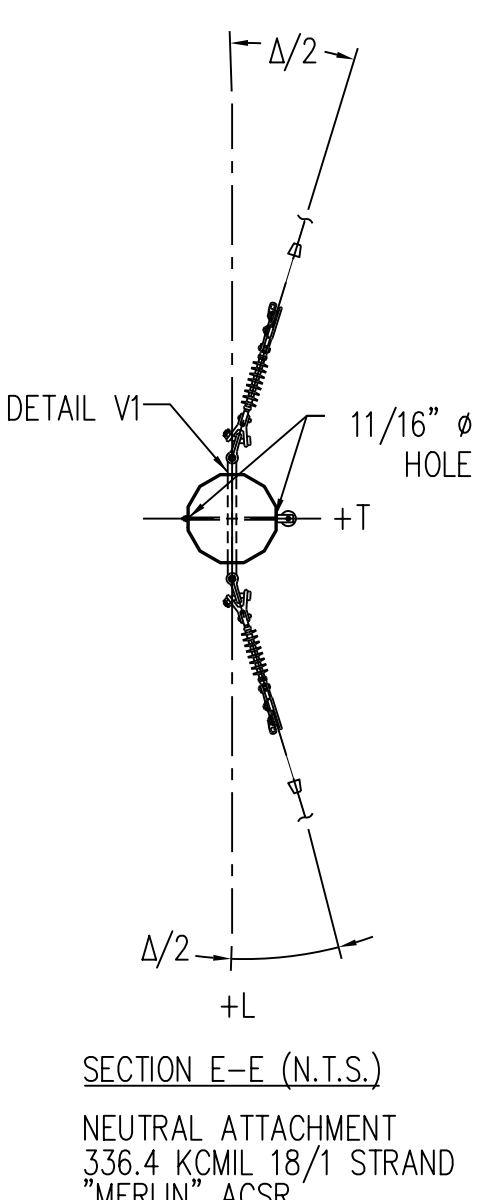
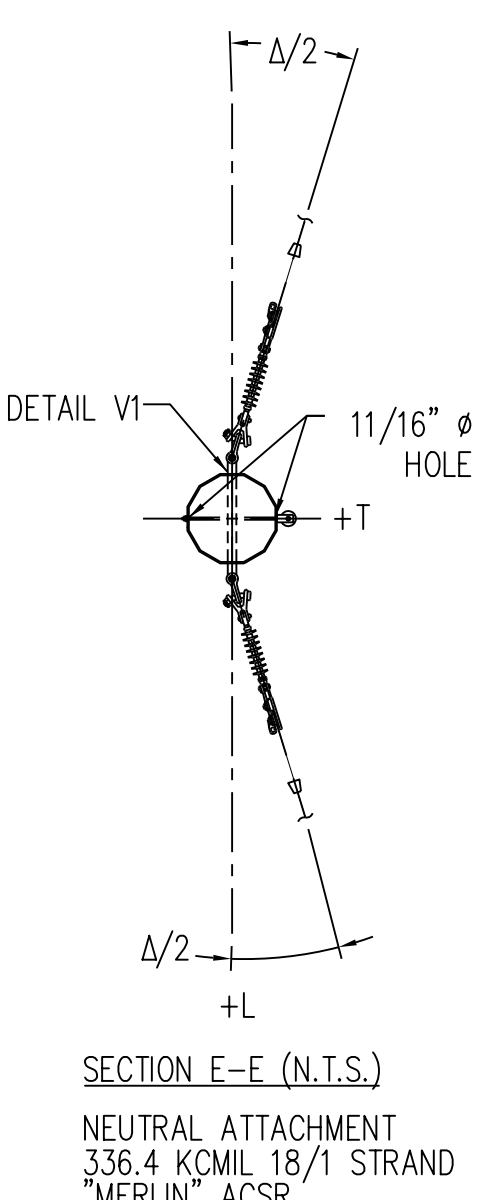
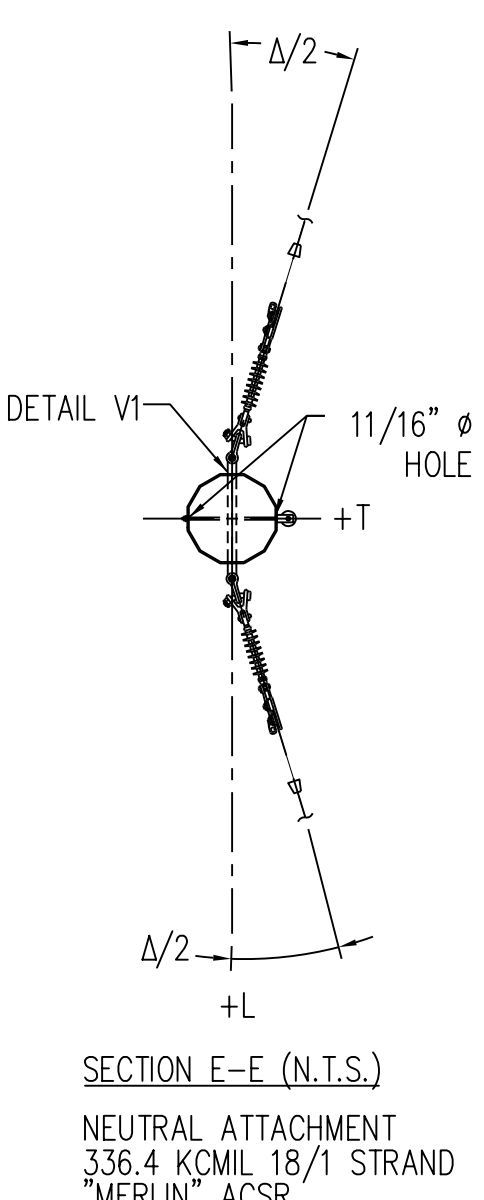
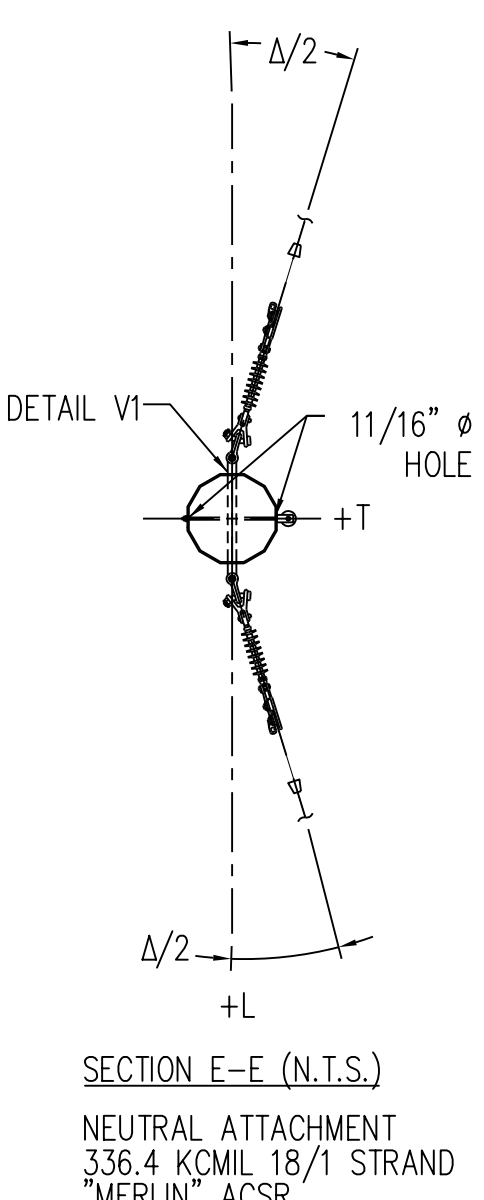
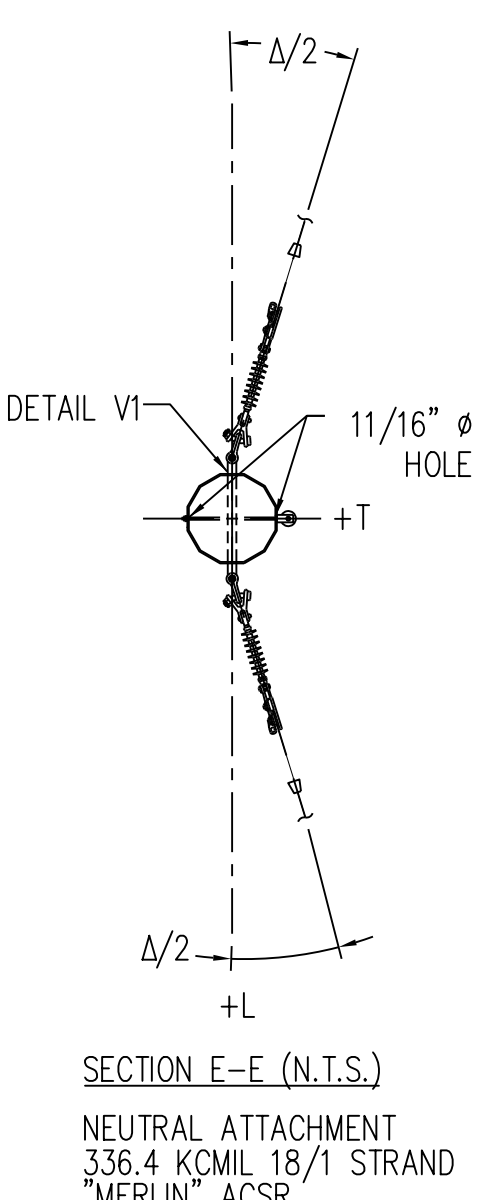
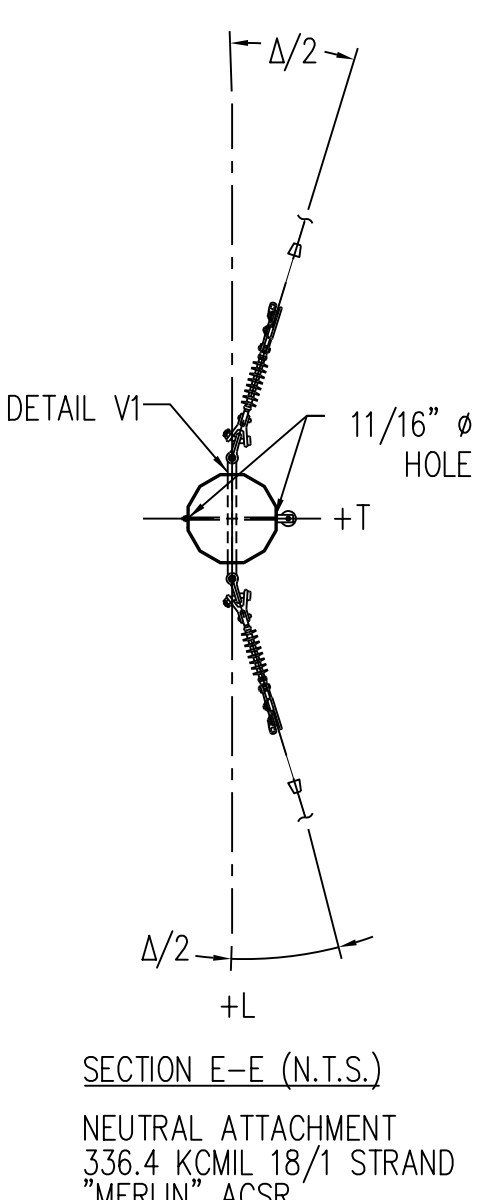
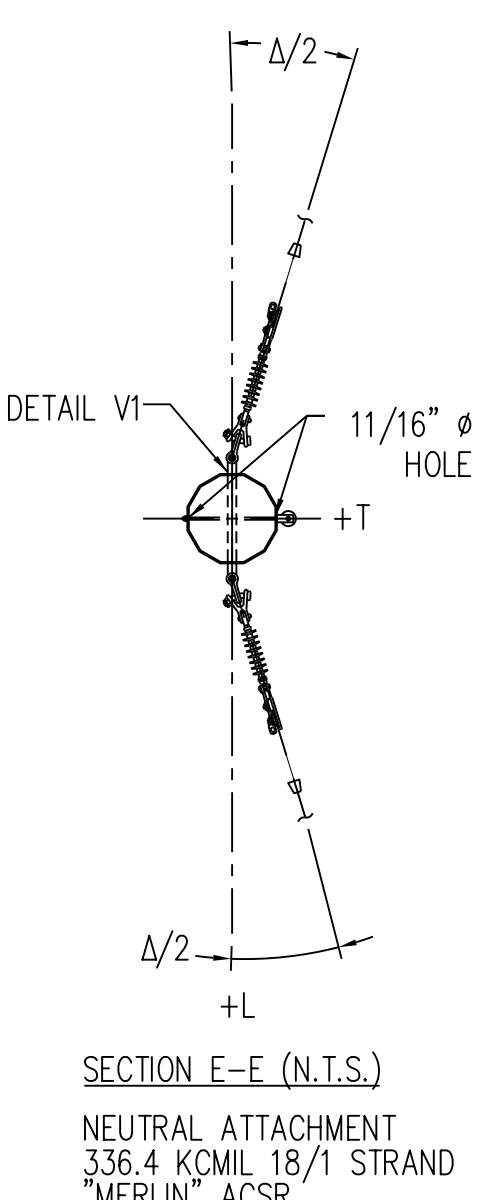
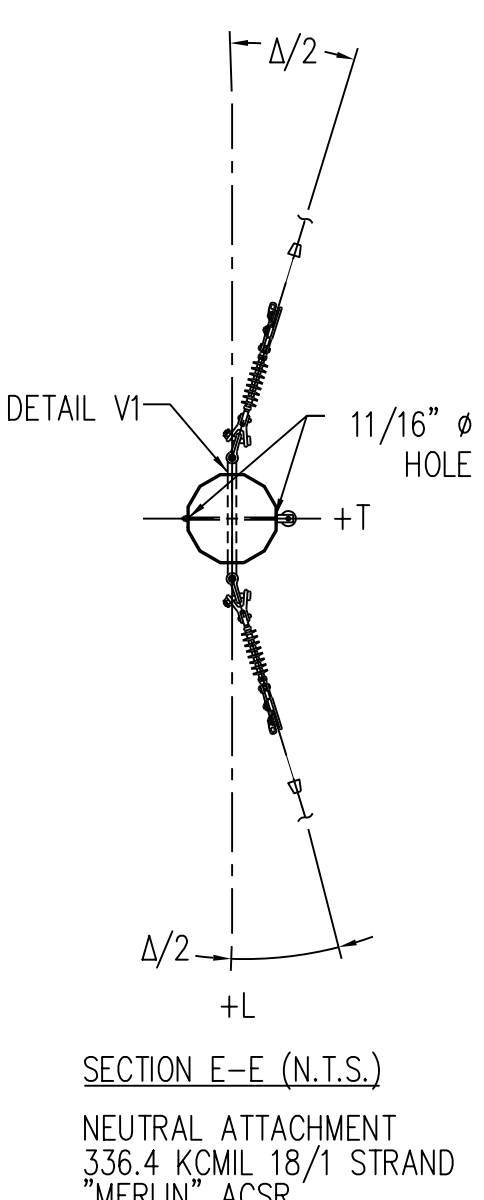
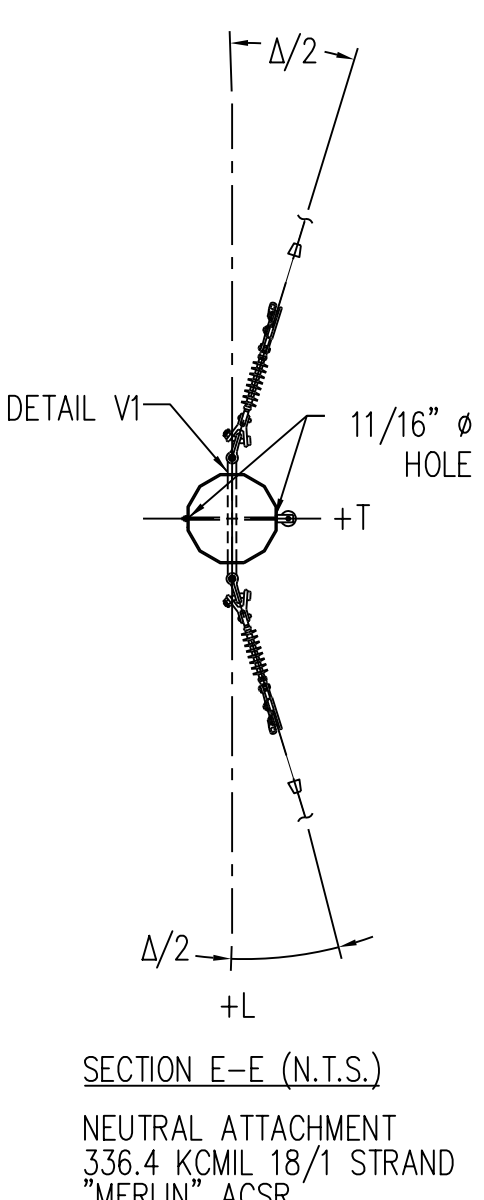
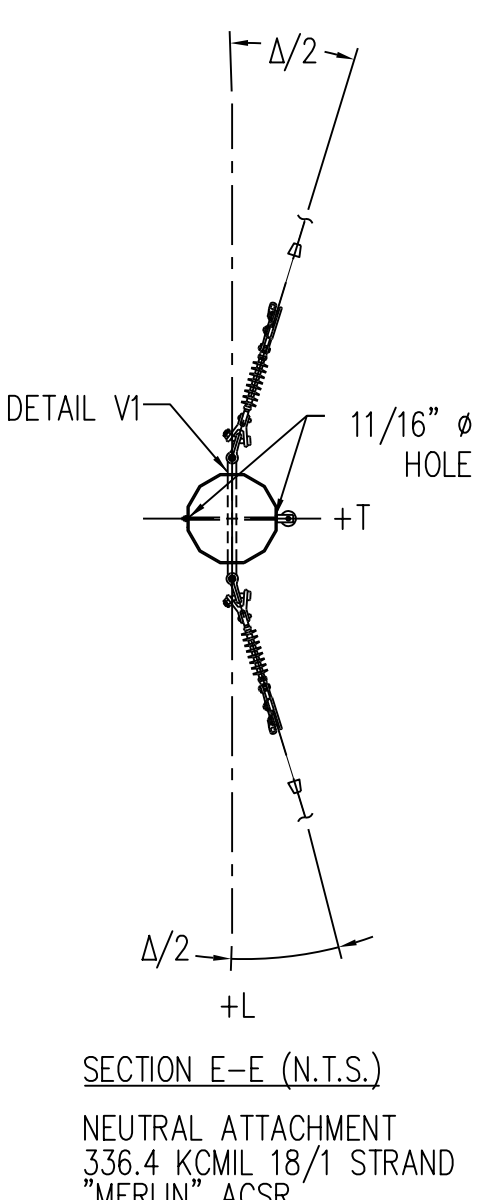
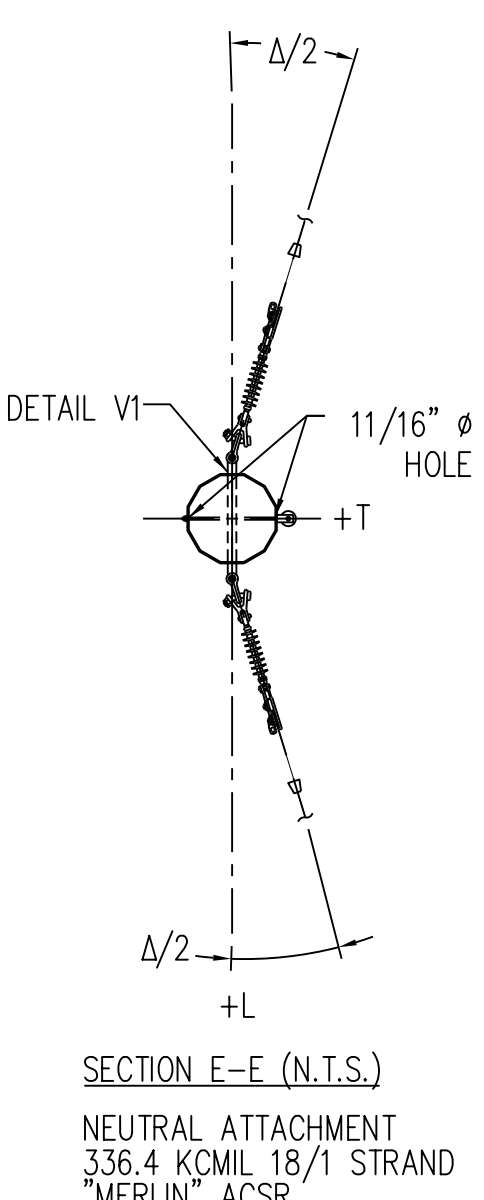
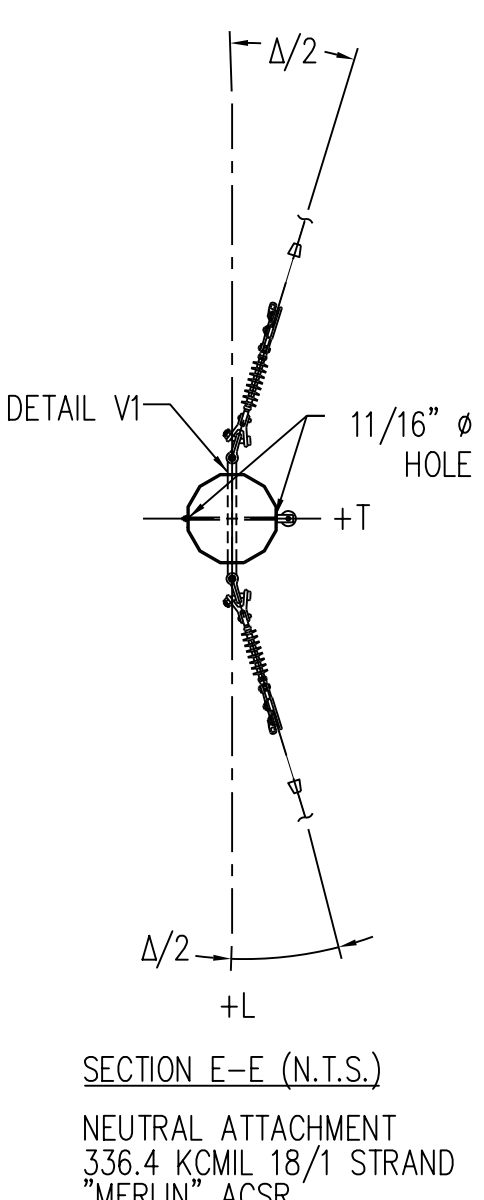
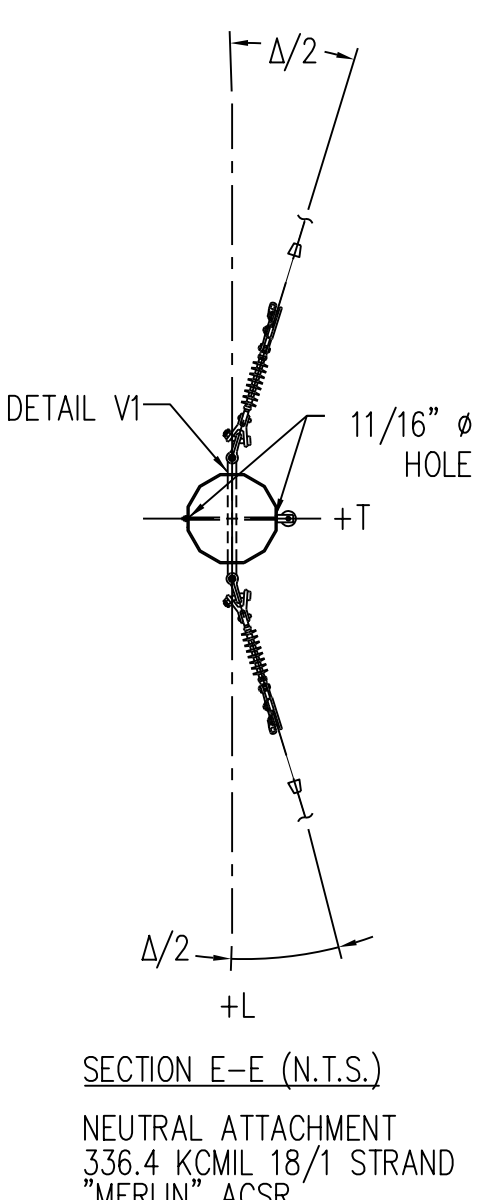
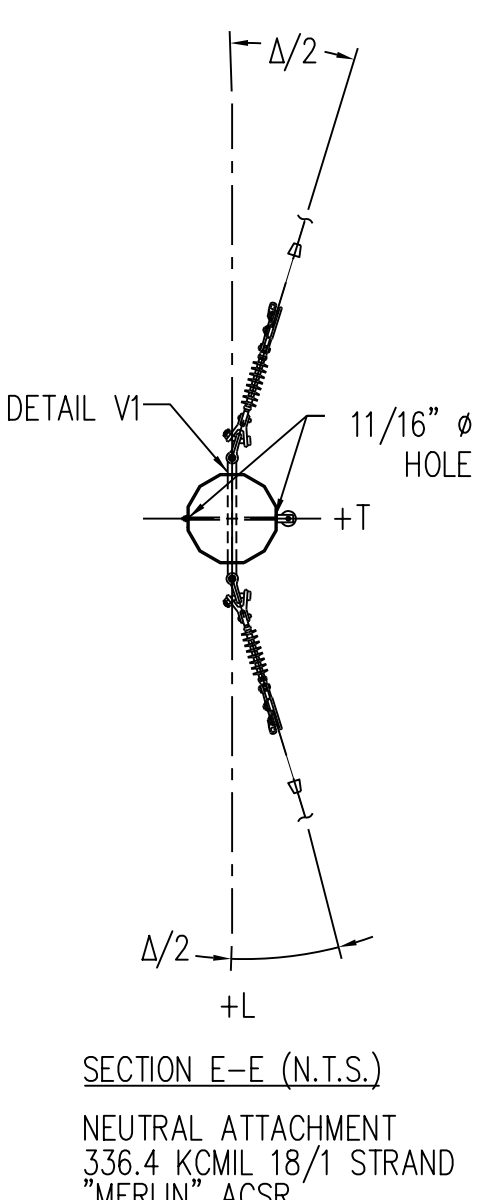
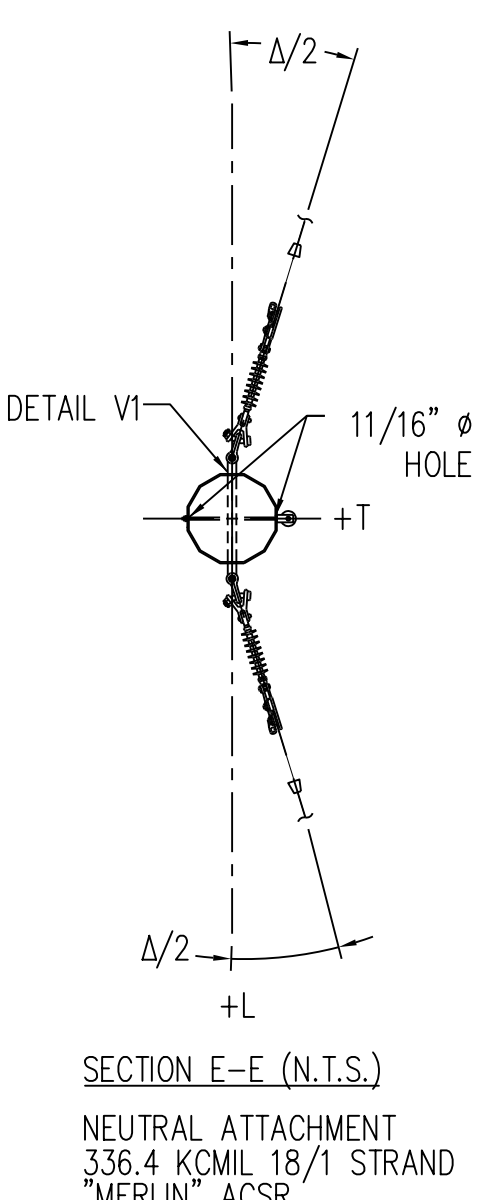
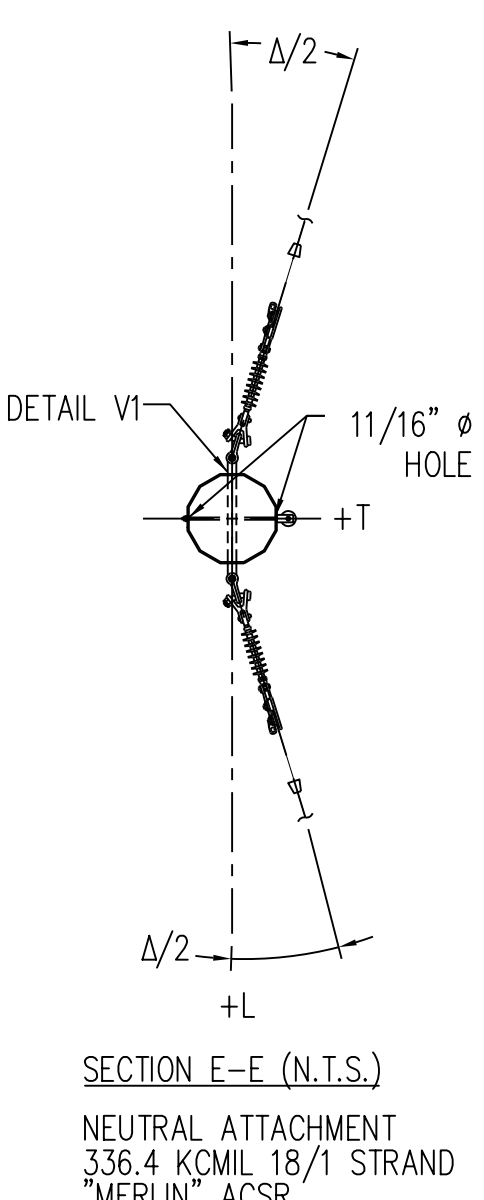
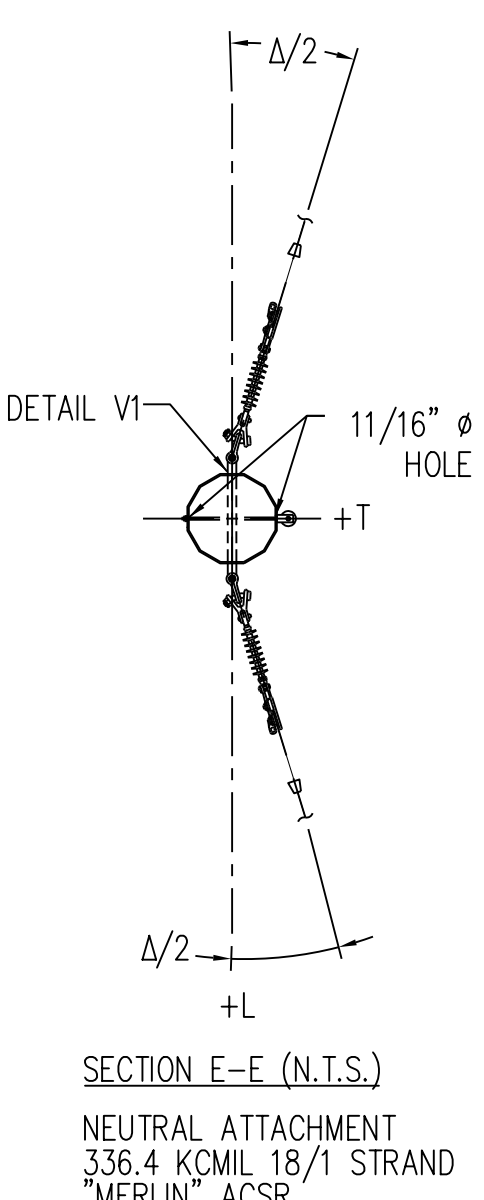
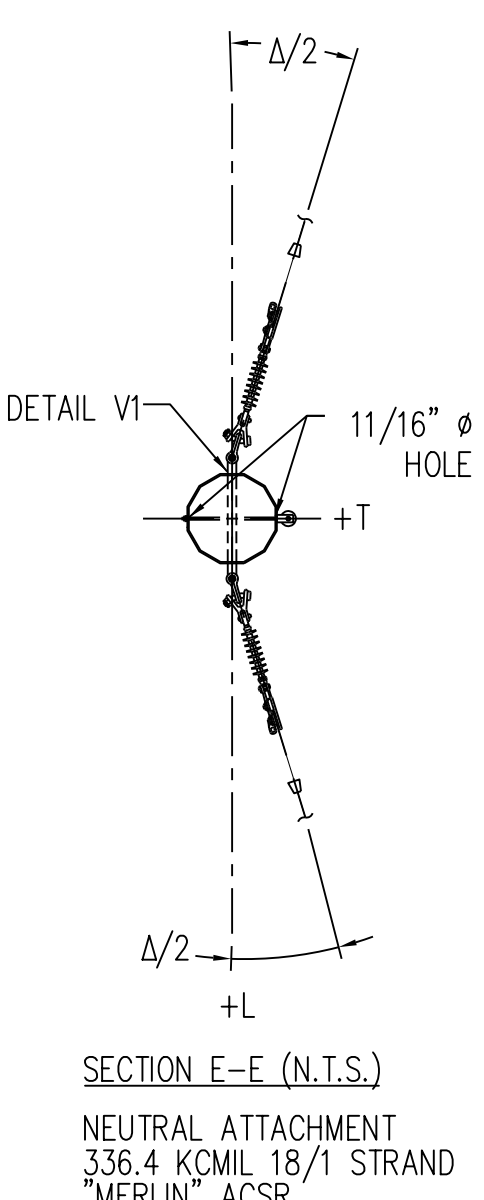
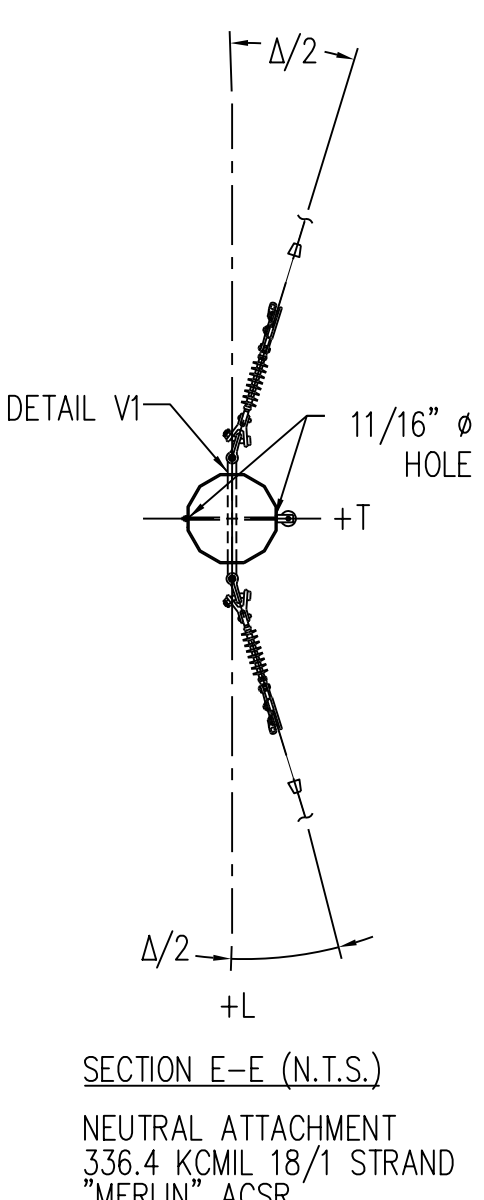
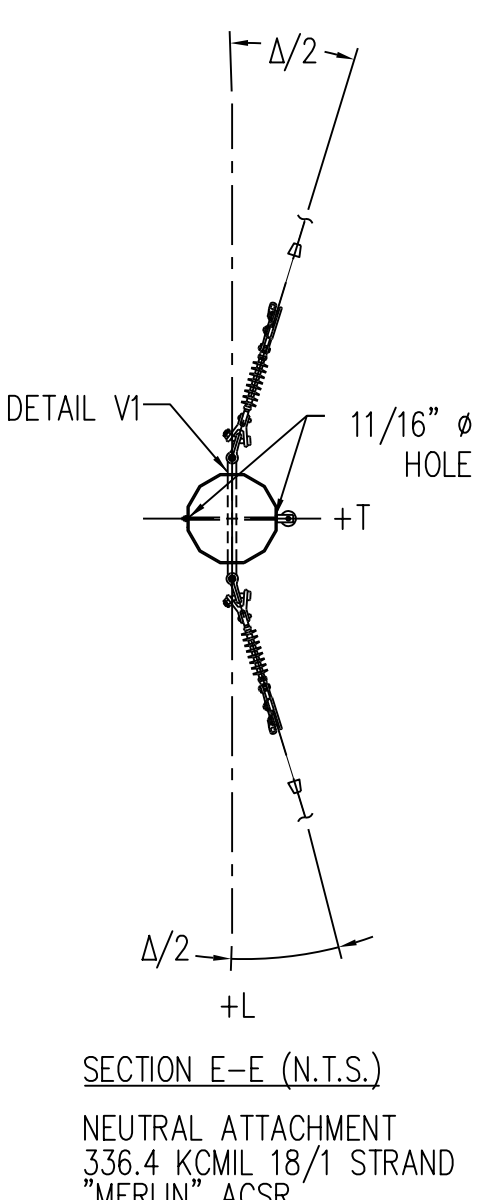
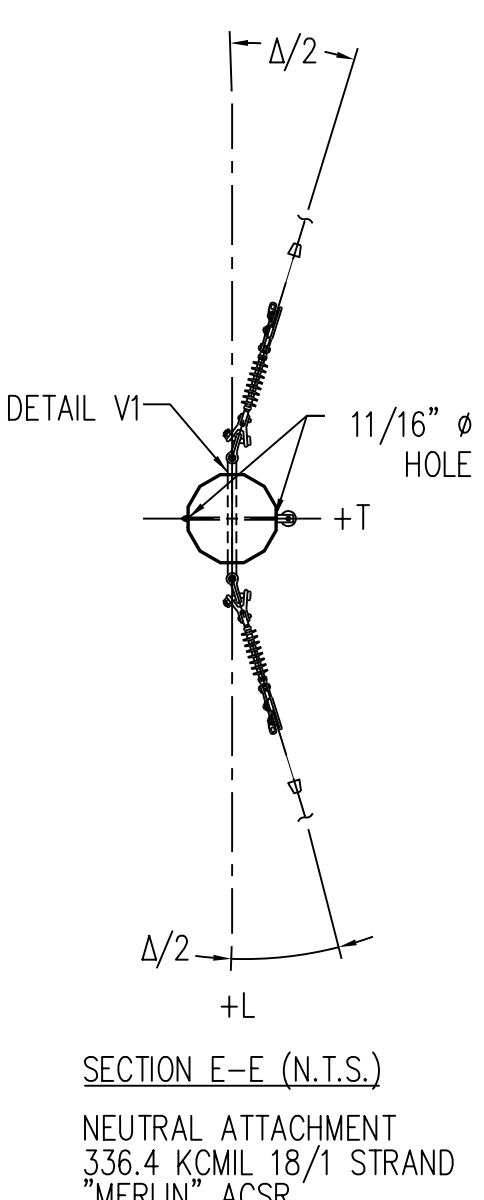
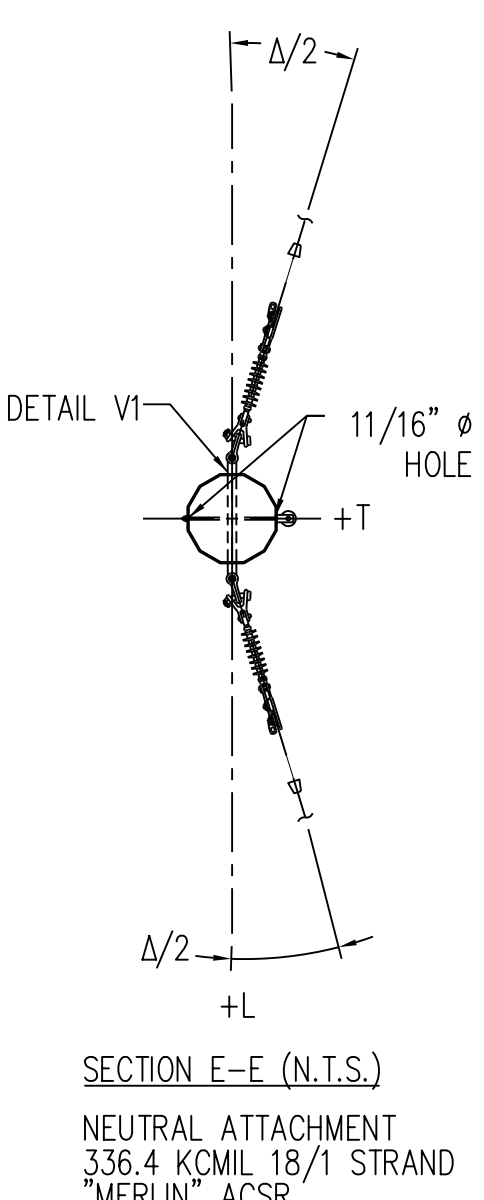
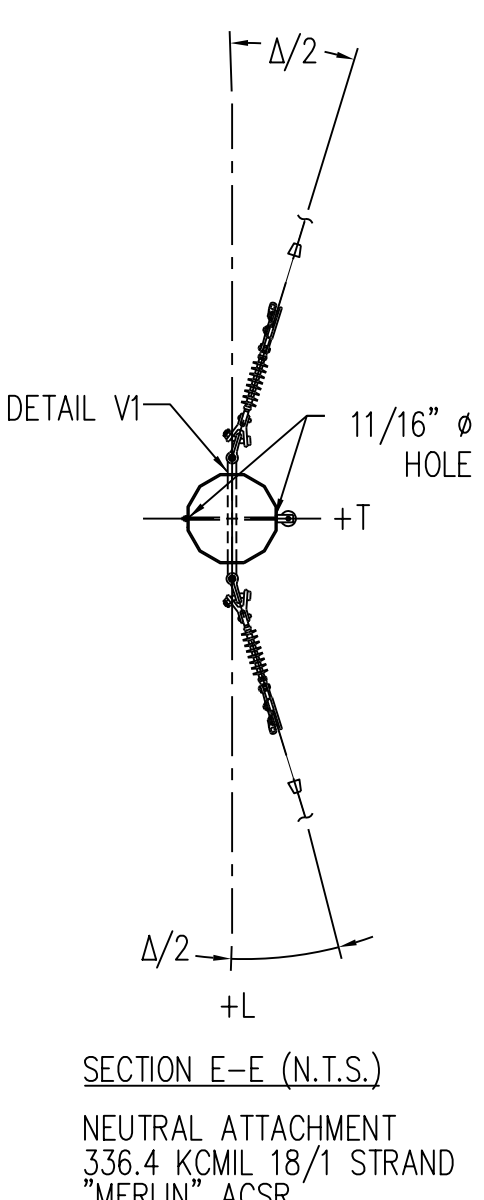
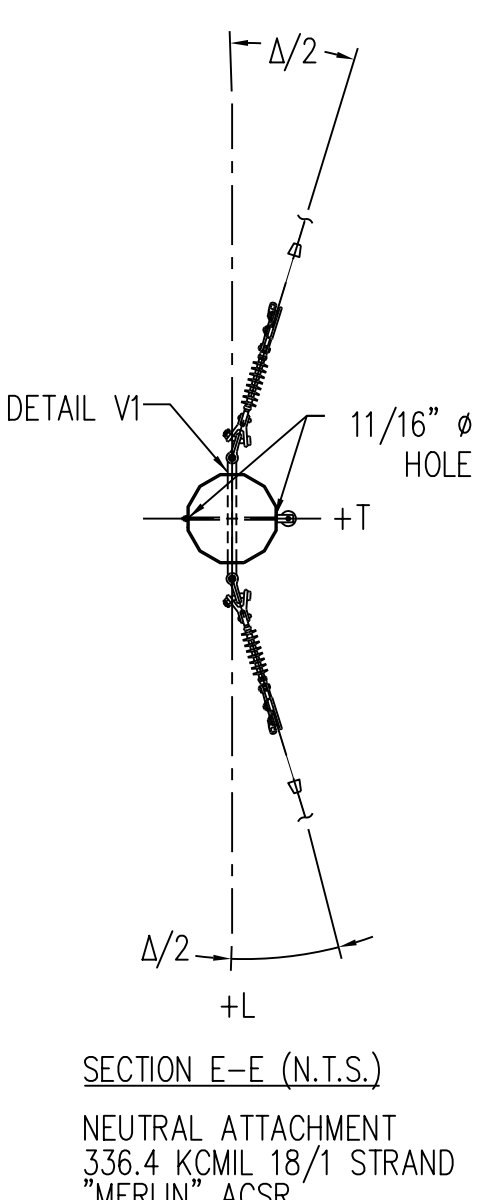
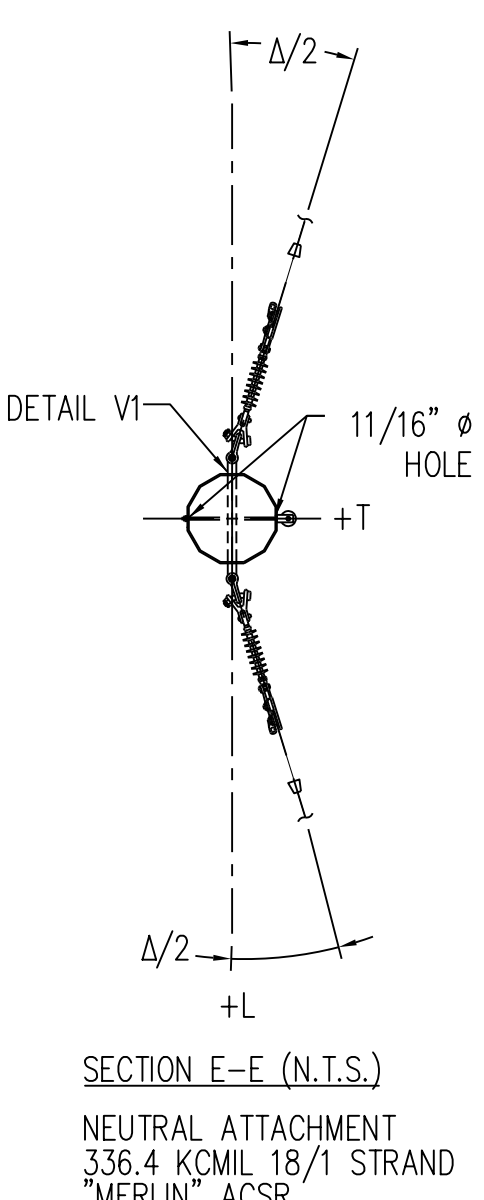
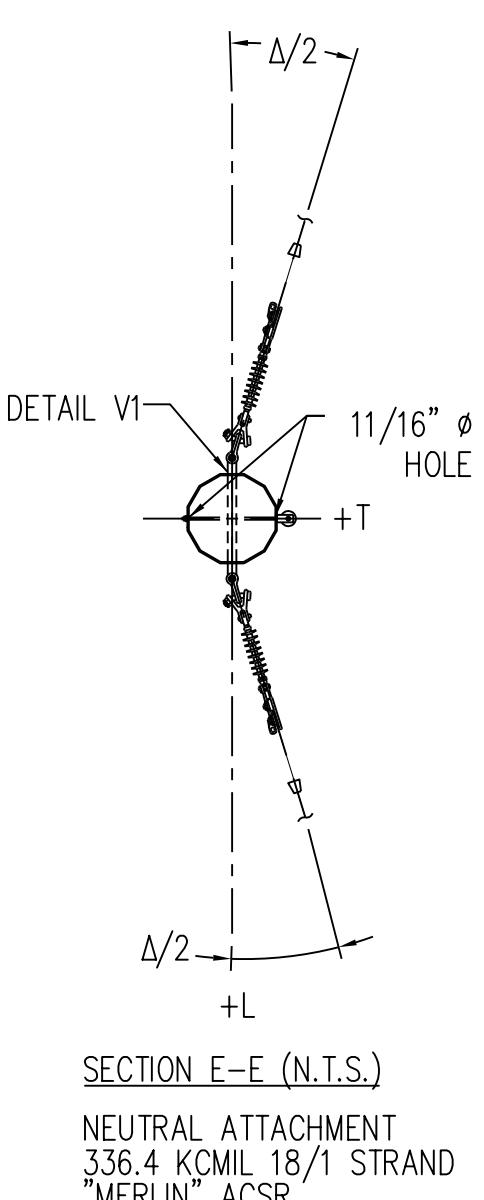
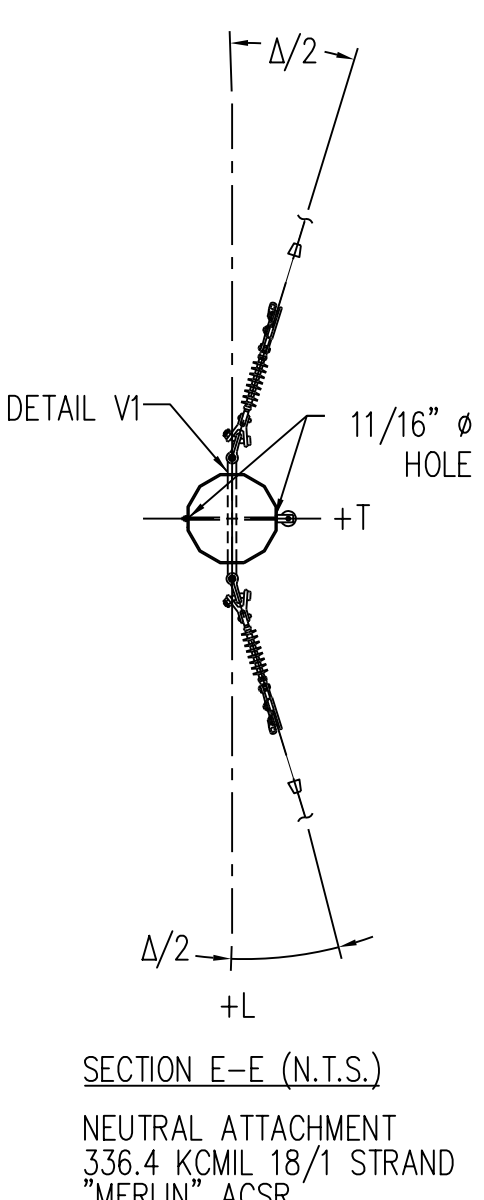
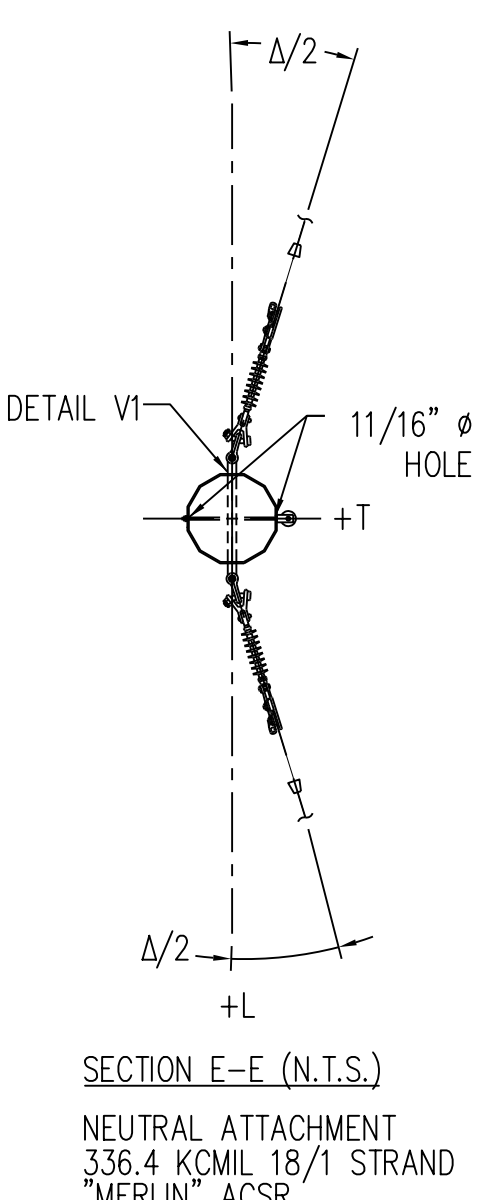
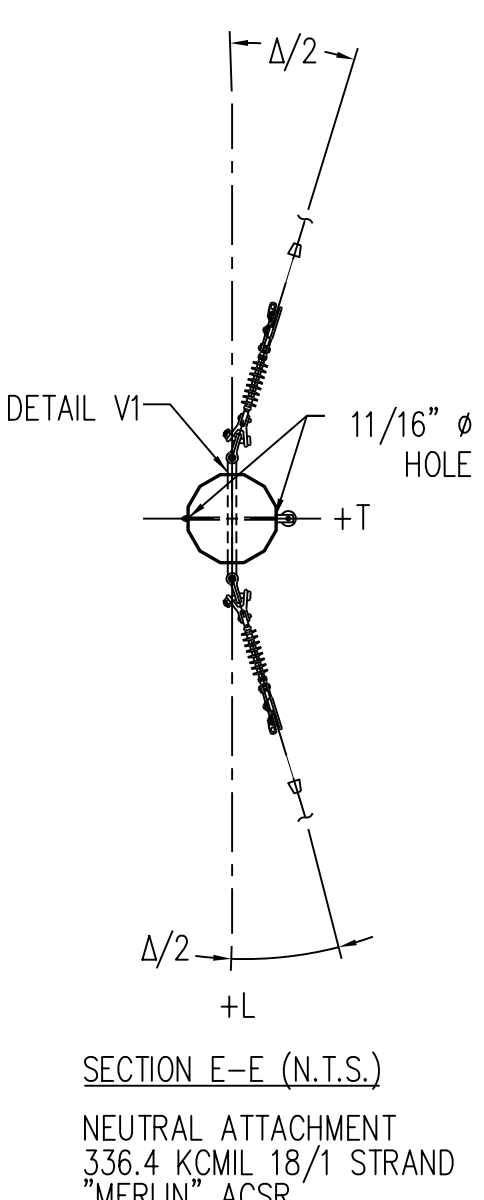
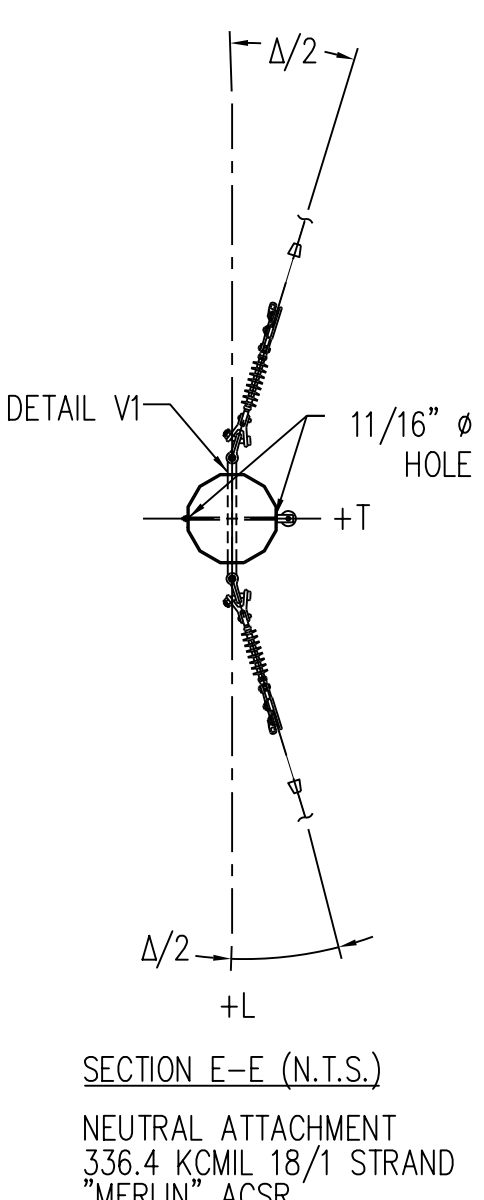
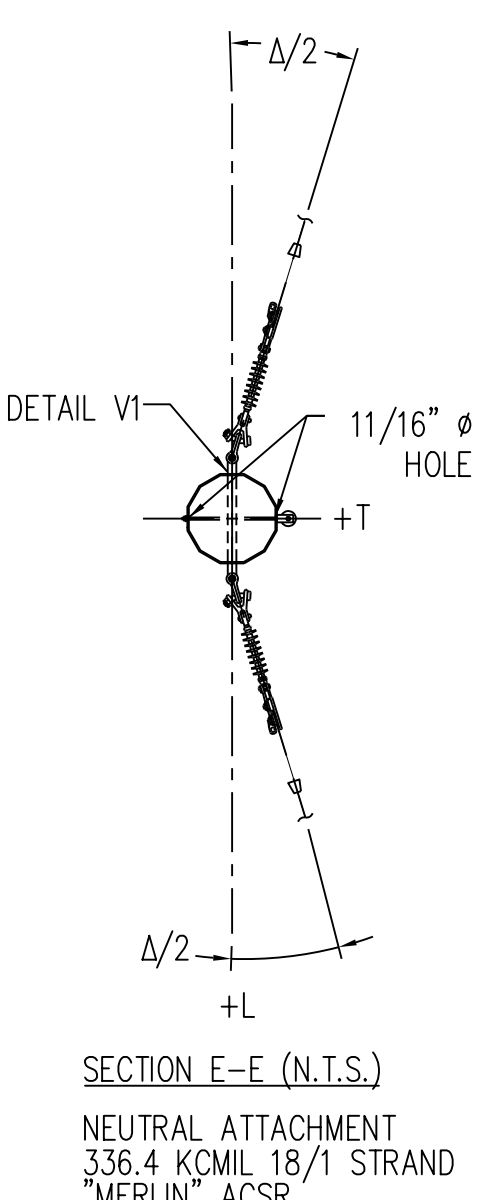
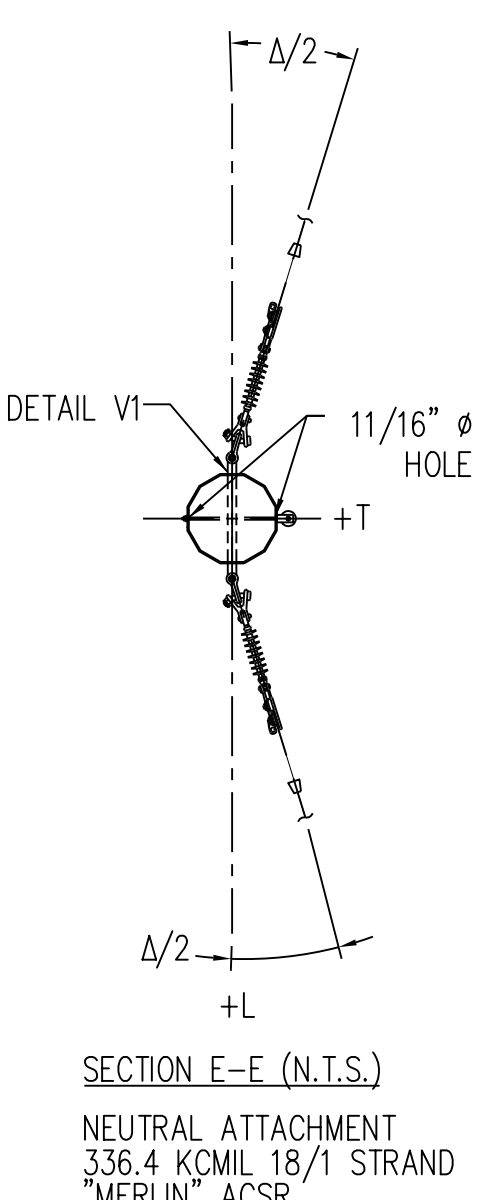
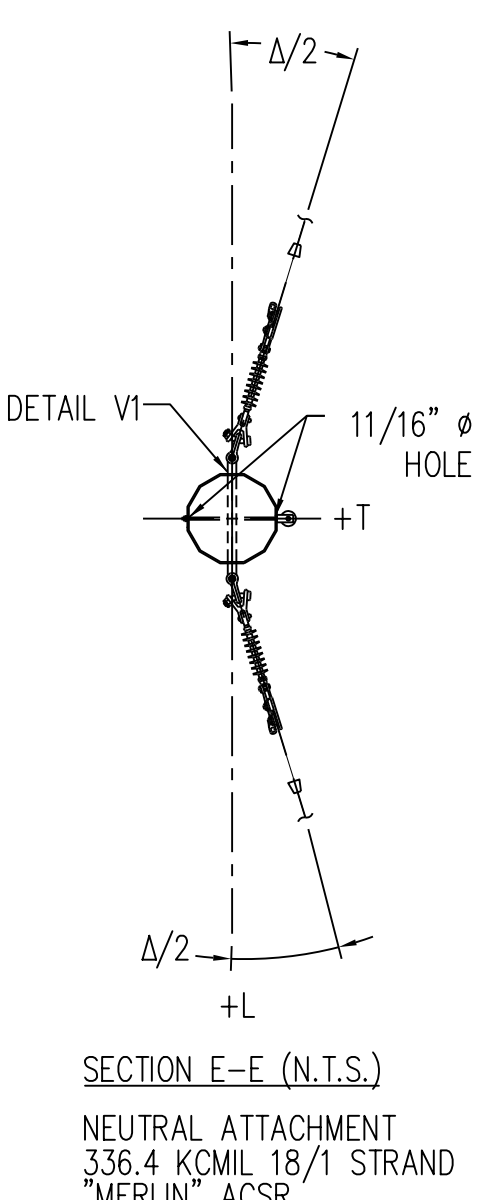
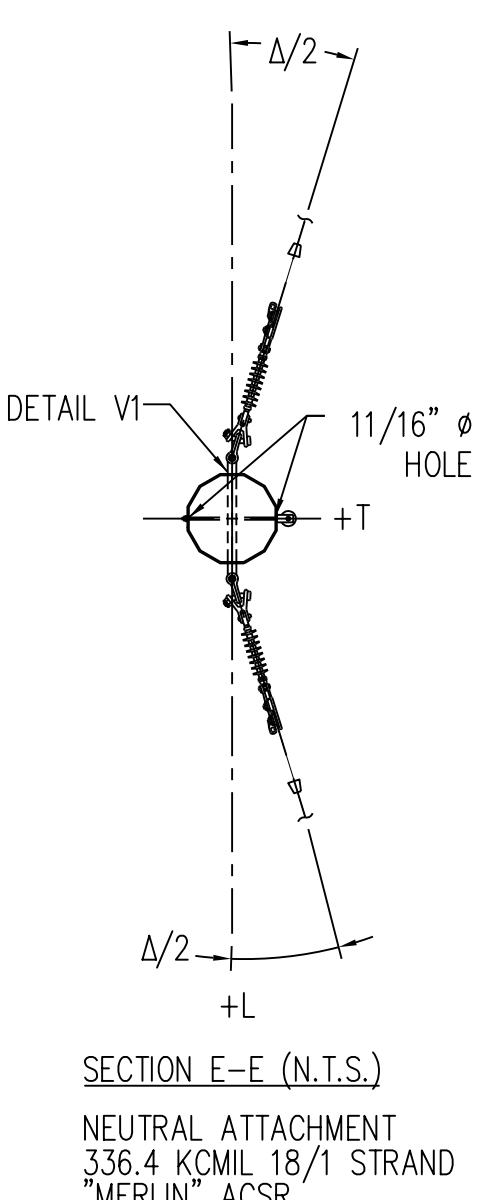
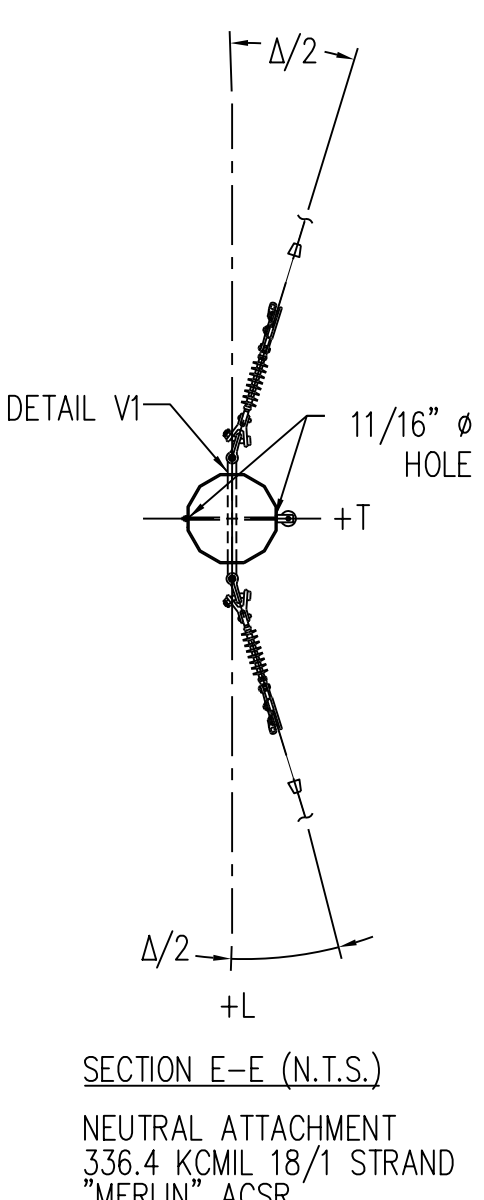
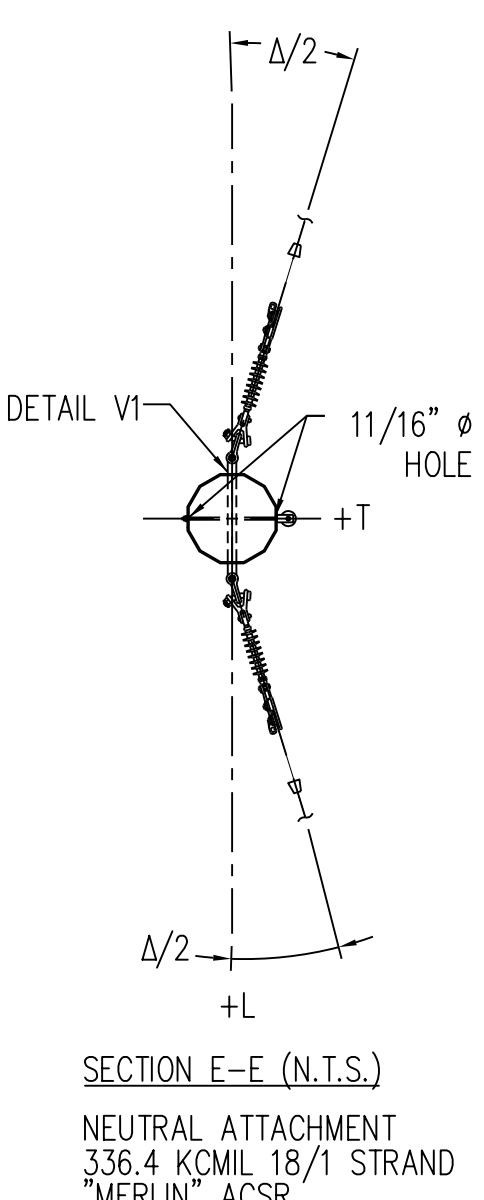
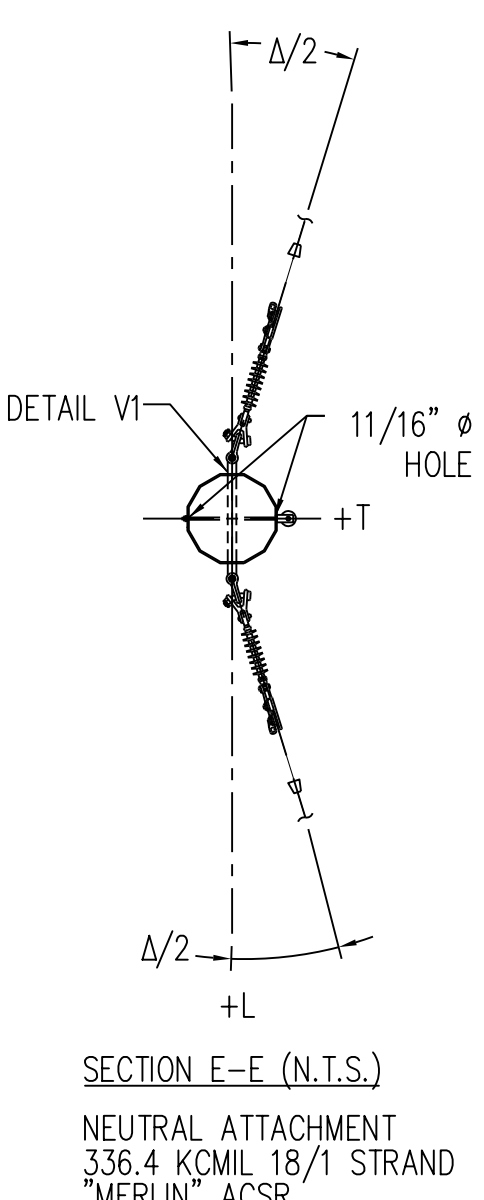
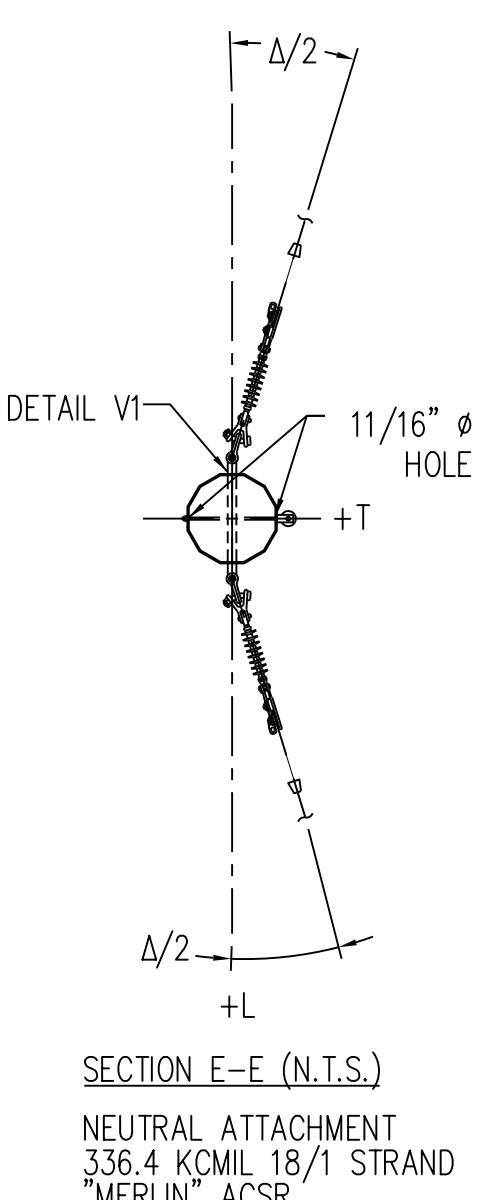
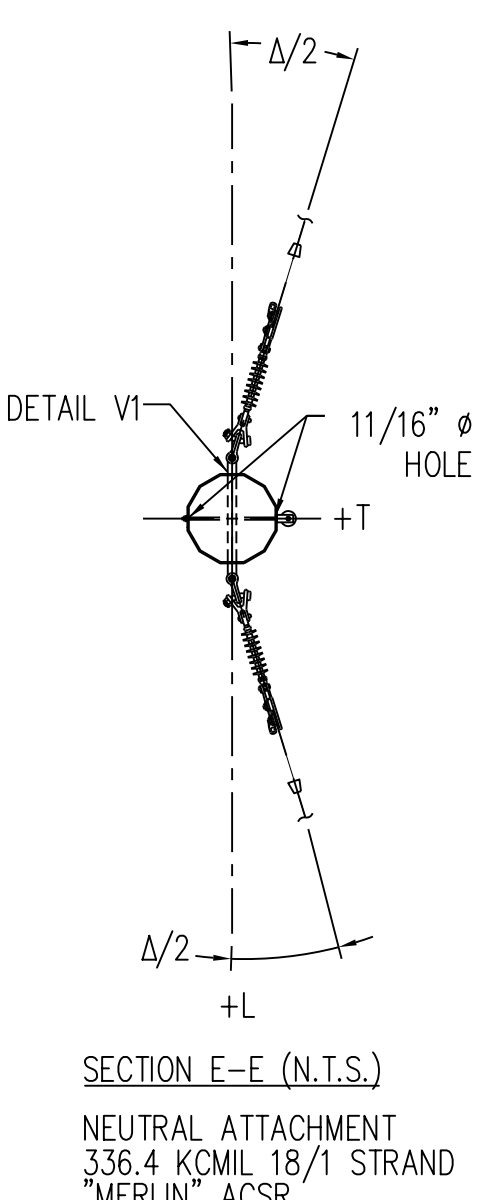
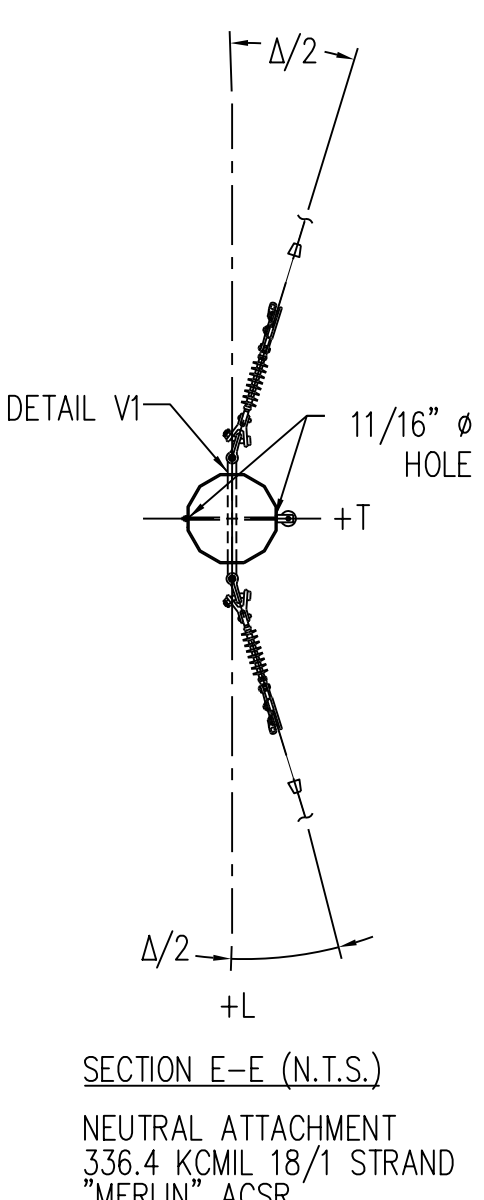
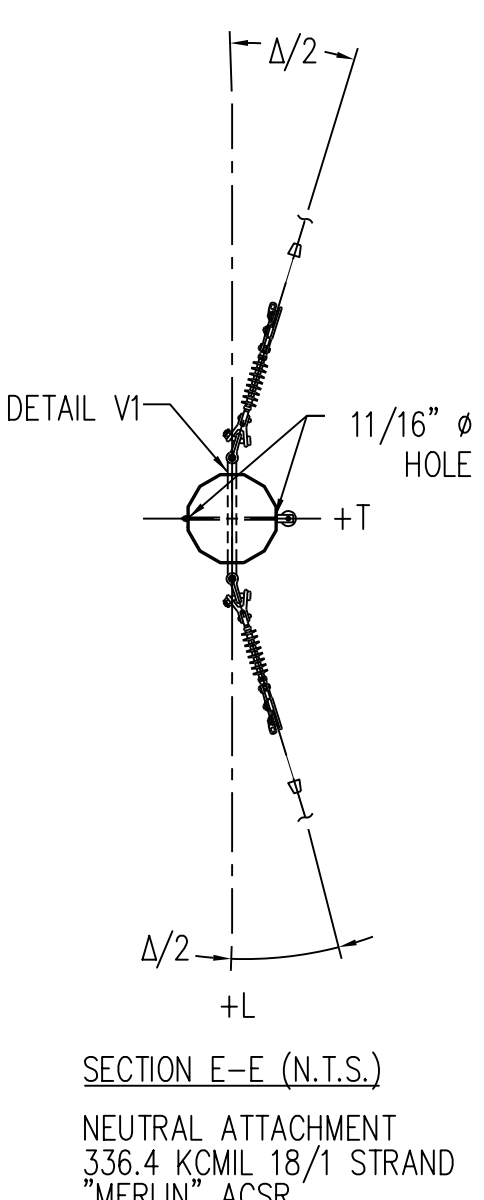
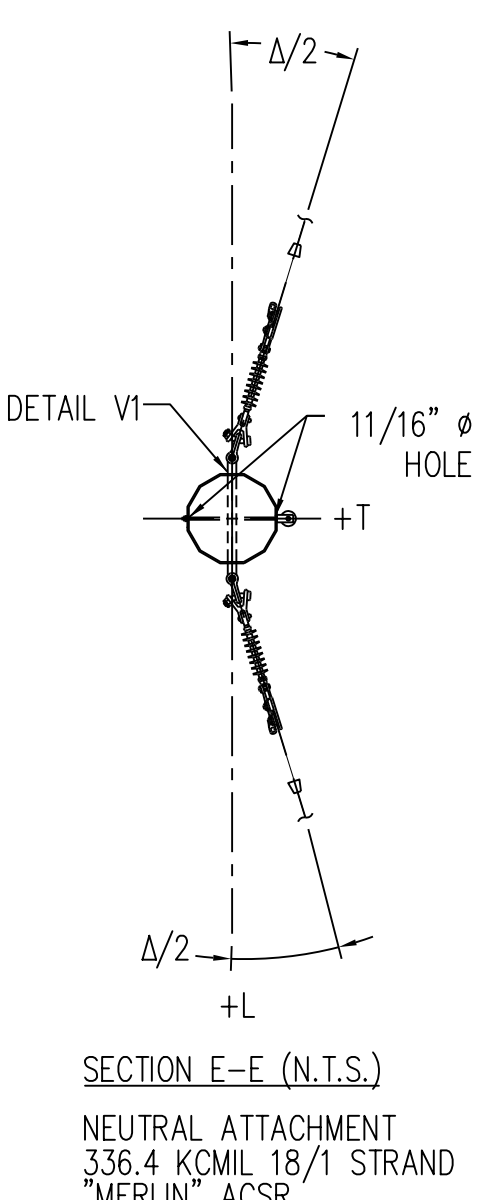
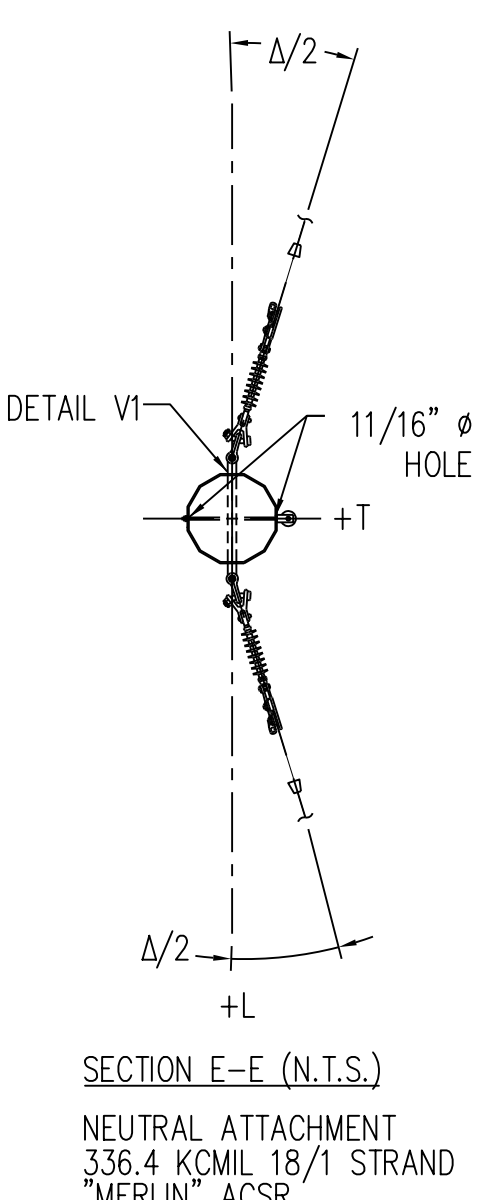
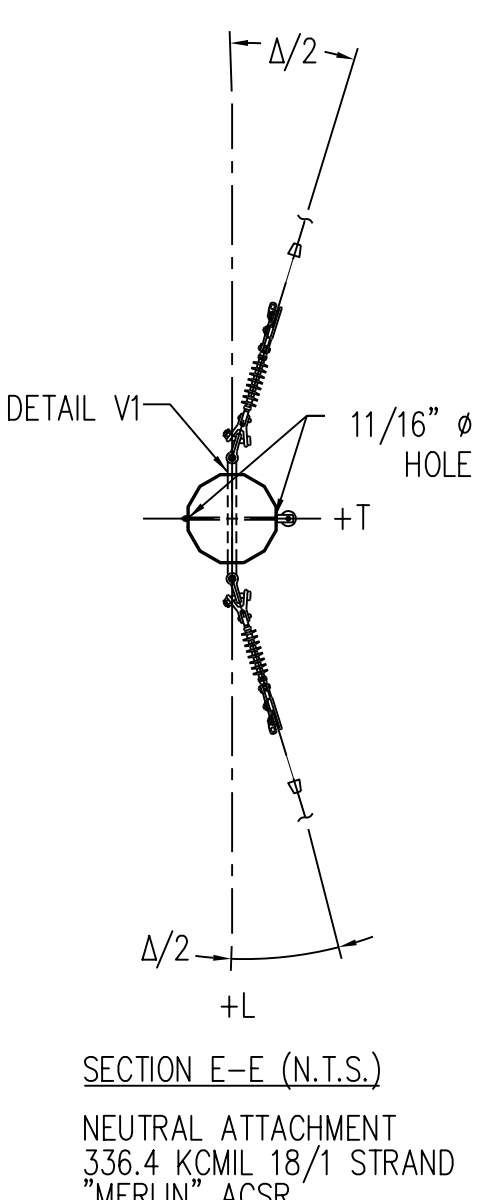
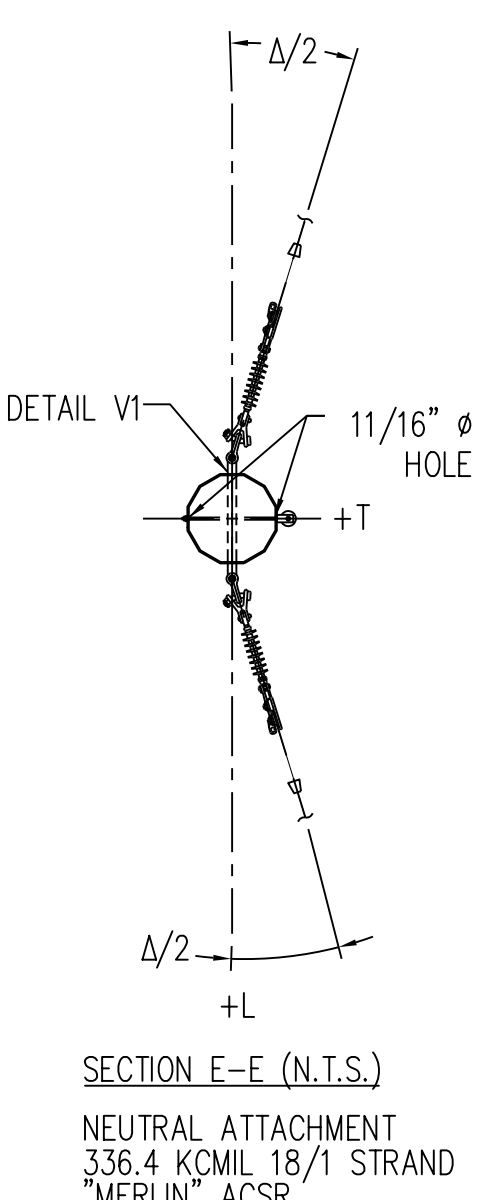
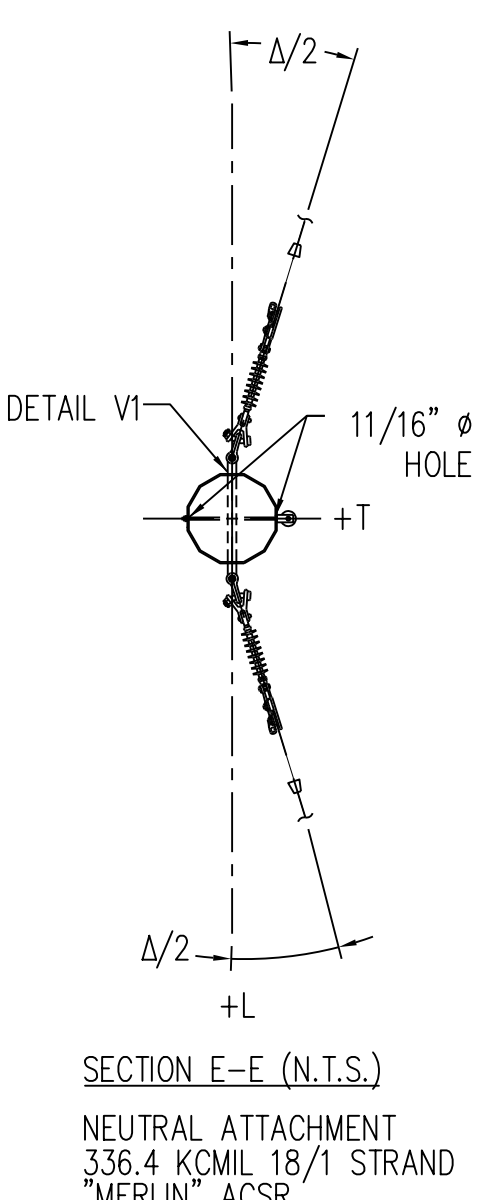
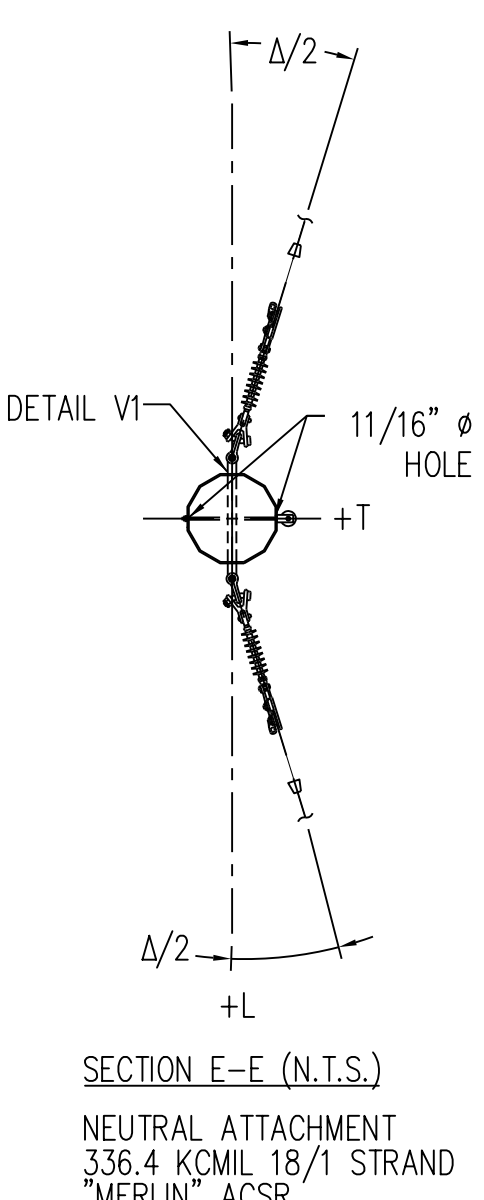
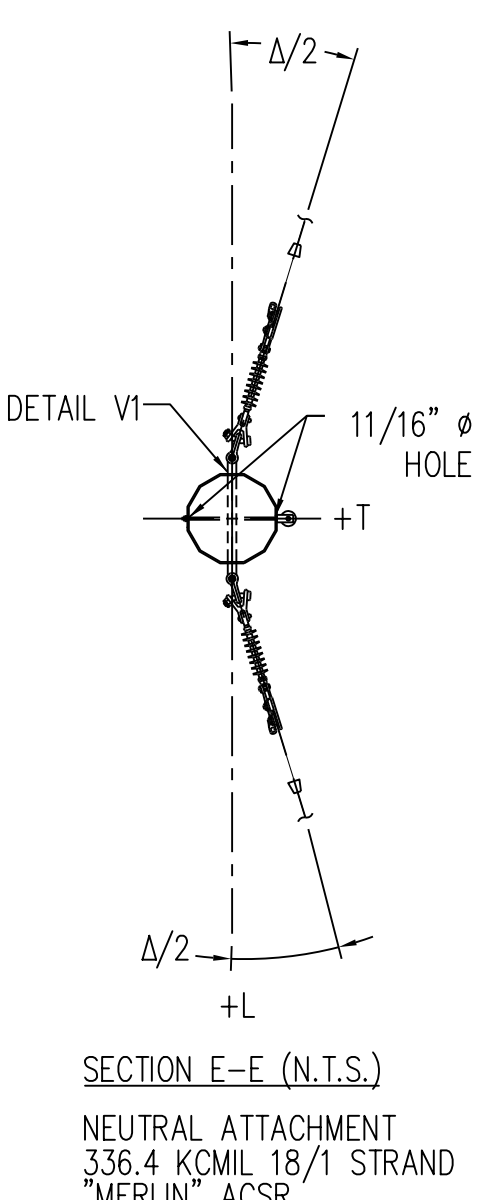
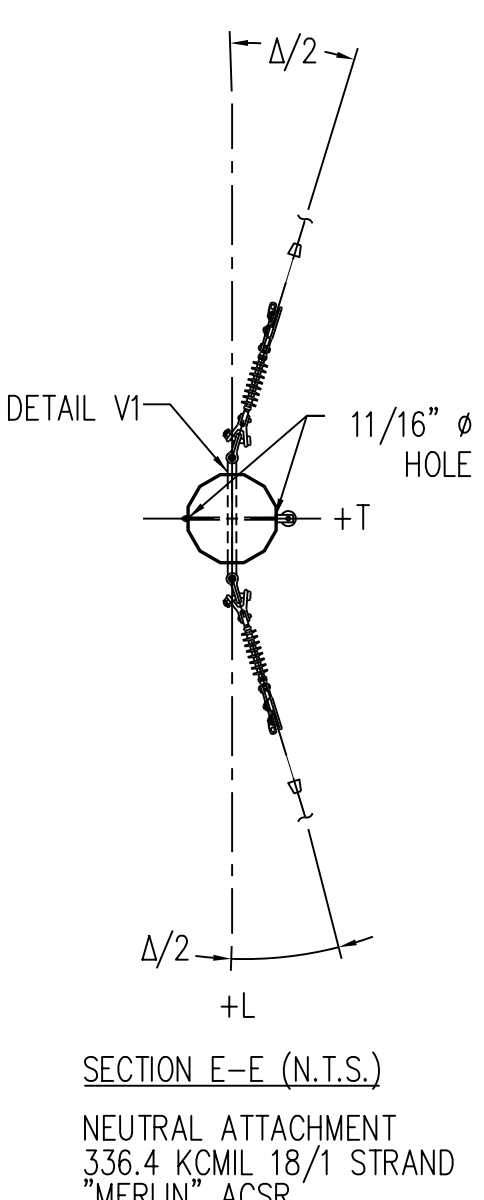
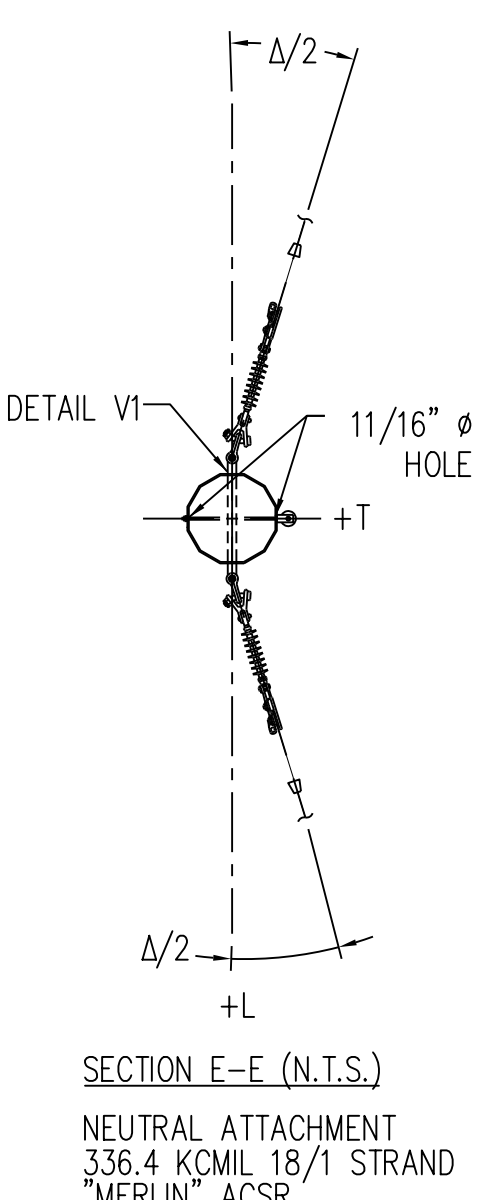
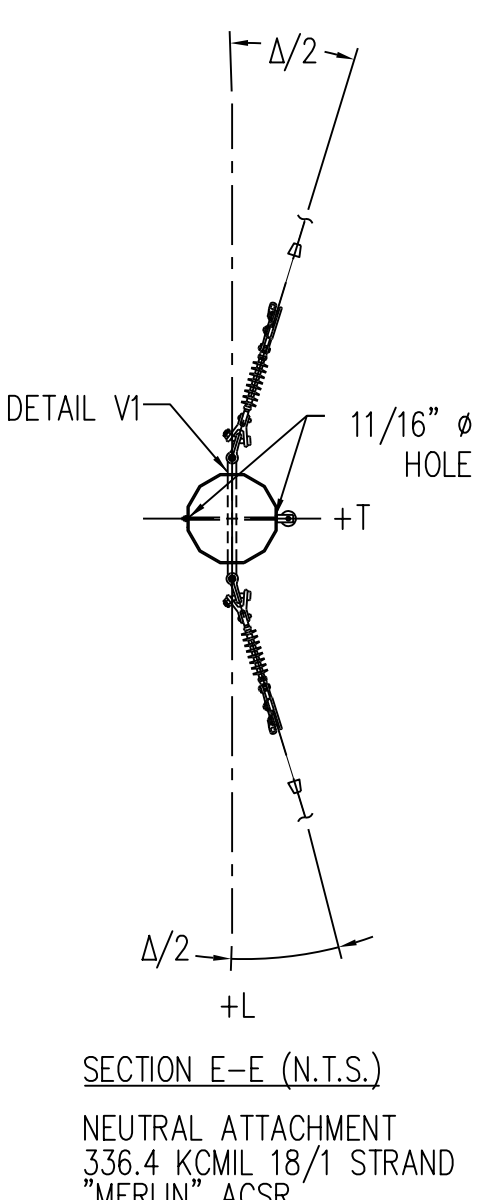
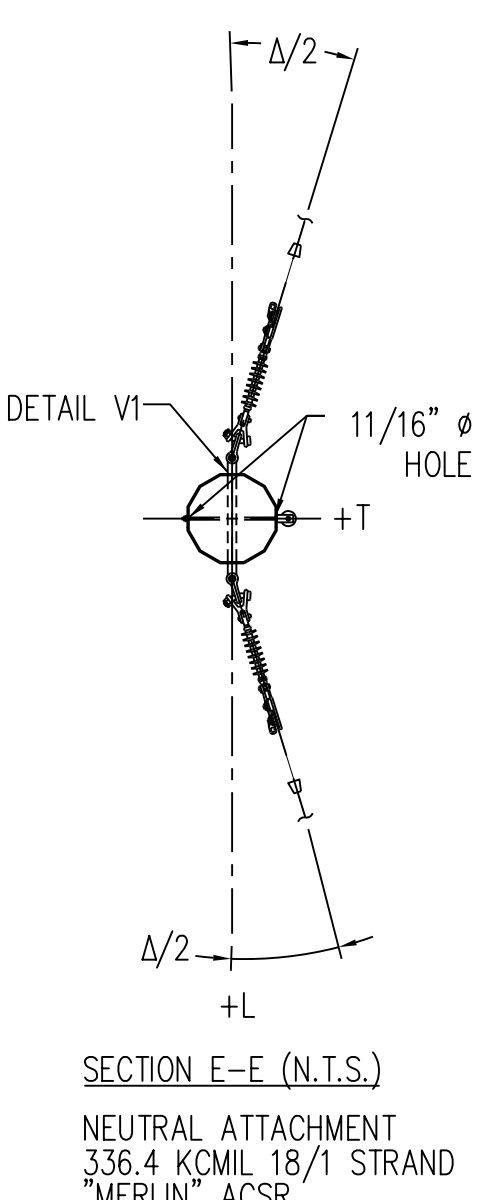
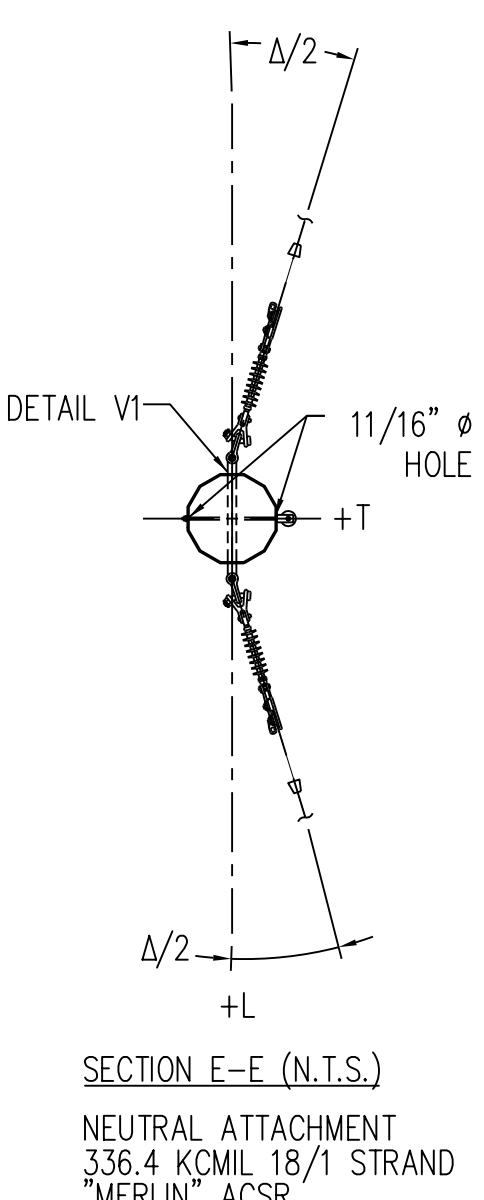
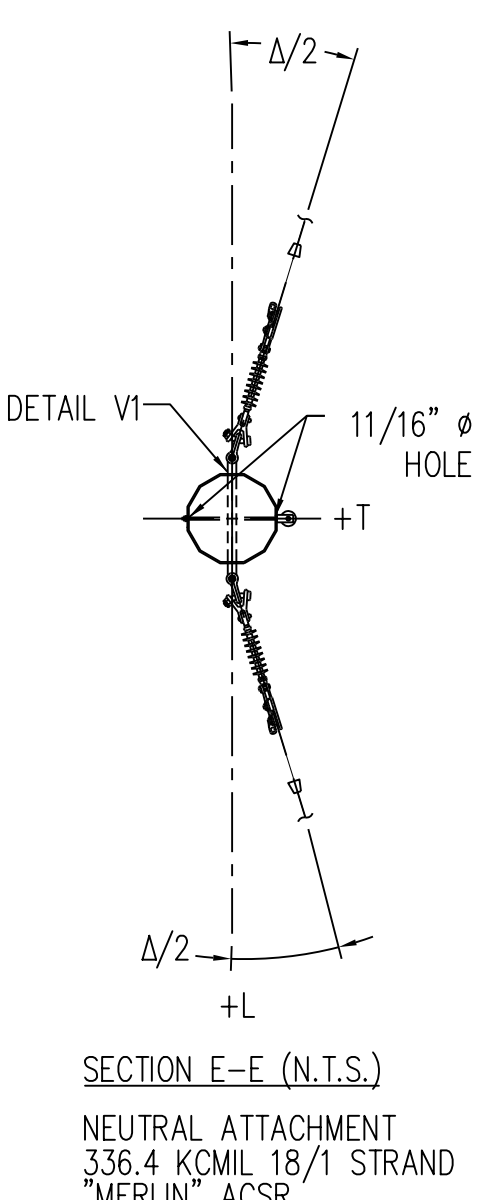
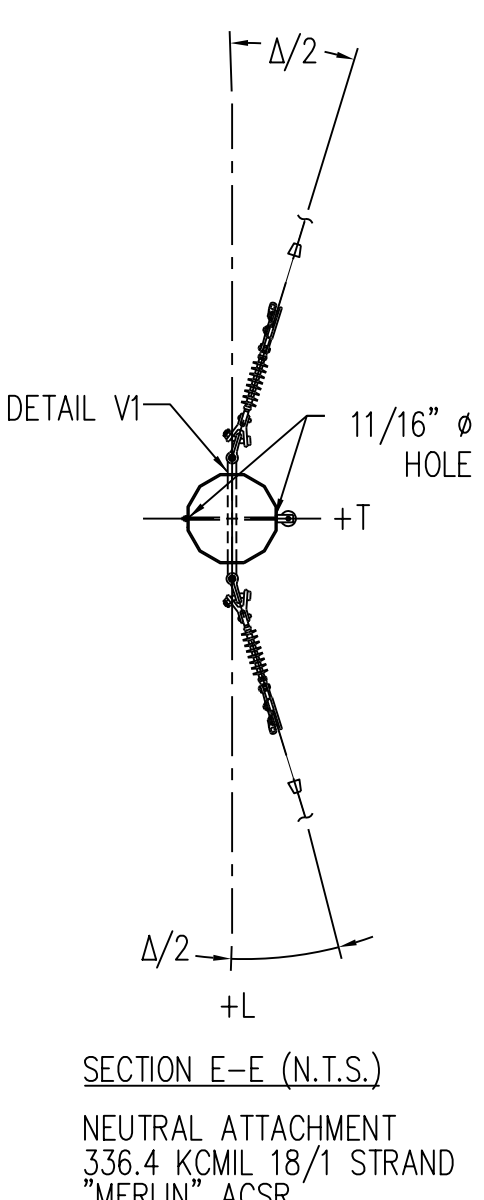
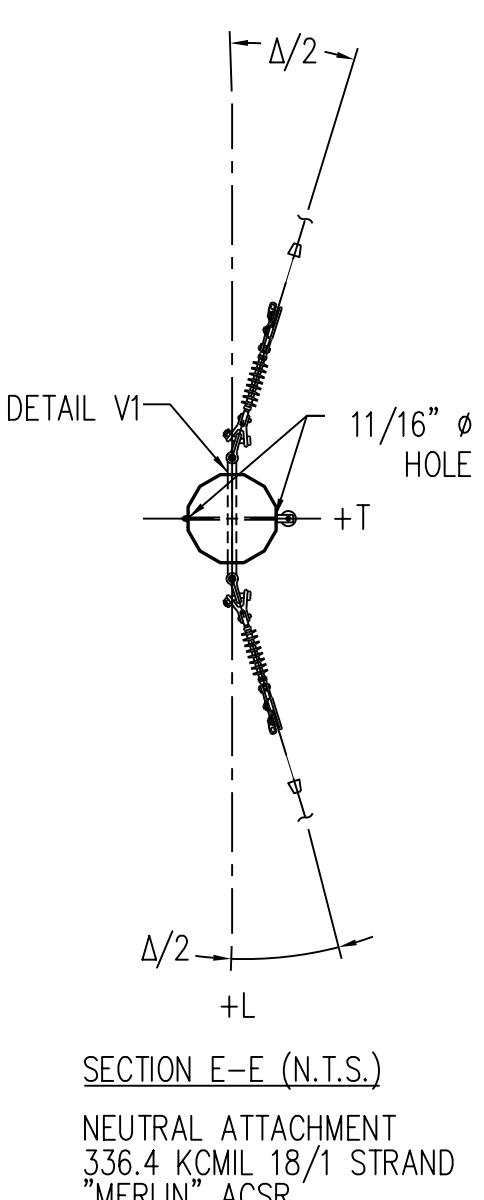
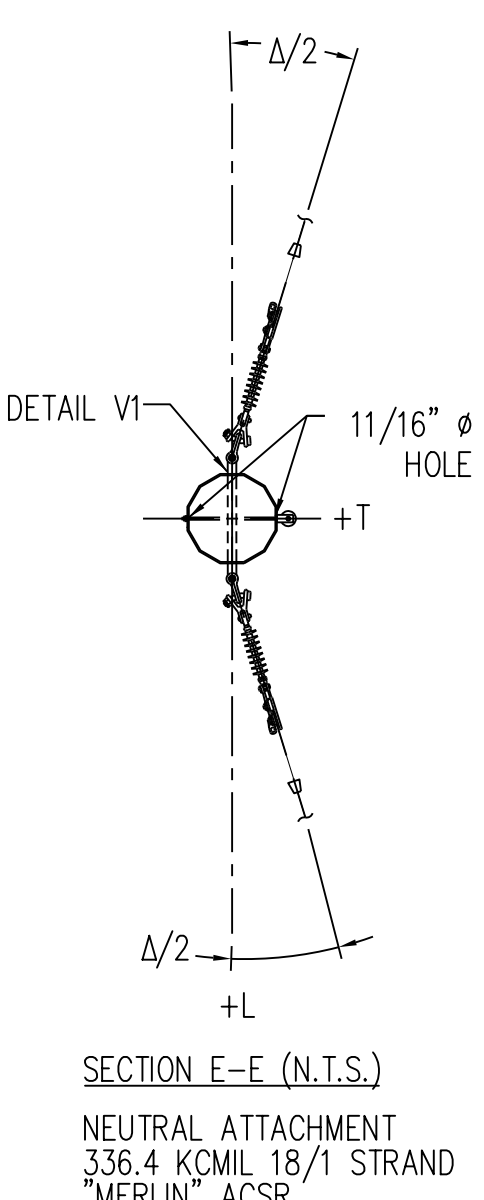
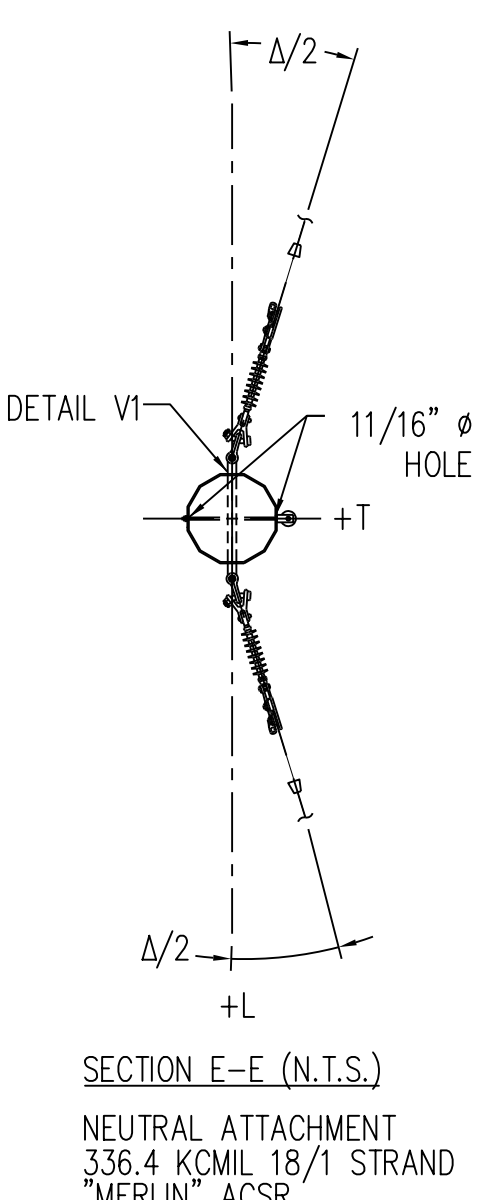
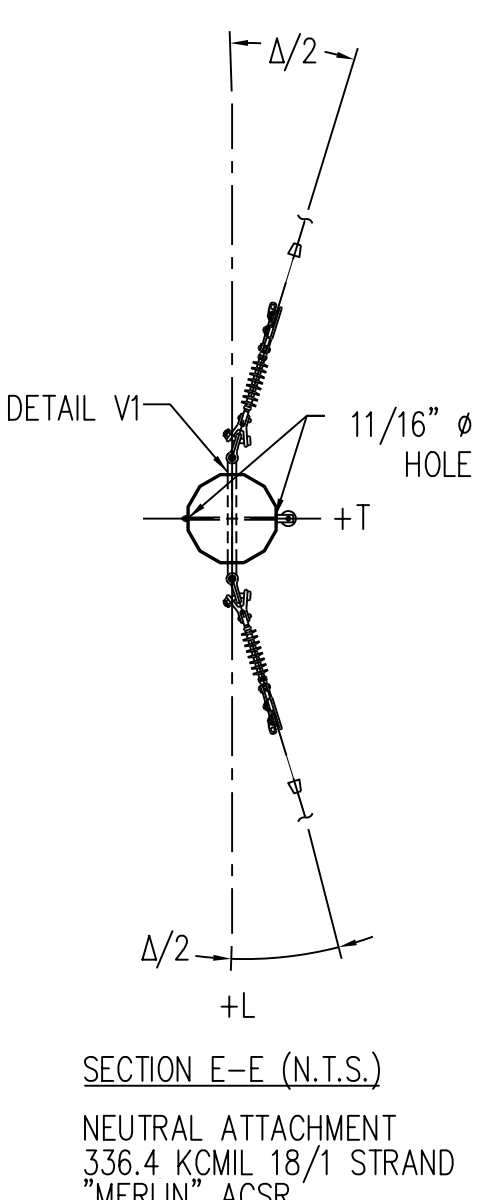
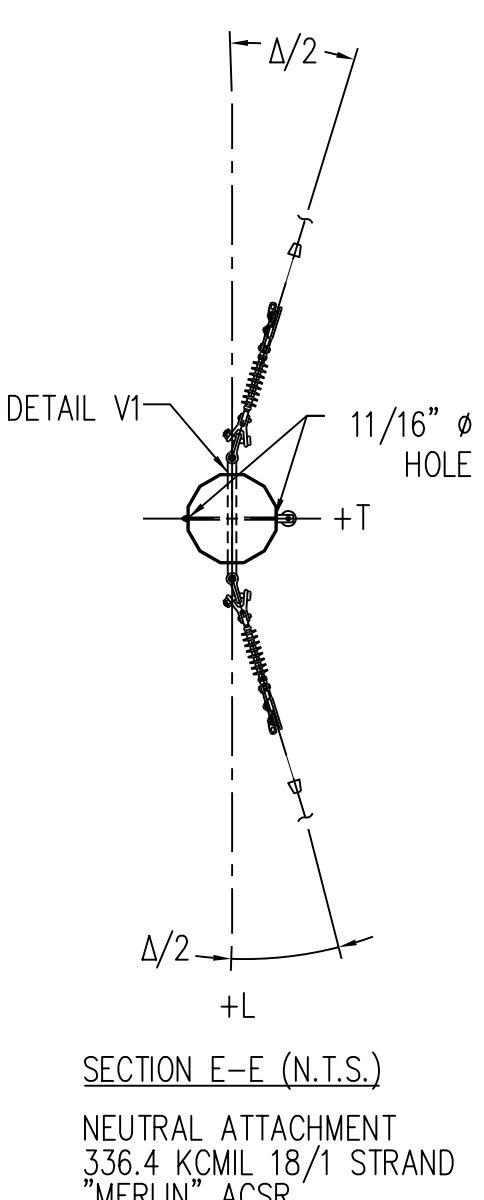
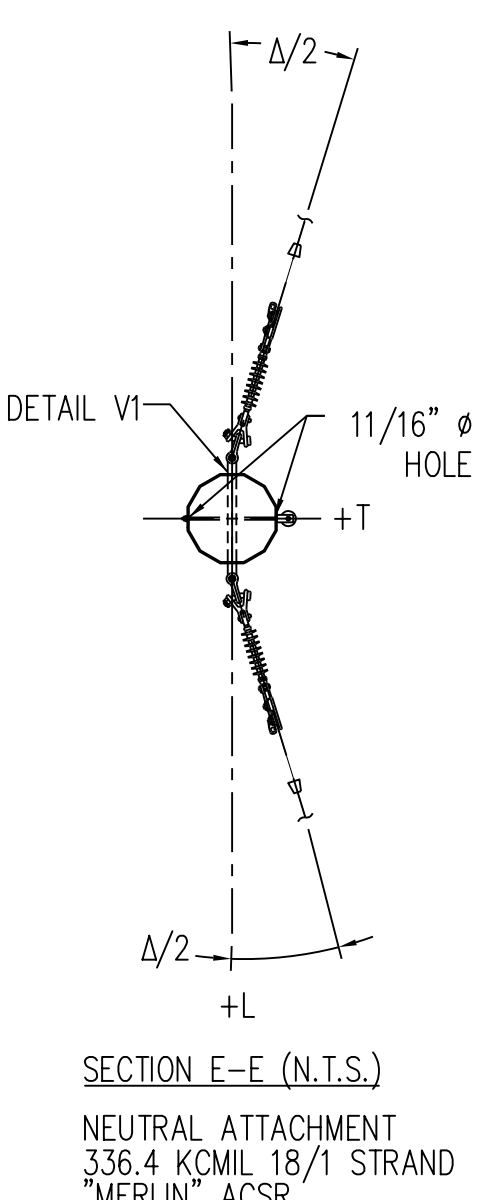
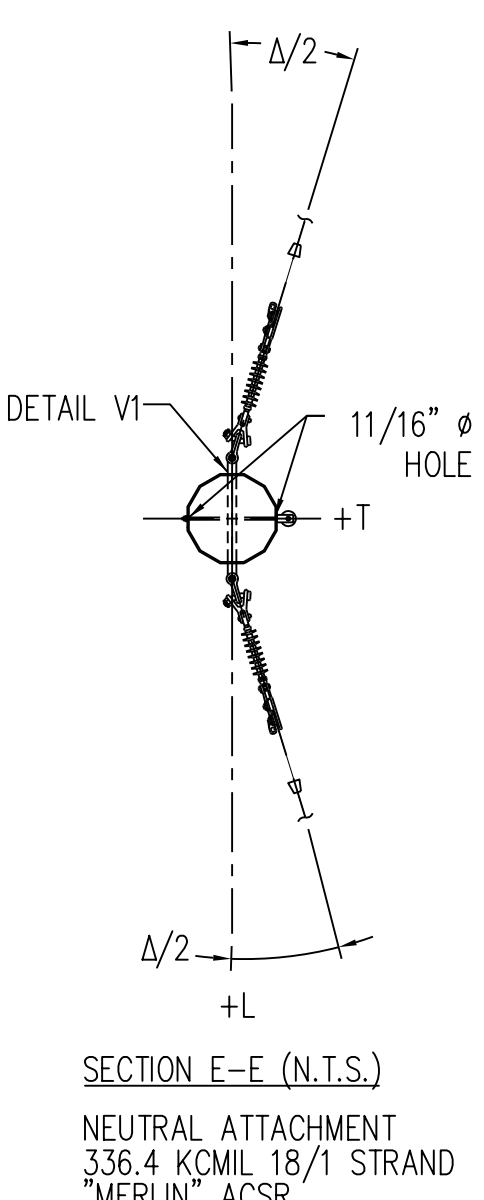
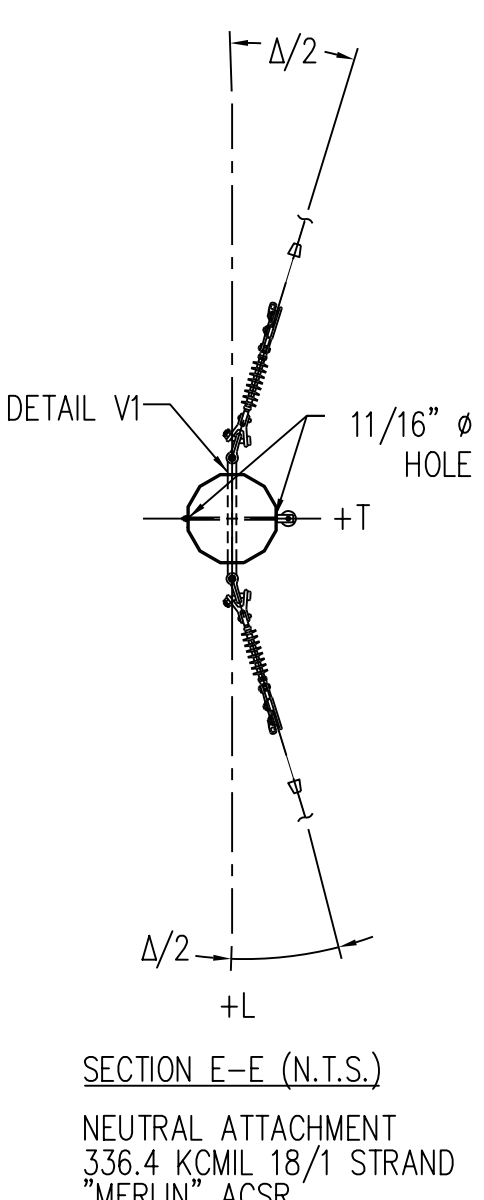
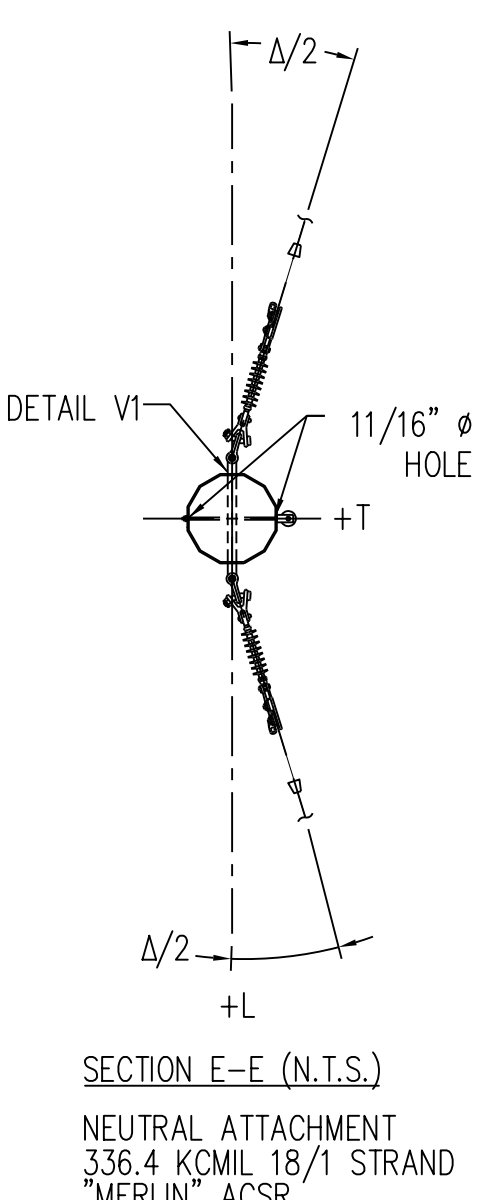
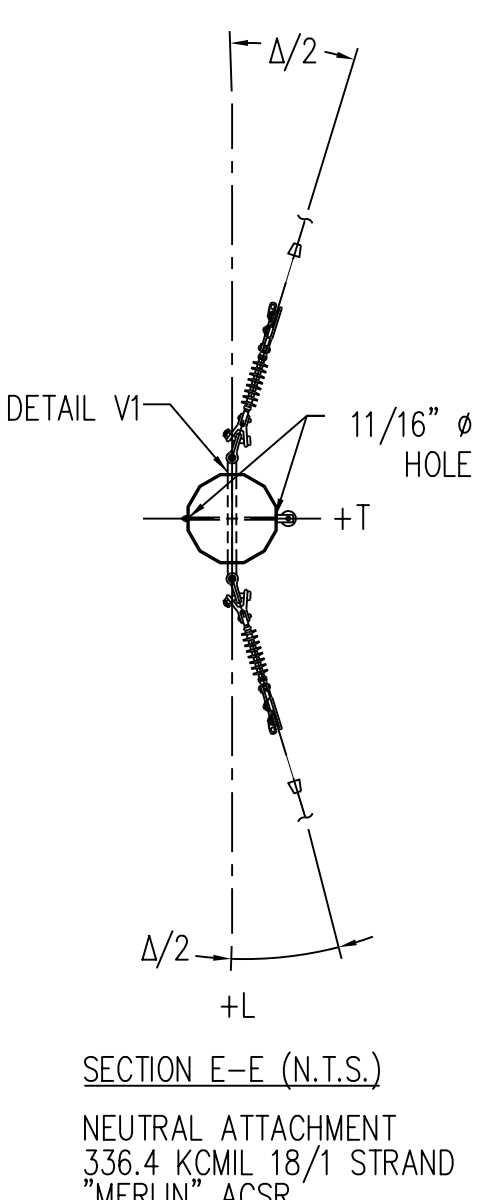
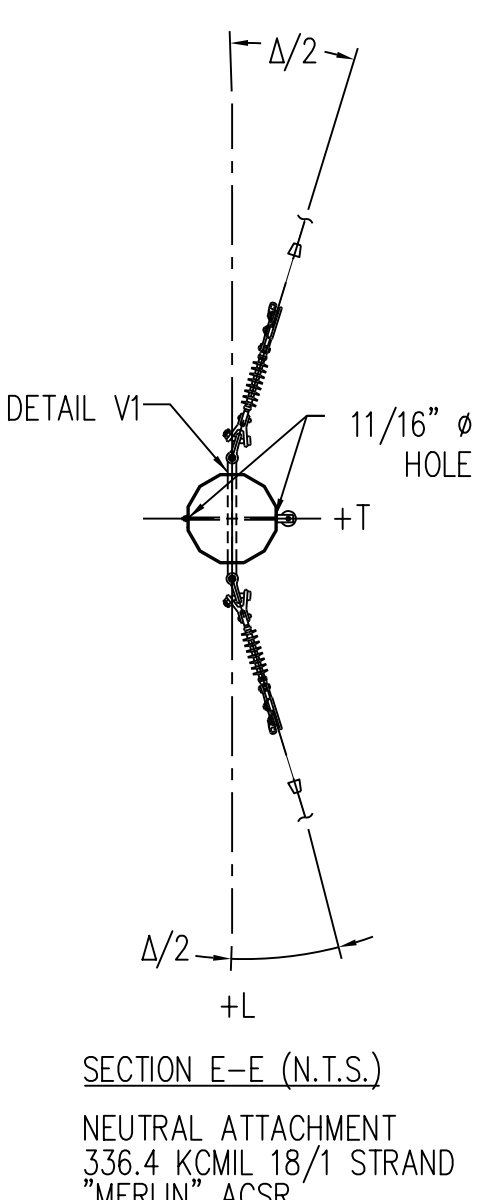
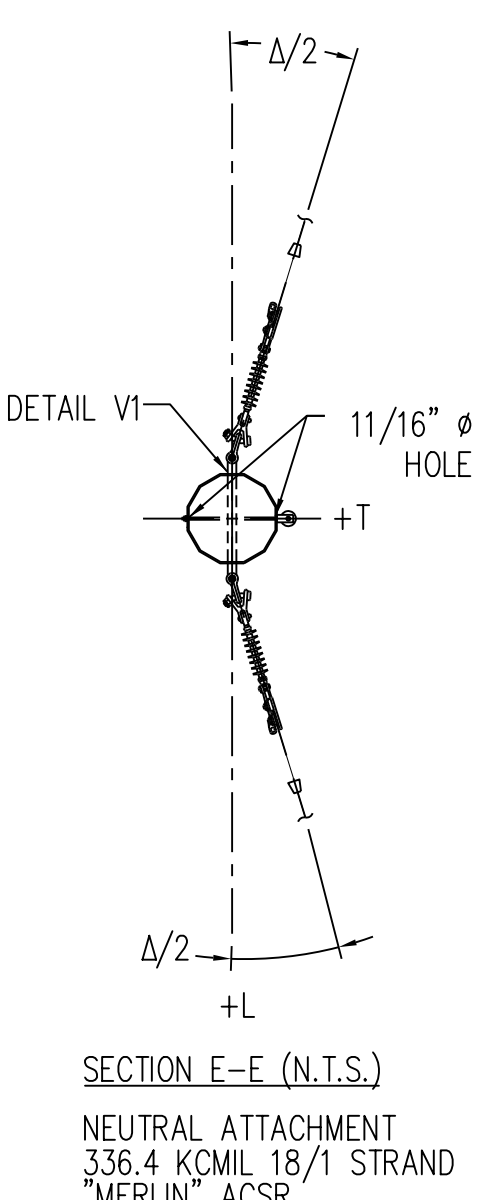
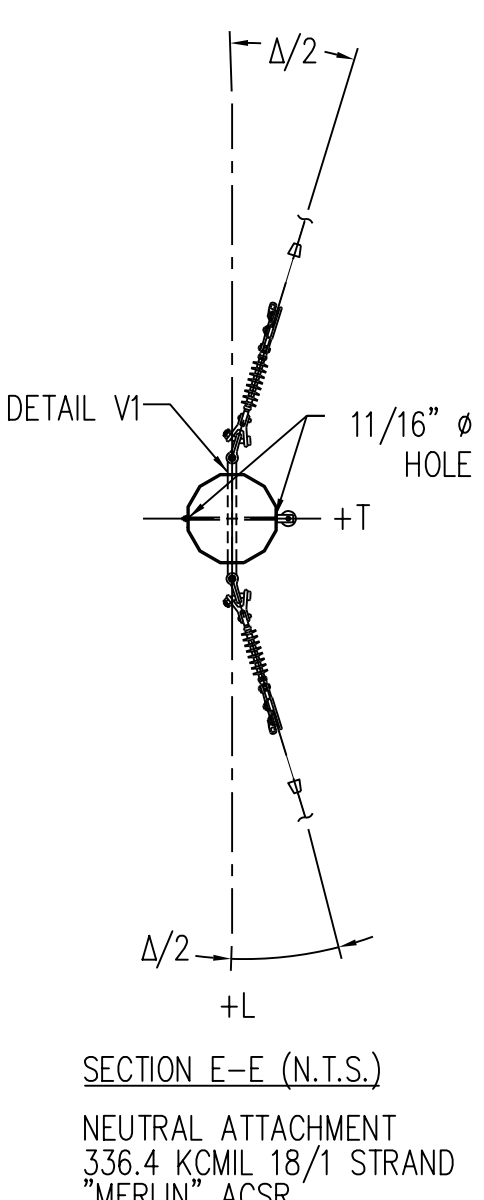
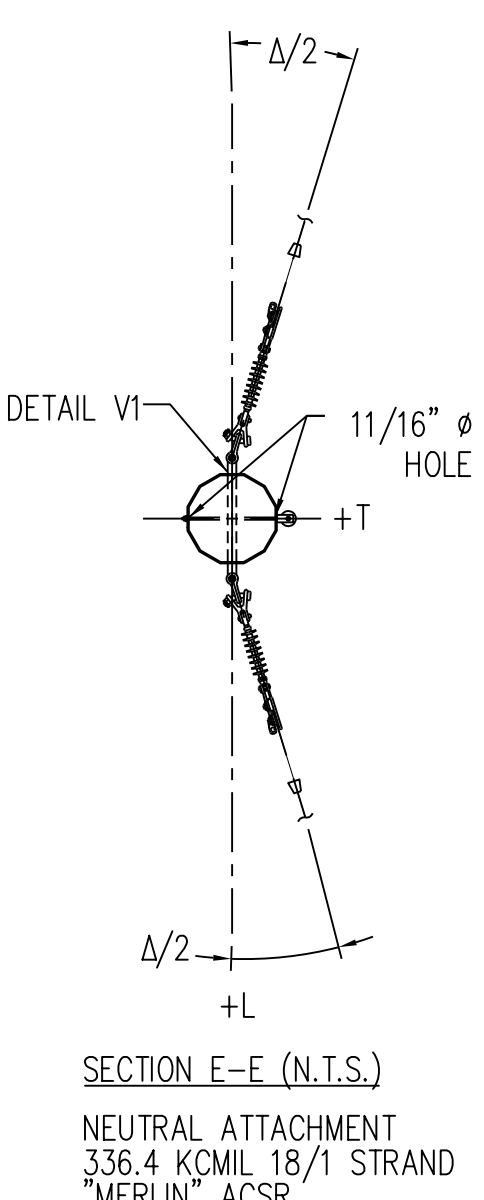
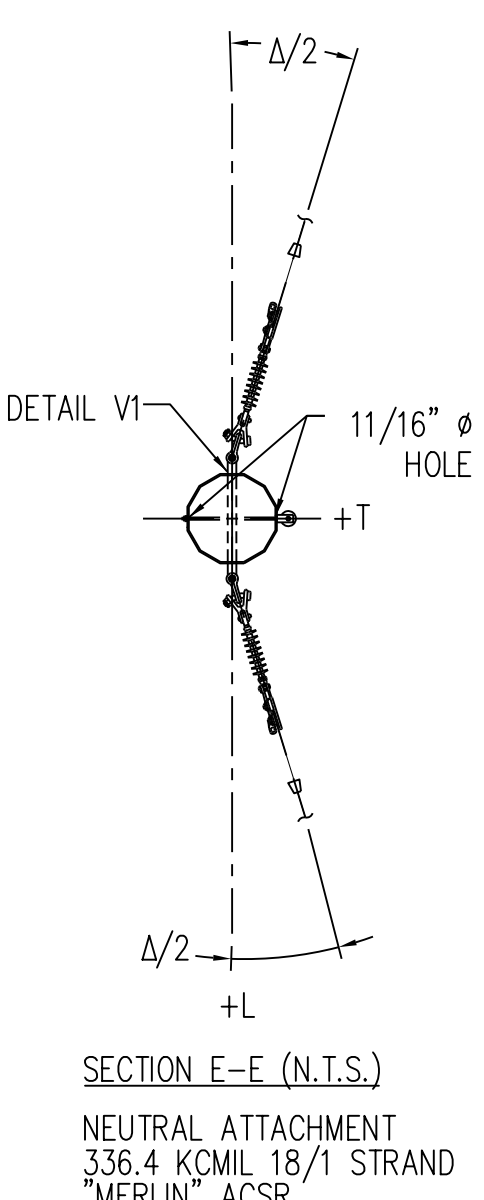
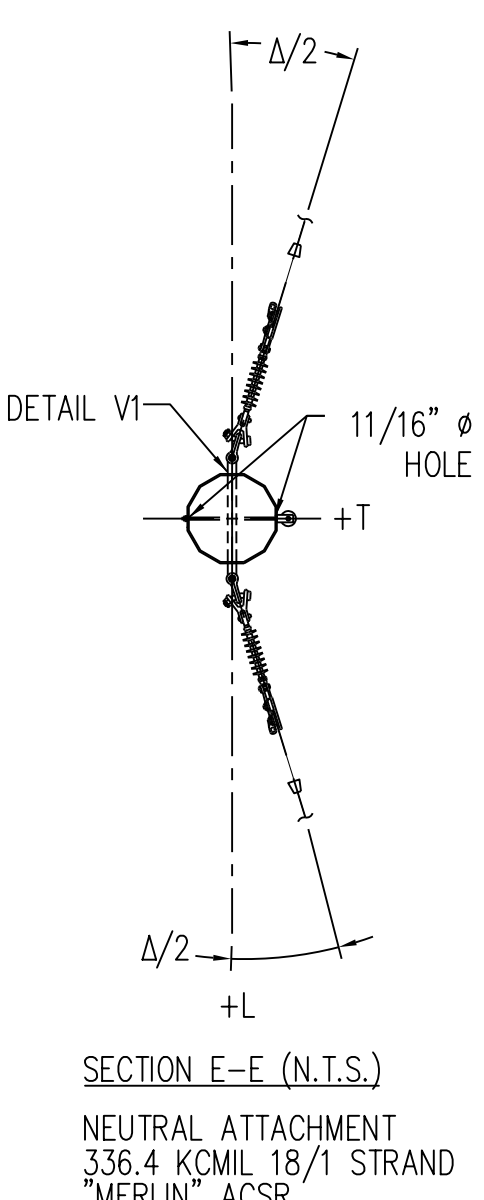
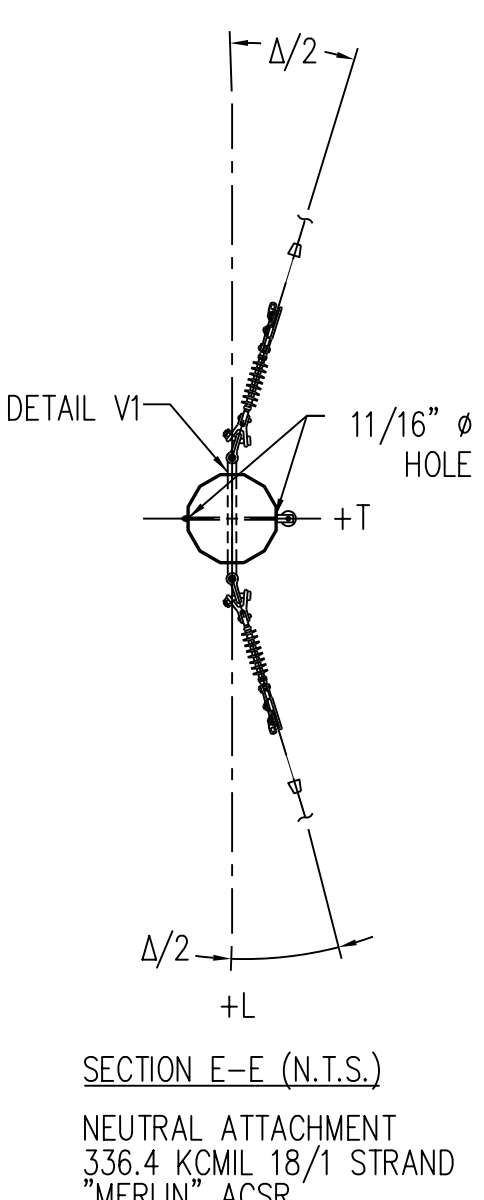
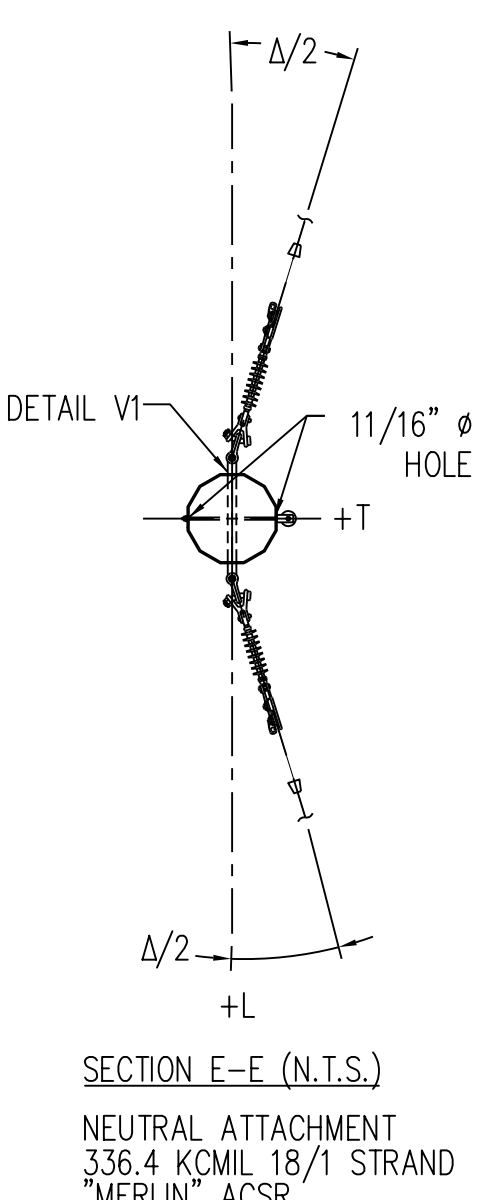
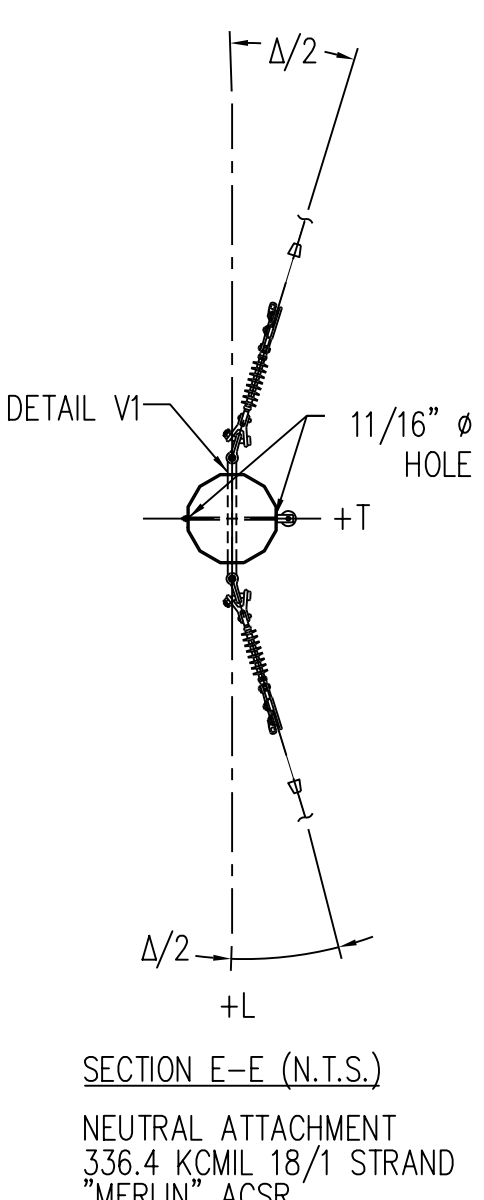
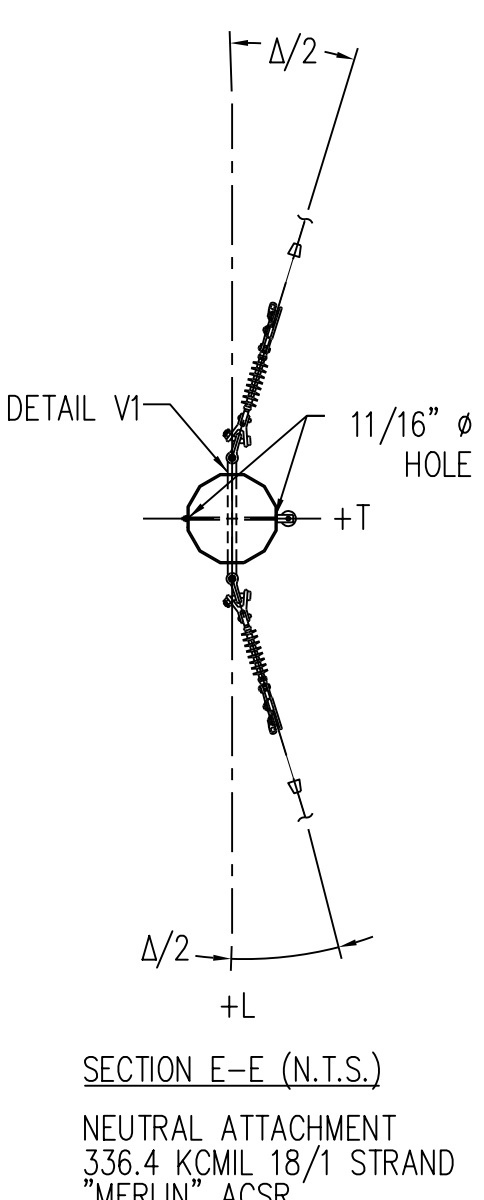
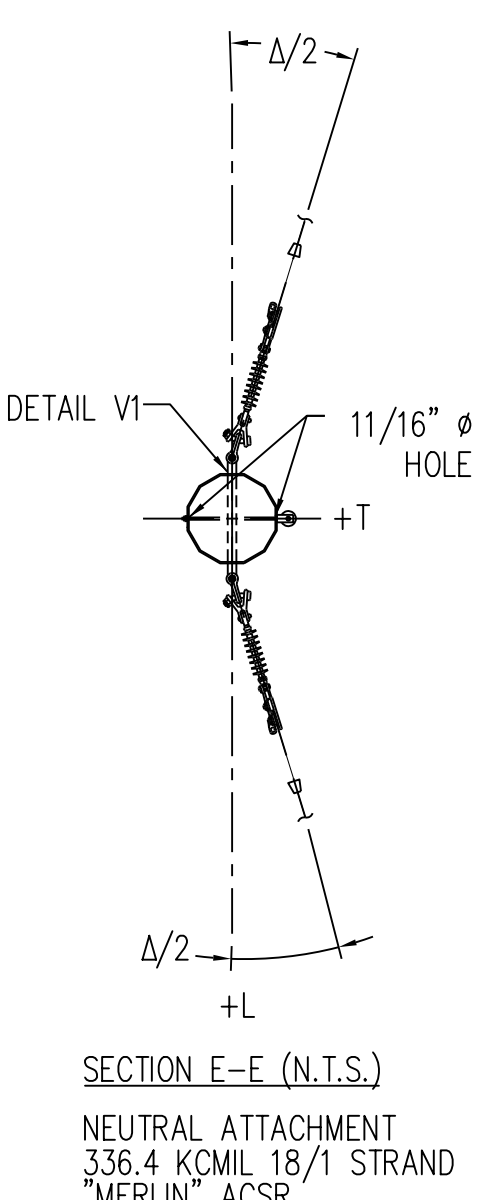
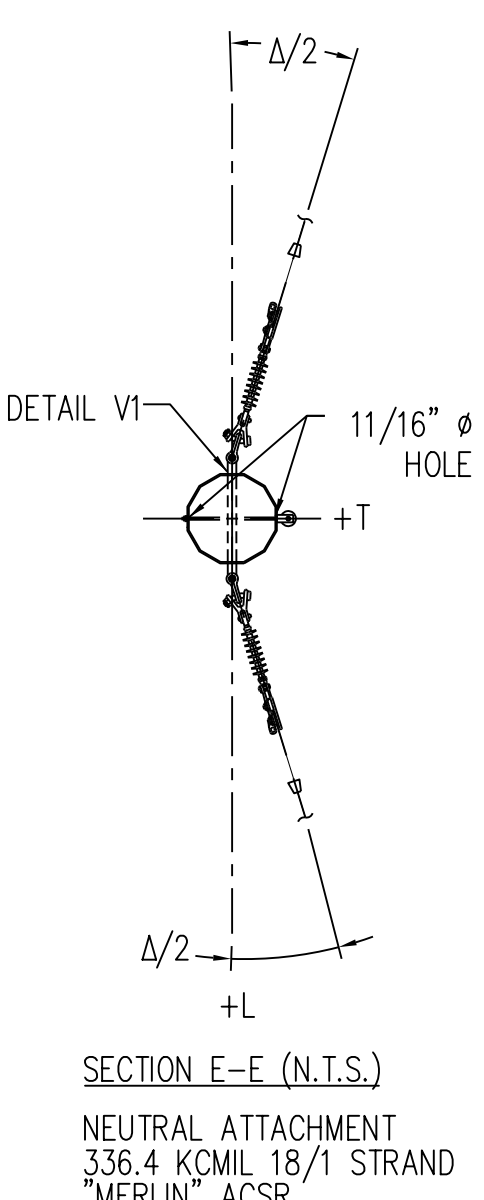
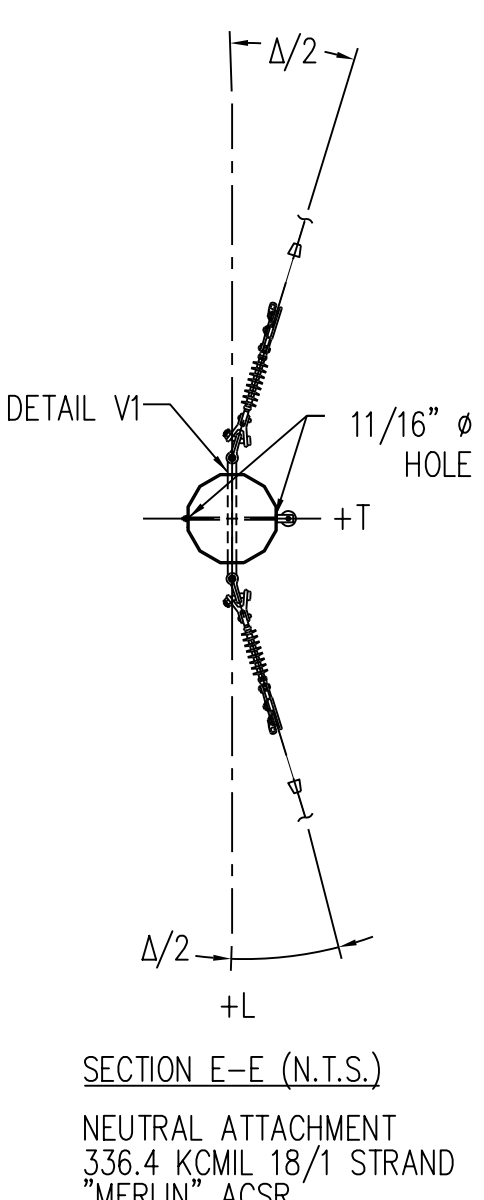
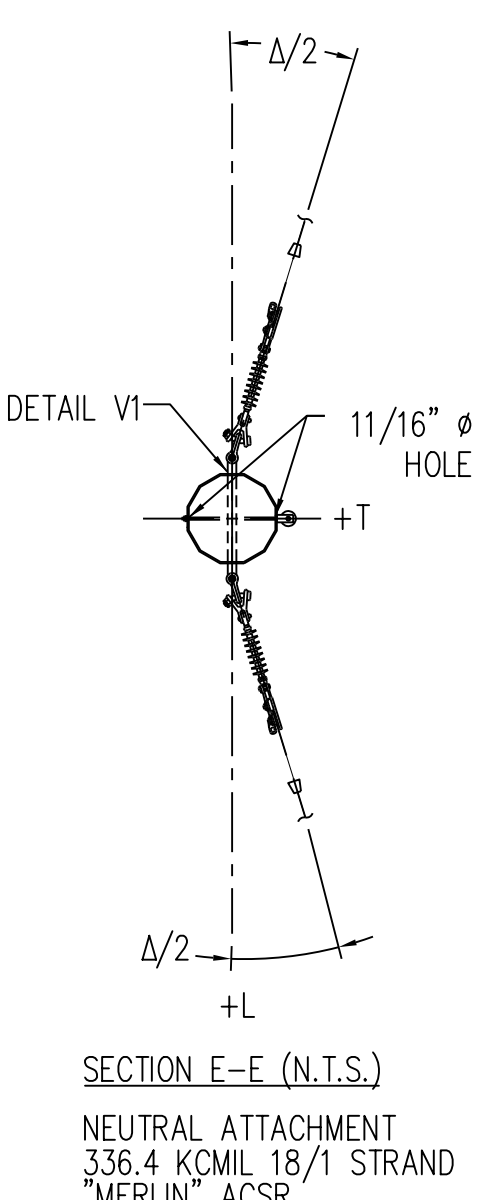
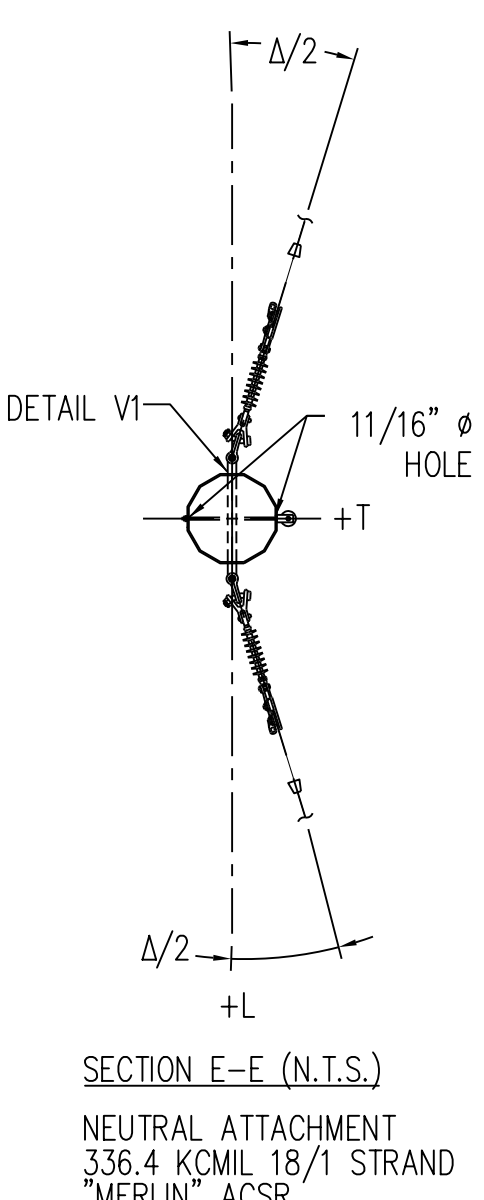
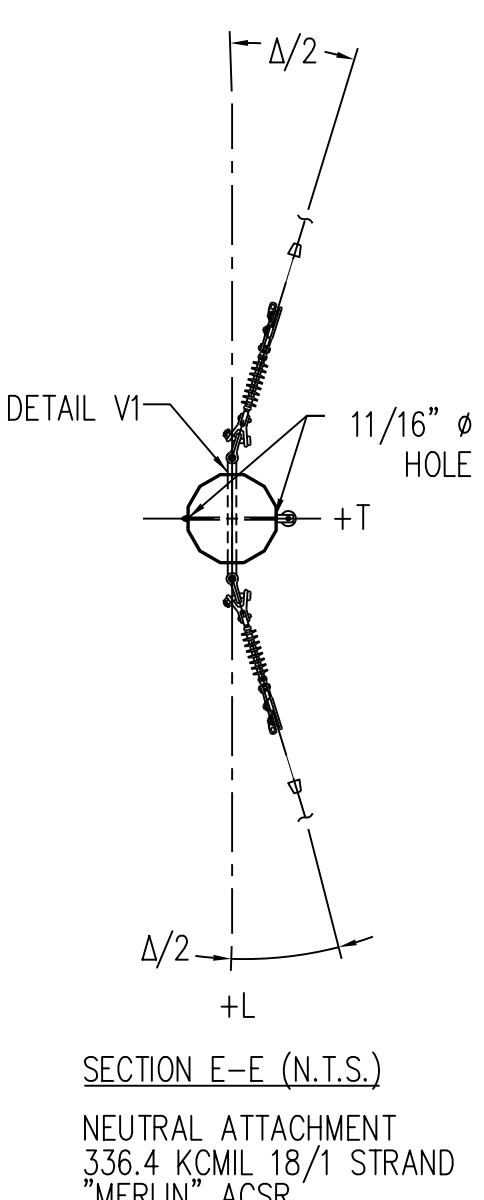
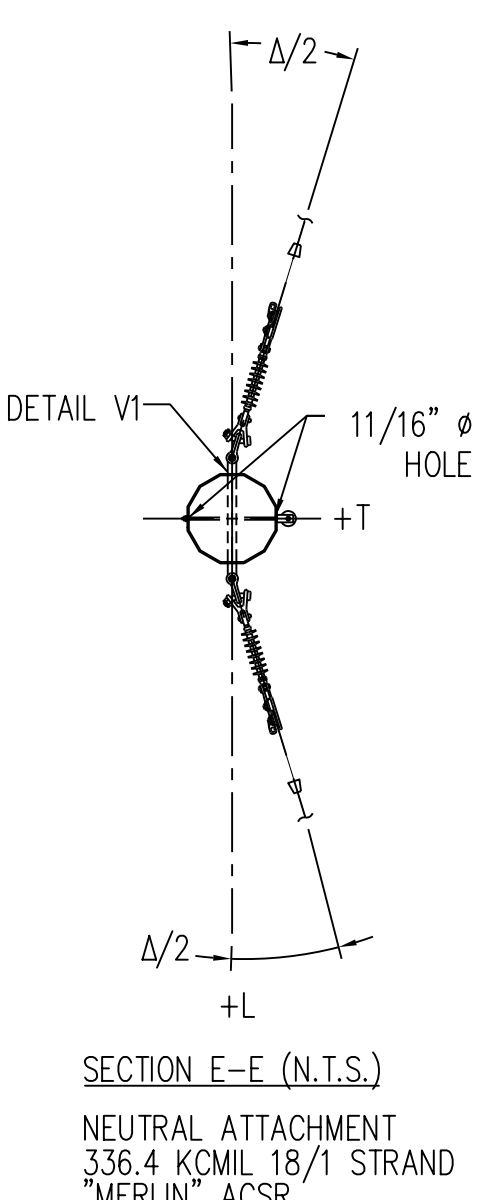
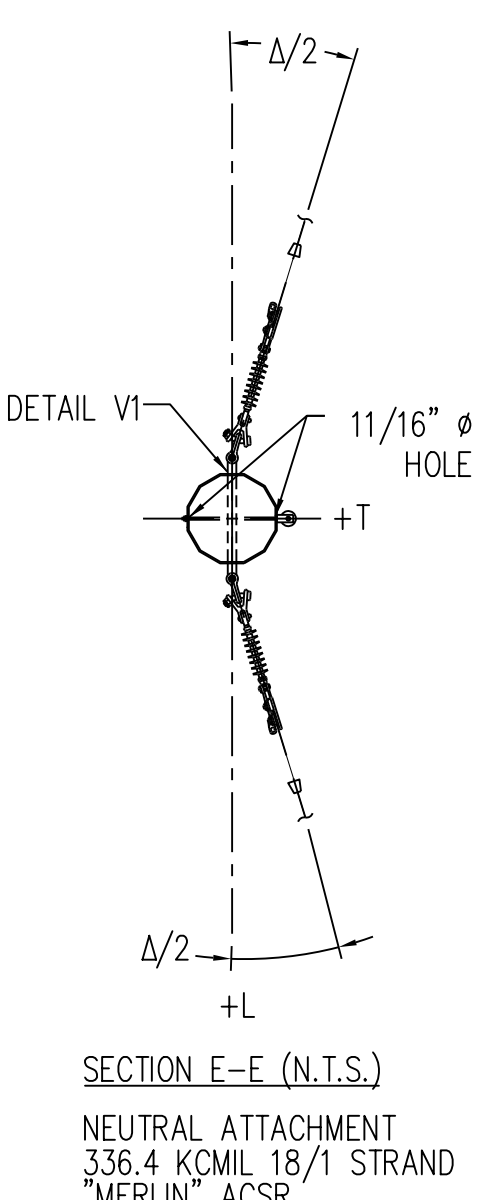
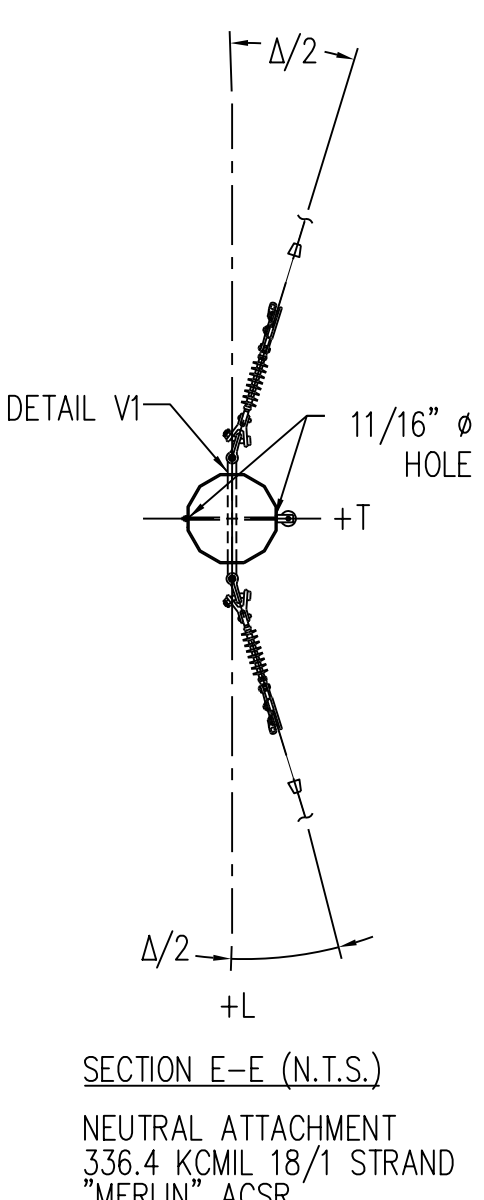
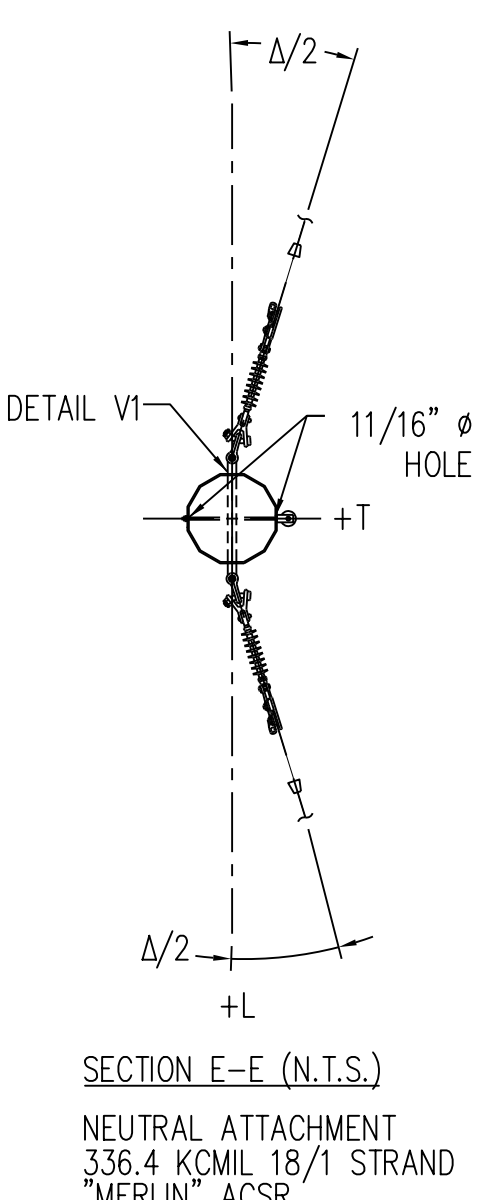
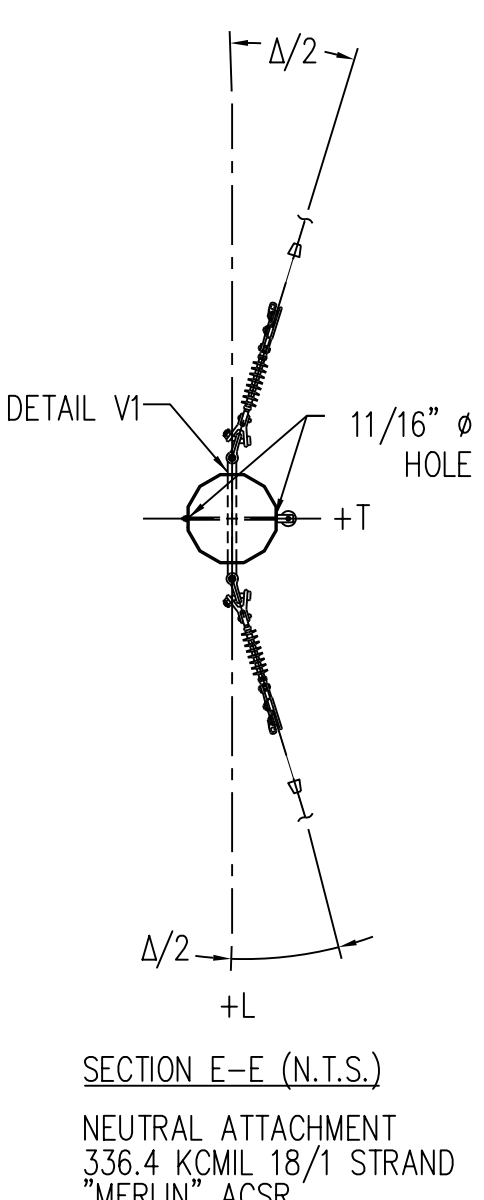
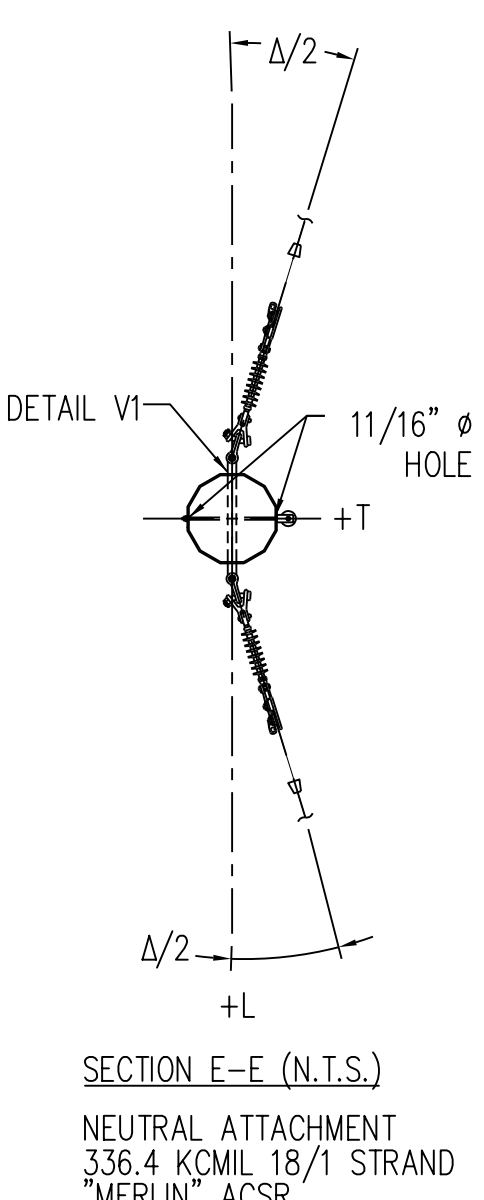
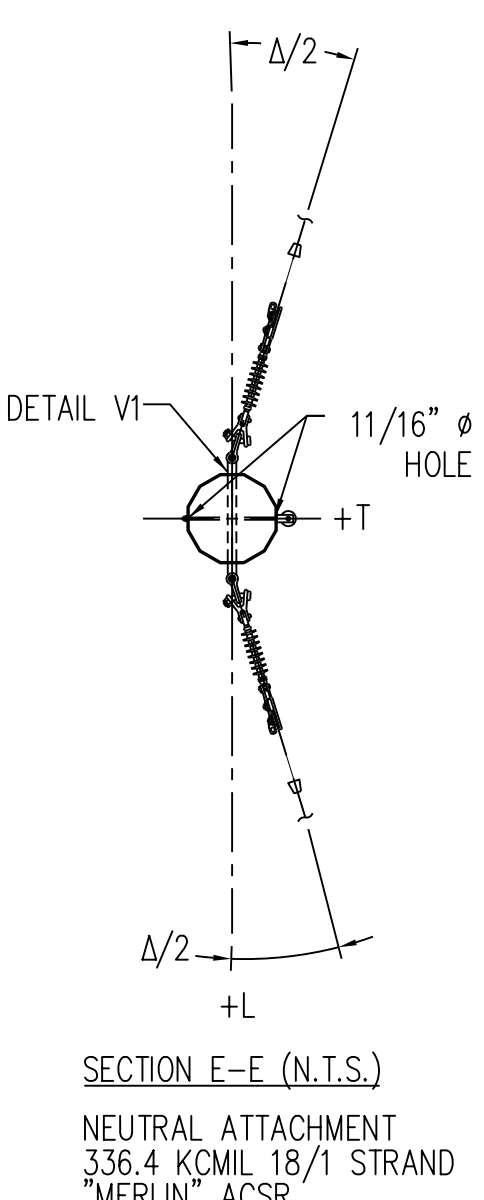
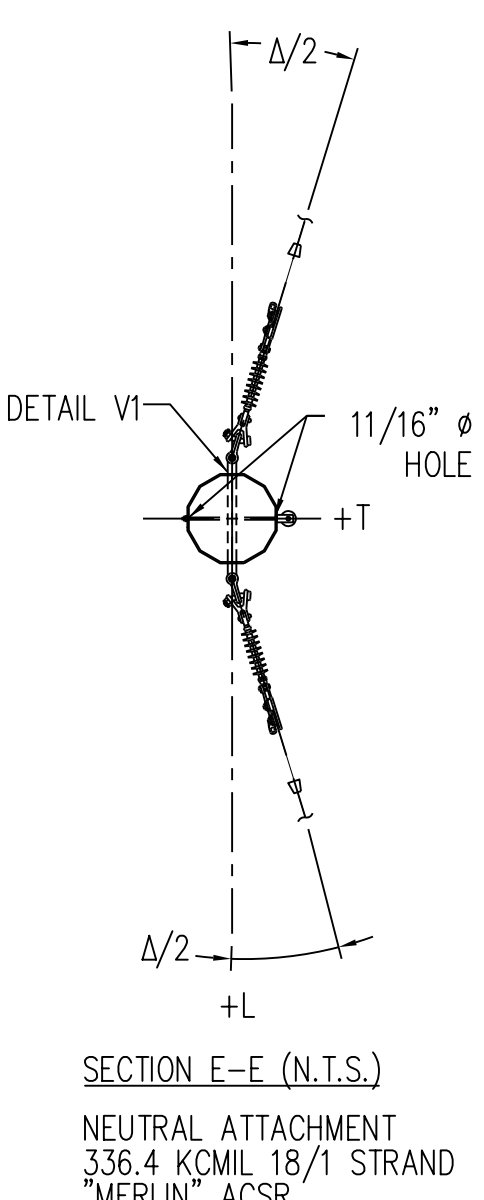
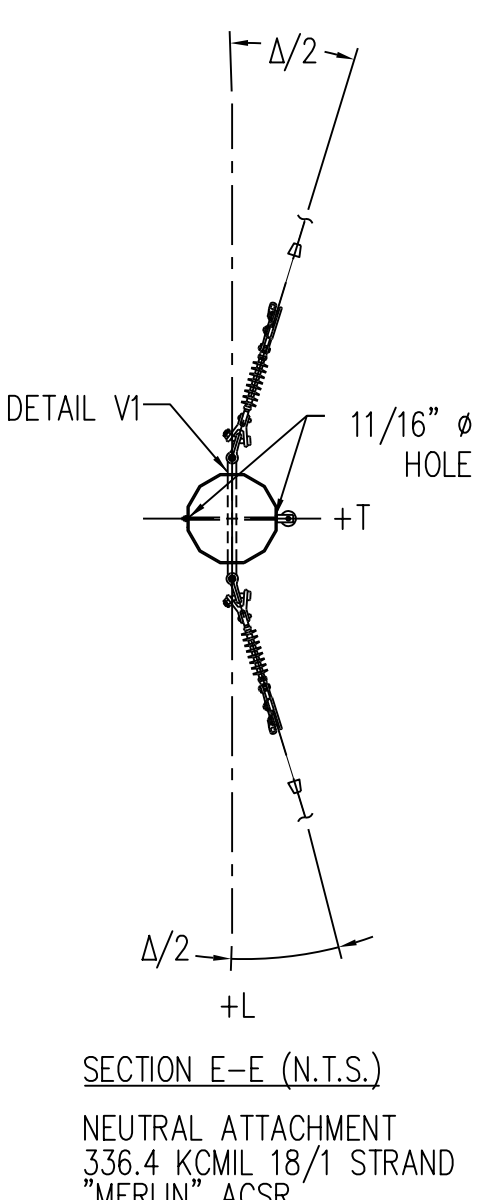
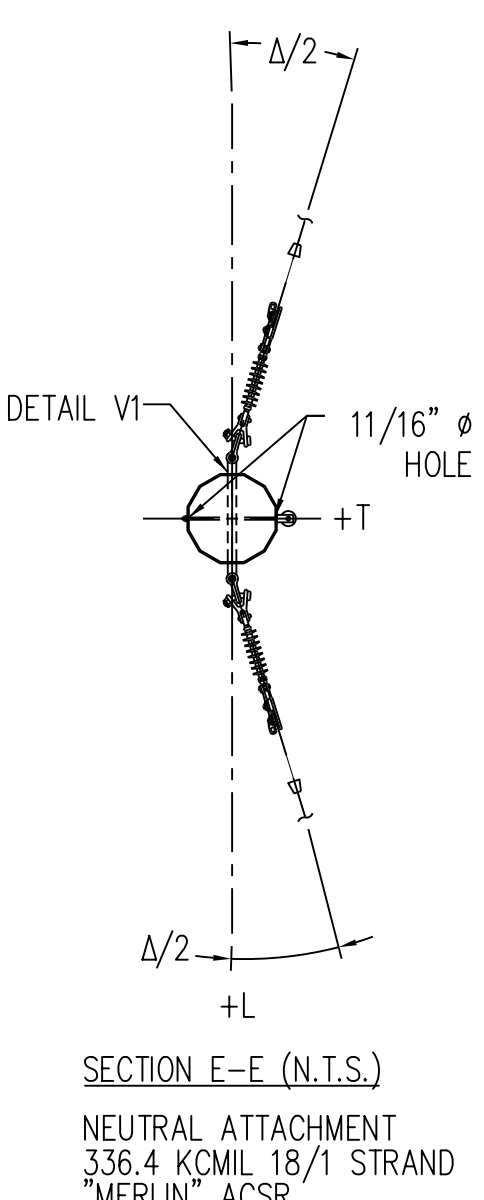
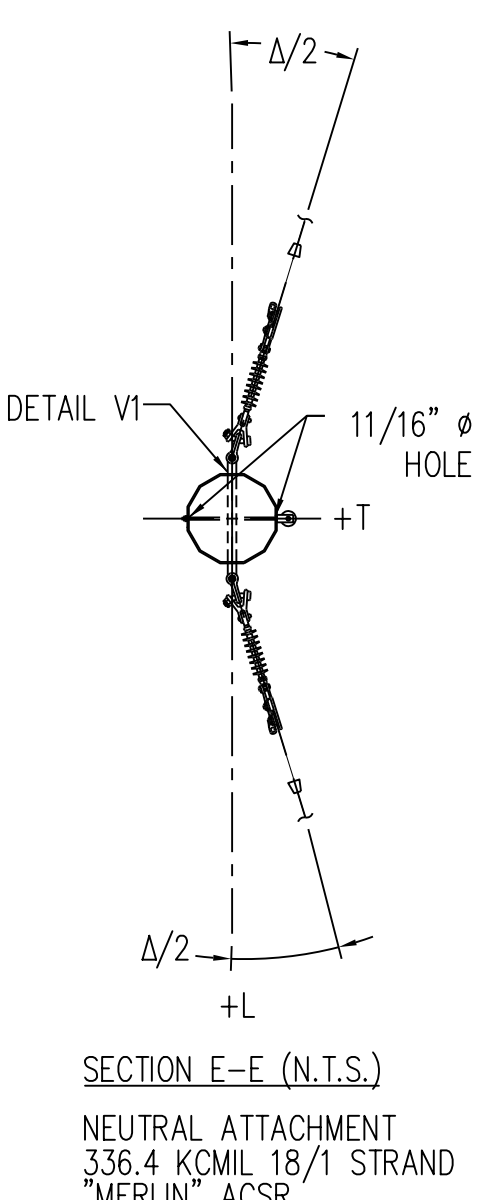
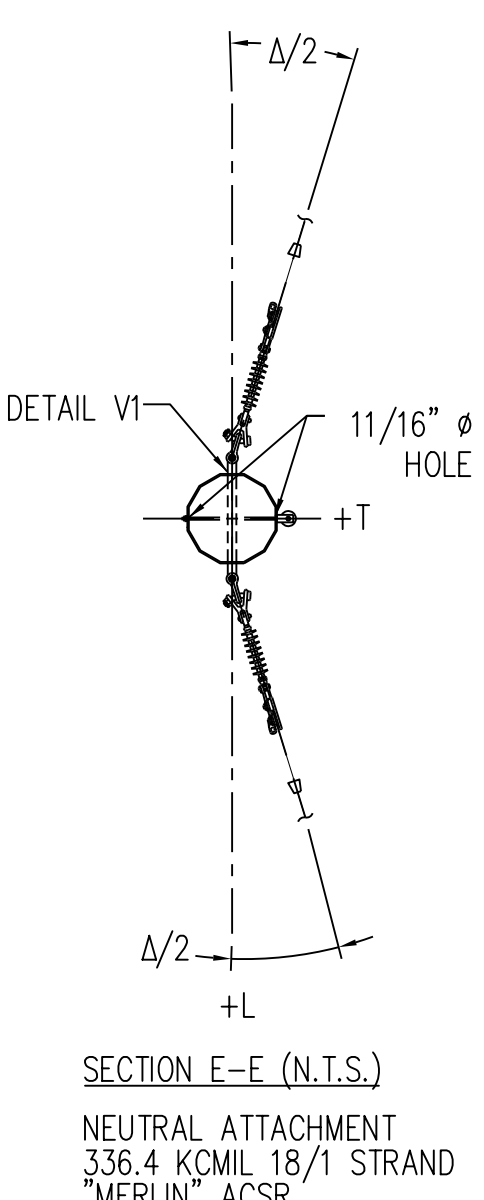
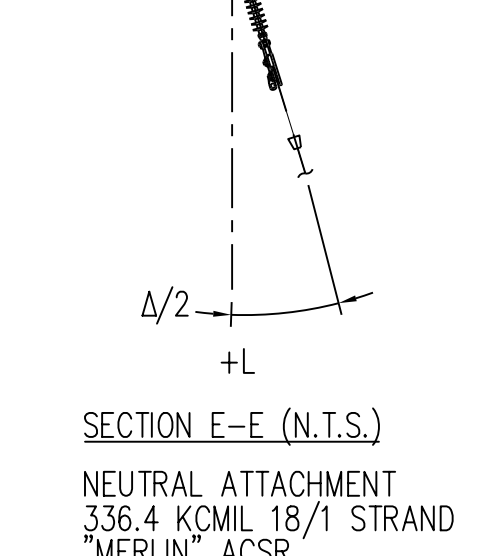
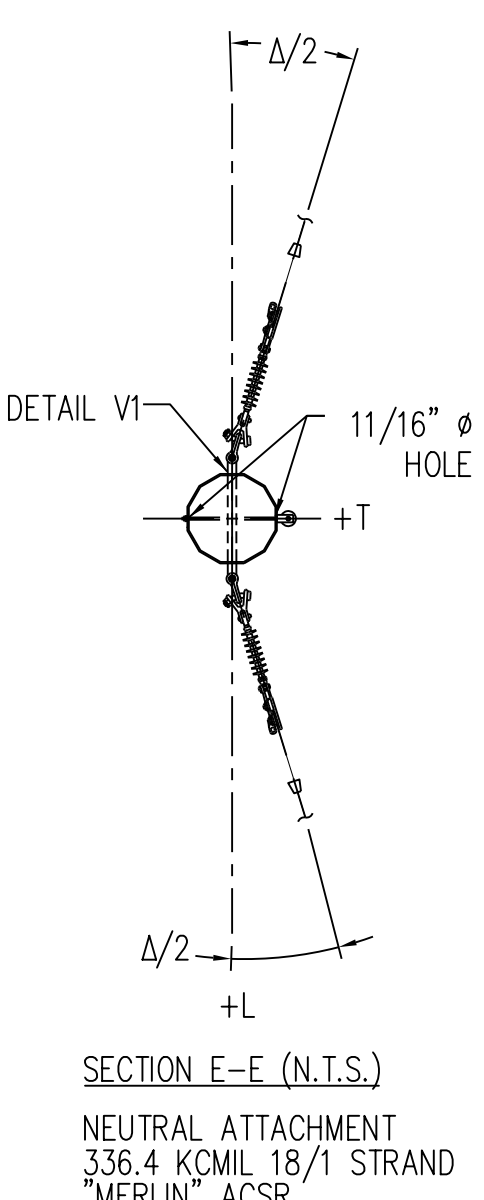
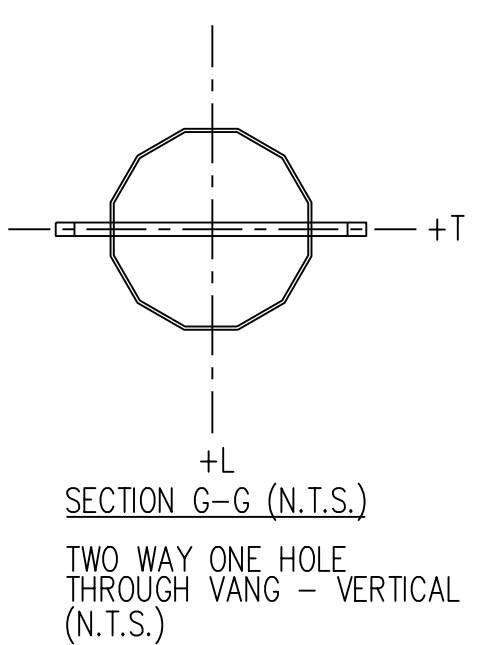
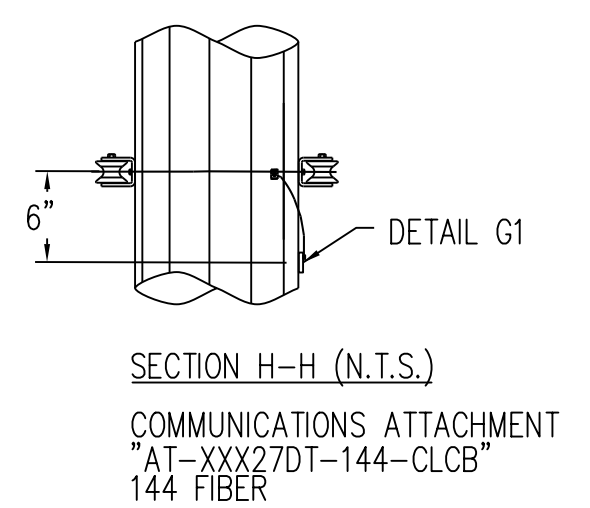
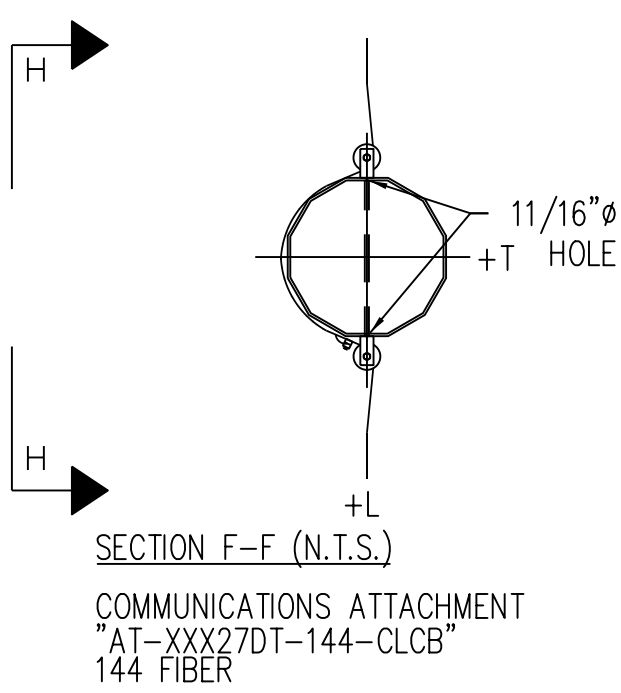
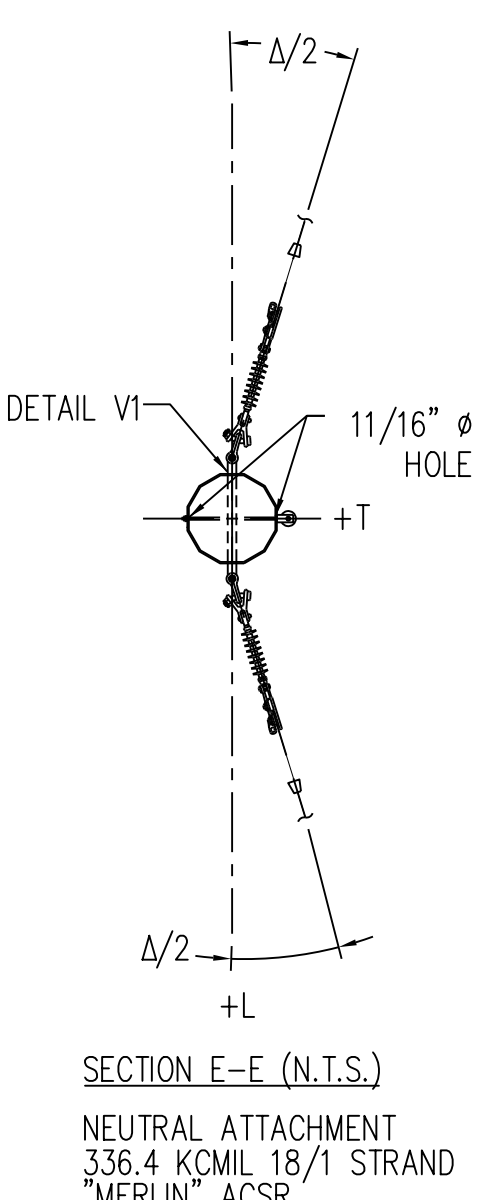
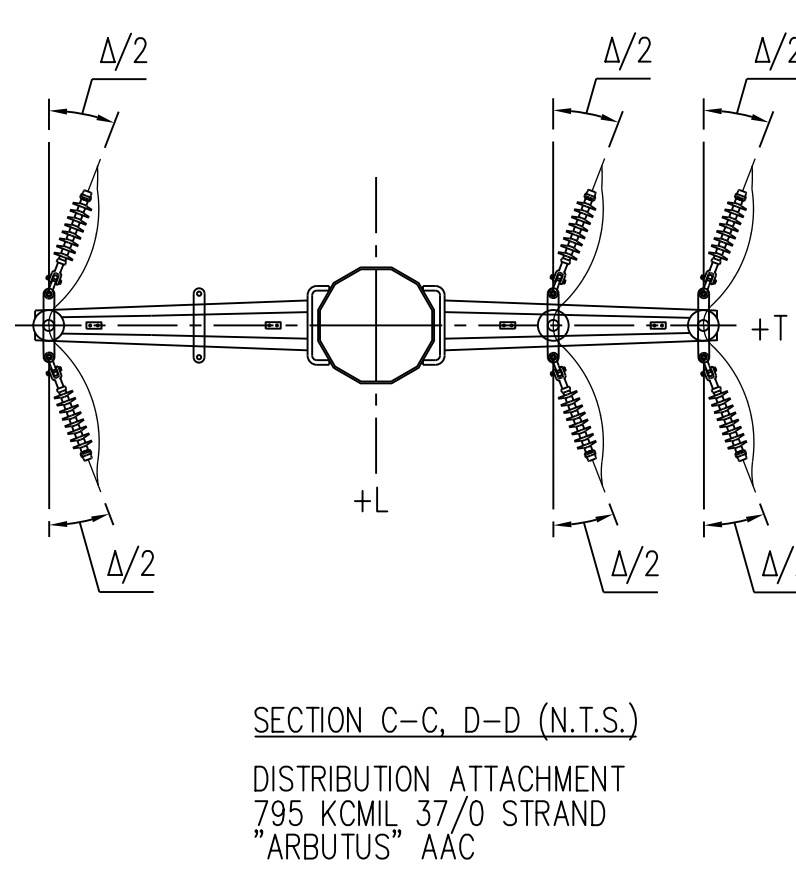
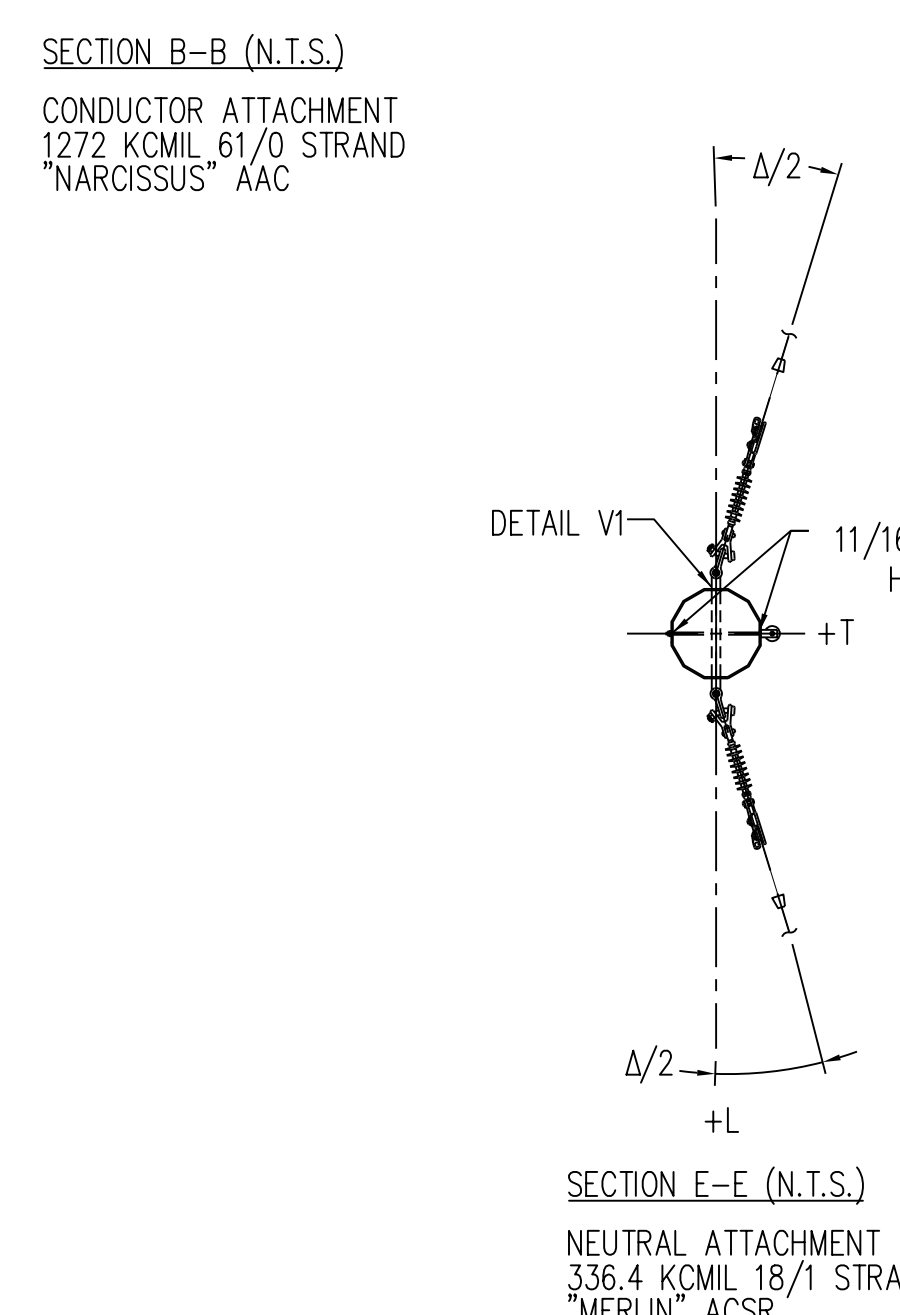
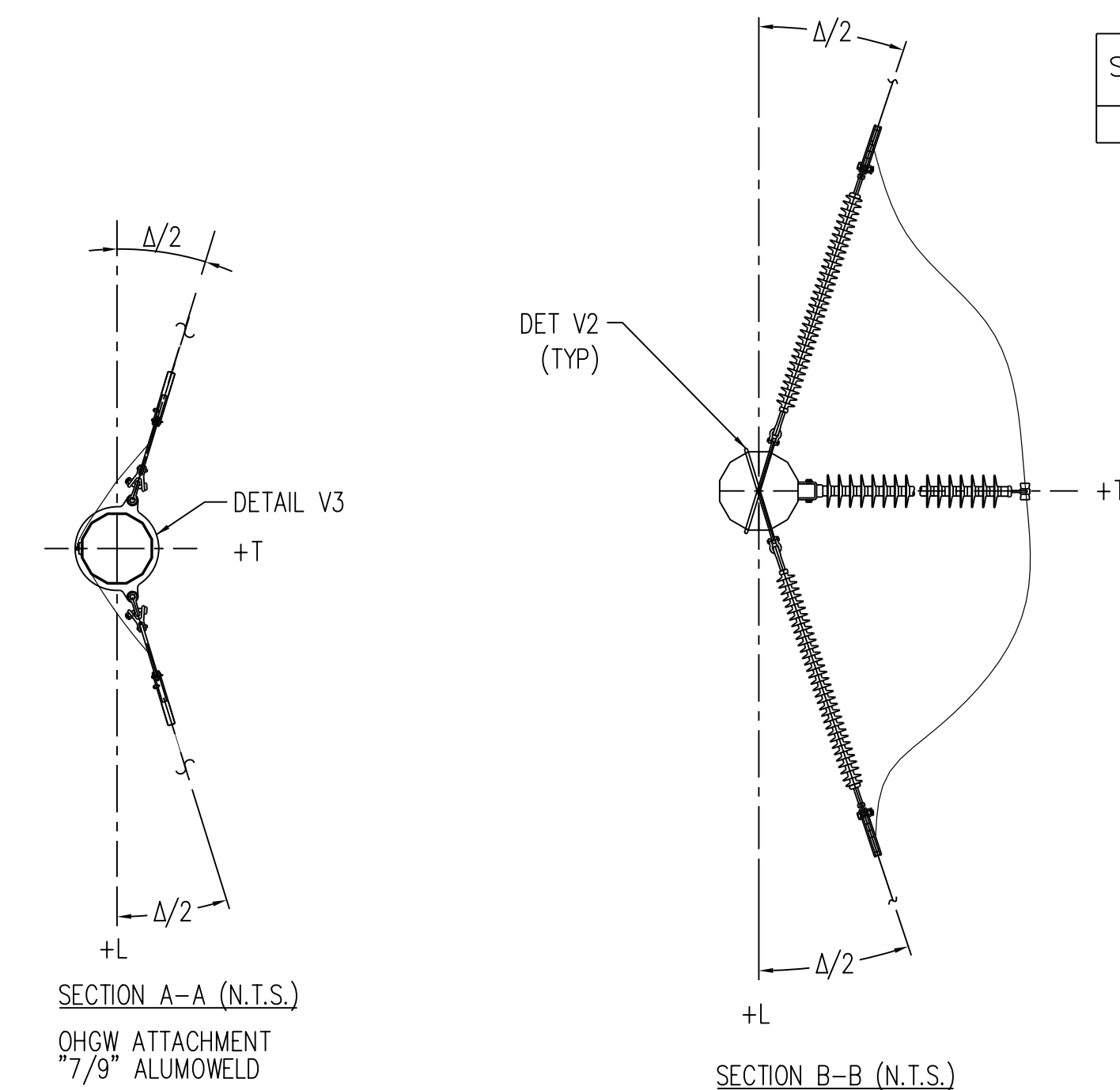
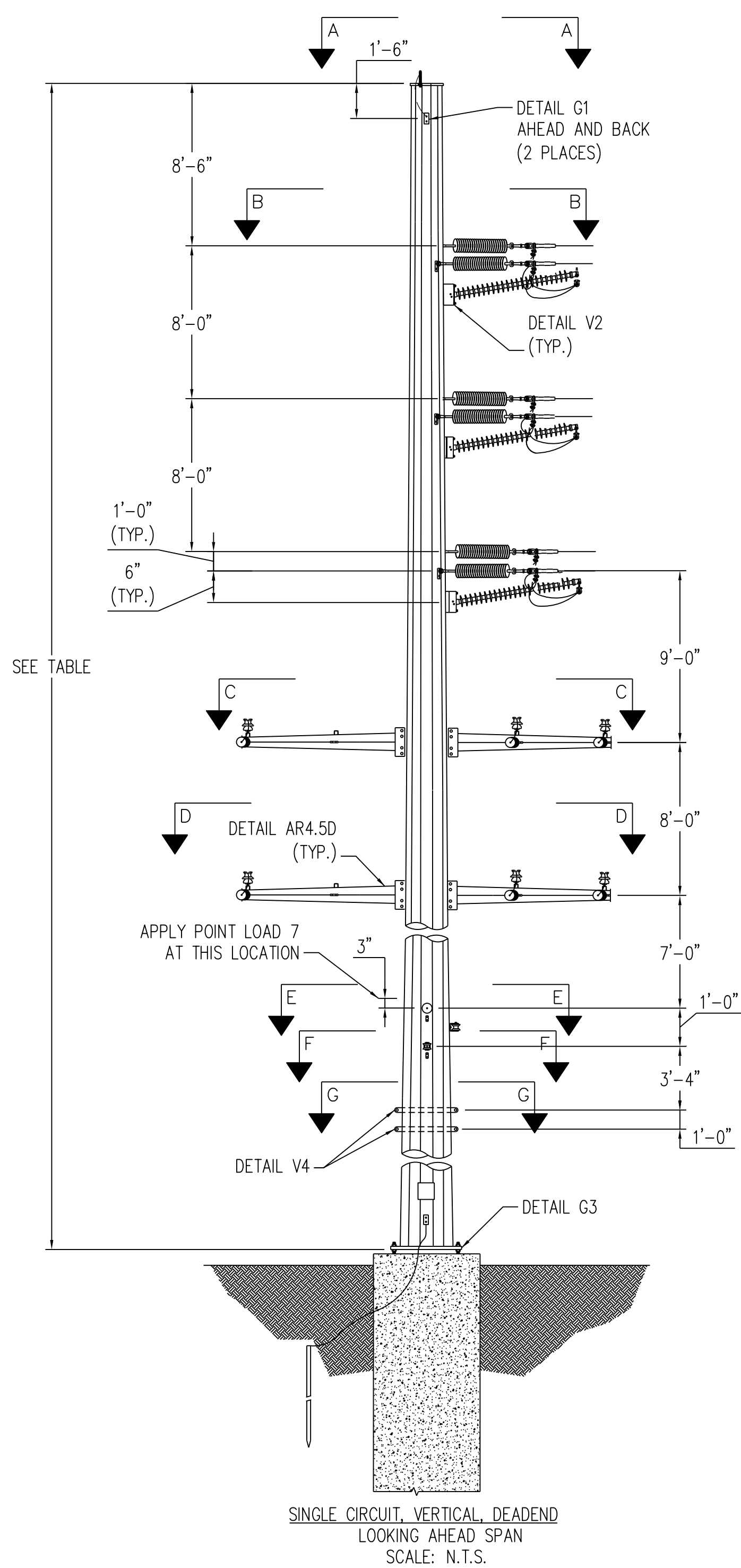

STR #	LENGTH (FT)	ANGLE Δ
22	100	15

LOAD	LOADING TABLE									
	CASE 1	CASE 2	CASE 3	CASE 4	CASE 5	CASE 6	CASE 7	CASE 10		
V1	300	200	700	200	100	500	200	300		
T1	2000	4600	1500	1100	2400	800	400	1200		
L1	1900	800	600	4800	2800	3700	1100	2500		
V2	1200	700	1600	700	400	900	500	1200		
T2	5800	12000	3700	3100	6300	2100	900	4400		
L2	900	1000	1100	12700	8000	9900	400	400		
V3	800	500	1200	500	300	800	300	4800		
T3	3400	5600	2400	1800	2900	1300	600	2600		
L3	800	800	900	8800	5600	7100	300	1500		
V4	300	100	600	200	100	500	100	100		
T4	2400	4600	1800	1300	2400	1000	300	1700		
L4	100	300	500	5100	3500	4700	100	400		
V5	200	100	700	200	100	500	100	100		
T5	700	1000	700	400	600	400	200	400		
L5	200	200	300	1800	1700	1900	-	100		
V6	400	100	900	300	100	600	200	200		
T6	800	1400	900	500	800	500	100	300		
L6	100	100	200	1600	2100	2200	100	100		
V7	2500	1000	6300	1400	600	3500	1000	4100		
T7	1300	1900	1400	5200	3600	4300	300	200		
L7	200	200	200	900	600	800	100	-100		
V8	1400	400	4800	800	300	2700	400	1700		
T8	800	1000	1000	2600	1900	2500	100	-100		
L8	100	100	100	500	300	400	100	-100		
W(PSF)	10	36.9	4.1	10	36.9	4.1	0	3		

ALL LOADS ARE IN LBS, ARE ULTIMATE, AND INCLUDE ALL OVERLOAD FACTORS. "W" REPRESENTS WIND PRESSURE (psf) TO BE APPLIED TO STRUCTURE.

LOAD CASES

- CASE 1 NESC MEDIUM: 15°, .25" ICE, 4 PSF WIND
OLF: L=1.65, T=2.50, V=1.50
- CASE 2 NESC HIGH WIND: 60°, 0" ICE, 120 MPH WIND
OLF: L=1.00, T=1.00, V=1.00
- CASE 3 NESC ICE WITH WIND: 15°, 1" ICE, 40 MPH WIND
OLF: L=1.00, T=1.00, V=1.00
- CASE 4 NESC MEDIUM DEADEND: 15°, .25" ICE, 4 PSF WIND
OLF: L=1.65, T=2.50, V=1.50
- CASE 5 NESC HIGH WIND DEADEND: 60°, 0" ICE, 120 MPH WIND
OLF: L=1.00, T=1.00, V=1.00
- CASE 6 NESC ICE WITH WIND DEADEND: 15°, 1" ICE, 40 MPH WIND
OLF: L=1.00, T=1.00, V=1.00
- CASE 7 DEFLECTION: 60 DEGREES, NO ICE, NO WIND, FINAL
OLF: L=1.00, T=1.00, V=1.00
- CASE 10 STRINGING: -20°, 0" ICE, 2 PSF WIND
OLF: L=1.50, T=1.50, V=1.50

WIRE DATA

OHGW: "7#9" ALUMOWELD
 115KV: 1272 KCMIL 61/0 STRAND "NARCISSUS" AAC
 12.47KV: 795 KCMIL 37/0 STRAND "ARBUTUS" AAC
 12.47KV CROSSING: 336.4 KCMIL 18/1 STRAND "MERLIN" ACSR
 DISTRIBUTION NEUTRAL: 336.4 KCMIL 18/1 STRAND "MERLIN" ACSR
 DISTRIBUTION NEUTRAL CROSSING: 1/0 6/1 STRAND "RAVEN" ACSR
 "MERLIN" ACSR
 ADSS: "AT-XXX27DT-144-CLCB" 144 FIBER

NOTES:

- ALL STATED LOADS ARE ULTIMATE VALUES AND INCLUDE OVERLOAD FACTORS AND INSULATOR WEIGHT.
- STRUCTURE AND ATTACHMENTS SHALL BE DESIGNED FOR THE SIMULTANEOUS APPLICATION OF DEAD LOAD, WIND ON THE STRUCTURE, AND WIRE LOADS FOR EACH LOADING CASE.
- STRUCTURE SHALL BE DESIGNED SELF SUPPORTING, GUYS ARE NOT PERMITTED. STRUCTURE SHALL MEET ALL TECHNICAL REQUIREMENTS OF THE STEEL POLE SPECIFICATIONS.
- WIND PRESSURES SHOWN ON LOAD WORKSHEET ARE BASED ON A SHAPE FACTOR OF 1.0.
- FABRICATOR MAY PROPOSE STRUCTURAL DETAILS DIFFERENT THAN THOSE SHOWN TO SIMPLIFY FABRICATION. VARIATIONS SHALL BE SUBMITTED TO ENGINEER IN WRITING.
- MINIMUM VANG PLATE THICKNESS = 1/2".
- WIND SHALL BE APPLIED IN THE DIRECTION WHICH RESULTS IN THE MOST SEVERE EFFECT.
- THE DEFLECTION AT THE POLE TOP SHALL BE LIMITED TO 1.5% OF THE POLE HEIGHT UNDER THE DEFLECTION CASE. POLES MAY BE CAMBERED TO FALL WITHIN THE DESIGN LIMIT.
- MAXIMUM DEFLECTION AT TOP OF THE STRUCTURE SHALL BE LIMITED TO 10% OF STRUCTURE HEIGHT UNDER ALL LOAD CASES WITH THE EXCEPTION TO THE 60° NO WIND LOAD CASE.
- POLE DESIGN AND FABRICATION SHALL INCLUDE PROVISIONS FOR A SLIP JOINT TO LIMIT LOWEST POLE SEGMENT EXTENSION ABOVE GRADE TO 12'-0" MAXIMUM.
- ALL STRUCTURES SHALL BE GALVANIZED STEEL.
- ORIENT SINGLE SIDED VANGS FOR HARDWARE SHOWN ON DRAWINGS.
- MANUFACTURER SHALL APPLY POINT LOADS NECESSARY TO CREATE THE MOST SEVERE EFFECTS ON ALL MEMBERS INCLUDING ARMS, POLES, BASE PLATES, ETC.

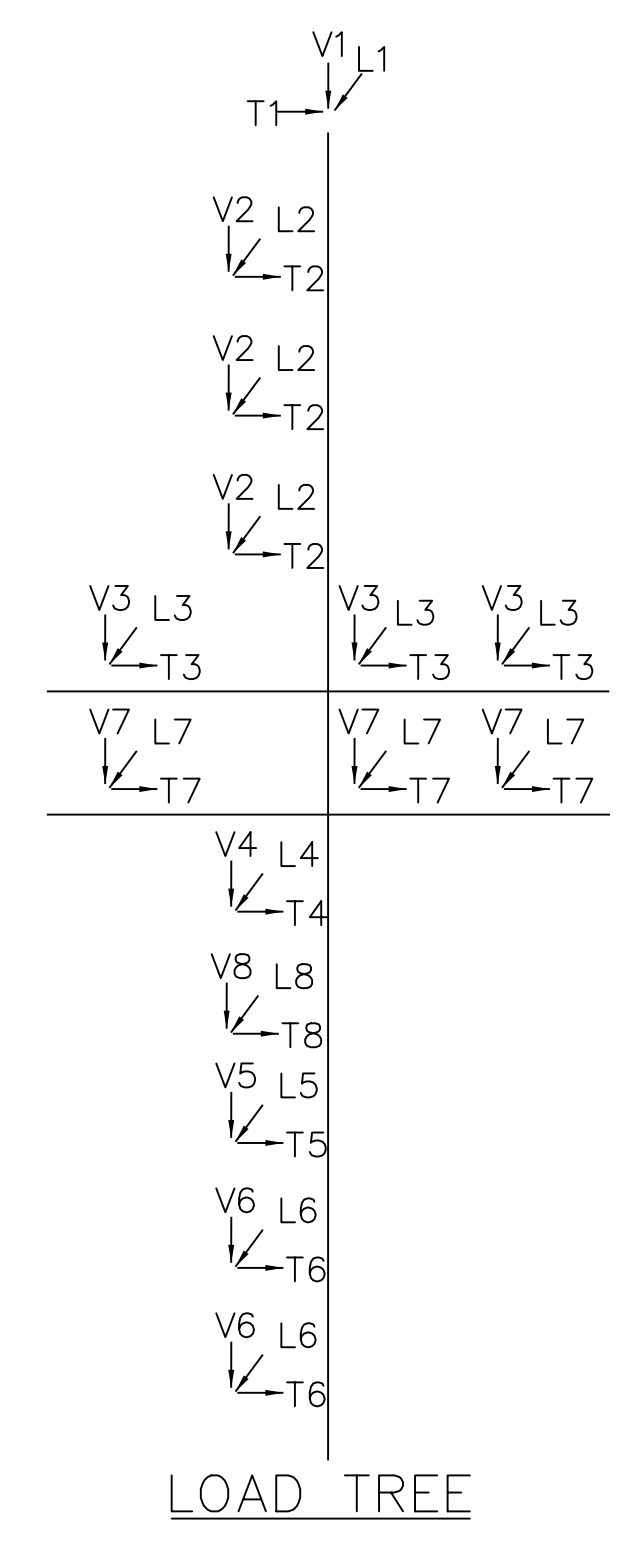
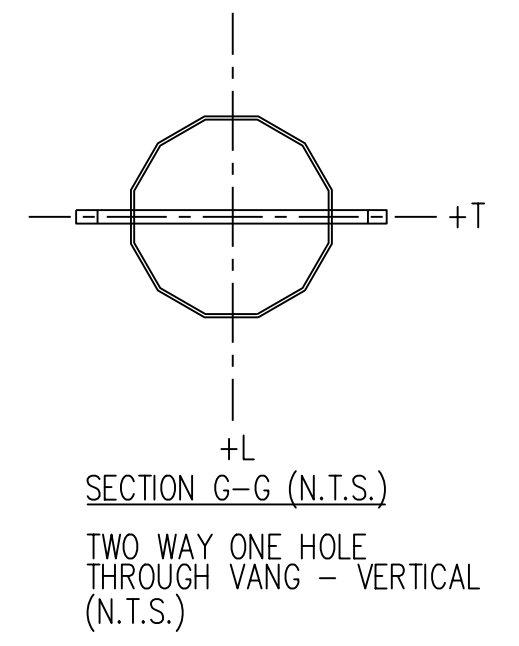
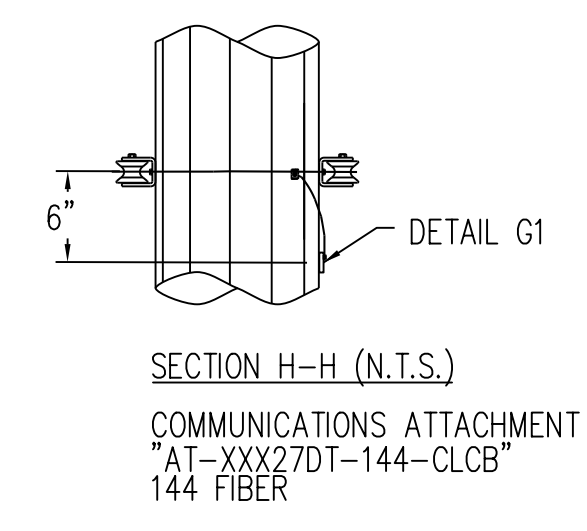
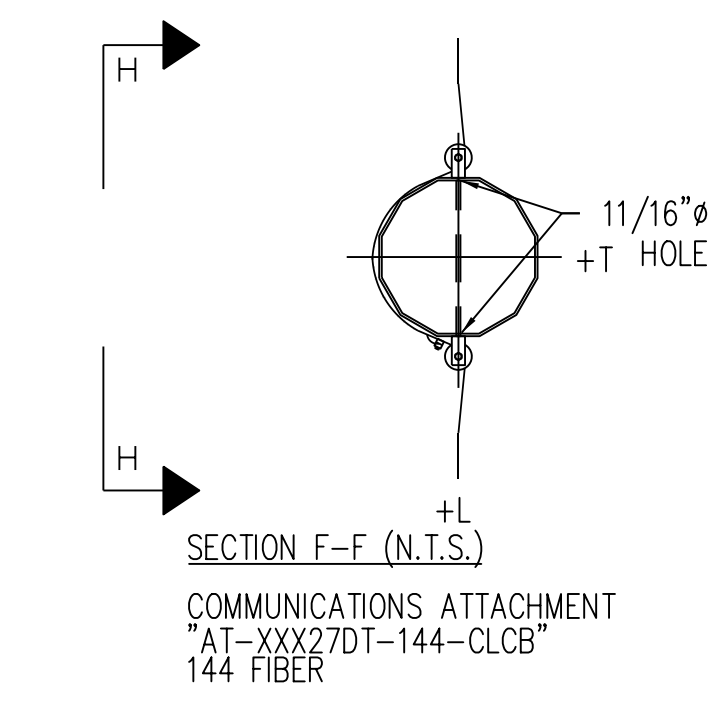
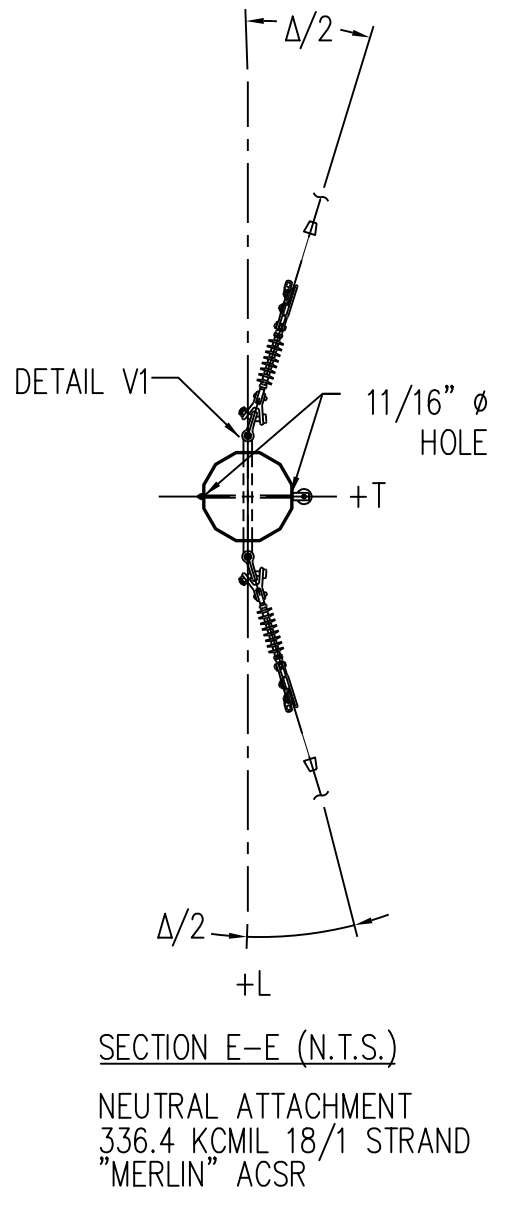
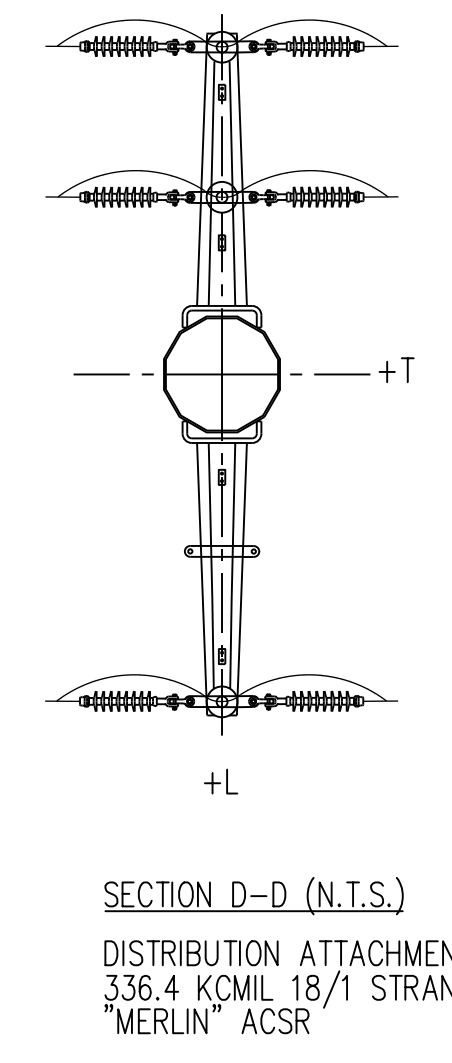
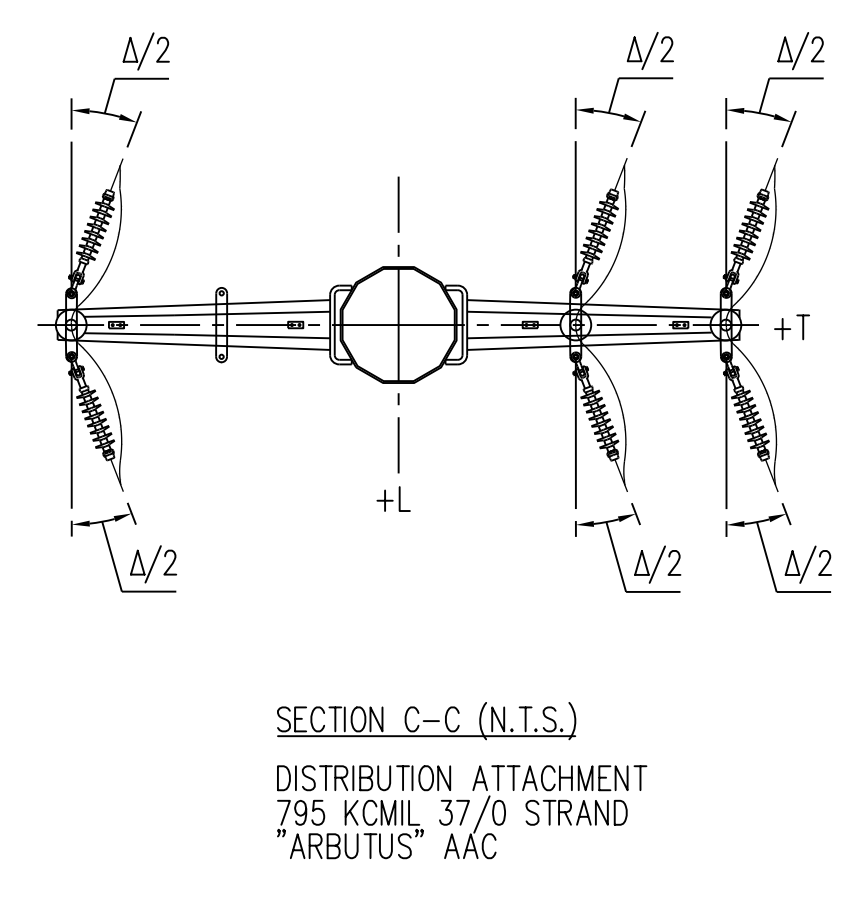
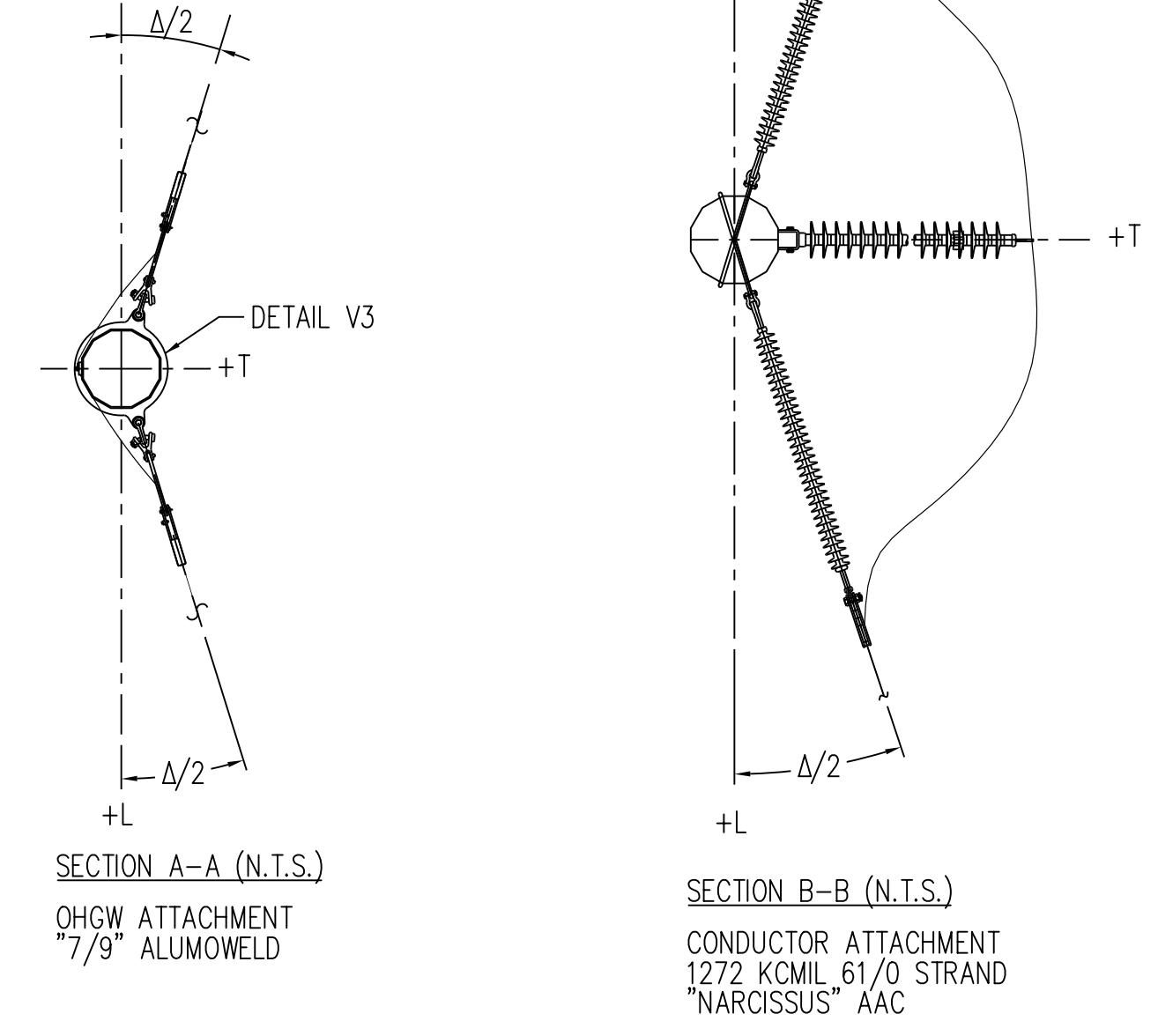
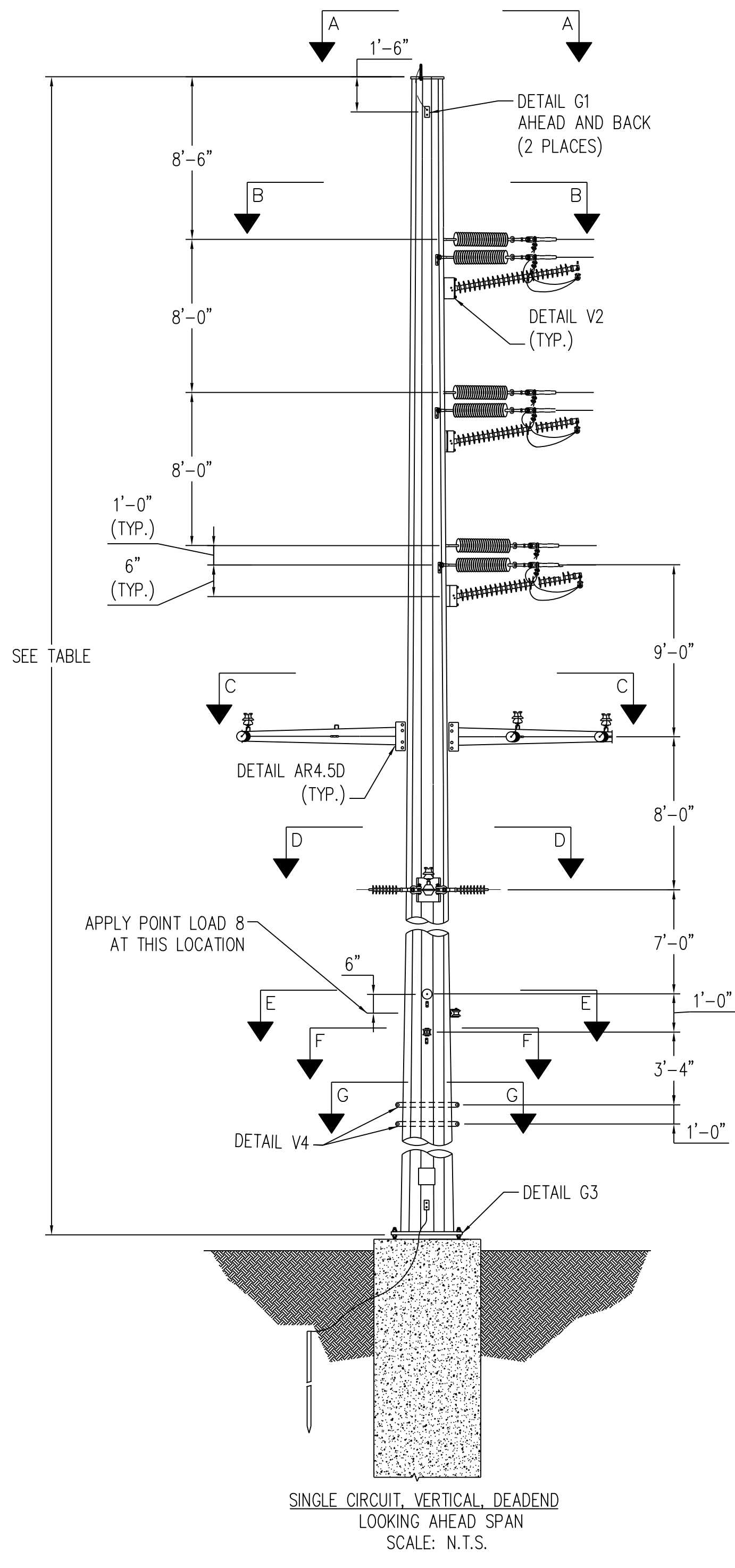

NO.	A
REVISIONS	MT. PLEASANT TO SUGG T-LINE ISSUED FOR BID ENGINEER'S S.E DATE: 12/03/21

CONSTRUCTION NOTE:
 REMOVE OLD WIRE LABELS WITH ORANGE TEXT,
 INSTALL NEW WIRE LABELS WITH GREEN TEXT

ISSUED FOR BID

GREENVILLE UTILITIES
 Greenville, North Carolina

115KV TRANSMISSION LINE
 MT. PLEASANT SUB TO SUGG
 LOAD AND DESIGN
 DEADEND 0'-30" WITH UNDERBUILD

DWN.D. CHAMBLISS DATE 12/03/21 DWG. NO.
 CKD. R. DILLABOUGH APPD. S. ECKMAN DE-30R_STR-22
 SCALE: NONE

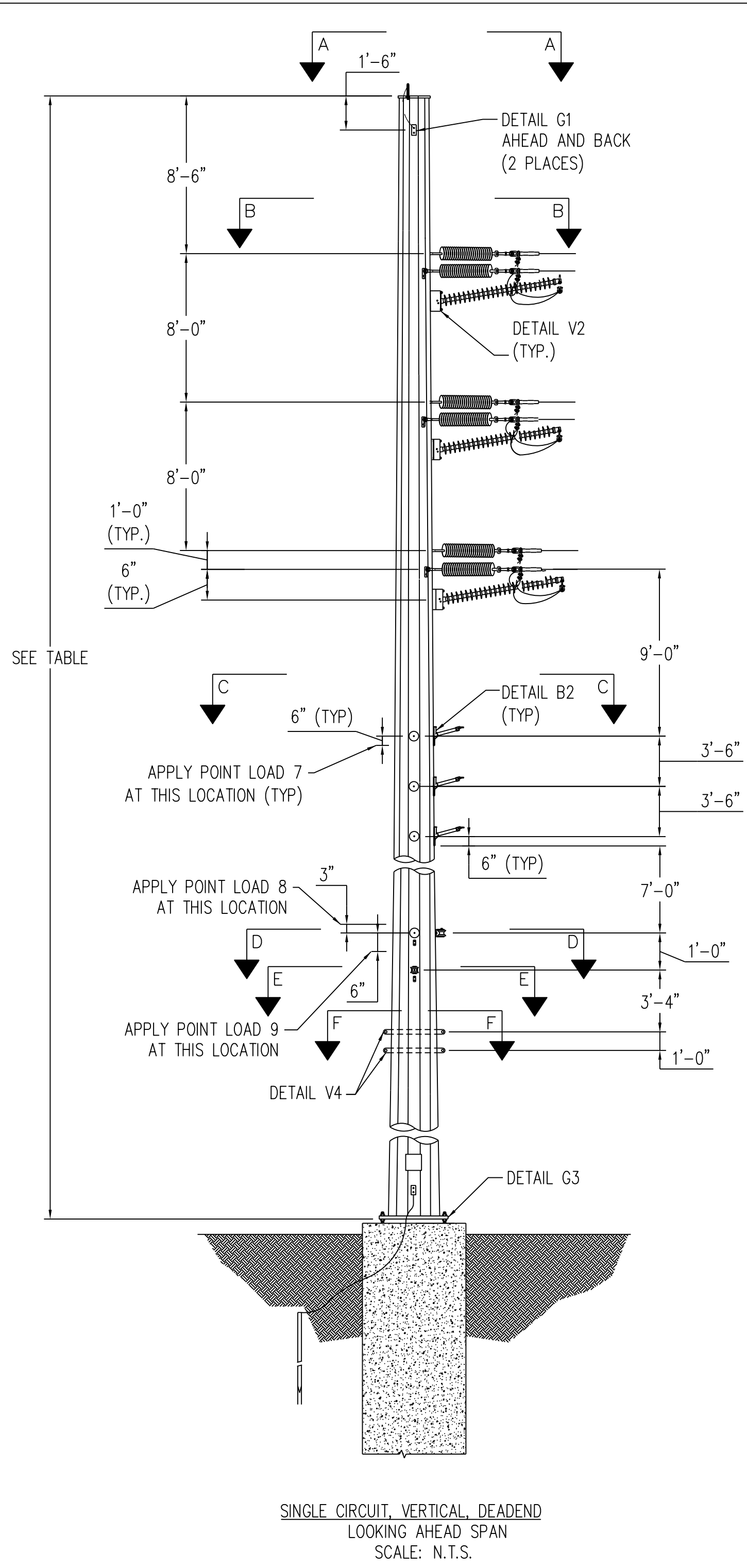

SEE TABLE

STR #	LENGTH (FT)	ANGLE Δ
64	75	22

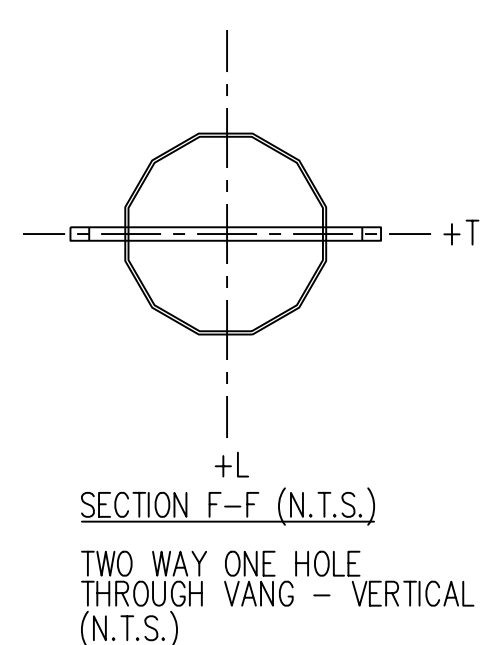
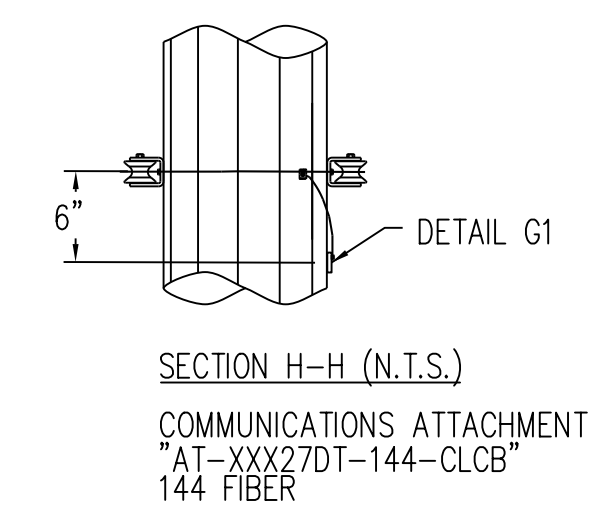
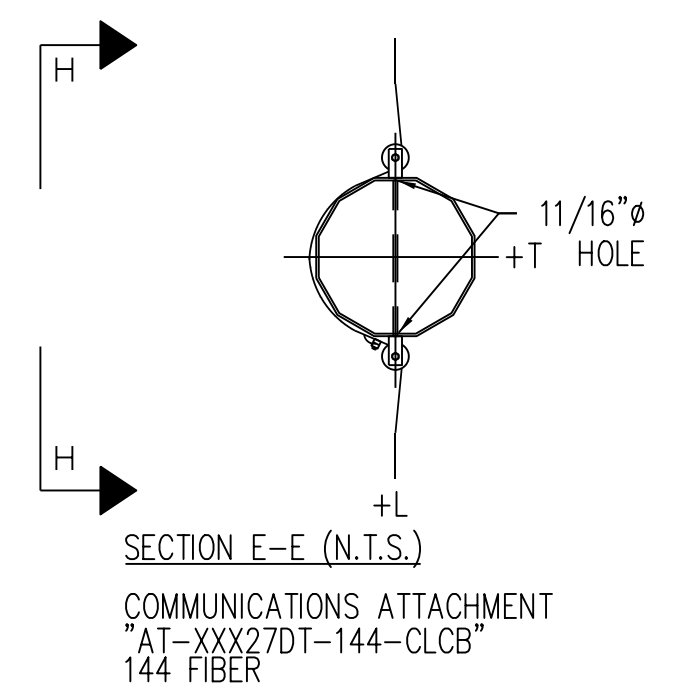
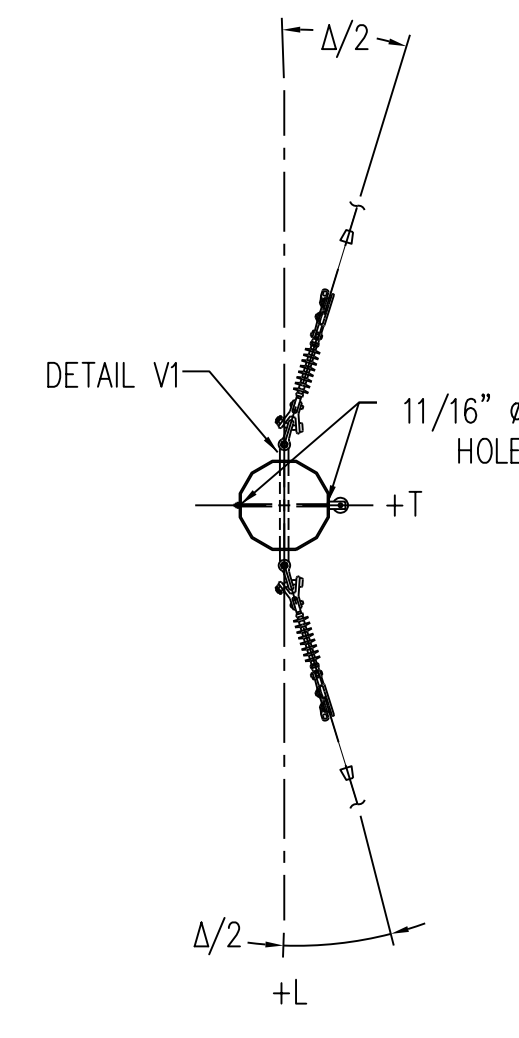
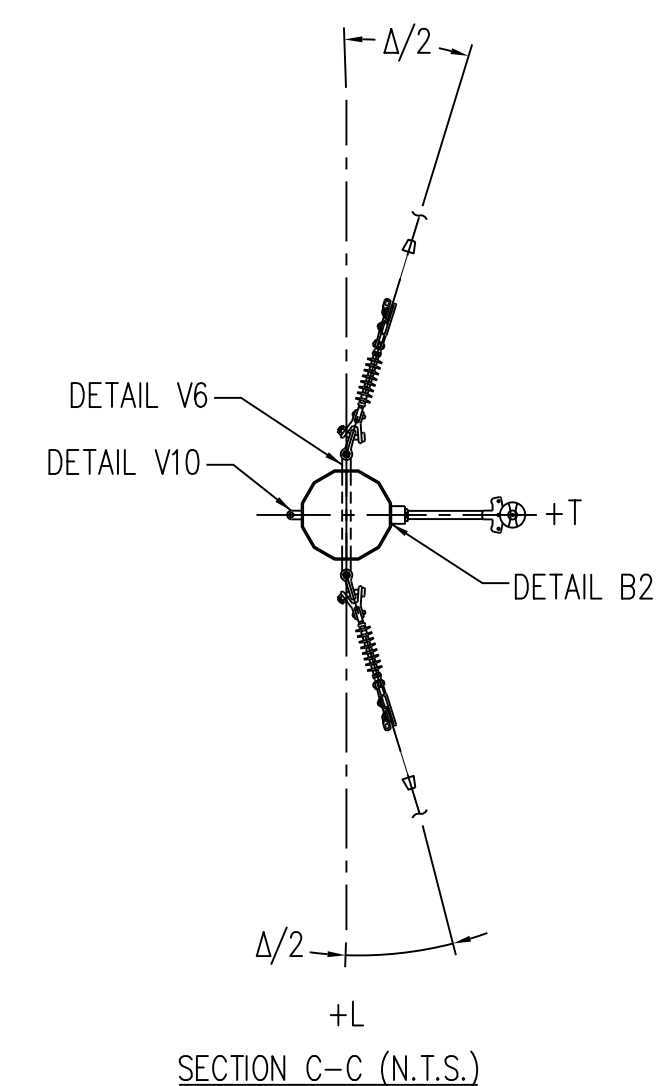
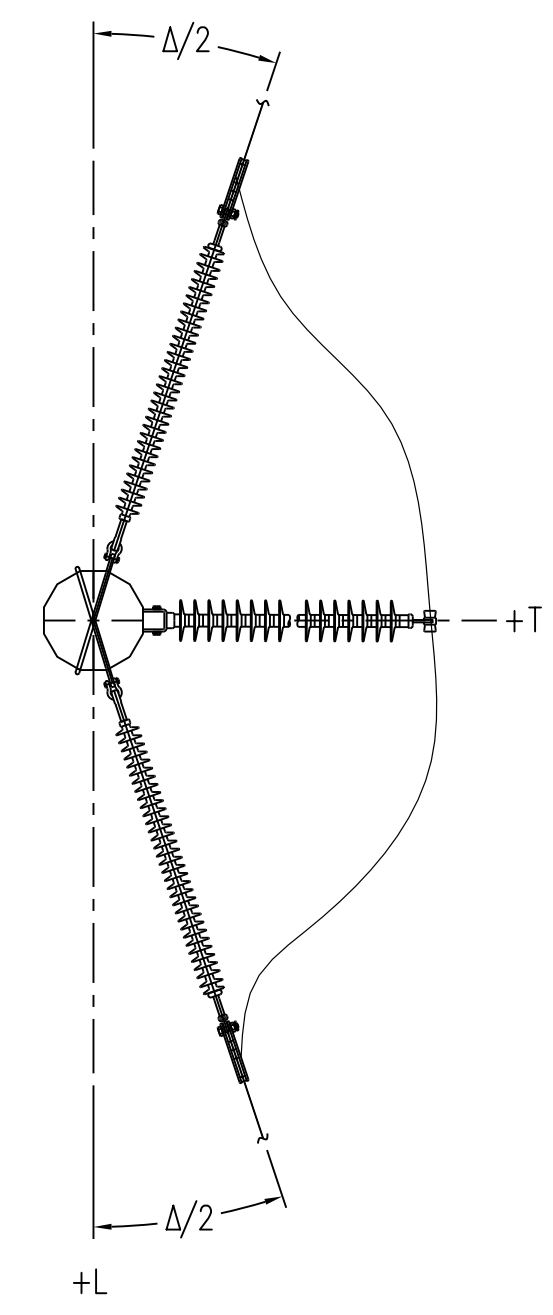
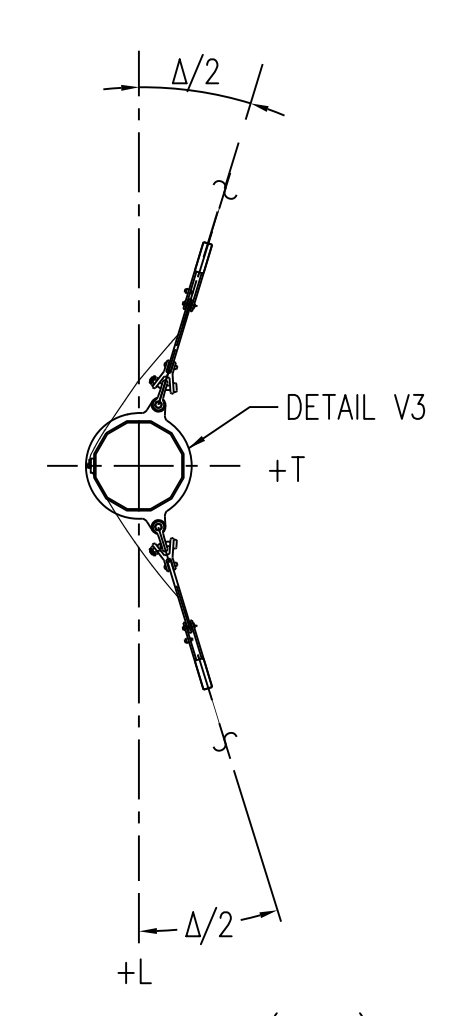

LOADING TABLE								
LOAD	CASE 1	CASE 2	CASE 3	CASE 4	CASE 5	CASE 6	CASE 7	CASE 10
V1	-400	-400	-300	-500	-400	-400	-300	-800
T1	2300	4600	1700	1400	2400	1000	500	1500
L1	-2100	-900	-600	-4700	-2600	-3500	-1200	-2800
V2	6400	11400	4100	3300	5700	2100	1000	5400
L2	-1300	-1300	-1300	-12300	-7400	-9400	-500	-700
V3	-500	-500	-300	-500	-500	-500	-100	-1800
T3	3100	4700	2300	1700	2500	1300	500	2500
L3	-800	-700	-800	-5400	-3500	-4600	-300	-600
V4	-300	-300	-200	-200	-300	-200	-200	-500
T4	1900	3800	1400	1000	2000	800	300	1200
L4	-300	-300	-400	-2600	-1700	-2500	-100	-100
V5	-100	-300	-200	-100	-200	-200	-100	-200
T5	800	1000	800	500	500	500	300	500
L5	-200	-300	-300	-1700	-1600	-1800	-100	-100
V6	-100	-400	-200	-100	-300	-200	-100	-100
T6	900	1300	1000	500	700	500	200	300
L6	-100	-200	-200	-1500	-2000	-2200	-100	-100
V7	300	100	900	300	100	1000	100	200
T7	-2000	-1000	-1600	-2000	-1000	-1600	-600	-2300
L7	-400	-300	-400	-400	-300	-400	-200	-500
V8	300	100	900	300	100	1000	100	200
T8	-2000	-1000	-1600	-2000	-1000	-1600	-600	-2300
L8	-400	-300	-400	-400	-300	-400	-200	-500
V9	200	100	800	300	100	800	100	100
T9	600	700	600	600	700	600	100	300
L9	-300	-300	-300	-300	-300	-300	-100	-200
W(PSF)	10	36.9	4.1	10	36.9	4.1	0	3

ALL LOADS ARE IN LBS, ARE ULTIMATE, AND INCLUDE ALL OVERLOAD FACTORS. "W" REPRESENTS WIND PRESSURE (psf) TO BE APPLIED TO STRUCTURE.

LOAD CASES

- CASE 1 NESM MEDIUM: 15°, .25" ICE, 4 PSF WIND
OLF: L=1.65, T=2.50, V=1.50
- CASE 2 NESM HIGH WIND: 60°, 0" ICE, 120 MPH WIND
OLF: L=1.00, T=1.00, V=1.00
- CASE 3 NESM ICE WITH WIND: 15°, 1" ICE, 40 MPH WIND
OLF: L=1.00, T=1.00, V=1.00
- CASE 4 NESM MEDIUM DEADEND: 15°, .25" ICE, 4 PSF WIND
OLF: L=1.65, T=2.50, V=1.50
- CASE 5 NESM HIGH WIND DEADEND: 60°, 0" ICE, 120 MPH WIND
OLF: L=1.00, T=1.00, V=1.00
- CASE 6 NESM ICE WITH WIND DEADEND: 15°, 1" ICE, 40 MPH WIND
OLF: L=1.00, T=1.00, V=1.00
- CASE 7 DEFLECTION: 60 DEGREES, NO ICE, NO WIND, FINAL
OLF: L=1.00, T=1.00, V=1.00
- CASE 10 STRINGING: -20°, 0" ICE, 2 PSF WIND
OLF: L=1.50, T=1.50, V=1.50

WIRE DATA

OHGW: "7#9" ALUMOWELD
115KV: 1272 KCMIL 61/0 STRAND "NARCISSUS" AAC
12.47KV: 336.4 KCMIL 18/1 STRAND "MERLIN" ACSR
DISTRIBUTION NEUTRAL: 1/0 6/1 STRAND "RAVEN" ACSR
ADSS: "AT-XXX27DT-144-CLCB" 144 FIBER

NOTES:

- ALL STATED LOADS ARE ULTIMATE VALUES AND INCLUDE OVERLOAD FACTORS AND INSULATOR WEIGHT.
- STRUCTURE AND ATTACHMENTS SHALL BE DESIGNED FOR THE SIMULTANEOUS APPLICATION OF DEAD LOAD, WIND ON THE STRUCTURE, AND WIRE LOADS FOR EACH LOADING CASE.
- STRUCTURE SHALL BE DESIGNED SELF SUPPORTING, GUYS ARE NOT PERMITTED. STRUCTURE SHALL MEET ALL TECHNICAL REQUIREMENTS OF THE STEEL POLE SPECIFICATIONS.
- WIND PRESSURES SHOWN ON LOAD WORKSHEET ARE BASED ON A SHAPE FACTOR OF 1.0.
- FABRICATOR MAY PROPOSE STRUCTURAL DETAILS DIFFERENT THAN THOSE SHOWN TO SIMPLIFY FABRICATION. VARIATIONS SHALL BE SUBMITTED TO ENGINEER IN WRITING.
- MINIMUM VANG PLATE THICKNESS = 1/2".
- WIND SHALL BE APPLIED IN THE DIRECTION WHICH RESULTS IN THE MOST SEVERE EFFECT.
- THE DEFLECTION AT THE POLE TOP SHALL BE LIMITED TO 1.5% OF THE POLE HEIGHT UNDER THE DEFLECTION CASE. POLES MAY BE CAMBERED TO FALL WITHIN THE DESIGN LIMIT.
- MAXIMUM DEFLECTION AT TOP OF THE STRUCTURE SHALL BE LIMITED TO 10% OF STRUCTURE HEIGHT UNDER ALL LOAD CASES WITH THE EXCEPTION TO THE 60° NO WIND LOAD CASE.
- POLE DESIGN AND FABRICATION SHALL INCLUDE PROVISIONS FOR A SLIP JOINT TO LIMIT LOWEST POLE SEGMENT EXTENSION ABOVE GRADE TO 12'-0" MAXIMUM.
- ALL STRUCTURES SHALL BE GALVANIZED STEEL.
- ORIENT SINGLE SIDED VANGS FOR HARDWARE SHOWN ON DRAWINGS.
- MANUFACTURER SHALL APPLY POINT LOADS NECESSARY TO CREATE THE MOST SEVERE EFFECTS ON ALL MEMBERS INCLUDING ARMS, POLES, BASE PLATES, ETC.

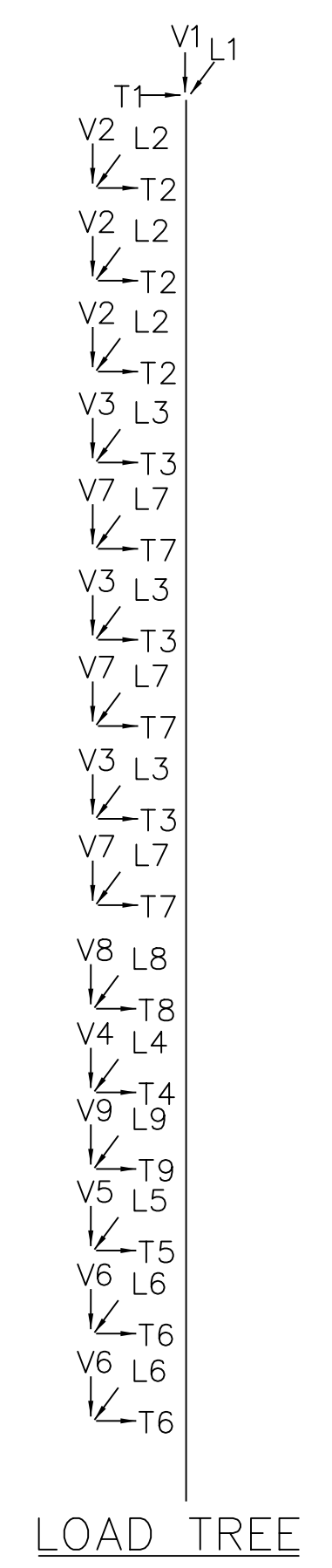

NO.	A
REVISIONS	MT. PLEASANT TO SUGG T-LINE ISSUED FOR BID ENGINEERS: S.E DATE: 12/03/21

CONSTRUCTION NOTE:
REMOVE OLD WIRE LABELS WITH ORANGE TEXT,
INSTALL NEW WIRE LABELS WITH GREEN TEXT

ISSUED FOR BID

GREENVILLE UTILITIES
Greenville, North Carolina

115KV TRANSMISSION LINE
MT. PLEASANT SUB TO SUGG
LOAD AND DESIGN
DEADEND 0'-30" WITH UNDERBUILD

DWIND. CHAMBLISS DATE 12/03/21 DWG. NO.
CKD. R. DILLABOUGH APPD. S. ECKMAN DE-30R_STR-64
SCALE: NONE

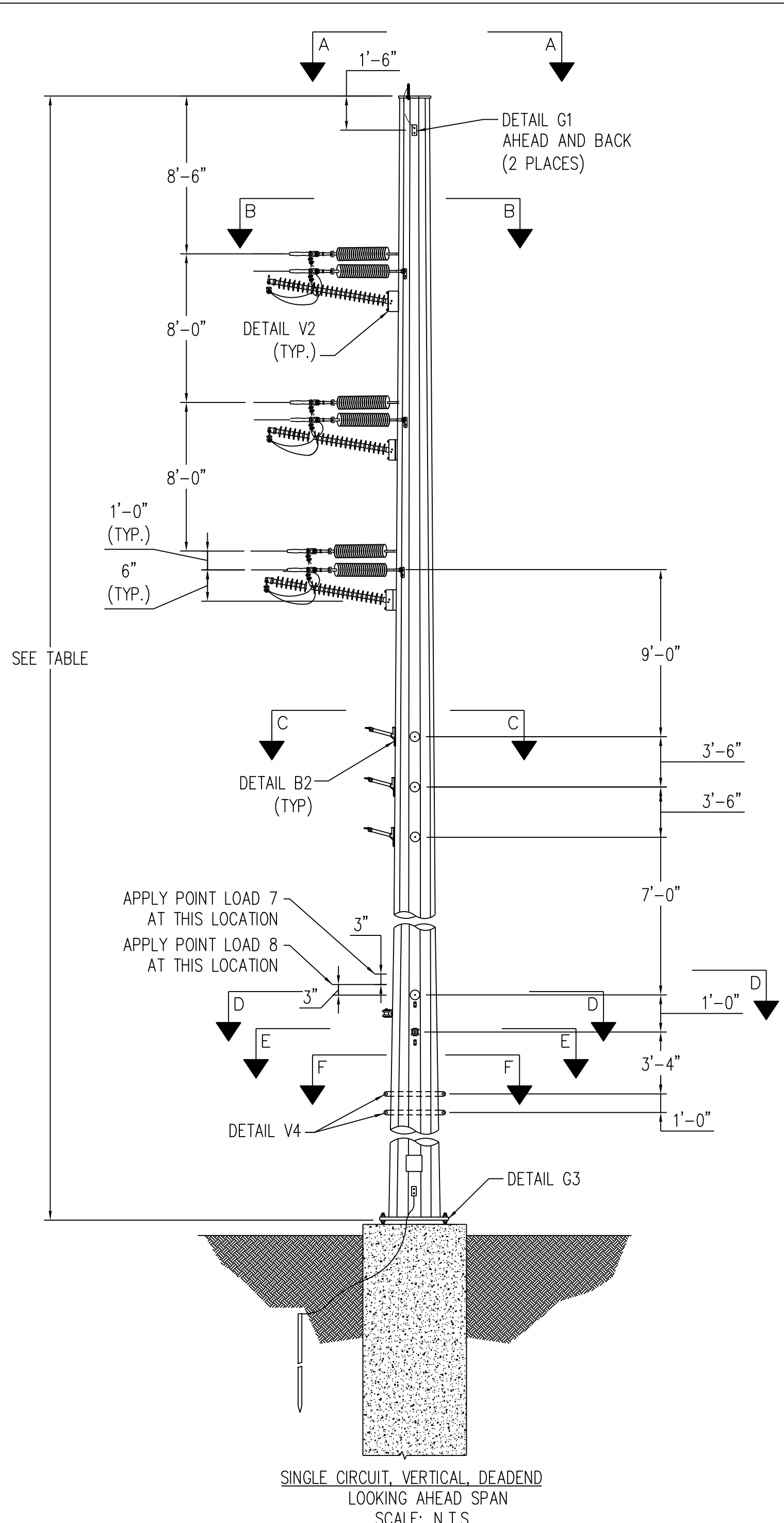

STR #	LENGTH (FT)	ANGLE Δ
63	105	-38

LOADING TABLE									
LOAD	CASE 1	CASE 2	CASE 3	CASE 4	CASE 5	CASE 6	CASE 7	CASE 10	
V1	700	500	1200	600	500	800	400	900	
T1	-4100	-5900	-3200	-2100	-3100	-1900	-1100	-3200	
L1	200	600	1100	4600	3000	4500	300	700	
V2	2400	1500	2700	1900	1200	1800	900	2900	
T2	-10700	-15400	-7700	-6000	-8500	-4500	-2000	-9700	
L2	2900	3600	3300	13600	9600	11200	1300	1200	
V3	900	700	1400	700	500	900	300	3500	
T3	-4600	-6300	-3700	-2500	-3500	-2200	-700	-3500	
L3	1200	1600	1700	5700	4300	5400	400	1100	
V4	500	400	1000	300	300	600	200	500	
T4	-2800	-4800	-2300	-1500	-2600	-1400	-400	-1700	
L4	600	700	1000	2800	2100	3000	100	300	
V5	500	300	1000	300	300	600	200	300	
T5	-1300	-1600	-1500	-800	-1000	-900	-300	-600	
L5	300	600	700	1600	1900	2100	300	400	
V6	600	500	1300	400	400	700	200	400	
T6	-1400	-2200	-1700	-800	-1300	-1000	-200	-500	
L6	100	400	400	1500	2300	2300	100	200	
V7	600	200	2300	700	200	2500	200	200	
T7	-100	-200	100	-100	-200	100	100	-100	
L7	200	300	400	200	300	400	100	100	
W/PSF	10	36.9	4.1	10	36.9	4.1	0	3	

ALL LOADS ARE IN LBS, ARE ULTIMATE, AND INCLUDE ALL OVERLOAD FACTORS. "W" REPRESENTS WIND PRESSURE (psf) TO BE APPLIED TO STRUCTURE.

LOAD CASES

- CASE 1 NESIC MEDIUM: 15°, .25" ICE, 4 PSF WIND
OLF: L=1.65, T=2.50, V=1.50
- CASE 2 NESIC HIGH WIND: 60°, 0" ICE, 120 MPH WIND
OLF: L=1.00, T=1.00, V=1.00
- CASE 3 NESIC ICE WITH WIND: 15°, 1" ICE, 40 MPH WIND
OLF: L=1.00, T=1.00, V=1.00
- CASE 4 NESIC MEDIUM DEADEND: 15°, .25" ICE, 4 PSF WIND
OLF: L=1.65, T=2.50, V=1.50
- CASE 5 NESIC HIGH DEADEND: 60°, 0" ICE, 120 MPH WIND
OLF: L=1.00, T=1.00, V=1.00
- CASE 6 NESIC ICE WITH WIND DEADEND: 15°, 1" ICE, 40 MPH WIND
OLF: L=1.00, T=1.00, V=1.00
- CASE 7 DEFLECTION: 60 DEGREES, NO ICE, NO WIND, FINAL
OLF: L=1.00, T=1.00, V=1.00
- CASE 10 STRINGING: -20°, 0" ICE, 2 PSF WIND
OLF: L=1.50, T=1.50, V=1.50

WIRE DATA

OHGW: "7#9" ALUMOWELD
115KV: 1272 KCMIL 61/0 STRAND "NARCISSUS" AAC
12.47KV: 336.4 KCMIL 18/1 STRAND "MERLIN" ACSR
DISTRIBUTION NEUTRAL: 1/0 6/1 STRAND "RAVEN" ACSR
ADSS: "AT-XXX27DT-144-CLCB" 144 FIBER

NOTES:

- ALL STATED LOADS ARE ULTIMATE VALUES AND INCLUDE OVERLOAD FACTORS AND INSULATOR WEIGHT.
- STRUCTURE AND ATTACHMENTS SHALL BE DESIGNED FOR THE SIMULTANEOUS APPLICATION OF DEAD LOAD, WIND ON THE STRUCTURE, AND WIRE LOADS FOR EACH LOADING CASE.
- STRUCTURE SHALL BE DESIGNED SELF SUPPORTING, GUYS ARE NOT PERMITTED. STRUCTURE SHALL MEET ALL TECHNICAL REQUIREMENTS OF THE STEEL POLE SPECIFICATIONS.
- WIND PRESSURES SHOWN ON LOAD WORKSHEET ARE BASED ON A SHAPE FACTOR OF 1.0.
- FABRICATOR MAY PROPOSE STRUCTURAL DETAILS DIFFERENT THAN THOSE SHOWN TO SIMPLIFY FABRICATION. VARIATIONS SHALL BE SUBMITTED TO ENGINEER IN WRITING.
- MINIMUM VANG PLATE THICKNESS = 1/2".
- WIND SHALL BE APPLIED IN THE DIRECTION WHICH RESULTS IN THE MOST SEVERE EFFECT.
- THE DEFLECTION AT THE POLE TOP SHALL BE LIMITED TO 1.5% OF THE POLE HEIGHT UNDER THE DEFLECTION CASE. POLES MAY BE CAMBERED TO FALL WITHIN THE DESIGN LIMIT.
- MAXIMUM DEFLECTION AT TOP OF THE STRUCTURE SHALL BE LIMITED TO 10% OF STRUCTURE HEIGHT UNDER ALL LOAD CASES WITH THE EXCEPTION TO THE 60° NO WIND LOAD CASE.
- POLE DESIGN AND FABRICATION SHALL INCLUDE PROVISIONS FOR A SLIP JOINT TO LIMIT LOWEST POLE SEGMENT EXTENSION ABOVE GRADE TO 12'-0" MAXIMUM.
- ALL STRUCTURES SHALL BE GALVANIZED STEEL.
- ORIENT SINGLE SIDED VANGS FOR HARDWARE SHOWN ON DRAWINGS.
- MANUFACTURER SHALL APPLY POINT LOADS NECESSARY TO CREATE THE MOST SEVERE EFFECTS ON ALL MEMBERS INCLUDING ARMS, POLES, BASE PLATES, ETC.

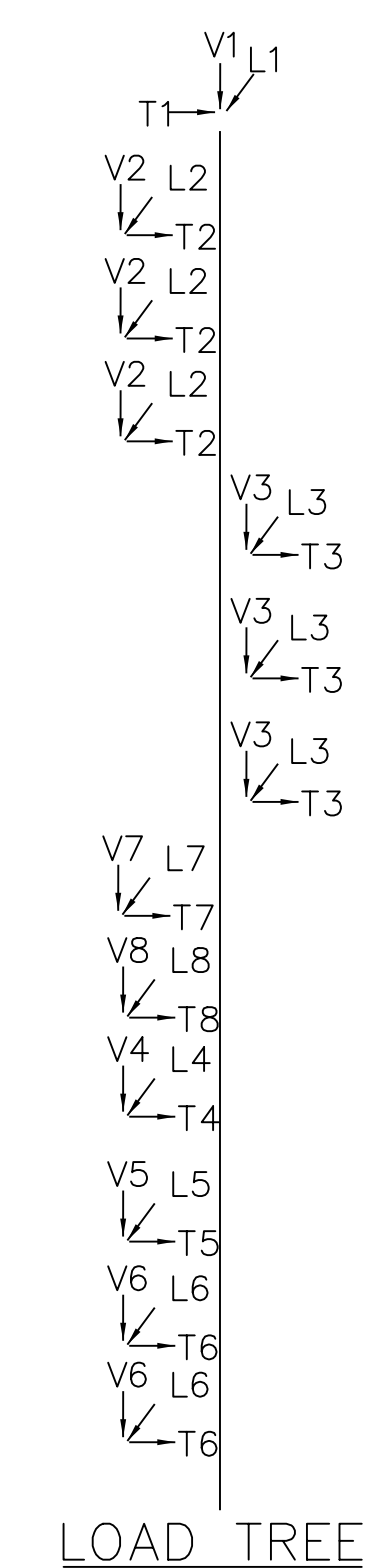

CONSTRUCTION NOTE:
REMOVE OLD WIRE LABELS WITH ORANGE TEXT,
INSTALL NEW WIRE LABELS WITH GREEN TEXT

NO.	A
REVISIONS	MT. PLEASANT TO SUGG T-LINE ISSUED FOR BID ENGINEERS: S.E DATE: 12/03/21

ISSUED FOR BID

GREENVILLE UTILITIES
Greenville, North Carolina

115KV TRANSMISSION LINE
MT. PLEASANT SUB TO SUGG
LOAD AND DESIGN
DEADEND 30'-60' WITH UNDERBUILD

DWIND. CHAMBLISS DATE 12/03/21 DWG. NO.
CKD. R. DILLABOUGH APPD. S. ECKMAN DE-60L_STR-63
SCALE: NONE

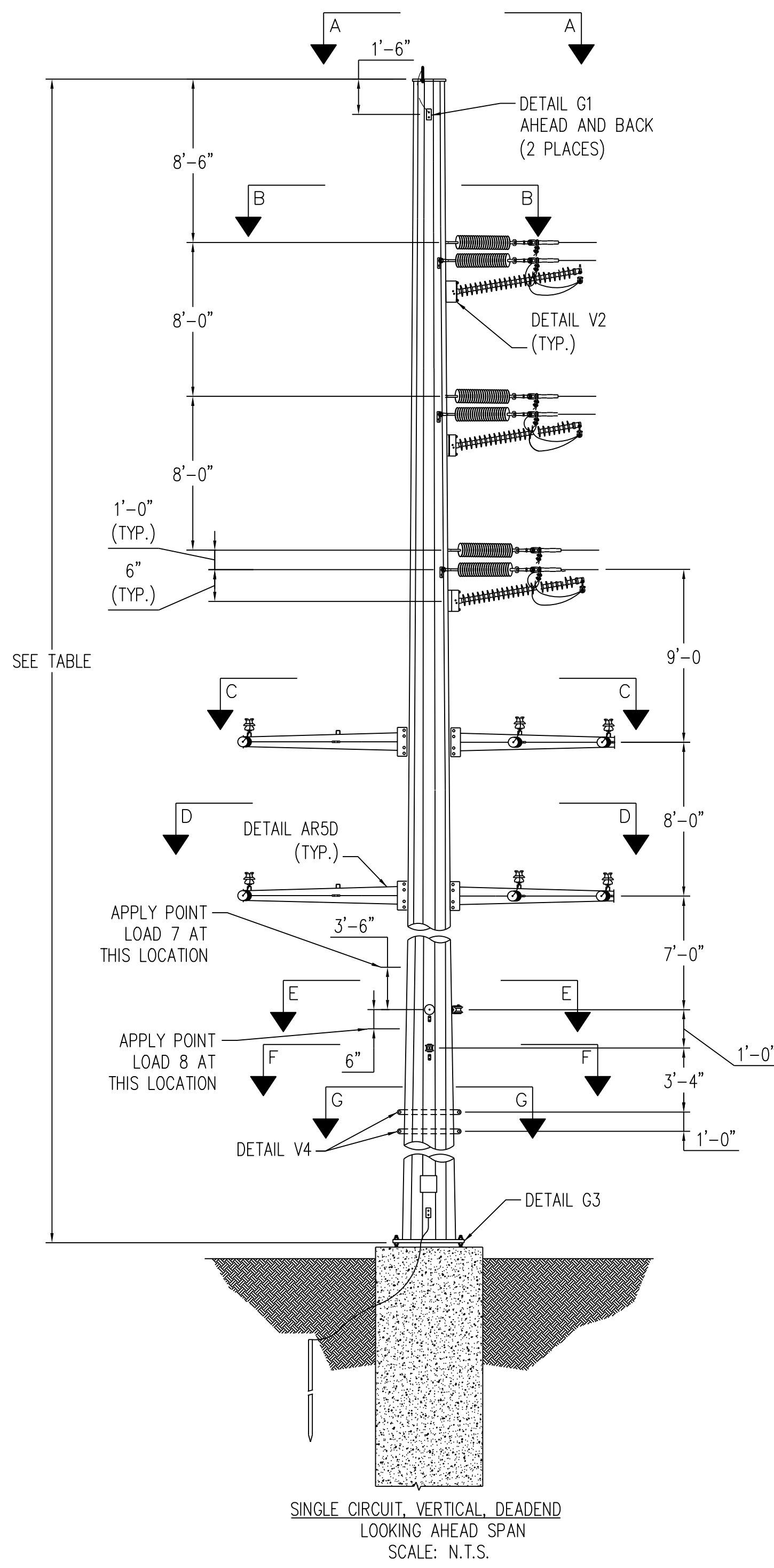

SEE TABLE

SINGLE CIRCUIT, VERTICAL, DEADEND
LOOKING AHEAD SPAN
SCALE: N.T.S.

STR #	LENGTH (FT)	ANGLE Δ
6	80	38

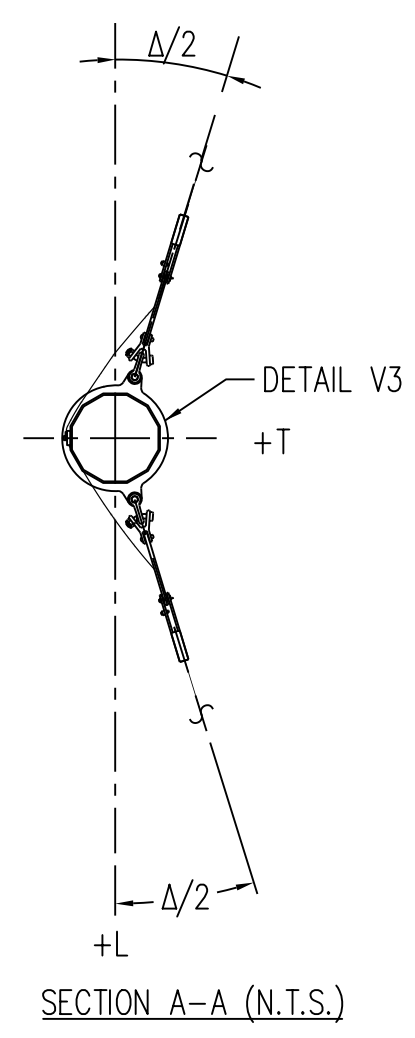

SECTION A-A (N.T.S.)
OHGW ATTACHMENT
7/9" ALUMOWELD

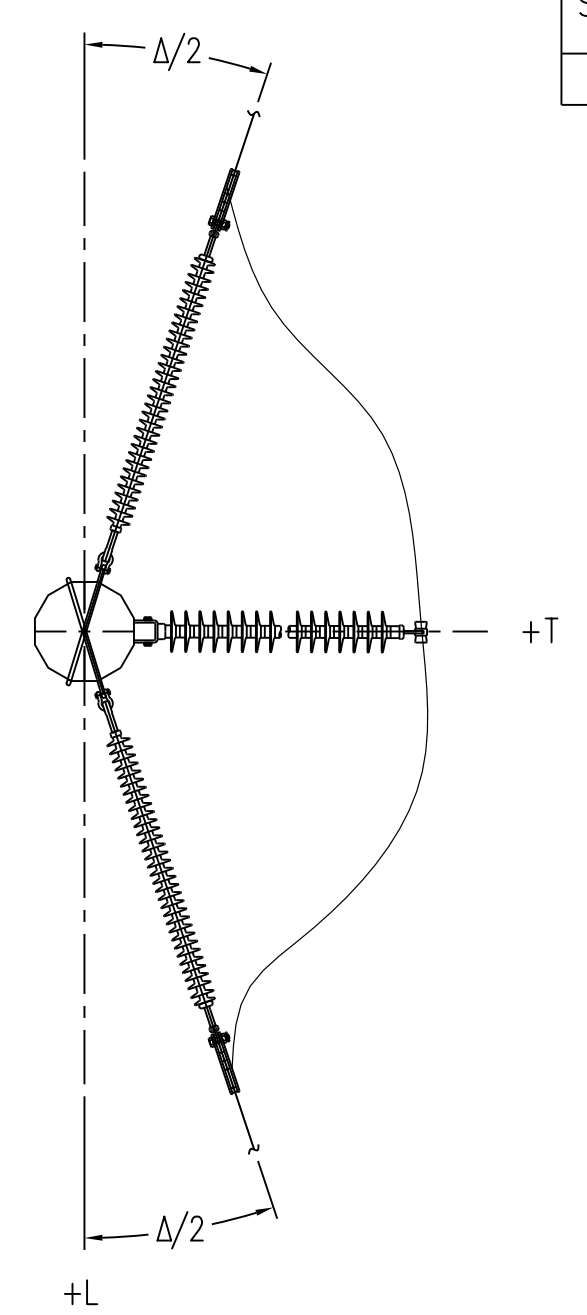

SECTION B-B (N.T.S.)
CONDUCTOR ATTACHMENT
1272 KCMIL 61/0 STRAND
'NARCISSUS' AAC

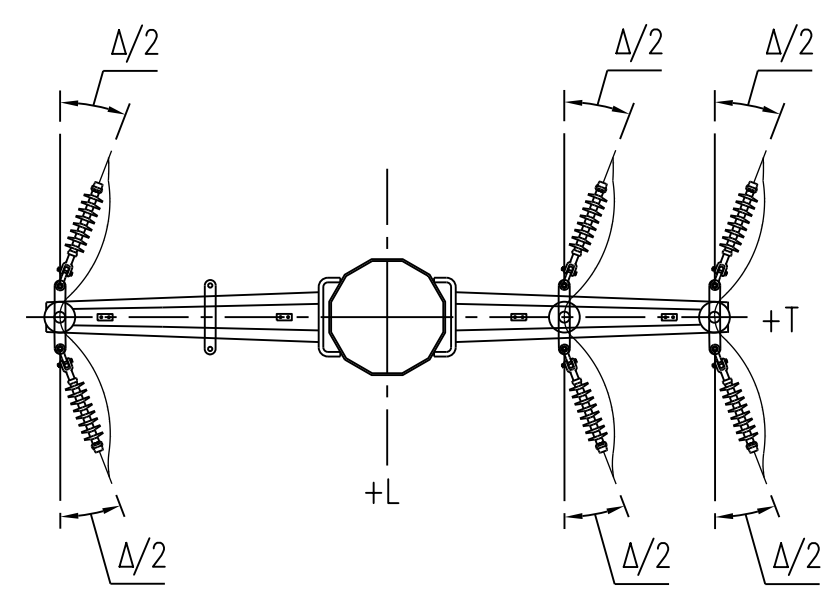

SECTION C-C, D-D (N.T.S.)
DISTRIBUTION ATTACHMENT
795 KCMIL 37/0 STRAND
'ARBUTUS' AAC

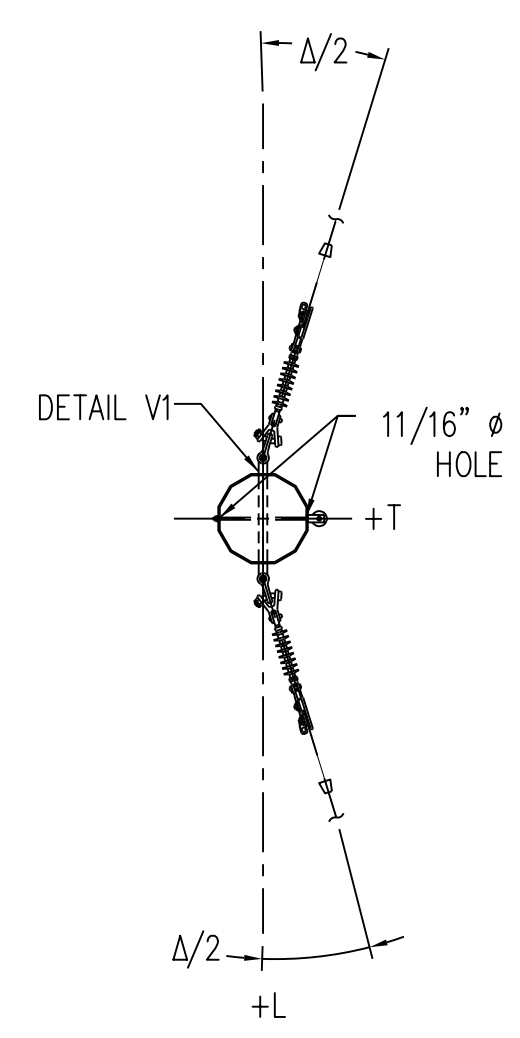

SECTION E-E (N.T.S.)
NEUTRAL ATTACHMENT
336.4 KCMIL 18/1 STRAND
'MERLIN' ACSR

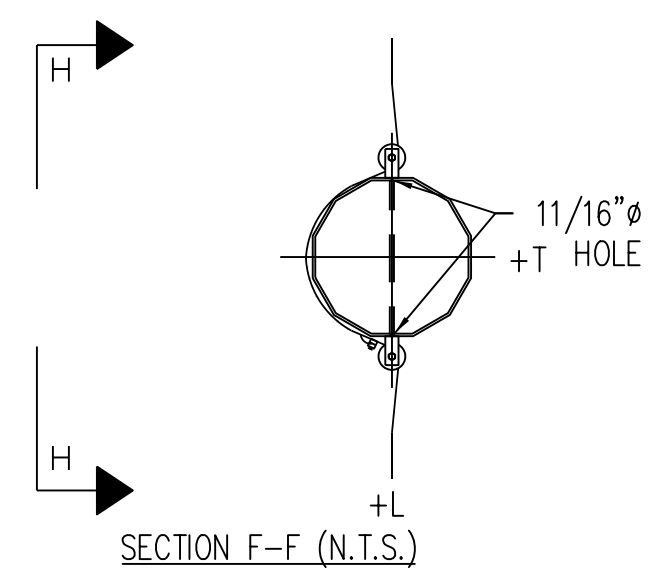

SECTION F-F (N.T.S.)
COMMUNICATIONS ATTACHMENT
'AT-XXX27DT-144-CLCB'
144 FIBER

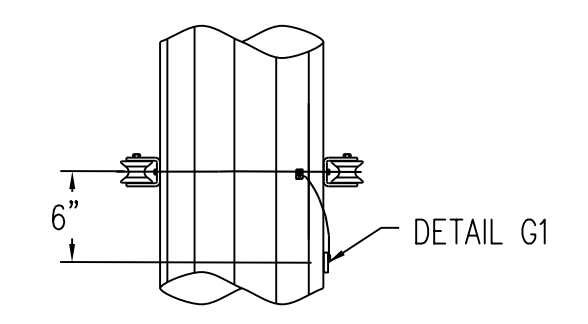

SECTION H-H (N.T.S.)
COMMUNICATIONS ATTACHMENT
'AT-XXX27DT-144-CLCB'
144 FIBER

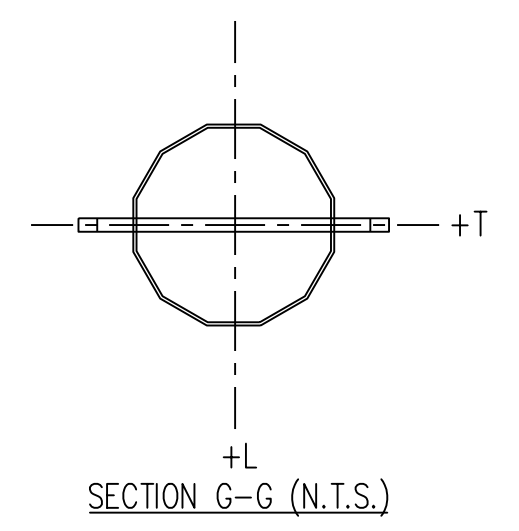

SECTION G-G (N.T.S.)
TWO WAY ONE HOLE
THROUGH VANG - VERTICAL
(N.T.S.)

LOAD	LOADING TABLE									
	CASE 1	CASE 2	CASE 3	CASE 4	CASE 5	CASE 6	CASE 7	CASE 10		
V1	-100	-200	200	-200	-200	300	-100	300		
T1	3400	5300	2700	2000	2800	1400	800	2500		
L1	1800	700	400	4600	2600	3400	1100	2500		
V2	-300	-300	200	-500	-400	400	-100	800		
T2	10300	13900	7100	5500	7400	4000	1900	9700		
L2	1500	1700	1700	12300	7700	9600	700	700		
V3	-300	-400	100	-300	-300	200	-100	3600		
T3	6300	7000	4700	3400	3700	2600	1200	5800		
L3	1100	1200	1300	8400	5500	6800	500	1200		
V4	-300	-300	100	-300	-300	200	-100	3500		
T4	6200	6700	4600	3300	3500	2500	1100	5800		
L4	800	800	800	8000	5000	6400	300	1100		
V4	-200	-300	200	-200	-200	200	-100	400		
T4	4200	5300	3300	2200	2800	1800	700	3600		
L4	300	600	700	4900	3300	4500	200	200		
V5	-100	-100	400	-100	-100	300	-100	100		
T5	1300	1400	1300	700	800	700	500	700		
L5	300	400	400	1700	1700	1800	100	100		
V6	-200	-100	500	-200	-100	400	-100	100		
T6	1300	1900	1600	700	1000	900	300	500		
L6	100	200	200	1500	2000	2200	100	100		
V7	400	100	1100	400	100	1200	100	200		
T7	-1200	-600	-1000	-1200	-600	-1000	-400	-1300		
L7	1900	1100	1700	1900	1100	1700	500	2000		
V8	400	100	1100	400	100	1200	100	200		
T8	-1200	-600	-1000	-1200	-600	-1000	-400	-1300		
L8	1900	1100	1700	1900	1100	1700	500	2000		
W(P5F)	10	36.9	4.1	10	36.9	4.1	0	3		

ALL LOADS ARE IN LBS, ARE ULTIMATE, AND INCLUDE ALL OVERLOAD FACTORS. "W" REPRESENTS WIND PRESSURE (psf) TO BE APPLIED TO STRUCTURE.

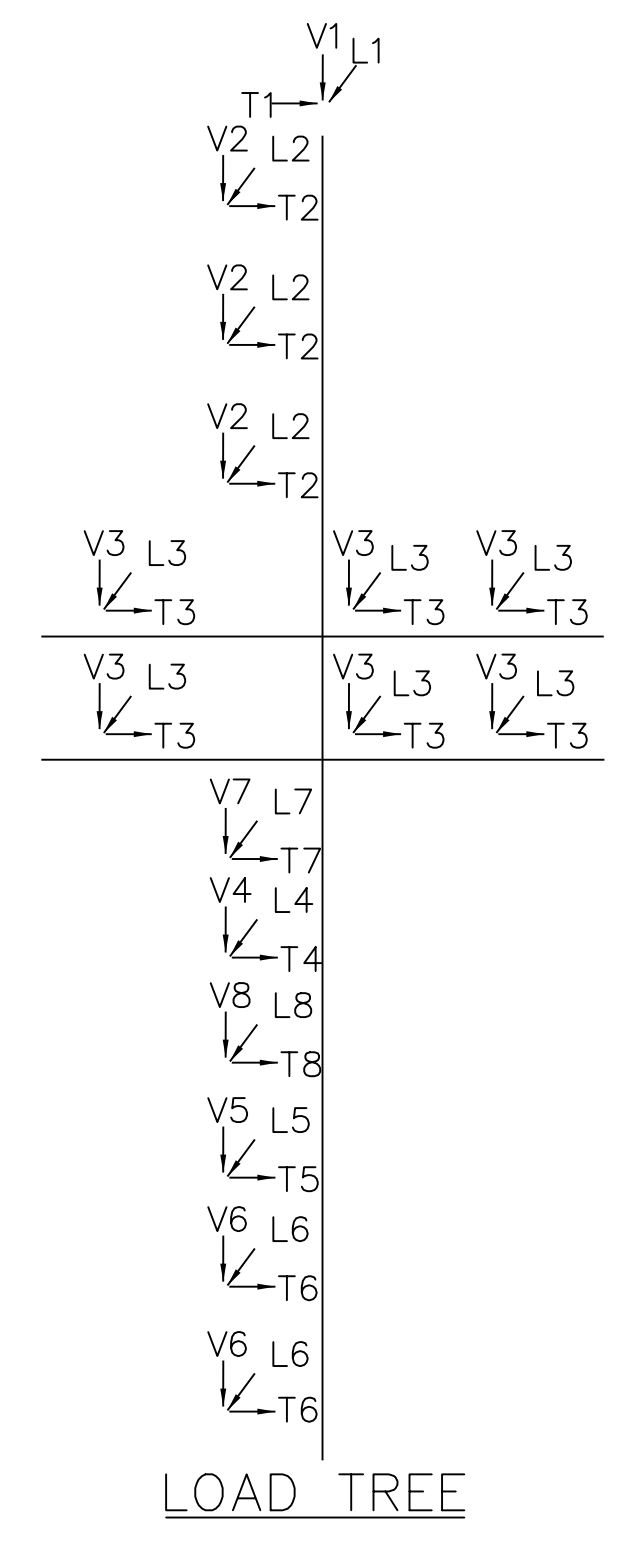

LOAD CASES

- CASE 1 NESC MEDIUM: 15°, .25" ICE, 4 PSF WIND
OLF: L=1.65, T=2.50, V=1.50
- CASE 2 NESC HIGH WIND: 60°, 0" ICE, 120 MPH WIND
OLF: L=1.00, T=1.00, V=1.00
- CASE 3 NESC ICE WITH WIND: 15°, 1" ICE, 40 MPH WIND
OLF: L=1.00, T=1.00, V=1.00
- CASE 4 NESC MEDIUM DEADEND: 15°, .25" ICE, 4 PSF WIND
OLF: L=1.65, T=2.50, V=1.50
- CASE 5 NESC HIGH WIND DEADEND: 60°, 0" ICE, 120 MPH WIND
OLF: L=1.00, T=1.00, V=1.00
- CASE 6 NESC ICE WITH WIND DEADEND: 15°, 1" ICE, 40 MPH WIND
OLF: L=1.00, T=1.00, V=1.00
- CASE 7 DEFLECTION: 60 DEGREES, NO ICE, NO WIND, FINAL
OLF: L=1.00, T=1.00, V=1.00
- CASE 10 STRINGING: -20°, 0" ICE, 2 PSF WIND
OLF: L=1.50, T=1.50, V=1.50

WIRE DATA

OHGW: "7#9" ALUMOWELD
115KV: 1272 KCMIL 61/0 STRAND "NARCISSUS" AAC
12.47KV: 795 KCMIL 37/0 STRAND "ARBUTUS" AAC
DISTRIBUTION NEUTRAL: 336.4 KCMIL 18/1 STRAND "MERLIN" ACSR
ADSS: "AT-XXX27DT-144-CLCB" 144 FIBER

NOTES:

- ALL STATED LOADS ARE ULTIMATE VALUES AND INCLUDE OVERLOAD FACTORS AND INSULATOR WEIGHT.
- STRUCTURE AND ATTACHMENTS SHALL BE DESIGNED FOR THE SIMULTANEOUS APPLICATION OF DEAD LOAD, WIND ON THE STRUCTURE, AND WIRE LOADS FOR EACH LOADING CASE.
- STRUCTURE SHALL BE DESIGNED SELF SUPPORTING, GUYS ARE NOT PERMITTED. STRUCTURE SHALL MEET ALL TECHNICAL REQUIREMENTS OF THE STEEL POLE SPECIFICATIONS.
- WIND PRESSURES SHOWN ON LOAD WORKSHEET ARE BASED ON A SHAPE FACTOR OF 1.0.
- FABRICATOR MAY PROPOSE STRUCTURAL DETAILS DIFFERENT THAN THOSE SHOWN TO SIMPLIFY FABRICATION. VARIATIONS SHALL BE SUBMITTED TO ENGINEER IN WRITING.
- MINIMUM VANG PLATE THICKNESS = 1/2".
- WIND SHALL BE APPLIED IN THE DIRECTION WHICH RESULTS IN THE MOST SEVERE EFFECT.
- THE DEFLECTION AT THE POLE TOP SHALL BE LIMITED TO 1.5% OF THE POLE HEIGHT UNDER THE DEFLECTION CASE. POLES MAY BE CAMBERED TO FALL WITHIN THE DESIGN LIMIT.
- MAXIMUM DEFLECTION AT TOP OF THE STRUCTURE SHALL BE LIMITED TO 10% OF STRUCTURE HEIGHT UNDER ALL LOAD CASES WITH THE EXCEPTION TO THE 60° NO WIND LOAD CASE.
- POLE DESIGN AND FABRICATION SHALL INCLUDE PROVISIONS FOR A SLIP JOINT TO LIMIT LOWEST POLE SEGMENT EXTENSION ABOVE GRADE TO 12"-0" MAXIMUM.
- ALL STRUCTURES SHALL BE GALVANIZED STEEL.
- ORIENT SINGLE SIDED VANGS FOR HARDWARE SHOWN ON DRAWINGS.
- MANUFACTURER SHALL APPLY POINT LOADS NECESSARY TO CREATE THE MOST SEVERE EFFECTS ON ALL MEMBERS INCLUDING ARMS, POLES, BASE PLATES, ETC.

NO.	A
REVISIONS	MT. PLEASANT TO SUGG T-LINE ISSUED FOR BID ENGINEERS: S.E DATE: 12/03/21

CONSTRUCTION NOTE:
REMOVE OLD WIRE LABELS WITH ORANGE TEXT,
INSTALL NEW WIRE LABELS WITH GREEN TEXT

ISSUED FOR BID

GREENVILLE UTILITIES
Greenville, North Carolina

115KV TRANSMISSION LINE
MT. PLEASANT SUB TO SUGG
LOAD AND DESIGN
DEADEND 30"-60" WITH UNDERBUILD

DWIND, CHAMBLISS DATE 12/03/21 DWG. NO.
CKD, R. DILLABOUGH APPD. S. ECKMAN DE-60R_STR-6
SCALE: NONE

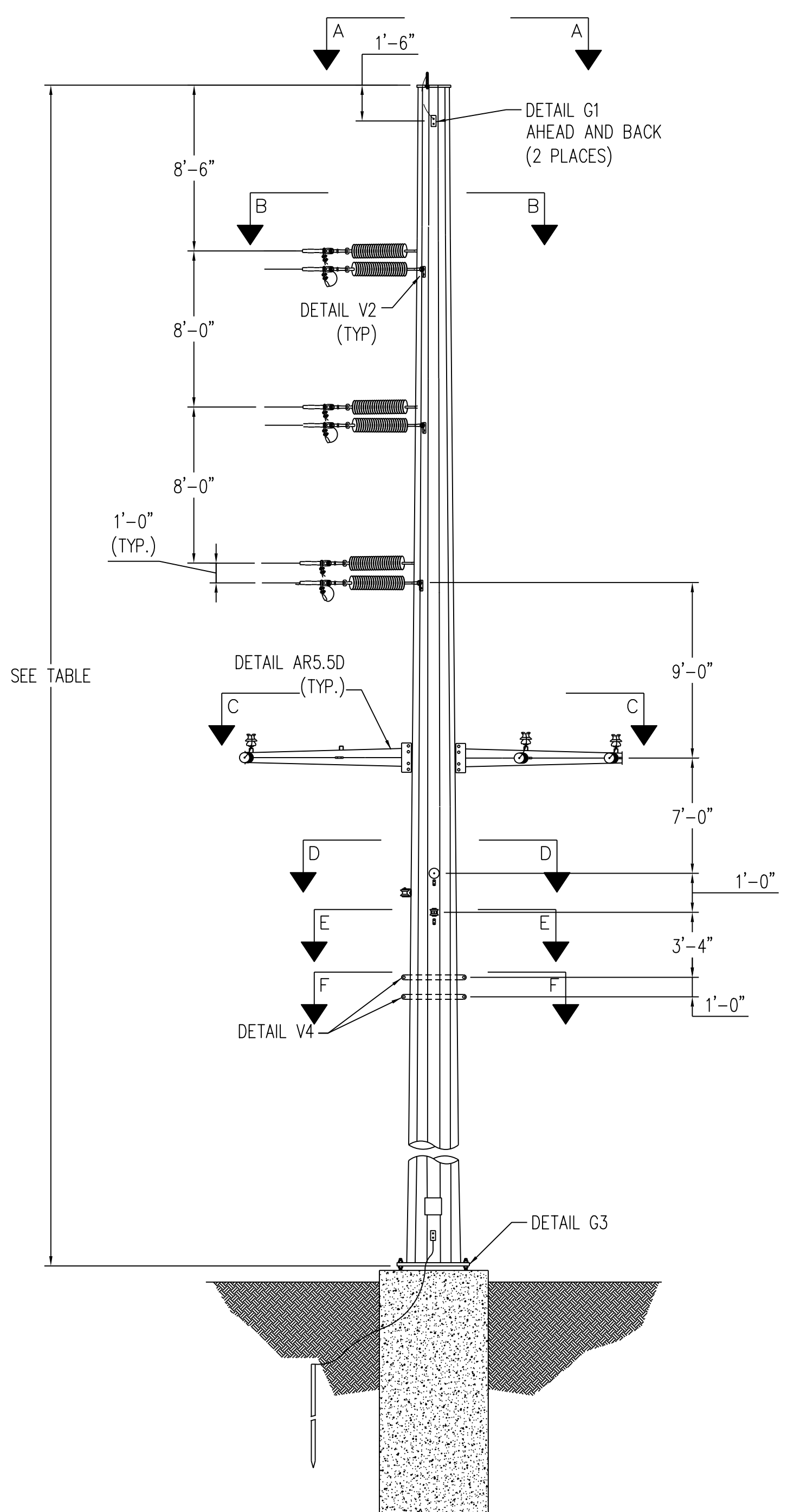

SINGLE CIRCUIT VERTICAL DEADEND
LOOKING AHEAD SPAN
SCALE: N.T.S.

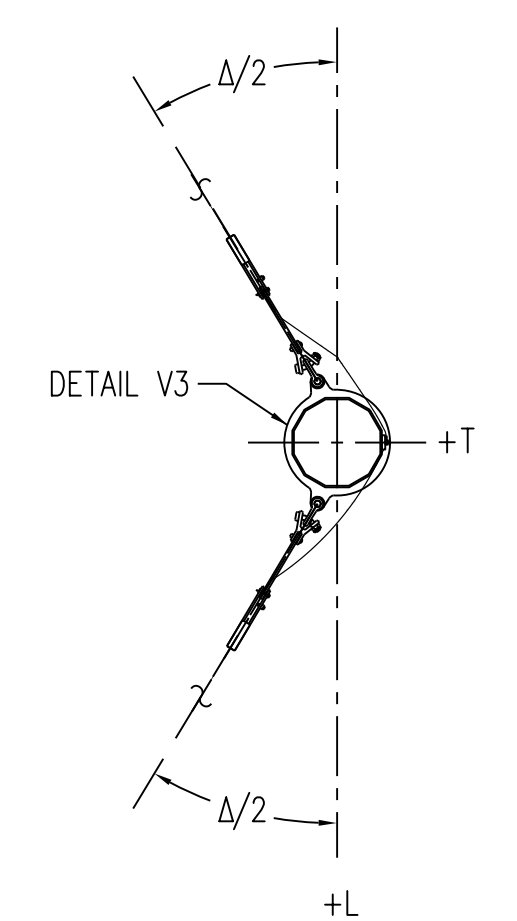

SECTION A-A (N.T.S.)
OHGW ATTACHMENT
"7/9" ALUMOWELD

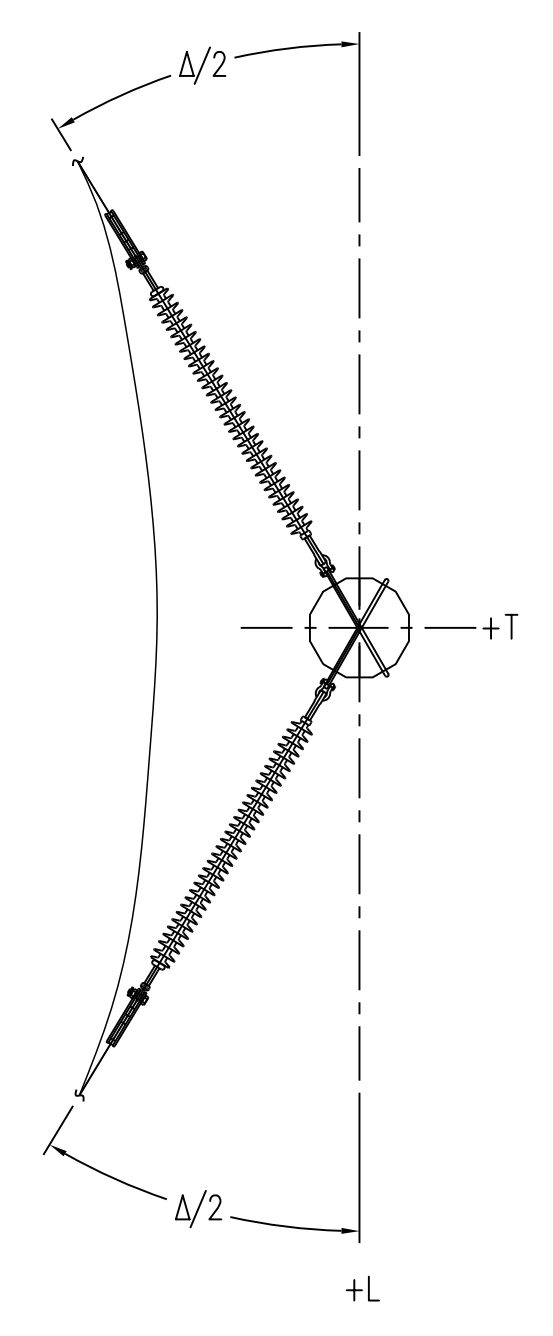

SECTION B-B (N.T.S.)
CONDUCTOR ATTACHMENT
1272 KCMIL 61/0 STRAND
"NARCISSUS" AAC

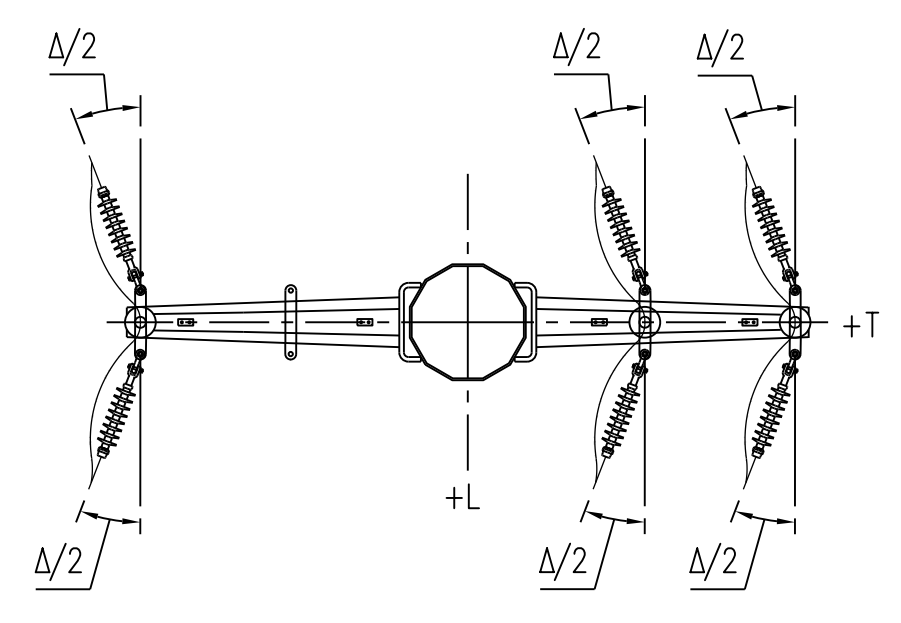

SECTION C-C (N.T.S.)
DISTRIBUTION ATTACHMENT
795 KCMIL 37/0 STRAND
"ARBUTUS" AAC

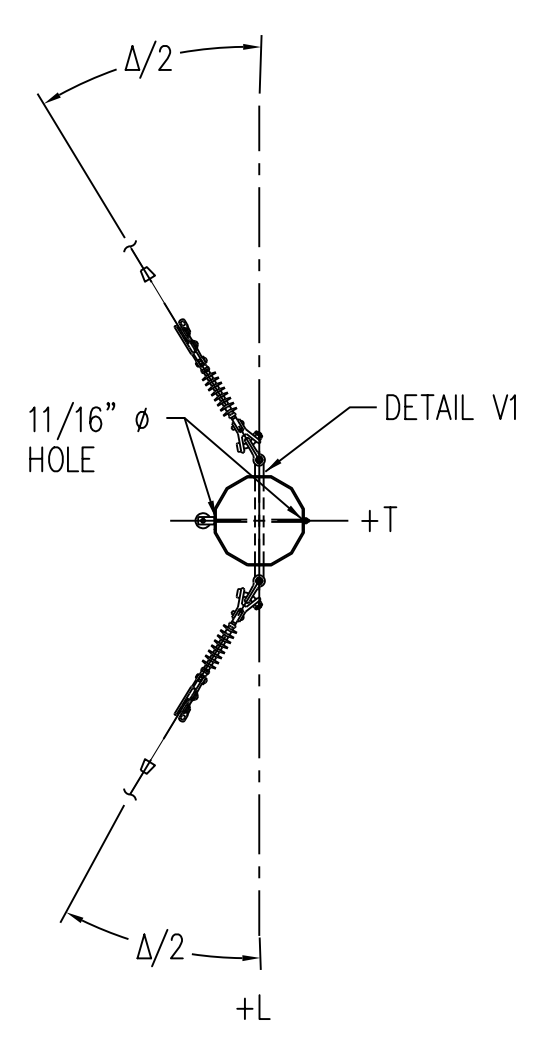

SECTION D-D (N.T.S.)
NEUTRAL ATTACHMENT
336.4 KCMIL 18/1 STRAND
"MERLIN" ACSR

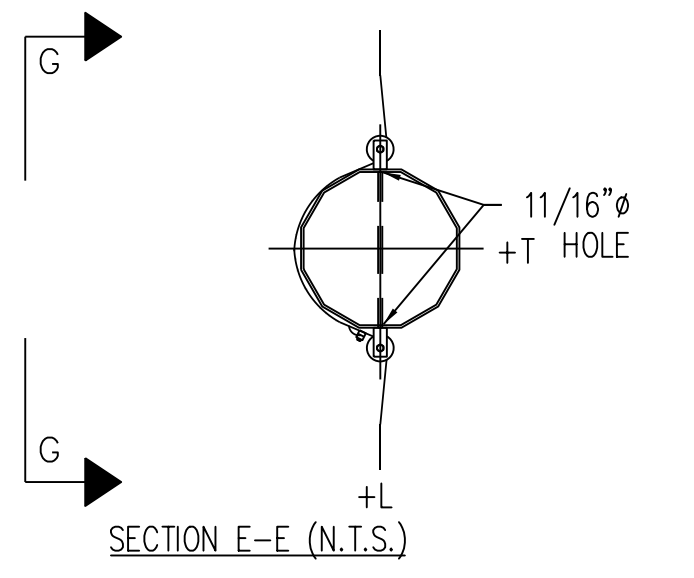

SECTION E-E (N.T.S.)
COMMUNICATIONS ATTACHMENT
"AT-XXX27DT-144-CLCB"
144 FIBER

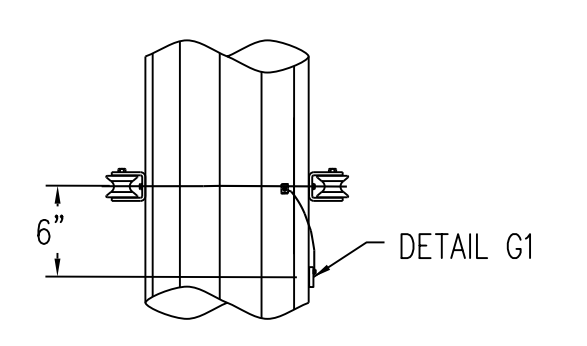

SECTION G-G (N.T.S.)
COMMUNICATIONS ATTACHMENT
"AT-XXX27DT-144-CLCB"
144 FIBER

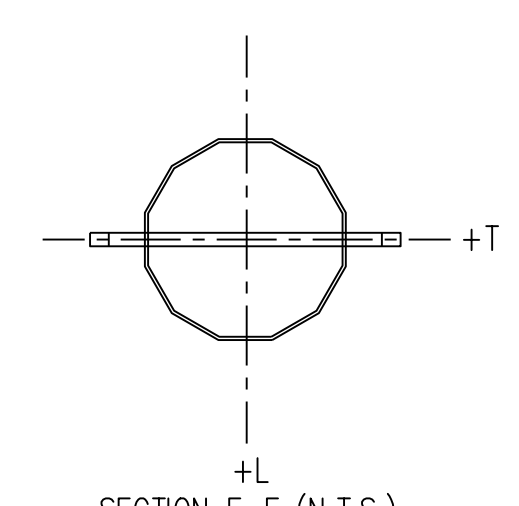

SECTION F-F (N.T.S.)
TWO WAY ONE HOLE
THROUGH VANE - VERTICAL
(N.T.S.)

STR #	LENGTH (FT)	ANGLE Δ
25	70	-94

LOADING TABLE								
LOAD	CASE 1	CASE 2	CASE 3	CASE 4	CASE 5	CASE 6	CASE 7	CASE 10
V1	100	-100	300	-100	-100	200	100	100
T1	-5200	-6500	-5100	-2600	-3300	-2700	-1000	-3700
L1	-100	-100	-200	-2100	-1500	-2300	-100	-300
V2	100	-300	400	-200	-300	300	100	600
T2	-20700	-20000	-15200	-10800	-10500	-8100	-4400	-20900
L2	-600	-700	-700	-9200	-6000	-7200	-200	-300
V3	200	-300	300	-200	-200	200	100	3700
T3	-13600	-11400	-10600	-7000	-6000	-5600	-2800	-13000
L3	-500	-500	-500	-6200	-4200	-5100	-200	-800
V4	100	-200	300	-100	-200	200	100	400
T4	-9000	-8400	-7400	-4700	-4400	-3900	-1800	-8400
L4	-400	-300	-400	-4100	-2700	-3500	-100	-200
V5	100	-100	500	-100	-100	300	100	100
T5	-2600	-2700	-2800	-1400	-1400	-1500	-1000	-1600
L5	-200	-200	-200	-1300	-1400	-1400	-100	-100
V6	300	-100	600	-200	-100	400	100	200
T6	-2400	-3400	-3400	-1300	-1800	-1700	-500	-900
L6	-100	-100	-100	-1200	-1700	-1600	-100	-100
W(PSF)	10	36.9	4.1	10	36.9	4.1	0	3

ALL LOADS ARE IN LBS, ARE ULTIMATE, AND INCLUDE ALL OVERLOAD FACTORS. "W" REPRESENTS WIND PRESSURE (psf) TO BE APPLIED TO STRUCTURE.

LOAD CASES

- CASE 1 NESM MEDIUM: 15°, .25" ICE, 4 PSF WIND
OLF: L=1.65, T=2.50, V=1.50
- CASE 2 NESM HIGH WIND: 60°, 0" ICE, 120 MPH WIND
OLF: L=1.00, T=1.00, V=1.00
- CASE 3 NESM ICE WITH WIND: 15°, 1" ICE, 40 MPH WIND
OLF: L=1.00, T=1.00, V=1.00
- CASE 4 NESM MEDIUM DEADEND: 15°, .25" ICE, 4 PSF WIND
OLF: L=1.65, T=2.50, V=1.50
- CASE 5 NESM HIGH WIND DEADEND: 60°, 0" ICE, 120 MPH WIND
OLF: L=1.00, T=1.00, V=1.00
- CASE 6 NESM ICE WITH WIND DEADEND: 15°, 1" ICE, 40 MPH WIND
OLF: L=1.00, T=1.00, V=1.00
- CASE 7 DEFLECTION: 60 DEGREES, NO ICE, NO WIND, FINAL
OLF: L=1.00, T=1.00, V=1.00
- CASE 10 STRINGING: -20°, 0" ICE, 2 PSF WIND
OLF: L=1.50, T=1.50, V=1.50

WIRE DATA

OHGW: "7#9" ALUMOWELD
115KV: 1272 KCMIL 61/0 STRAND "NARCISSUS" AAC
12.47KV: 795 KCMIL 37/0 STRAND "ARBUTUS" AAC
DISTRIBUTION NEUTRAL: 336.4 KCMIL 18/1 STRAND "MERLIN" ACSR
ADSS: "AT-XXX27DT-144-CLCB" 144 FIBER

- ALL STATED LOADS ARE ULTIMATE VALUES AND INCLUDE OVERLOAD FACTORS AND INSULATOR WEIGHT.
- STRUCTURE AND ATTACHMENTS SHALL BE DESIGNED FOR THE SIMULTANEOUS APPLICATION OF DEAD LOAD, WIND ON THE STRUCTURE, AND WIRE LOADS FOR EACH LOADING CASE.
- STRUCTURE SHALL BE DESIGNED SELF SUPPORTING, GUYS ARE NOT PERMITTED. STRUCTURE SHALL MEET ALL TECHNICAL REQUIREMENTS OF THE STEEL POLE SPECIFICATIONS.
- WIND PRESSURES SHOWN ON LOAD WORKSHEET ARE BASED ON A SHAPE FACTOR OF 1.0.
- FABRICATOR MAY PROPOSE STRUCTURAL DETAILS DIFFERENT THAN THOSE SHOWN TO SIMPLIFY FABRICATION. VARIATIONS SHALL BE SUBMITTED TO ENGINEER IN WRITING.
- MINIMUM VANG PLATE THICKNESS = 1/2".
- WIND SHALL BE APPLIED IN THE DIRECTION WHICH RESULTS IN THE MOST SEVERE EFFECT.
- THE DEFLECTION AT THE POLE TOP SHALL BE LIMITED TO 1.5% OF THE POLE HEIGHT UNDER THE DEFLECTION CASE. POLES MAY BE CAMBERED TO FALL WITHIN THE DESIGN LIMIT.
- MAXIMUM DEFLECTION AT TOP OF THE STRUCTURE SHALL BE LIMITED TO 10% OF STRUCTURE HEIGHT UNDER ALL LOAD CASES WITH THE EXCEPTION TO THE 60° NO WIND LOAD CASE.
- POLE DESIGN AND FABRICATION SHALL INCLUDE PROVISIONS FOR A SLIP JOINT TO LIMIT LOWEST POLE SEGMENT EXTENSION ABOVE GRADE TO 12'-0" MAXIMUM.
- ALL STRUCTURES SHALL BE GALVANIZED STEEL.
- ORIENT SINGLE SIDED VANGS FOR HARDWARE SHOWN ON DRAWINGS.
- MANUFACTURER SHALL APPLY POINT LOADS NECESSARY TO CREATE THE MOST SEVERE EFFECTS ON ALL MEMBERS INCLUDING ARMS, POLES, BASE PLATES, ETC.

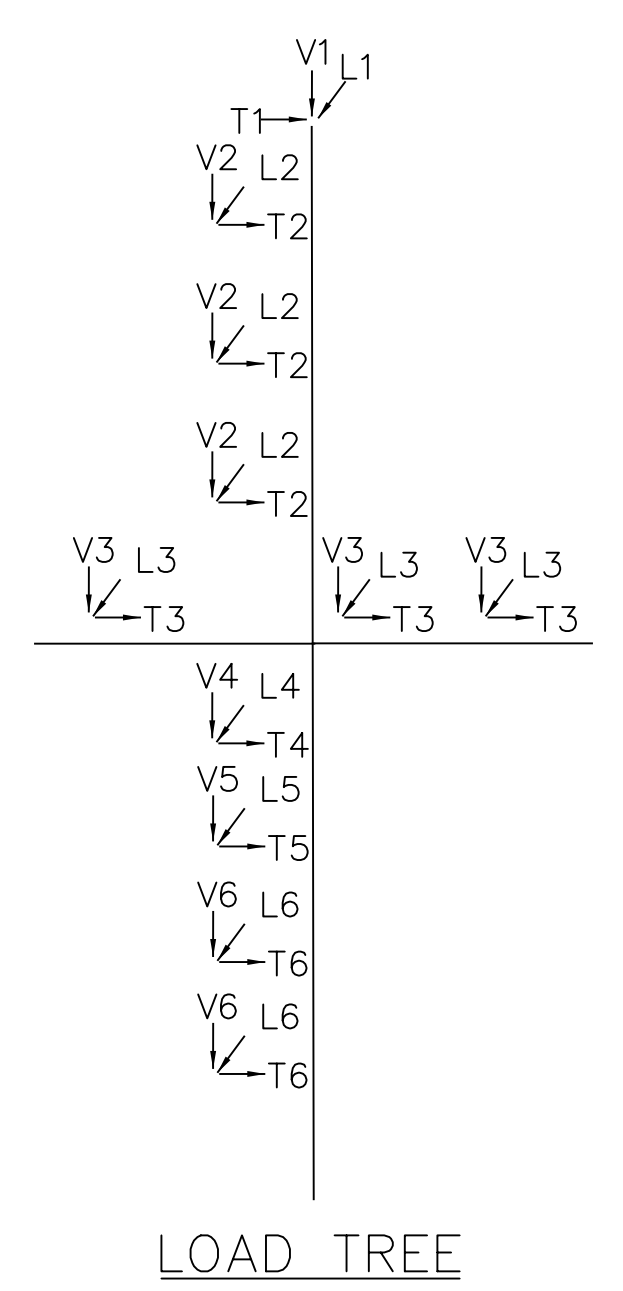

NO.	A
REVISIONS	MT. PLEASANT TO SUGG T-LINE ISSUED FOR BID ENGINEER'S S.E DATE: 12/03/21

CONSTRUCTION NOTE:
REMOVE OLD WIRE LABELS WITH ORANGE TEXT,
INSTALL NEW WIRE LABELS WITH GREEN TEXT

ISSUED FOR BID

GREENVILLE UTILITIES
Greenville, North Carolina

115KV TRANSMISSION LINE
MT. PLEASANT SUB TO SUGG
LOAD AND DESIGN
DEADEND 60'-90' WITH UNDERBUILD

DWIND. CHAMBLISS DATE 12/03/21 DWG. NO.
CKD. R. DILLABOUGH APPD. S. ECKMAN DE-90L_STR-25
SCALE: NONE

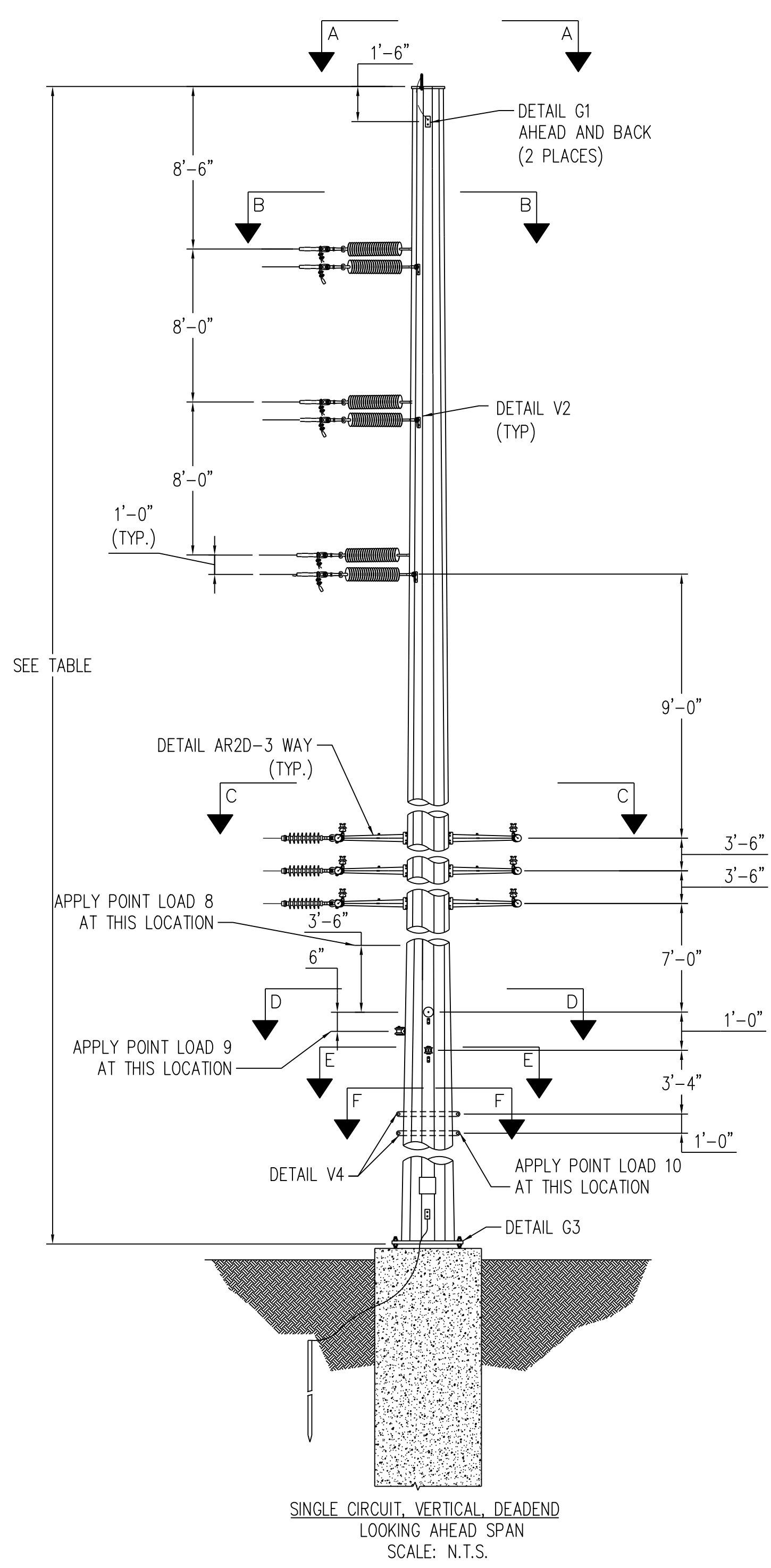

SEE TABLE

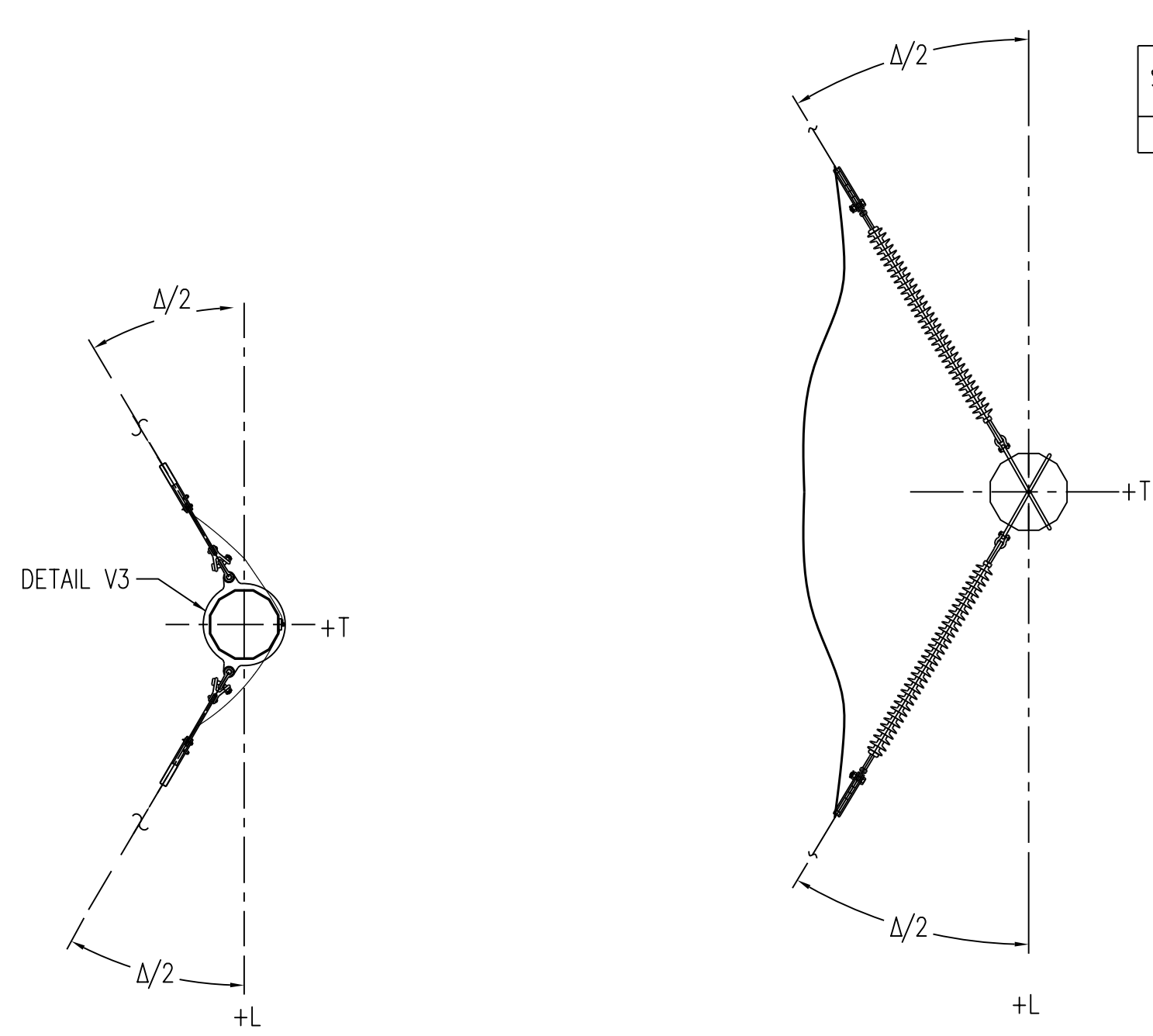

SECTION A-A (N.T.S.)

SECTION B-B (N.T.S.)

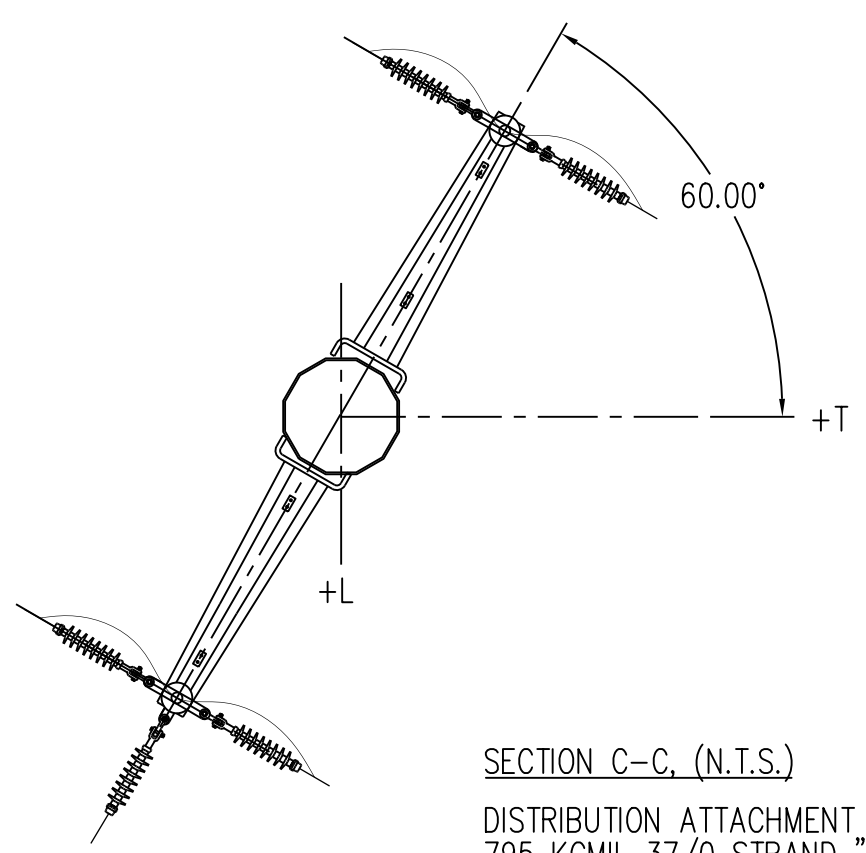

SECTION C-C (N.T.S.)

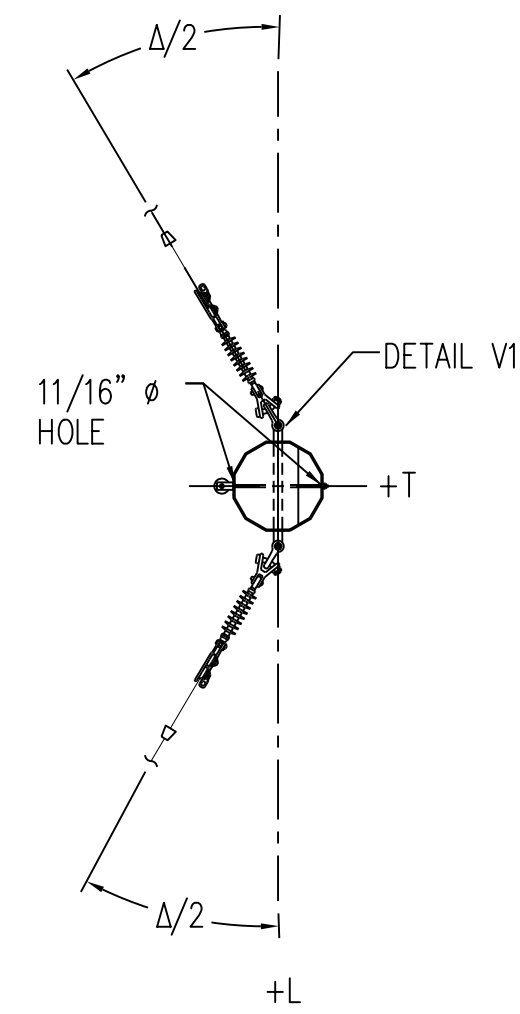

SECTION D-D (N.T.S.)

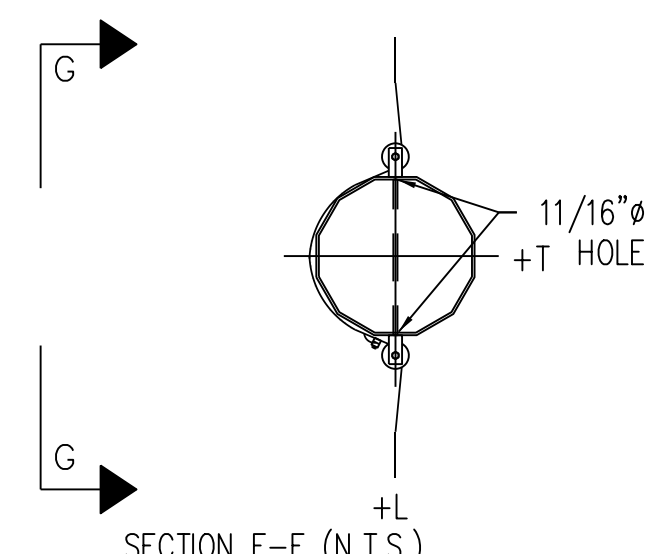

SECTION E-E (N.T.S.)

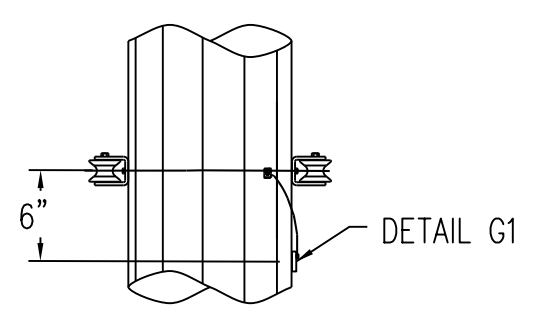

SECTION G-G (N.T.S.)

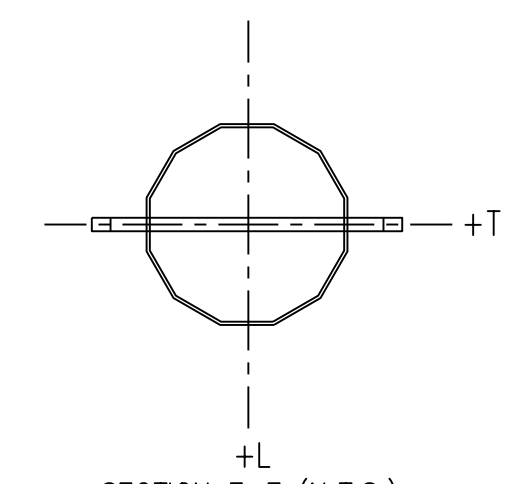

SECTION F-F (N.T.S.)

STR #	LENGTH (FT)	ANGLE Δ
52	95	-89

LOAD	LOADING TABLE										
	CASE 1	CASE 2	CASE 3	CASE 4A	CASE 5A	CASE 6A	CASE 4B	CASE 5B	CASE 6B	CASE 7	CASE 10
V1	300	200	700	300	200	700	200	-100	400	100	200
T1	-5000	-6700	-5100	-5000	-6700	-5100	-2500	-3400	-2600	-1000	-3300
L1	100	100	100	100	-100	100	-2200	-1600	-2500	100	100
V2	1000	600	1500	1000	600	1500	600	-300	800	500	900
T2	-20500	-21100	-15300	-20500	-21100	-15300	-10400	-10700	-7800	-4400	-20300
L2	100	200	100	100	-200	100	-9600	-6300	-7500	100	100
V3	400	200	700	400	200	700	-	-	-	200	300
T3	-6800	-6100	-5400	-6800	-6100	-5400	-	-	-	-1500	-6700
L3	6500	4500	5400	6500	4500	5400	-	-	-	1500	6700
V4	-500	-300	-800	-100	-100	-200	-100	-100	-200	-200	-3100
T4	-1000	-3800	-800	-4500	-4500	-3700	-4500	-4500	-3700	-200	-1000
L4	1600	1300	1600	4200	-2900	3700	-4200	-2900	-3700	400	1300
V5	-500	-300	-800	-100	-100	-200	-100	-100	-200	-200	-3100
T5	-1000	-3800	-800	-4500	-4500	-3700	-4500	-4500	-3700	400	-1000
L5	1600	1300	1600	4200	-2900	3700	-4200	-2900	-3700	400	1300
V6	200	100	700	200	100	700	100	-100	400	100	100
T6	-2700	-2800	-2900	-2700	-2800	-2900	-1400	-1500	-900	-1500	-1500
L6	100	100	100	100	-100	100	-1400	-1500	-1500	100	100
V7	400	100	900	400	100	900	200	-100	500	200	200
T7	-2400	-3500	-3300	-2400	-3500	-3300	-1300	-1800	-1700	-500	-900
L7	100	100	100	100	-100	100	-1300	-1800	-1700	100	100
V8	500	200	1500	-	-	-	-	-	-	200	200
T8	1300	600	1100	-	-	-	-	-	-	400	1500
L8	-1800	-1100	-1600	-	-	-	-	-	-	-500	-1900
V9	2100	800	5100	-	-	-	-	-	-	800	1300
T9	4700	2000	3800	-	-	-	-	-	-	1200	5800
L9	900	500	600	-	-	-	-	-	-	100	1400
V10	1400	500	3200	-	-	-	-	-	-	500	800
T10	1200	600	1300	-	-	-	-	-	-	500	1000
L10	300	300	300	-	-	-	-	-	-	100	300
W(PSF)	10	36.9	4.1	10	36.9	4.1	10	36.9	4.1	0	3

ALL LOADS ARE IN LBS, ARE ULTIMATE, AND INCLUDE ALL OVERLOAD FACTORS. "W" REPRESENTS WIND PRESSURE (psf) TO BE APPLIED TO STRUCTURE.

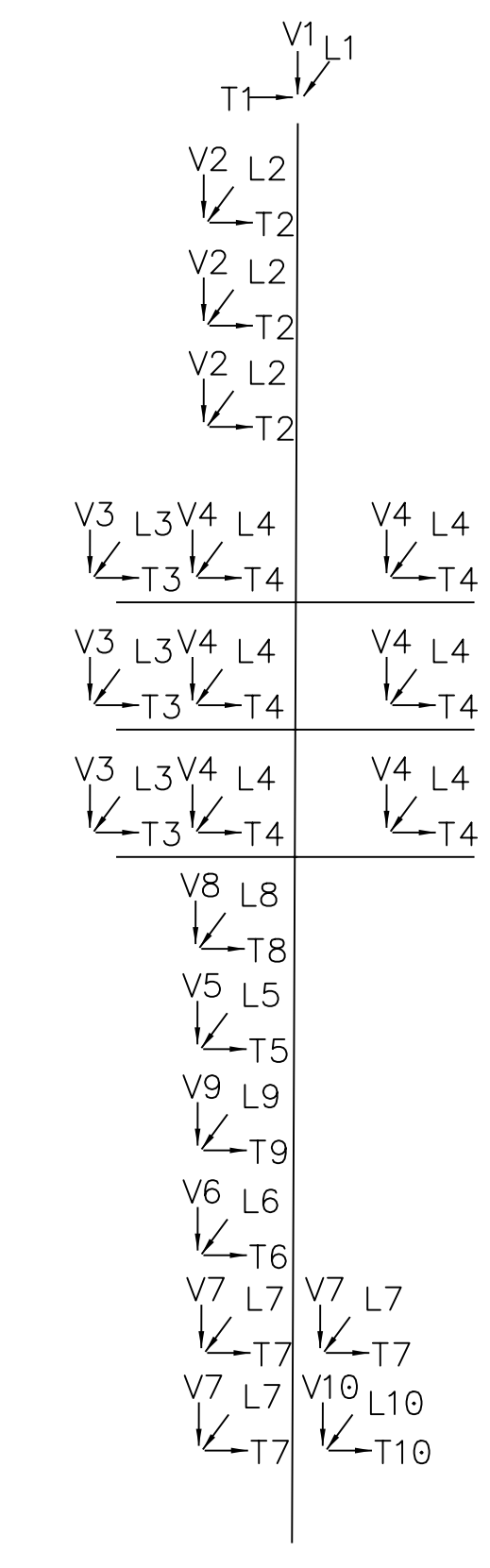

LOAD TREE

LOAD CASES

- CASE 1 NESC MEDIUM: 15°, .25" ICE, 4 PSF WIND OLF: L=1.65, T=2.50, V=1.50
- CASE 2 NESC HIGH WIND: 60°, 0" ICE, 120 MPH WIND OLF: L=1.00, T=1.00, V=1.00
- CASE 3 NESC ICE WITH WIND: 15°, 1" ICE, 40 MPH WIND OLF: L=1.00, T=1.00, V=1.00
- CASE 4 NESC MEDIUM DEADEND: 15°, .25" ICE, 4 PSF WIND, OLF: L=1.65, T=2.50, V=1.50
- CASE 4A NESC MEDIUM MAIN ALIGNMENT DEADEND: 15°, .25" ICE, 4 PSF WIND, OLF: L=1.65, T=2.50, V=1.50
- CASE 4B NESC MEDIUM ONE-WAY DEADEND: 15°, .25" ICE, 4 PSF WIND, OLF: L=1.65, T=2.50, V=1.50
- CASE 5 NESC HIGH WIND DEADEND: 60°, 0" ICE, 120 MPH WIND OLF: L=1.00, T=1.00, V=1.00
- CASE 5A NESC HIGH WIND MAIN ALIGNMENT DEADEND: 60°, 0" ICE, 120 MPH WIND, OLF: L=1.00, T=1.00, V=1.00
- CASE 5B NESC HIGH WIND ONE-WAY DEADEND: 60°, 0" ICE, 120 MPH WIND, OLF: L=1.00, T=1.00, V=1.00
- CASE 6 NESC ICE WITH WIND DEADEND: 15°, 1" ICE, 40 MPH WIND OLF: L=1.00, T=1.00, V=1.00
- CASE 6A NESC ICE WITH WIND MAIN ALIGNMENT DEADEND: 15°, 1" ICE, 40 MPH WIND, OLF: L=1.00, T=1.00, V=1.00
- CASE 6B NESC ICE WITH WIND ONE-WAY DEADEND: 15°, 1" ICE, 40 MPH WIND, OLF: L=1.00, T=1.00, V=1.00
- CASE 7 DEFLECTION: 60 DEGREES, NO ICE, NO WIND, FINAL OLF: L=1.00, T=1.00, V=1.00
- CASE 10 STRINGING: -20°, 0" ICE, 2 PSF WIND OLF: L=1.50, T=1.50, V=1.50

WIRE DATA

OHGW: "7#9" ALUMOWELD
 115KV: 1272 KCMIL 61/0 STRAND "NARCISSUS" AAC
 12.47KV: 795 KCMIL 37/0 STRAND "ARBUTUS" AAC
 DISTRIBUTION NEUTRAL: 336.4 KCMIL 18/1 STRAND "MERLIN" ACSR
 ADSS: "AT-XXX27DT-144-CLCB" 144 FIBER

NOTES:

- ALL STATED LOADS ARE ULTIMATE VALUES AND INCLUDE OVERLOAD FACTORS AND INSULATOR WEIGHT.
- STRUCTURE AND ATTACHMENTS SHALL BE DESIGNED FOR THE SIMULTANEOUS APPLICATION OF DEAD LOAD, WIND ON THE STRUCTURE, AND WIRE LOADS FOR EACH LOADING CASE.
- STRUCTURE SHALL BE DESIGNED SELF SUPPORTING, GUYS ARE NOT PERMITTED. STRUCTURE SHALL MEET ALL TECHNICAL REQUIREMENTS OF THE STEEL POLE SPECIFICATIONS.
- WIND PRESSURES SHOWN ON LOAD WORKSHEET ARE BASED ON A SHAPE FACTOR OF 1.0.
- FABRICATOR MAY PROPOSE STRUCTURAL DETAILS DIFFERENT THAN THOSE SHOWN TO SIMPLIFY FABRICATION. VARIATIONS SHALL BE SUBMITTED TO ENGINEER IN WRITING.
- MINIMUM VANG PLATE THICKNESS = 1/2".
- WIND SHALL BE APPLIED IN THE DIRECTION WHICH RESULTS IN THE MOST SEVERE EFFECT.
- THE DEFLECTION AT THE POLE TOP SHALL BE LIMITED TO 1.5% OF THE POLE HEIGHT UNDER THE DEFLECTION CASE. POLES MAY BE CAMBERED TO FALL WITHIN THE DESIGN LIMIT.
- MAXIMUM DEFLECTION AT TOP OF THE STRUCTURE SHALL BE LIMITED TO 10% OF STRUCTURE HEIGHT UNDER ALL LOAD CASES WITH THE EXCEPTION TO THE 60°F NO WIND LOAD CASE.
- POLE DESIGN AND FABRICATION SHALL INCLUDE PROVISIONS FOR A SLIP JOINT TO LIMIT LOWEST POLE SEGMENT EXTENSION ABOVE GRADE TO 12'-0" MAXIMUM.
- ALL STRUCTURES SHALL BE GALVANIZED STEEL.
- ORIENT SINGLE SIDED VANGS FOR HARDWARE SHOWN ON DRAWINGS.
- MANUFACTURER SHALL APPLY POINT LOADS NECESSARY TO CREATE THE MOST SEVERE EFFECTS ON ALL MEMBERS INCLUDING ARMS, POLES, BASE PLATES, ETC.

NO.	A
REVISIONS	MT. PLEASANT TO SUGG T-LINE ISSUED FOR BID ENGINEER'S S.E DATE: 12/03/21

CONSTRUCTION NOTE:
 REMOVE OLD WIRE LABELS WITH ORANGE TEXT,
 INSTALL NEW WIRE LABELS WITH GREEN TEXT

ISSUED FOR BID

GREENVILLE UTILITIES
 Greenville, North Carolina

115KV TRANSMISSION LINE
 MT. PLEASANT SUB TO SUGG
 LOAD AND DESIGN
 DEADEND 60°-90° WITH UNDERBUILD

DWN.D. CHAMBLISS DATE 12/03/21
 CKD. R. DILLABOUGH APPD. S. ECKMAN
 SCALE: NONE

DWG. NO.
 DE-90L_STR-52

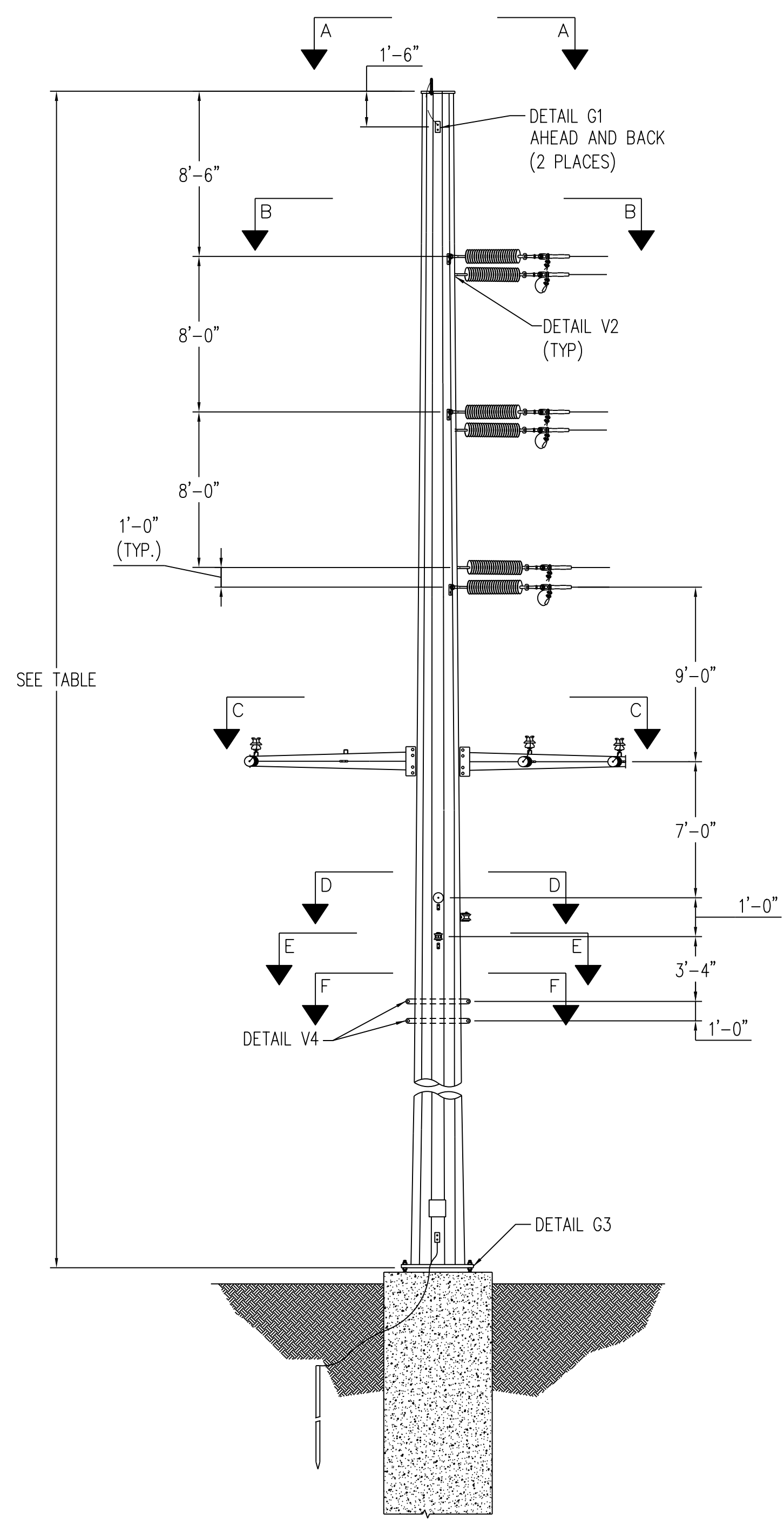

SINGLE CIRCUIT, VERTICAL, DEADEND
LOOKING AHEAD SPAN
SCALE: N.T.S.

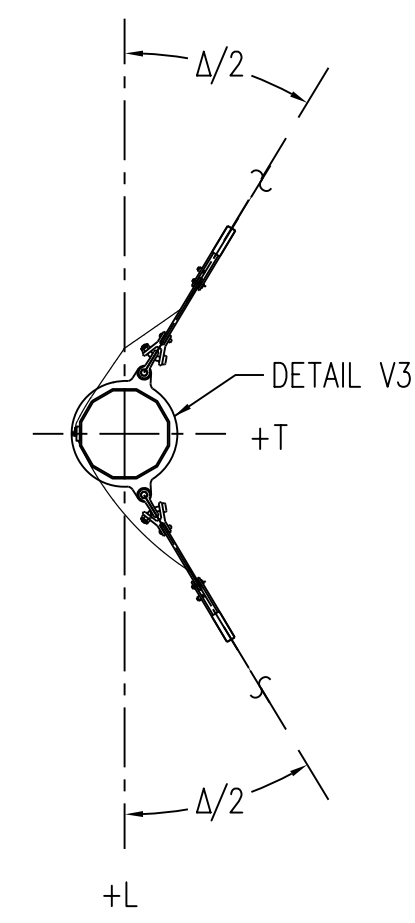

SECTION A-A (N.T.S.)
OHGW ATTACHMENT
7/9" ALUMOWELD

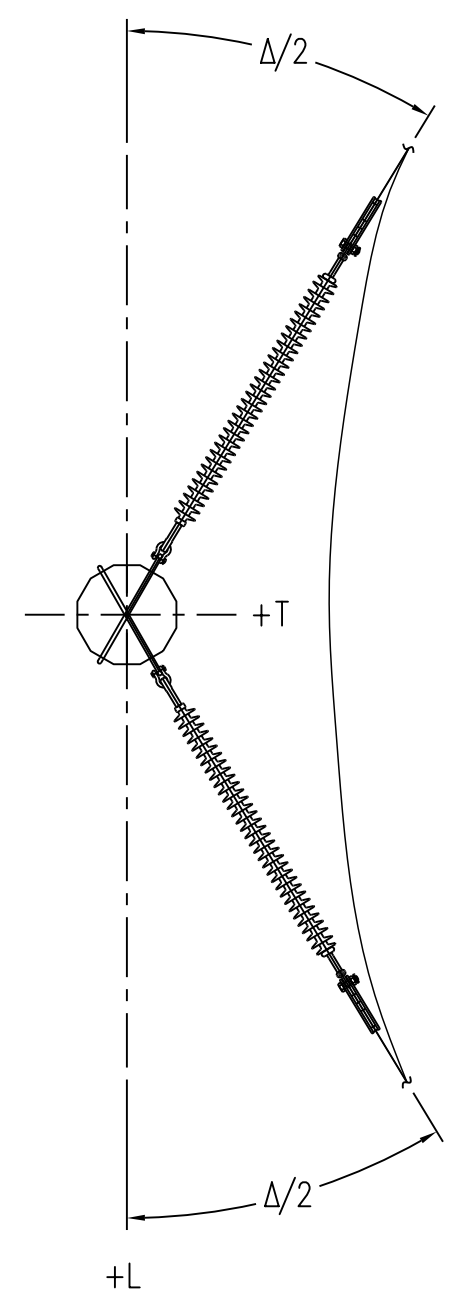

SECTION B-B (N.T.S.)
CONDUCTOR ATTACHMENT
1272 KCMIL 61/0 STRAND
"NARCISSUS" AAC

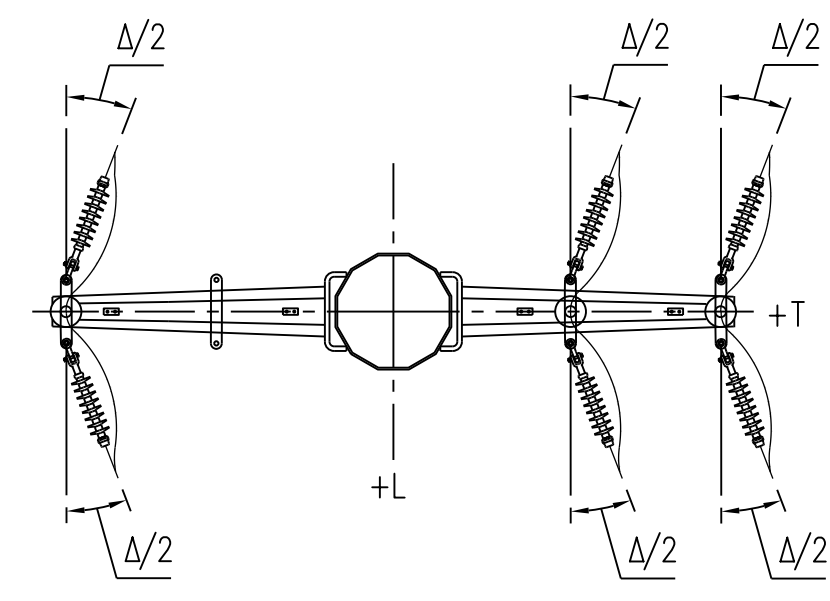

SECTION C-C (N.T.S.)
DISTRIBUTION ATTACHMENT
795 KCMIL 37/0 STRAND
"ARBUTUS" AAC

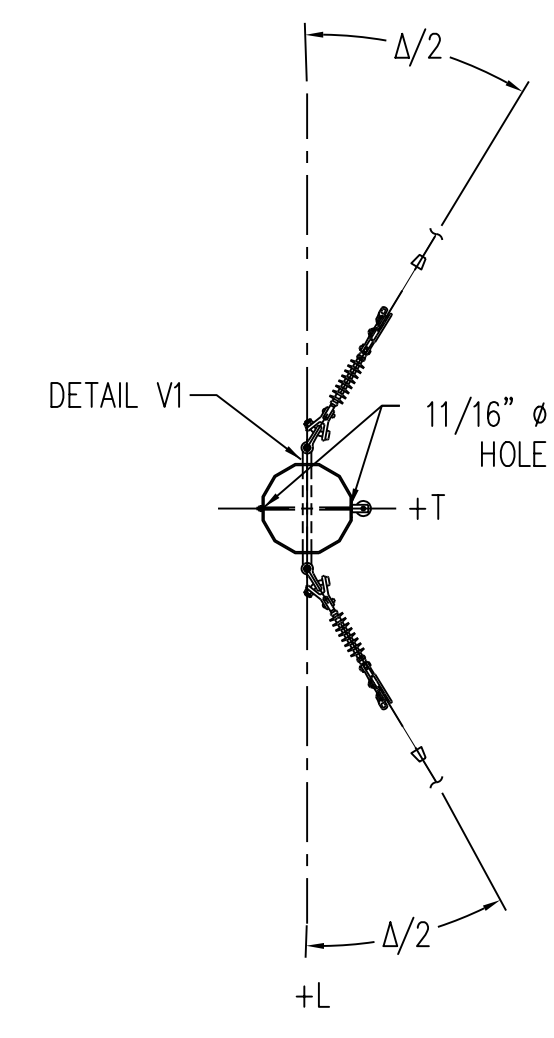

SECTION D-D (N.T.S.)
NEUTRAL ATTACHMENT
336.4 KCMIL 18/1 STRAND
"MERLIN" ACSR

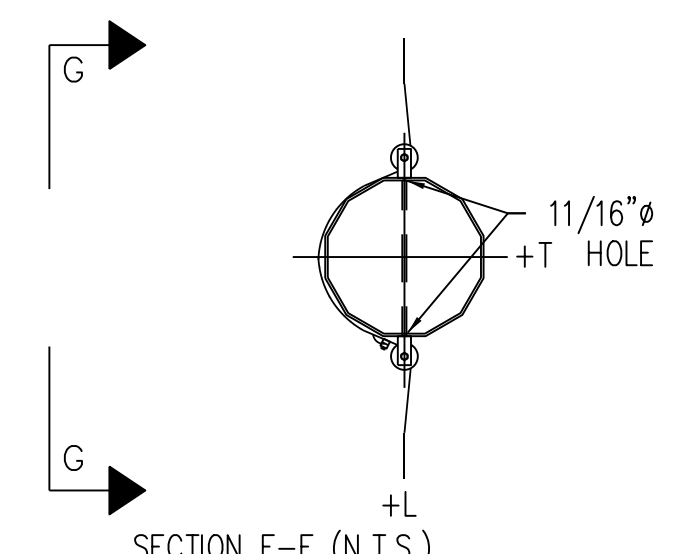

SECTION E-E (N.T.S.)
COMMUNICATIONS ATTACHMENT
"AT-XXX27DT-144-CLCB"
144 FIBER

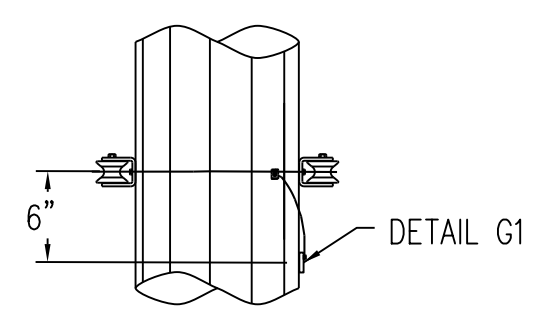

SECTION G-G (N.T.S.)
COMMUNICATIONS ATTACHMENT
"AT-XXX27DT-144-CLCB"
144 FIBER

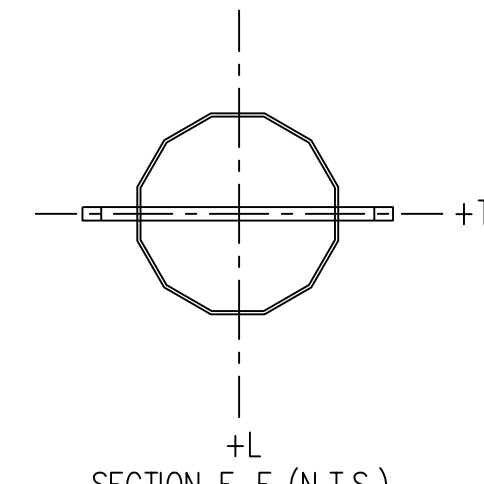

SECTION F-F (N.T.S.)
TWO WAY ONE HOLE
THROUGH VANE - VERTICAL
(N.T.S.)

STR #	LENGTH (FT)	ANGLE Δ
23	95	89

LOAD	LOADING TABLE									
	CASE 1	CASE 2	CASE 3	CASE 4	CASE 5	CASE 6	CASE 7	CASE 10		
V1	300	200	600	300	200	500	100	200		
T1	6300	7100	5200	3800	3900	2900	1800	5300		
L1	1400	700	-600	-3500	-2100	-2700	700	1600		
V2	1100	600	1300	1000	600	1100	500	1100		
T2	19300	19500	13900	9900	9900	7200	4000	20000		
L2	100	200	-200	-8700	-5400	-6600	100	200		
V3	700	400	1000	600	400	800	300	4700		
T3	12400	10800	9600	6300	5500	4900	2500	12200		
L3	200	200	-300	-6100	-3900	-4800	100	900		
V4	600	400	900	400	300	600	200	600		
T4	8300	8100	6600	4200	4200	3400	1600	7900		
L4	200	100	-200	-3900	-2500	-3300	100	100		
V5	300	200	700	200	200	400	100	200		
T5	2400	2400	2500	1200	1300	1300	900	1500		
L5	100	100	-100	-1300	-1300	-1300	100	100		
V6	400	300	900	300	200	500	200	200		
T6	2400	3300	3100	1200	1700	1600	500	900		
L6	100	100	-100	-1200	-1700	-1600	100	100		
W(PSF)	10	36.9	4.1	10	36.9	4.1	0	3		

ALL LOADS ARE IN LBS, ARE ULTIMATE, AND INCLUDE ALL OVERLOAD FACTORS. "W" REPRESENTS WIND PRESSURE (psf) TO BE APPLIED TO STRUCTURE.

LOAD CASES

- CASE 1 NESM MEDIUM: 15°, .25" ICE, 4 PSF WIND
OLF: L=1.65, T=2.50, V=1.50
- CASE 2 NESM HIGH WIND: 60°, 0" ICE, 120 MPH WIND
OLF: L=1.00, T=1.00, V=1.00
- CASE 3 NESM ICE WITH WIND: 15°, 1" ICE, 40 MPH WIND
OLF: L=1.00, T=1.00, V=1.00
- CASE 4 NESM MEDIUM DEADEND: 15°, .25" ICE, 4 PSF WIND
OLF: L=1.65, T=2.50, V=1.50
- CASE 5 NESM HIGH WIND DEADEND: 60°, 0" ICE, 120 MPH WIND
OLF: L=1.00, T=1.00, V=1.00
- CASE 6 NESM ICE WITH WIND DEADEND: 15°, 1" ICE, 40 MPH WIND
OLF: L=1.00, T=1.00, V=1.00
- CASE 7 DEFLECTION: 60 DEGREES, NO ICE, NO WIND, FINAL
OLF: L=1.00, T=1.00, V=1.00
- CASE 10 STRINGING: -20°, 0" ICE, 2 PSF WIND
OLF: L=1.50, T=1.50, V=1.50

WIRE DATA

OHGW: "7#9" ALUMOWELD
115KV: 1272 KCMIL 61/0 STRAND "NARCISSUS" AAC
12.47KV: 795 KCMIL 37/0 STRAND "ARBUTUS" AAC
DISTRIBUTION NEUTRAL: 336.4 KCMIL 18/1 STRAND "MERLIN" ACSR
ADSS: "AT-XXX27DT-144-CLCB" 144 FIBER

NOTES:

- ALL STATED LOADS ARE ULTIMATE VALUES AND INCLUDE OVERLOAD FACTORS AND INSULATOR WEIGHT.
- STRUCTURE AND ATTACHMENTS SHALL BE DESIGNED FOR THE SIMULTANEOUS APPLICATION OF DEAD LOAD, WIND ON THE STRUCTURE, AND WIRE LOADS FOR EACH LOADING CASE.
- STRUCTURE SHALL BE DESIGNED SELF SUPPORTING, GUYS ARE NOT PERMITTED. STRUCTURE SHALL MEET ALL TECHNICAL REQUIREMENTS OF THE STEEL POLE SPECIFICATIONS.
- WIND PRESSURES SHOWN ON LOAD WORKSHEET ARE BASED ON A SHAPE FACTOR OF 1.0.
- FABRICATOR MAY PROPOSE STRUCTURAL DETAILS DIFFERENT THAN THOSE SHOWN TO SIMPLIFY FABRICATION. VARIATIONS SHALL BE SUBMITTED TO ENGINEER IN WRITING.
- MINIMUM VANG PLATE THICKNESS = 1/2".
- WIND SHALL BE APPLIED IN THE DIRECTION WHICH RESULTS IN THE MOST SEVERE EFFECT.
- THE DEFLECTION AT THE POLE TOP SHALL BE LIMITED TO 1.5% OF THE POLE HEIGHT UNDER THE DEFLECTION CASE. POLES MAY BE CAMBERED TO FALL WITHIN THE DESIGN LIMIT.
- MAXIMUM DEFLECTION AT TOP OF THE STRUCTURE SHALL BE LIMITED TO 10% OF STRUCTURE HEIGHT UNDER ALL LOAD CASES WITH THE EXCEPTION TO THE 60° NO WIND LOAD CASE.
- POLE DESIGN AND FABRICATION SHALL INCLUDE PROVISIONS FOR A SLIP JOINT TO LIMIT LOWEST POLE SEGMENT EXTENSION ABOVE GRADE TO 12'-0" MAXIMUM.
- ALL STRUCTURES SHALL BE GALVANIZED STEEL.
- ORIENT SINGLE SIDED VANGS FOR HARDWARE SHOWN ON DRAWINGS.
- MANUFACTURER SHALL APPLY POINT LOADS NECESSARY TO CREATE THE MOST SEVERE EFFECTS ON ALL MEMBERS INCLUDING ARMS, POLES, BASE PLATES, ETC.

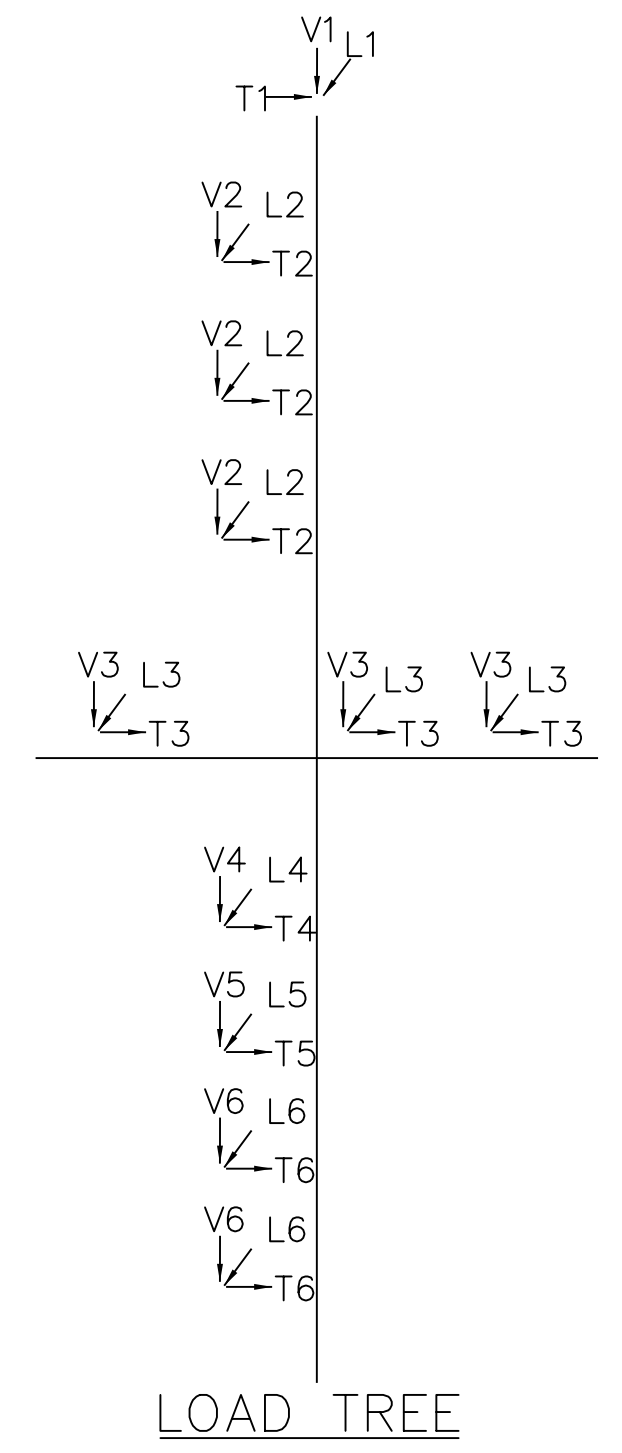

NO.	A
REVISIONS	MT. PLEASANT TO SUGG T-LINE ISSUED FOR BID ENGINEERS: S.E DATE: 12/03/21

CONSTRUCTION NOTE:
REMOVE OLD WIRE LABELS WITH ORANGE TEXT,
INSTALL NEW WIRE LABELS WITH GREEN TEXT

ISSUED FOR BID

GREENVILLE UTILITIES
Greenville, North Carolina

115KV TRANSMISSION LINE
MT. PLEASANT SUB TO SUGG
LOAD AND DESIGN
DEADEND 60°-90° WITH UNDERBUILD

DWIND. CHAMBLISS DATE 12/03/21 DWG. NO.
CKD. R. DILLABOUGH APPD. S. ECKMAN DE-90R_STR-23
SCALE: NONE

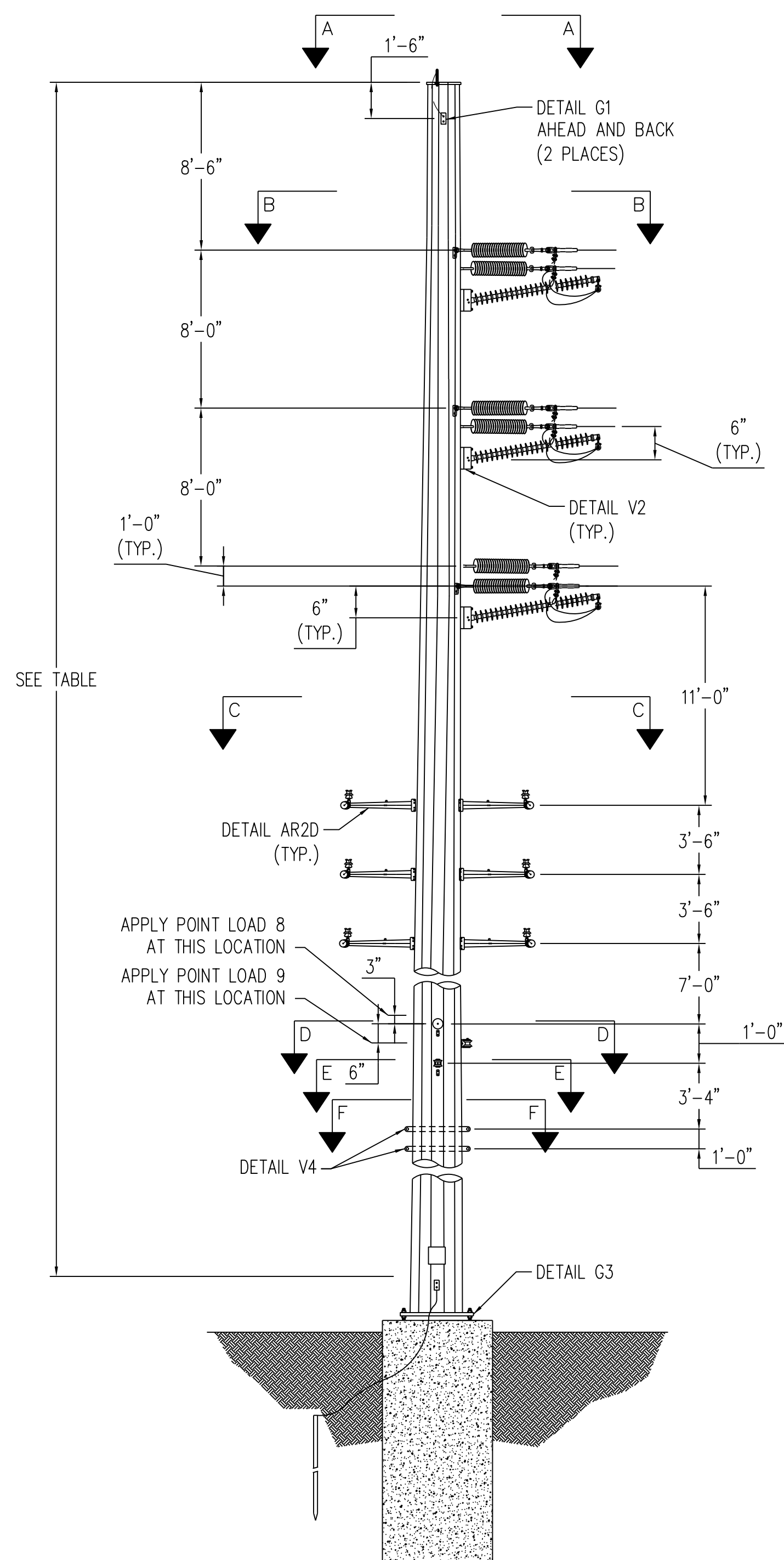

SEE TABLE

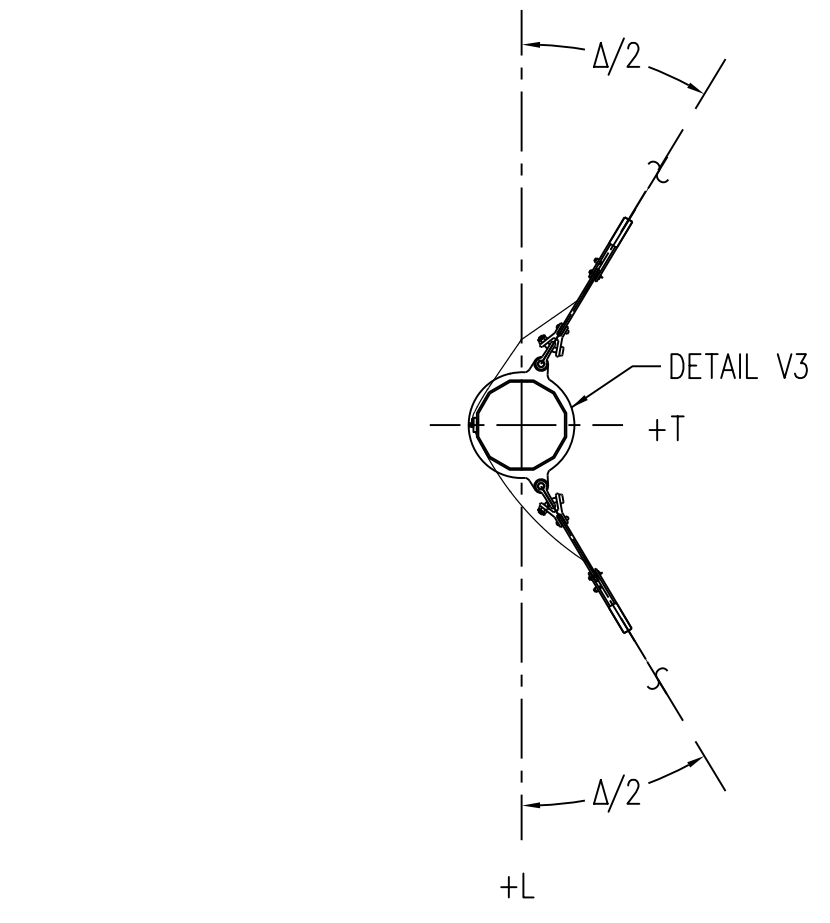

SECTION A-A (N.T.S.)
OHGW ATTACHMENT
7/9" ALUMOWELD

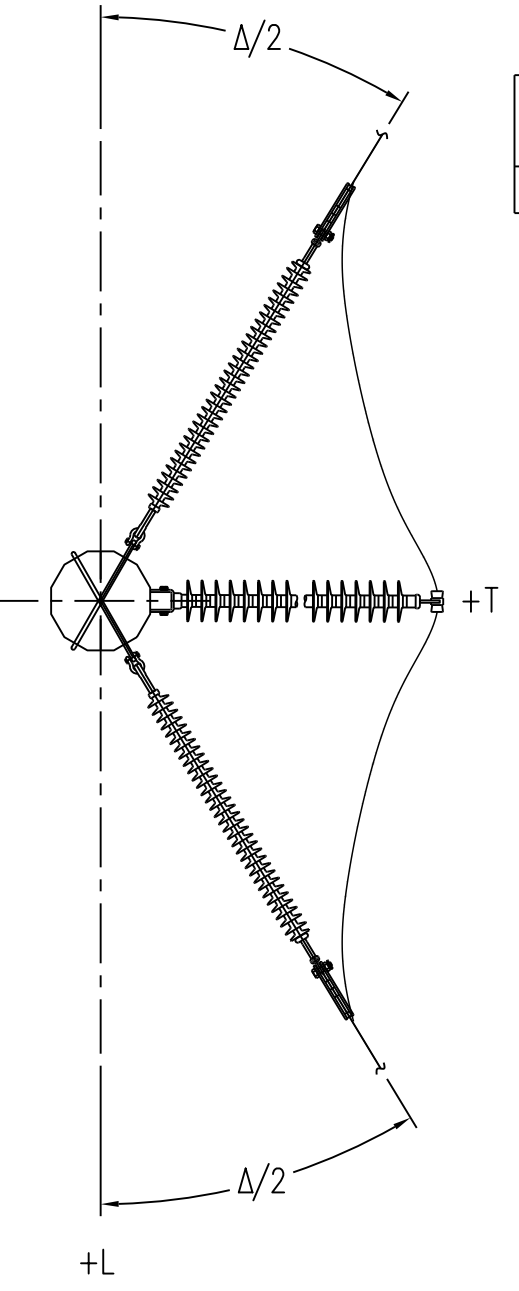

SECTION B-B (N.T.S.)
CONDUCTOR ATTACHMENT
1272 KCMIL 61/0 STRAND
'NARCISSUS' AAC

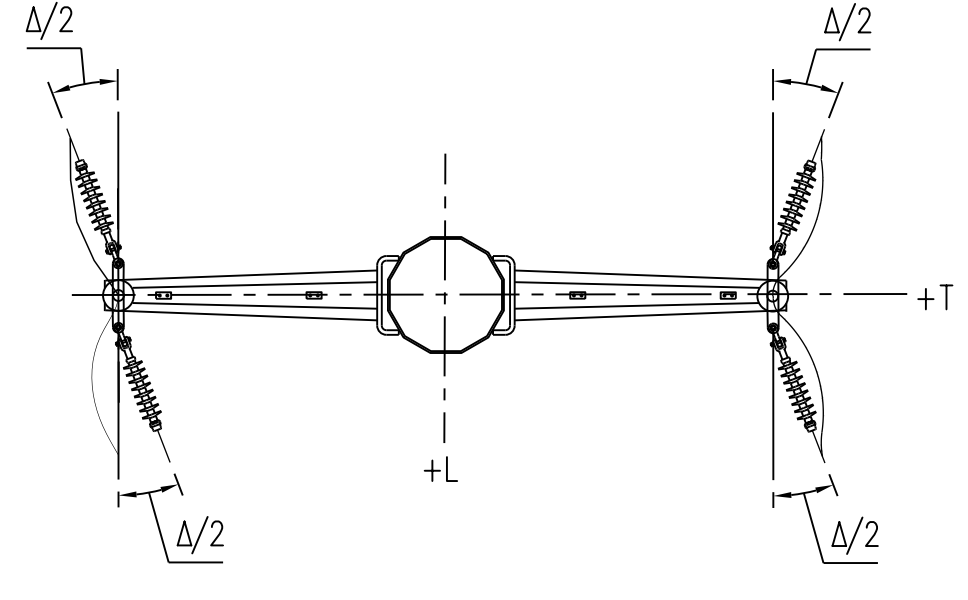

SECTION C-C (N.T.S.)
DISTRIBUTION ATTACHMENT
336.4 KCMIL 18/1 STRAND
'MERLIN' ACSR

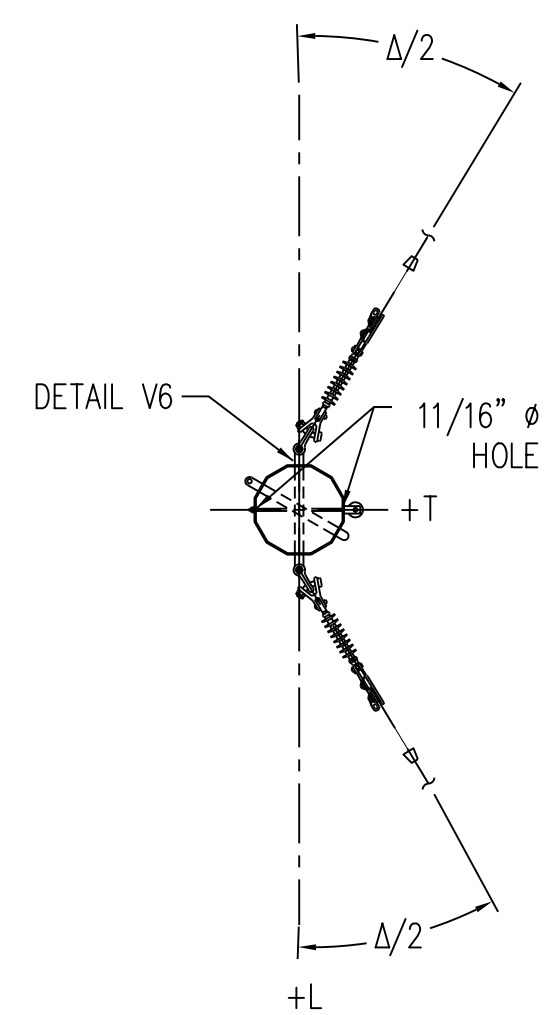

SECTION D-D (N.T.S.)
NEUTRAL ATTACHMENT
336.4 KCMIL 18/1 STRAND
'MERLIN' ACSR

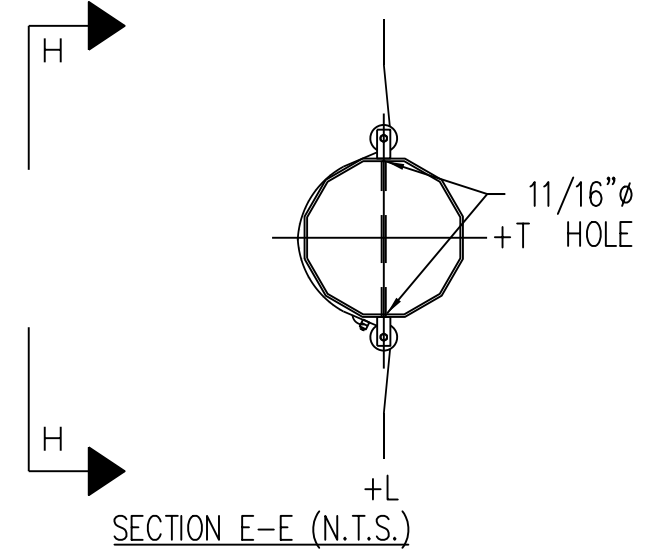

SECTION E-E (N.T.S.)
COMMUNICATIONS ATTACHMENT
'AT-XXX27DT-144-CLCB'
144 FIBER

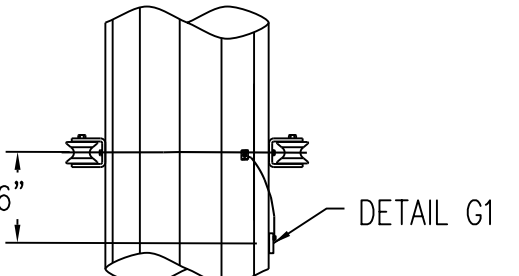

SECTION H-H (N.T.S.)
COMMUNICATIONS ATTACHMENT
'AT-XXX27DT-144-CLCB'
144 FIBER

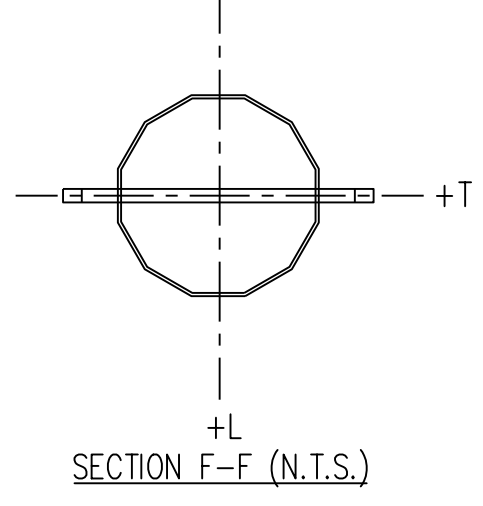

SECTION F-F (N.T.S.)
TWO WAY ONE HOLE
THROUGH VANG - VERTICAL
(N.T.S.)

STR #	LENGTH (FT)	ANGLE Δ
62	105	73

LOADING TABLE									
LOAD	CASE 1	CASE 2	CASE 3	CASE 4	CASE 5	CASE 6	CASE 7	CASE 10	
V1	400	200	900	200	200	500	200	300	
T1	5600	7100	5300	3400	3900	3100	1300	4000	
L1	-1600	-1000	-1200	4000	2600	3900	-700	1600	
V2	1500	800	2000	900	600	1200	700	1300	
T2	18500	20900	14000	9800	11000	7600	4200	17400	
L2	-1000	-1400	-1300	11600	8400	9600	-500	300	
V3	1100	800	1500	700	500	900	400	3800	
T3	1600	4400	1200	4000	4300	3300	300	1100	
L3	-1100	-1200	-1100	4700	3300	4100	-300	1200	
V4	600	300	1100	400	300	700	200	3000	
T4	8000	8800	6900	4100	4600	3700	1600	6500	
L4	-200	-500	-600	4900	3800	4600	-100	800	
V5	600	300	1100	400	300	700	200	3000	
T5	8000	8800	6900	4100	4600	3700	1600	6500	
L5	-200	-500	-600	4900	3800	4600	-100	800	
V6	400	200	1000	200	200	600	200	200	
T6	2400	2700	2700	1200	1500	1400	600	1100	
L6	-200	-200	-200	1500	1700	1800	-300	400	
V7	600	300	1300	300	200	700	200	300	
T7	2200	3400	3000	1200	1800	1600	400	800	
L7	-100	-200	-100	1400	2100	2000	-100	100	
V8	1000	300	3600	-	-	-	300	1600	
T8	-1200	-500	-1000	-	-	-	-400	-1300	
L8	-1800	-1100	-1600	-	-	-	-500	-1700	
V9	400	100	1500	-	-	-	100	200	
T9	300	400	200	-	-	-	-100	200	
L9	-300	-300	-400	-	-	-	-100	-100	
W(PSF)	10	36.9	4.1	10	36.9	4.1	0	3	

ALL LOADS ARE IN LBS, ARE ULTIMATE, AND INCLUDE ALL OVERLOAD FACTORS. "W" REPRESENTS WIND PRESSURE (psf) TO BE APPLIED TO STRUCTURE.

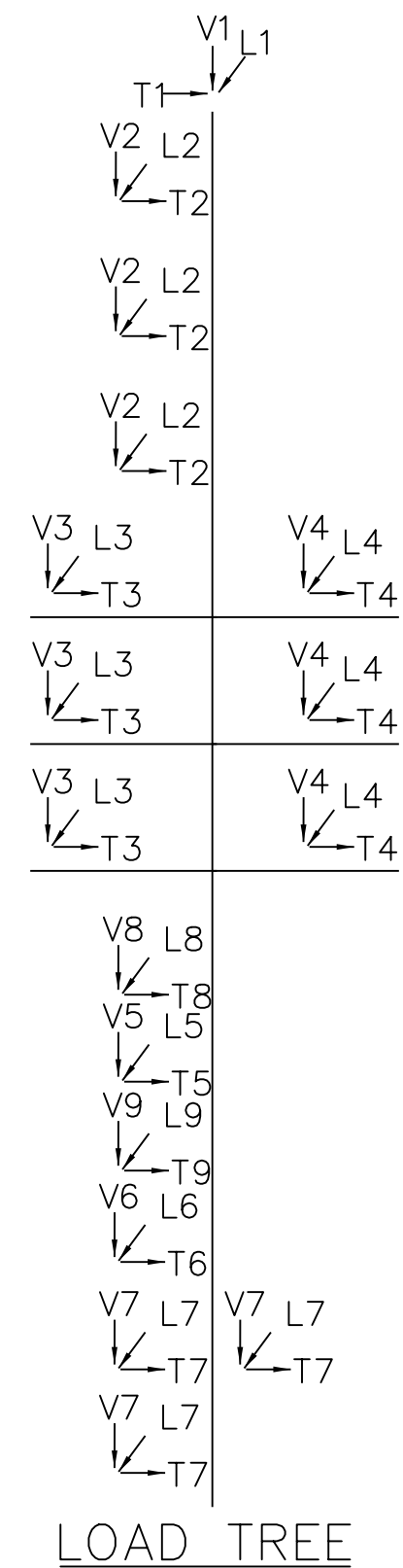

LOAD TREE

LOAD CASES

- CASE 1 NESM MEDIUM: 15°, .25" ICE, 4 PSF WIND
OLF: L=1.65, T=2.50, V=1.50
- CASE 2 NESM HIGH WIND: 60°, 0" ICE, 120 MPH WIND
OLF: L=1.00, T=1.00, V=1.00
- CASE 3 NESM ICE WITH WIND: 15°, 1" ICE, 40 MPH WIND
OLF: L=1.00, T=1.00, V=1.00
- CASE 4 NESM MEDIUM DEADEND: 15°, .25" ICE, 4 PSF WIND
OLF: L=1.65, T=2.50, V=1.50
- CASE 5 NESM HIGH WIND DEADEND: 60°, 0" ICE, 120 MPH WIND
OLF: L=1.00, T=1.00, V=1.00
- CASE 6 NESM ICE WITH WIND DEADEND: 15°, 1" ICE, 40 MPH WIND
OLF: L=1.00, T=1.00, V=1.00
- CASE 7 DEFLECTION: 60 DEGREES, NO ICE, NO WIND, FINAL
OLF: L=1.00, T=1.00, V=1.00
- CASE 10 STRINGING: -20°, 0" ICE, 2 PSF WIND
OLF: L=1.50, T=1.50, V=1.50

WIRE DATA

OHGW: "7#9" ALUMOWELD
115KV: 1272 KCMIL 61/0 STRAND "NARCISSUS" AAC
12.47KV: 336.4 KCMIL 18/1 STRAND "MERLIN" ACSR
DISTRIBUTION NEUTRAL: 336.4 KCMIL 18/1 STRAND "MERLIN" ACSR
ADSS: "AT-XXX27DT-144-CLCB" 144 FIBER

NOTES:

- ALL STATED LOADS ARE ULTIMATE VALUES AND INCLUDE OVERLOAD FACTORS AND INSULATOR WEIGHT.
- STRUCTURE AND ATTACHMENTS SHALL BE DESIGNED FOR THE SIMULTANEOUS APPLICATION OF DEAD LOAD, WIND ON THE STRUCTURE, AND WIRE LOADS FOR EACH LOADING CASE.
- STRUCTURE SHALL BE DESIGNED SELF SUPPORTING. GUYS ARE NOT PERMITTED. STRUCTURE SHALL MEET ALL TECHNICAL REQUIREMENTS OF THE STEEL POLE SPECIFICATIONS.
- WIND PRESSURES SHOWN ON LOAD WORKSHEET ARE BASED ON A SHAPE FACTOR OF 1.0.
- FABRICATOR MAY PROPOSE STRUCTURAL DETAILS DIFFERENT THAN THOSE SHOWN TO SIMPLIFY FABRICATION. VARIATIONS SHALL BE SUBMITTED TO ENGINEER IN WRITING.
- MINIMUM VANG PLATE THICKNESS = 1/2".
- WIND SHALL BE APPLIED IN THE DIRECTION WHICH RESULTS IN THE MOST SEVERE EFFECT.
- THE DEFLECTION AT THE POLE TOP SHALL BE LIMITED TO 1.5% OF THE POLE HEIGHT UNDER THE DEFLECTION CASE. POLES MAY BE CAMBERED TO FALL WITHIN THE DESIGN LIMIT.
- MAXIMUM DEFLECTION AT TOP OF THE STRUCTURE SHALL BE LIMITED TO 10% OF STRUCTURE HEIGHT UNDER ALL LOAD CASES WITH THE EXCEPTION TO THE 60° NO WIND LOAD CASE.
- POLE DESIGN AND FABRICATION SHALL INCLUDE PROVISIONS FOR A SLIP JOINT TO LIMIT LOWEST POLE SEGMENT EXTENSION ABOVE GRADE TO 12'-0" MAXIMUM.
- ALL STRUCTURES SHALL BE GALVANIZED STEEL.
- ORIENT SINGLE SIDED VANGS FOR HARDWARE SHOWN ON DRAWINGS.
- MANUFACTURER SHALL APPLY POINT LOADS NECESSARY TO CREATE THE MOST SEVERE EFFECTS ON ALL MEMBERS INCLUDING ARMS, POLES, BASE PLATES, ETC.

NO.	REVISIONS
A	MT. PLEASANT TO SUGG T-LINE ISSUED FOR BID ENGINEER'S S.E DATE: 12/03/21

CONSTRUCTION NOTE:
REMOVE OLD WIRE LABELS WITH ORANGE TEXT,
INSTALL NEW WIRE LABELS WITH GREEN TEXT

ISSUED FOR BID

GREENVILLE UTILITIES
Greenville, North Carolina

115KV TRANSMISSION LINE
MT. PLEASANT SUB TO SUGG
LOAD AND DESIGN
DEADEND 60°-90° WITH UNDERBUILD

DW.D. CHAMBLISS DATE 12/03/21 DWG. NO.
CKD. R. DILLABOUGH APPD. S. ECKMAN DE-90R_STR-62
SCALE: NONE

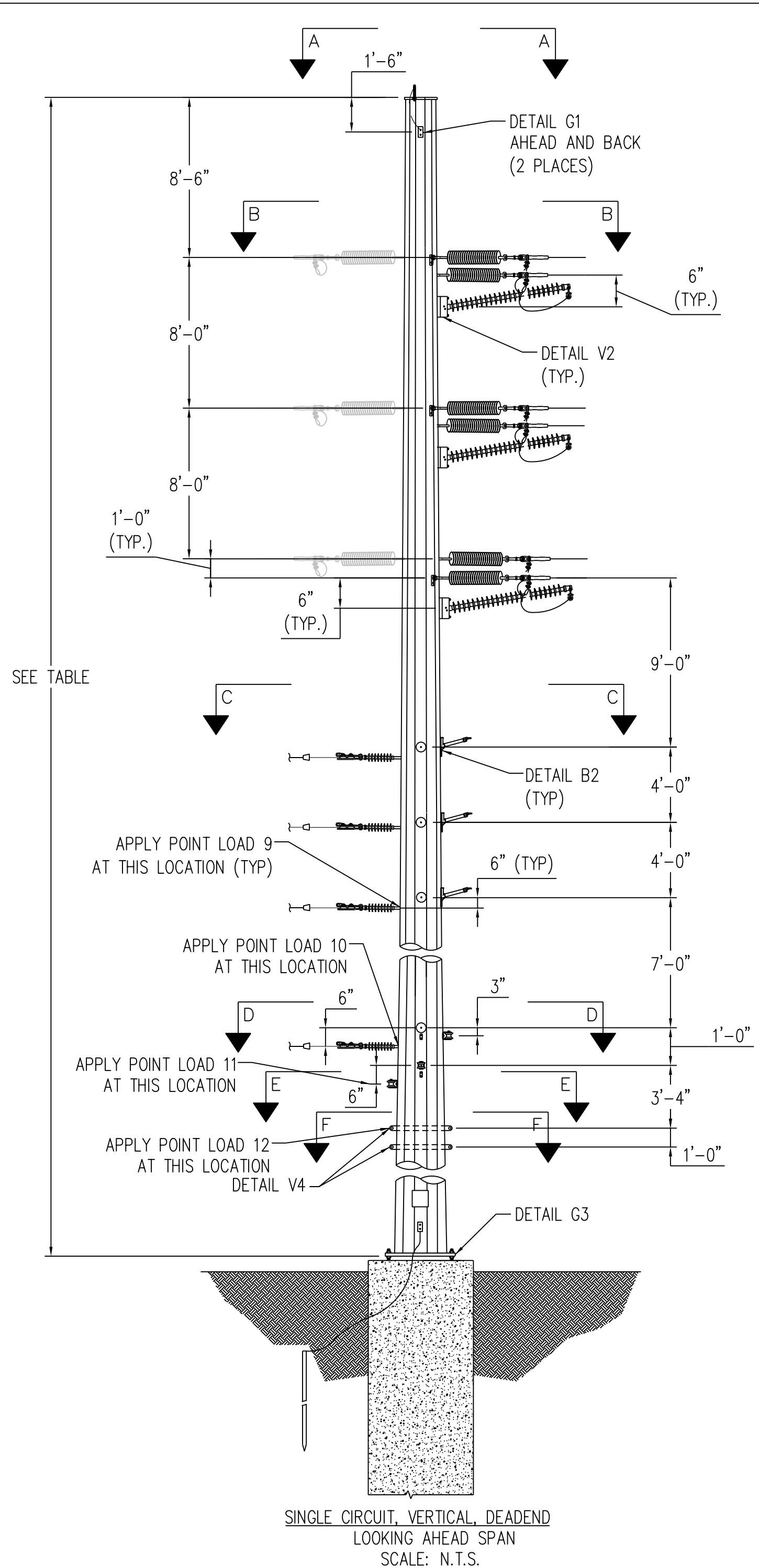

SEE TABLE

SINGLE CIRCUIT, VERTICAL, DEADEND
LOOKING AHEAD SPAN
SCALE: N.T.S.

STR #	LENGTH (FT)	ANGLE Δ
99	85	69

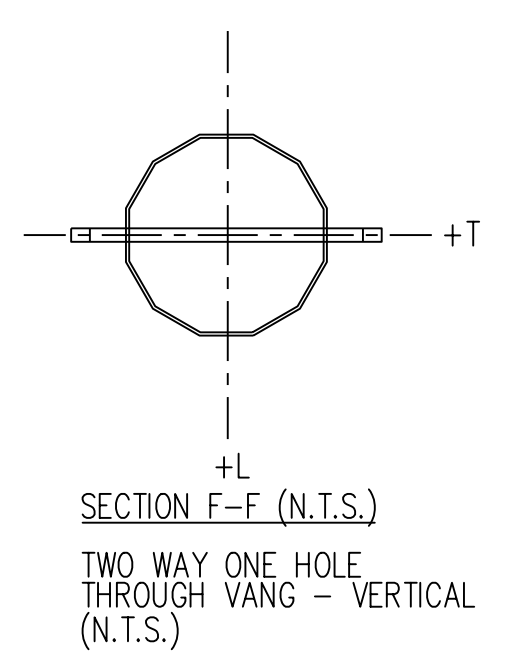
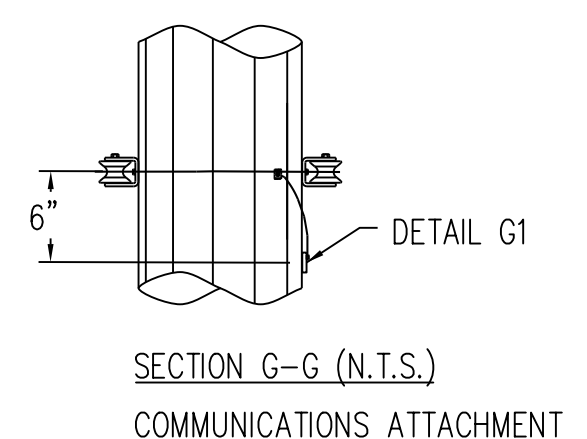
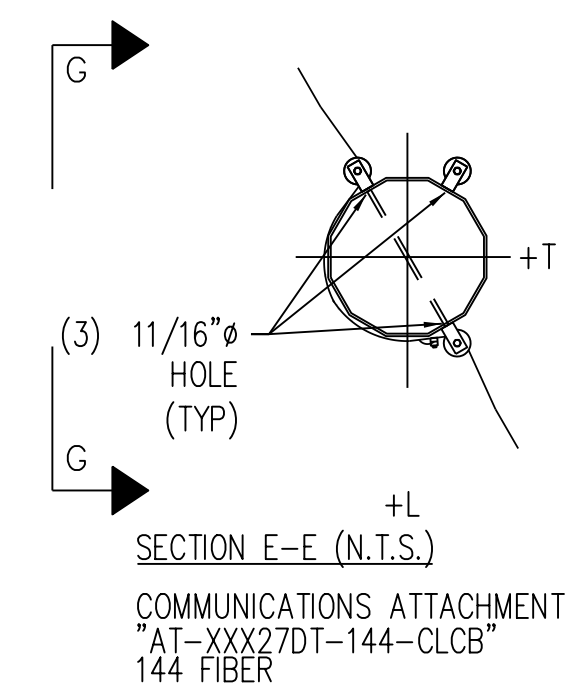
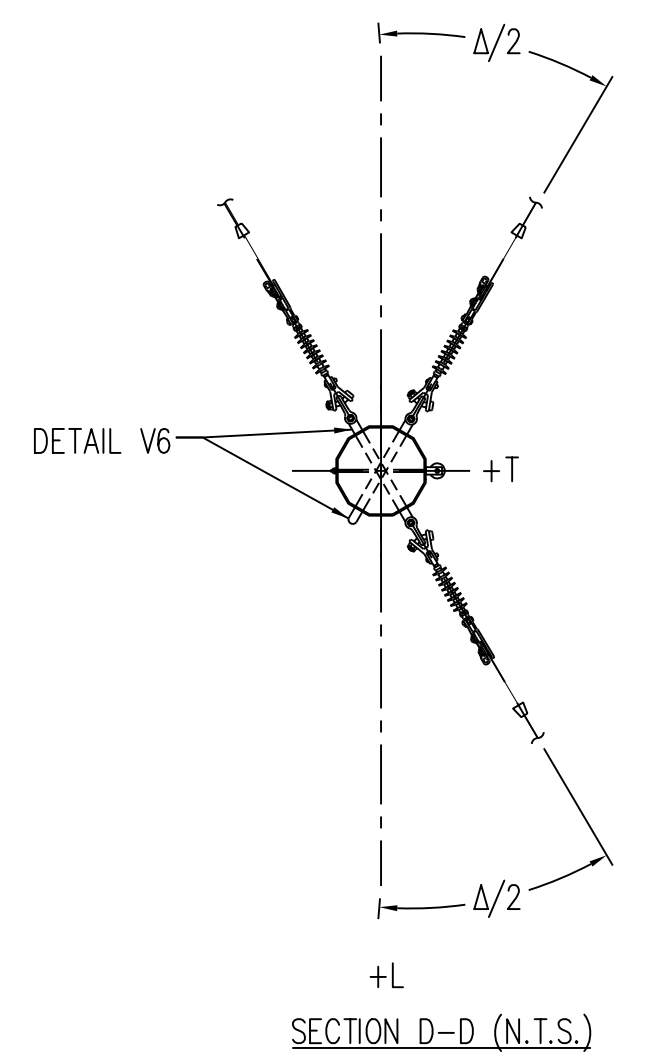
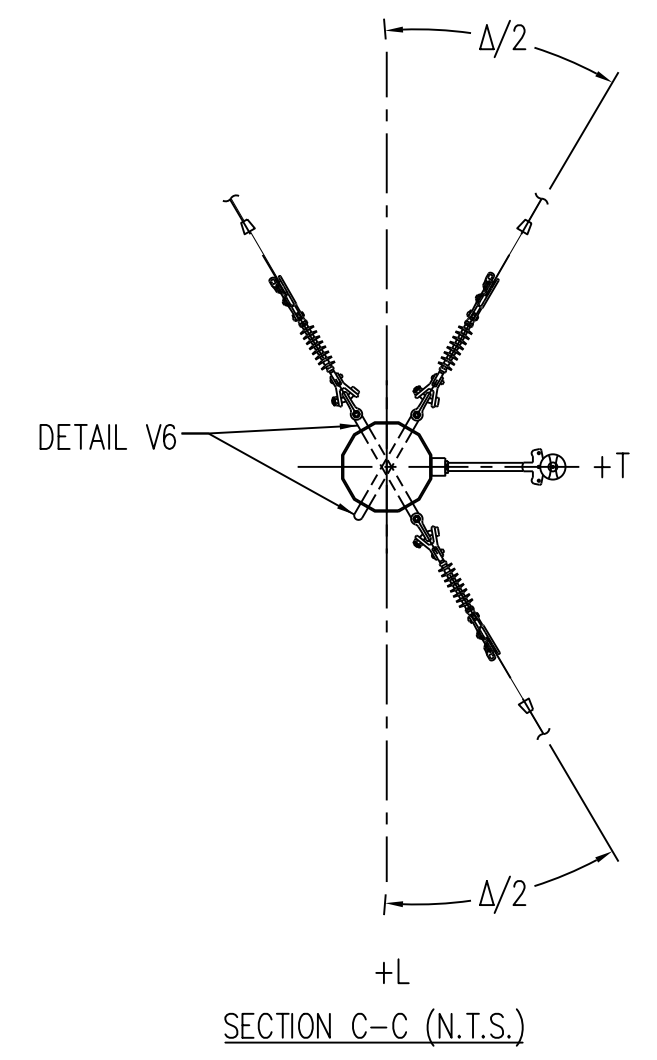
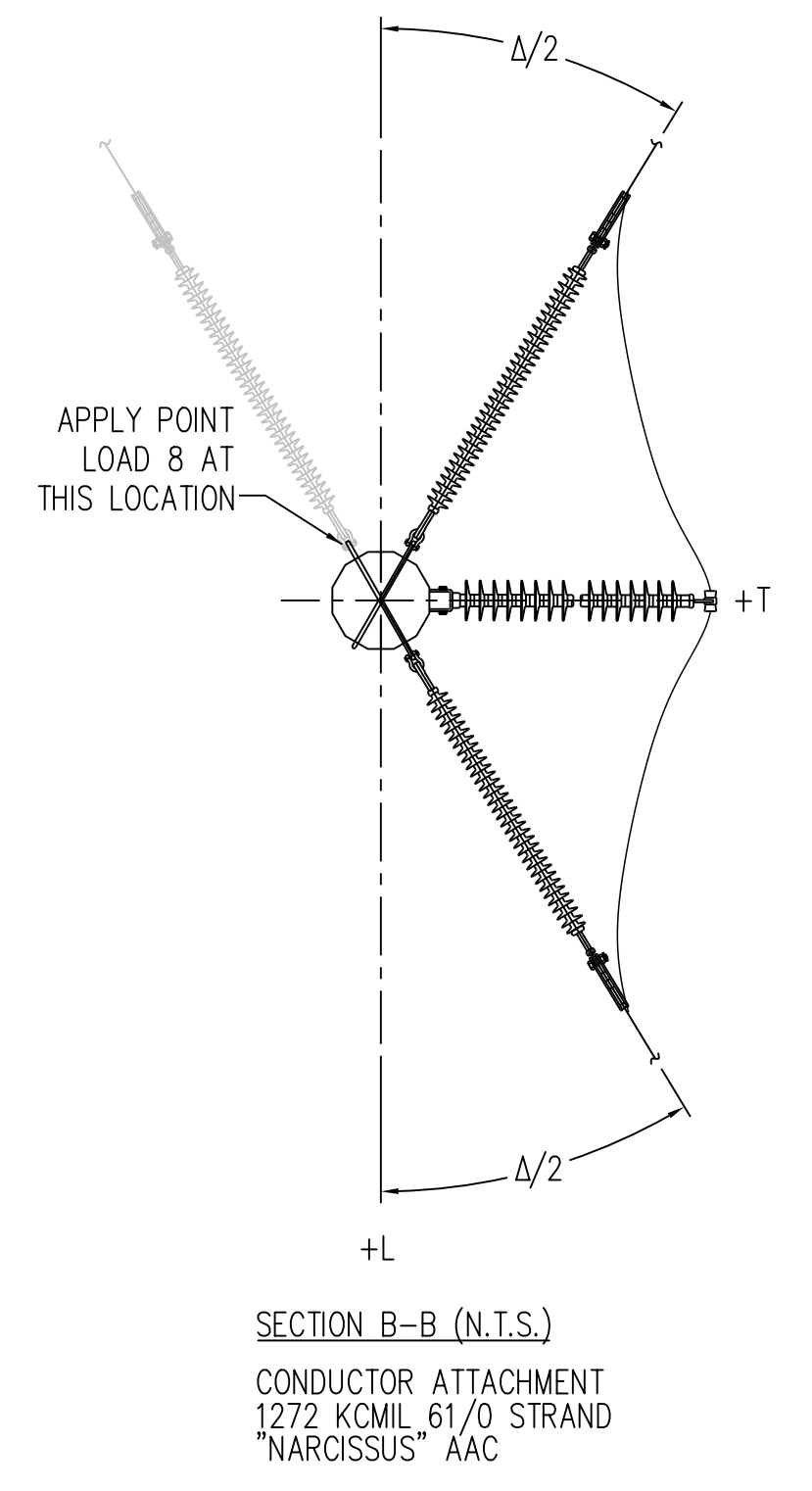
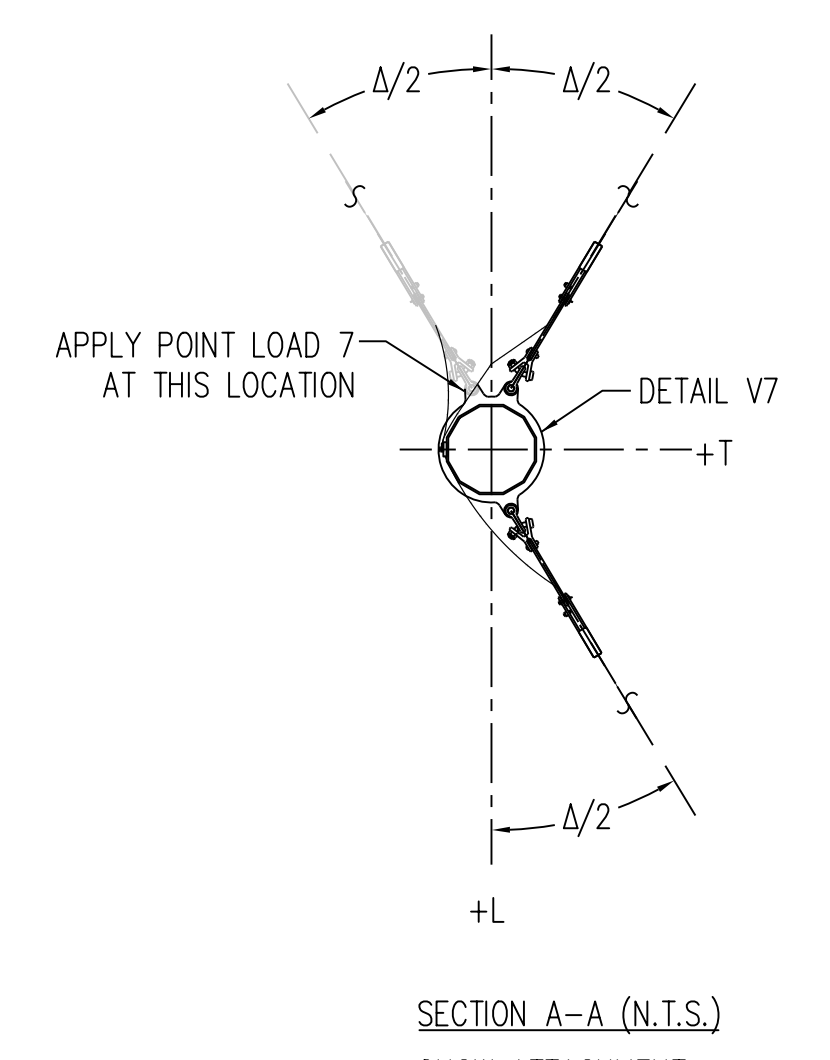

LOAD	LOADING TABLE									
	CASE 1	CASE 2	CASE 3	CASE 4	CASE 5	CASE 6	CASE 7	CASE 10		
V1	300	200	700	200	100	400	100	200		
T1	3900	5800	3800	2000	2900	1900	700	2500		
L1	-100	-100	-100	-2200	-1500	-2500	-100	-100		
V2	1100	700	1500	700	400	800	500	1100		
T2	16700	18000	12000	8400	9000	6100	3500	16600		
L2	-400	-300	-400	-10500	-6500	-8100	-100	-400		
V3	400	200	800	200	100	400	200	2800		
T3	7200	7500	5800	3700	3800	3000	1300	6200		
L3	-300	-200	-200	-4600	-3100	-3900	-100	-800		
V4	200	100	500	100	100	300	100	100		
T4	3900	5200	3400	2000	2600	1700	800	2900		
L4	-100	-100	-100	-2200	-1500	-2200	-100	-100		
V5	200	100	700	100	100	400	100	100		
T5	2100	2200	2200	1100	1100	1100	800	1200		
L5	-100	-100	-100	-1500	-1500	-1500	-	-100		
V6	100	100	200	100	100	200	100	100		
T6	1600	1000	1300	1600	1000	1300	400	1600		
L6	-1700	-1000	-1400	-1700	-1000	-1400	-500	-1700		
V7	500	200	1500	600	200	1600	200	300		
T7	-3900	-1900	-2500	-3900	-1900	-2500	-1700	-4500		
L7	-3500	-1900	-2300	-3500	-1900	-2300	-1400	-3800		
V8	2200	1000	3400	2300	1100	3700	1000	1700		
T8	-7300	-2700	-5000	-7300	-2700	-5000	-1600	-10100		
L8	-6500	-3200	-4500	-6500	-3200	-4500	-1400	-8700		
V9	600	300	1400	700	300	1600	300	400		
T9	-3000	-1300	-2300	-3000	-1300	-2300	-600	-4000		
L9	-2800	-1500	-2100	-2800	-1500	-2100	-600	-3500		
V10	400	100	1100	400	100	1200	100	200		
T10	-1500	-700	-1200	-1500	-700	-1200	-500	-1800		
L10	-1400	-800	-1200	-1400	-800	-1200	-400	-1600		
V11	500	200	1400	600	200	1600	200	300		
T11	-800	-300	-700	-800	-300	-700	-500	-700		
L11	-900	-700	-800	-900	-700	-800	-500	-700		
V12	1600	600	3600	1700	600	3900	600	900		
T12	-2700	-1400	-2700	-2700	-1400	-2700	-1300	-2500		
L12	-2800	-2500	-2700	-2800	-2500	-2700	-1100	-2500		
W(Psf)	10	36.9	4.1	10	36.9	4.1	0	3		

ALL LOADS ARE IN LBS, ARE ULTIMATE, AND INCLUDE ALL OVERLOAD FACTORS. "W" REPRESENTS WIND PRESSURE (psf) TO BE APPLIED TO STRUCTURE.

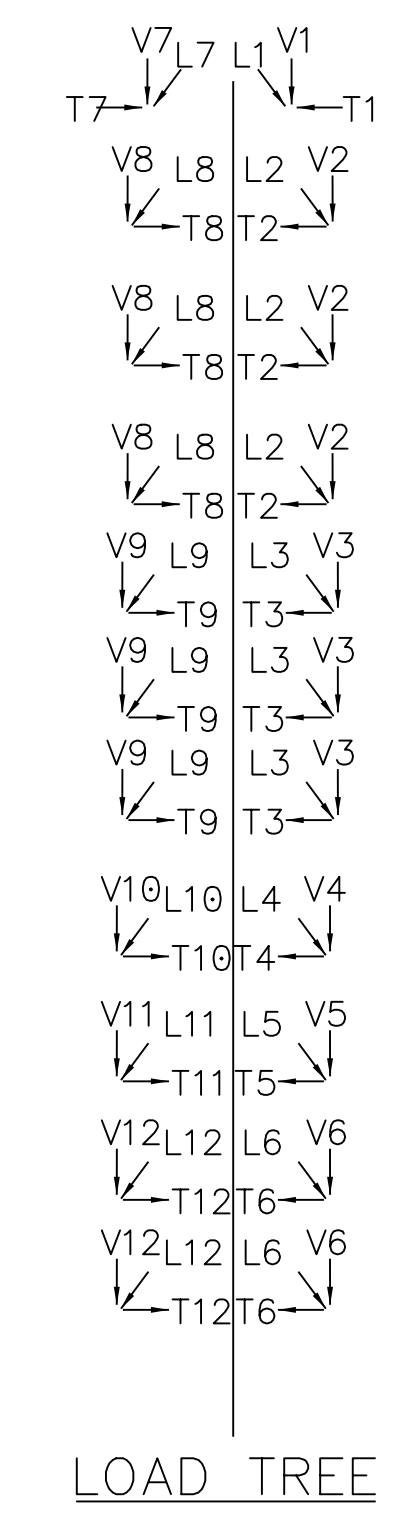

LOAD CASES

- CASE 1 NESM MEDIUM: 15°, .25" ICE, 4 PSF WIND
OLF: L=1.65, T=2.50, V=1.50
- CASE 2 NESM HIGH WIND: 60°, 0" ICE, 120 MPH WIND
OLF: L=1.00, T=1.00, V=1.00
- CASE 3 NESM ICE WITH WIND: 15°, 1" ICE, 40 MPH WIND
OLF: L=1.00, T=1.00, V=1.00
- CASE 4 NESM MEDIUM DEADEND: 15°, .25" ICE, 4 PSF WIND
OLF: L=1.65, T=2.50, V=1.50
- CASE 5 NESM HIGH DEADEND: 60°, 0" ICE, 120 MPH WIND
OLF: L=1.00, T=1.00, V=1.00
- CASE 6 NESM ICE WITH WIND DEADEND: 15°, 1" ICE, 40 MPH WIND
OLF: L=1.00, T=1.00, V=1.00
- CASE 7 DEFLECTION: 60 DEGREES, NO ICE, NO WIND, FINAL
OLF: L=1.00, T=1.00, V=1.00
- CASE 10 STRINGING: -20°, 0" ICE, 2 PSF WIND
OLF: L=1.50, T=1.50, V=1.50

WIRE DATA

OHGW: "7#9" ALUMOWELD
115KV: 1272 KCMIL 61/0 STRAND "NARCISSUS" AAC
12.47KV: 336.4 KCMIL 18/1 STRAND "MERLIN" ACSR
DISTRIBUTION NEUTRAL: 1/0 6/1 STRAND "RAVEN" ACSR
ADSS: "AT-XXX27DT-144-CLCB" 144 FIBER

NOTES:

- ALL STATED LOADS ARE ULTIMATE VALUES AND INCLUDE OVERLOAD FACTORS AND INSULATOR WEIGHT.
- STRUCTURE AND ATTACHMENTS SHALL BE DESIGNED FOR THE SIMULTANEOUS APPLICATION OF DEAD LOAD, WIND ON THE STRUCTURE, AND WIRE LOADS FOR EACH LOADING CASE.
- STRUCTURE SHALL BE DESIGNED SELF SUPPORTING, GUYS ARE NOT PERMITTED. STRUCTURE SHALL MEET ALL TECHNICAL REQUIREMENTS OF THE STEEL POLE SPECIFICATIONS.
- WIND PRESSURES SHOWN ON LOAD WORKSHEET ARE BASED ON A SHAPE FACTOR OF 1.0.
- FABRICATOR MAY PROPOSE STRUCTURAL DETAILS DIFFERENT THAN THOSE SHOWN TO SIMPLIFY FABRICATION. VARIATIONS SHALL BE SUBMITTED TO ENGINEER IN WRITING.
- MINIMUM VANG PLATE THICKNESS = 1/2".
- WIND SHALL BE APPLIED IN THE DIRECTION WHICH RESULTS IN THE MOST SEVERE EFFECT.
- THE DEFLECTION AT THE POLE TOP SHALL BE LIMITED TO 1.5% OF THE POLE HEIGHT UNDER THE DEFLECTION CASE. POLES MAY BE CAMBERED TO FALL WITHIN THE DESIGN LIMIT.
- MAXIMUM DEFLECTION AT TOP OF THE STRUCTURE SHALL BE LIMITED TO 10% OF STRUCTURE HEIGHT UNDER ALL LOAD CASES WITH THE EXCEPTION TO THE 60° NO WIND LOAD CASE.
- POLE DESIGN AND FABRICATION SHALL INCLUDE PROVISIONS FOR A SLIP JOINT TO LIMIT LOWEST POLE SEGMENT EXTENSION ABOVE GRADE TO 12'-0" MAXIMUM.
- ALL STRUCTURES SHALL BE GALVANIZED STEEL.
- ORIENT SINGLE SIDED VANGS FOR HARDWARE SHOWN ON DRAWINGS.
- MANUFACTURER SHALL APPLY POINT LOADS NECESSARY TO CREATE THE MOST SEVERE EFFECTS ON ALL MEMBERS INCLUDING ARMS, POLES, BASE PLATES, ETC.

NO.	REVISIONS
A	MT. PLEASANT TO SUGG T-LINE ISSUED FOR BID ENGINEERS: S.E DATE: 12/03/21

CONSTRUCTION NOTE:
REMOVE OLD WIRE LABELS WITH ORANGE TEXT,
INSTALL NEW WIRE LABELS WITH GREEN TEXT

ISSUED FOR BID

GREENVILLE UTILITIES
Greenville, North Carolina

115KV TRANSMISSION LINE
MT. PLEASANT SUB TO SUGG
LOAD AND DESIGN
DEADEND 60'-90' WITH UNDERBUILD

DWIND, CHAMBLISS DATE 12/03/21 DWG. NO.
CKD, R. DILLABOUGH APPD. S. ECKMAN DE-90R_STR-99
SCALE: NONE

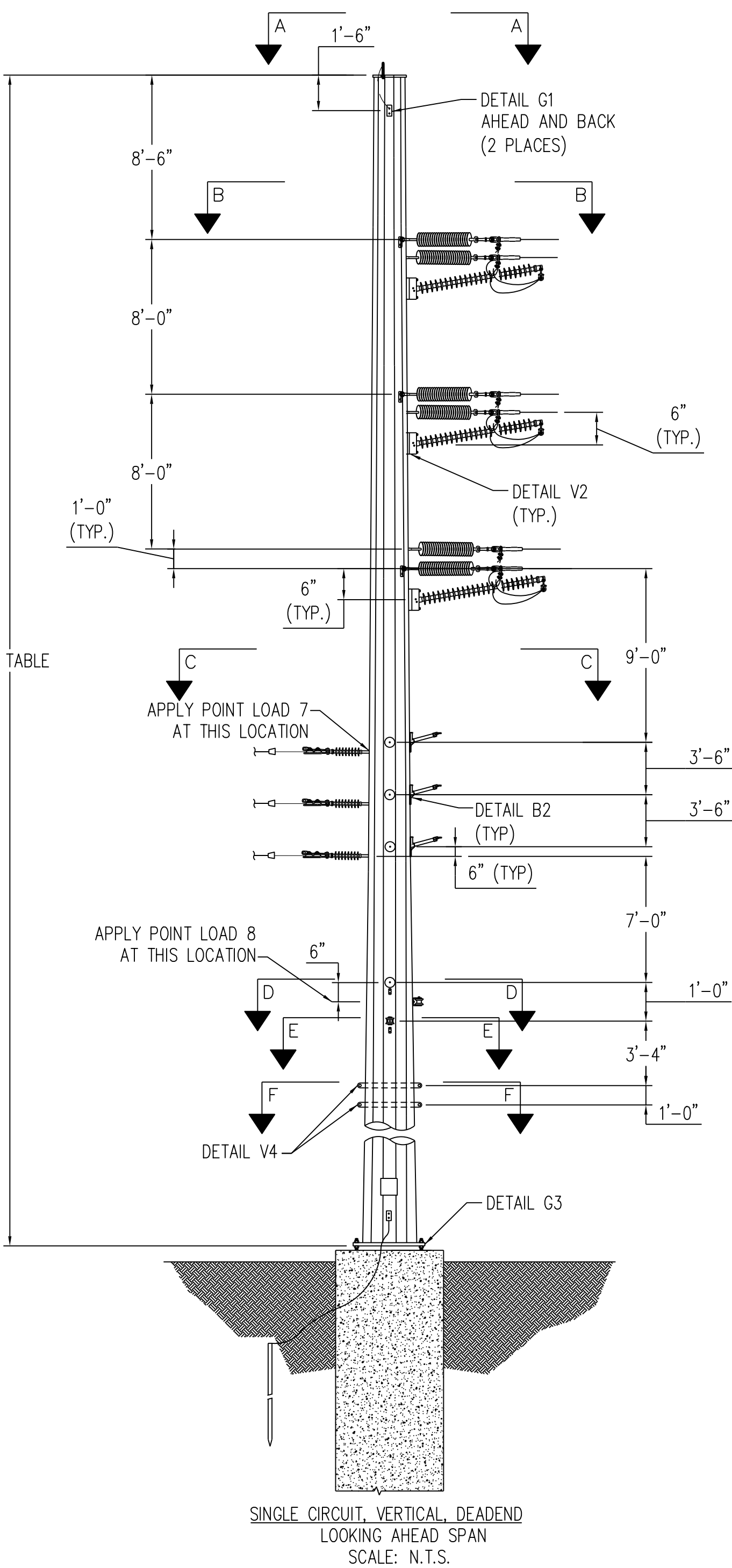

STR #	LENGTH (FT)	ANGLE Δ
132	75	68

LOAD	LOADING TABLE									
	CASE 1	CASE 2	CASE 3	CASE 4	CASE 5	CASE 6	CASE 7	CASE 10		
V1	-100	-100	200	-100	-100	100	-100	100		
T1	3700	5600	3600	1900	2800	1800	700	2500		
L1	100	100	100	2200	1500	2500	-100	100		
V2	-500	-500	200	-400	-300	200	-100	900		
T2	14200	16200	10400	7600	8300	5500	2900	14200		
L2	1700	800	900	10500	6400	8000	-400	1700		
V3	-200	-300	100	-200	-200	100	-100	2100		
T3	6600	6900	5300	3400	3500	2700	1200	5800		
L3	200	100	100	4500	2900	3800	-100	600		
V4	-100	-200	100	-100	-100	100	-100	200		
T4	3800	5000	3300	1900	2500	1700	800	2900		
L4	100	100	100	2200	1500	2100	-100	100		
V5	-100	-100	300	-100	-100	200	-100	100		
T5	2000	2000	2000	1000	1000	1100	800	1200		
L5	100	100	100	1400	1400	1500	-	100		
V6	-200	-200	300	-100	-100	200	-100	100		
T6	1800	2500	2500	1000	1300	1300	400	700		
L6	100	100	100	1400	1800	1900	-100	100		
V7	500	200	1200	-	-	-	200	300		
T7	-1700	-700	-1400	-	-	-	-400	-2200		
L7	-4200	-2400	-3300	-	-	-	-900	-5000		
V8	300	100	900	-	-	-	100	200		
T8	-800	-400	-700	-	-	-	-300	-1000		
L8	-2100	-1300	-1900	-	-	-	-600	-2200		
W(PSF)	10	36.9	4.1	10	36.9	4.1	0	3		

ALL LOADS ARE IN LBS, ARE ULTIMATE, AND INCLUDE ALL OVERLOAD FACTORS. "W" REPRESENTS WIND PRESSURE (psf) TO BE APPLIED TO STRUCTURE.

LOAD CASES

- CASE 1 NESM MEDIUM: 15", .25" ICE, 4 PSF WIND
OLF: L=1.65, T=2.50, V=1.50
- CASE 2 NESM HIGH WIND: 60°, 0" ICE, 120 MPH WIND
OLF: L=1.00, T=1.00, V=1.00
- CASE 3 NESM ICE WITH WIND: 15", 1" ICE, 40 MPH WIND
OLF: L=1.00, T=1.00, V=1.00
- CASE 4 NESM MEDIUM DEADEND: 15", .25" ICE, 4 PSF WIND
OLF: L=1.65, T=2.50, V=1.50
- CASE 5 NESM HIGH WIND DEADEND: 60°, 0" ICE, 120 MPH WIND
OLF: L=1.00, T=1.00, V=1.00
- CASE 6 NESM ICE WITH WIND DEADEND: 15", 1" ICE, 40 MPH WIND
OLF: L=1.00, T=1.00, V=1.00
- CASE 7 DEFLECTION: 60 DEGREES, NO ICE, NO WIND, FINAL
OLF: L=1.00, T=1.00, V=1.00
- CASE 10 STRINGING: -20°, 0" ICE, 2 PSF WIND
OLF: L=1.50, T=1.50, V=1.50

WIRE DATA

OHGW: "7#9" ALUMOWELD
 115KV: 1272 KCMIL 61/0 STRAND "NARCISSUS" AAC
 12.47KV: 336.4 KCMIL 18/1 STRAND "MERLIN" ACSR
 DISTRIBUTION NEUTRAL: 1/0 6/1 STRAND "RAVEN" ACSR
 ADSS: "AT-XXX27DT-144-CLCB" 144 FIBER

NOTES:

- ALL STATED LOADS ARE ULTIMATE VALUES AND INCLUDE OVERLOAD FACTORS AND INSULATOR WEIGHT.
- STRUCTURE AND ATTACHMENTS SHALL BE DESIGNED FOR THE SIMULTANEOUS APPLICATION OF DEAD LOAD, WIND ON THE STRUCTURE, AND WIRE LOADS FOR EACH LOADING CASE.
- STRUCTURE SHALL BE DESIGNED SELF SUPPORTING, GUYS ARE NOT PERMITTED. STRUCTURE SHALL MEET ALL TECHNICAL REQUIREMENTS OF THE STEEL POLE SPECIFICATIONS.
- WIND PRESSURES SHOWN ON LOAD WORKSHEET ARE BASED ON A SHAPE FACTOR OF 1.0.
- FABRICATOR MAY PROPOSE STRUCTURAL DETAILS DIFFERENT THAN THOSE SHOWN TO SIMPLIFY FABRICATION. VARIATIONS SHALL BE SUBMITTED TO ENGINEER IN WRITING.
- MINIMUM VANG PLATE THICKNESS = 1/2".
- WIND SHALL BE APPLIED IN THE DIRECTION WHICH RESULTS IN THE MOST SEVERE EFFECT.
- THE DEFLECTION AT THE POLE TOP SHALL BE LIMITED TO 1.5% OF THE POLE HEIGHT UNDER THE DEFLECTION CASE. POLES MAY BE CAMBERED TO FALL WITHIN THE DESIGN LIMIT.
- MAXIMUM DEFLECTION AT TOP OF THE STRUCTURE SHALL BE LIMITED TO 10% OF STRUCTURE HEIGHT UNDER ALL LOAD CASES WITH THE EXCEPTION TO THE 60°F NO WIND LOAD CASE.
- POLE DESIGN AND FABRICATION SHALL INCLUDE PROVISIONS FOR A SLIP JOINT TO LIMIT LOWEST POLE SEGMENT EXTENSION ABOVE GRADE TO 12'-0" MAXIMUM.
- ALL STRUCTURES SHALL BE GALVANIZED STEEL.
- ORIENT SINGLE SIDED VANGS FOR HARDWARE SHOWN ON DRAWINGS.
- MANUFACTURER SHALL APPLY POINT LOADS NECESSARY TO CREATE THE MOST SEVERE EFFECTS ON ALL MEMBERS INCLUDING ARMS, POLES, BASE PLATES, ETC.

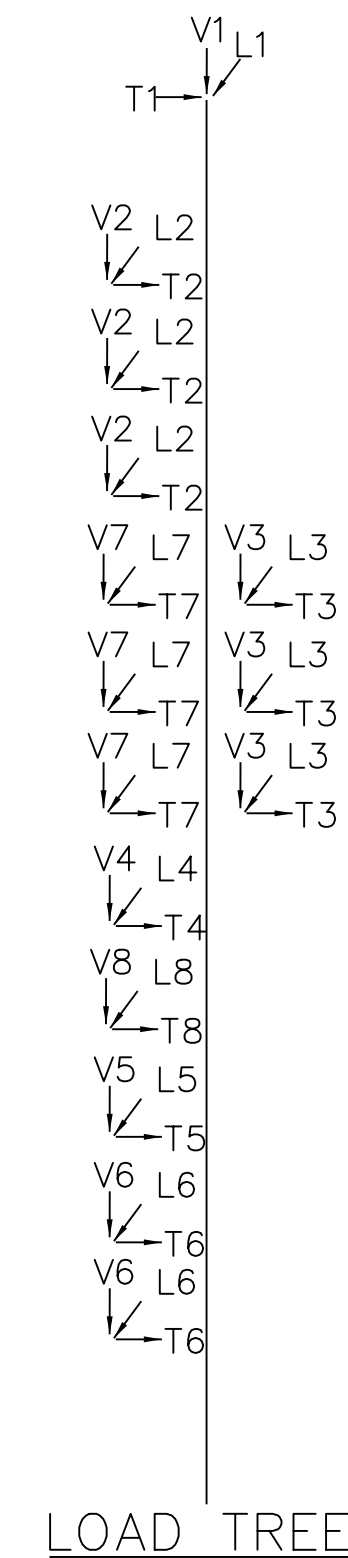
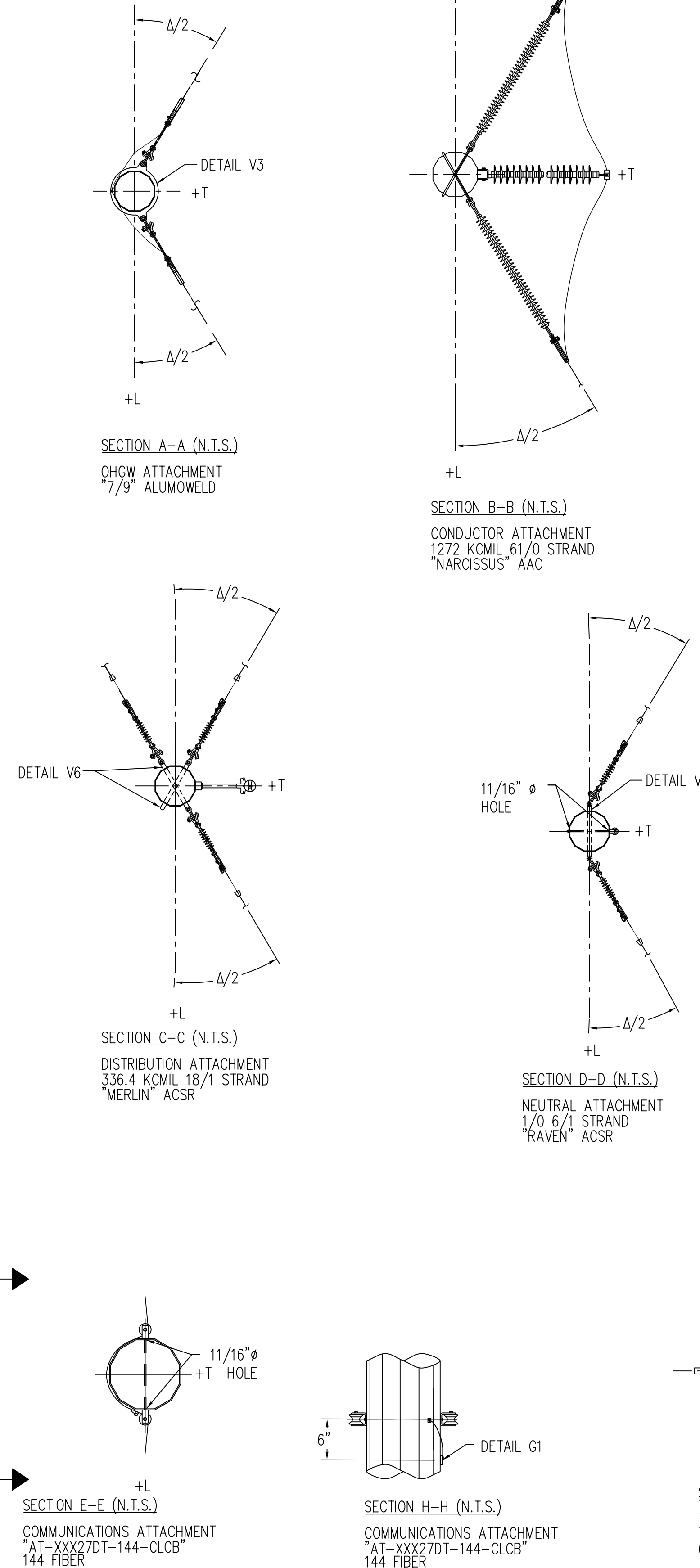

NO.	A
REVISIONS	MT. PLEASANT TO SUGG T-LINE ISSUED FOR BID ENGINEERS: S.E DATE: 12/03/21

CONSTRUCTION NOTE:
 REMOVE OLD WIRE LABELS WITH ORANGE TEXT,
 INSTALL NEW WIRE LABELS WITH GREEN TEXT

ISSUED FOR BID

GREENVILLE UTILITIES
 Greenville, North Carolina

115KV TRANSMISSION LINE
 MT. PLEASANT SUB TO SUGG
 LOAD AND DESIGN
 DEADEND 60"-90" WITH UNDERBUILD

DW.D. CHAMBLISS DATE 12/03/21 DWG. NO. DE-90R_STR-132
 CKD. R. DILLABOUGH APPD. S. ECKMAN SCALE: NONE

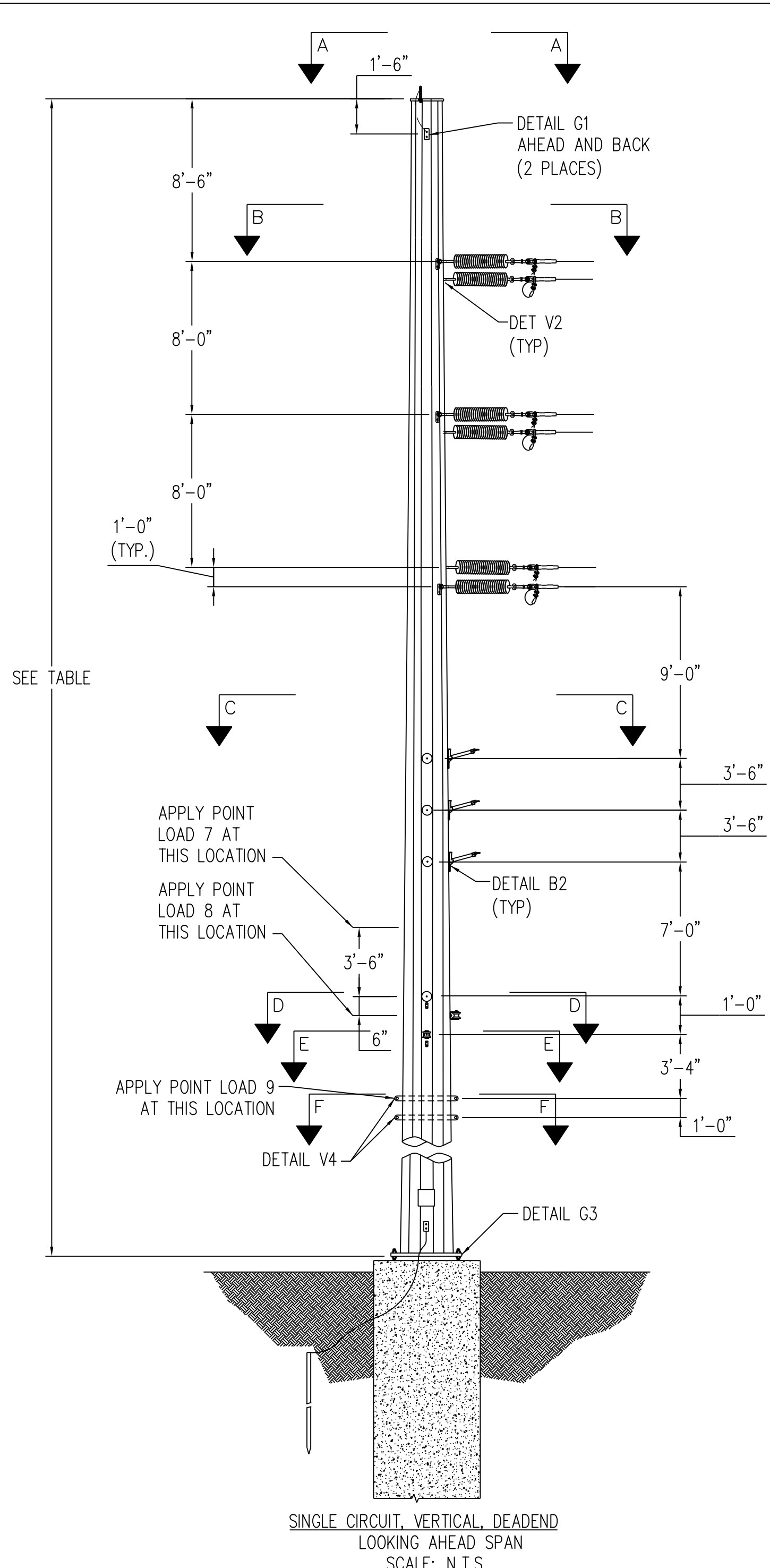

SEE TABLE

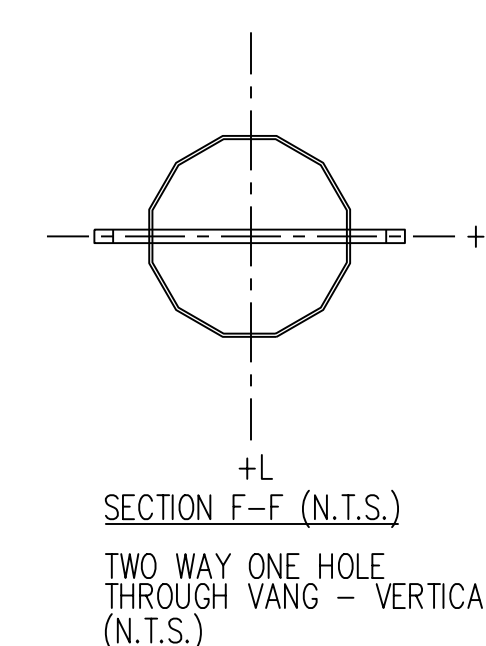
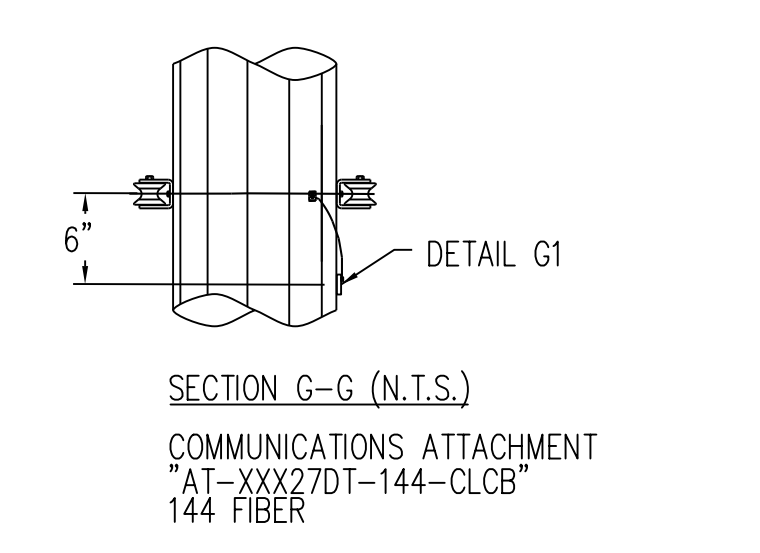
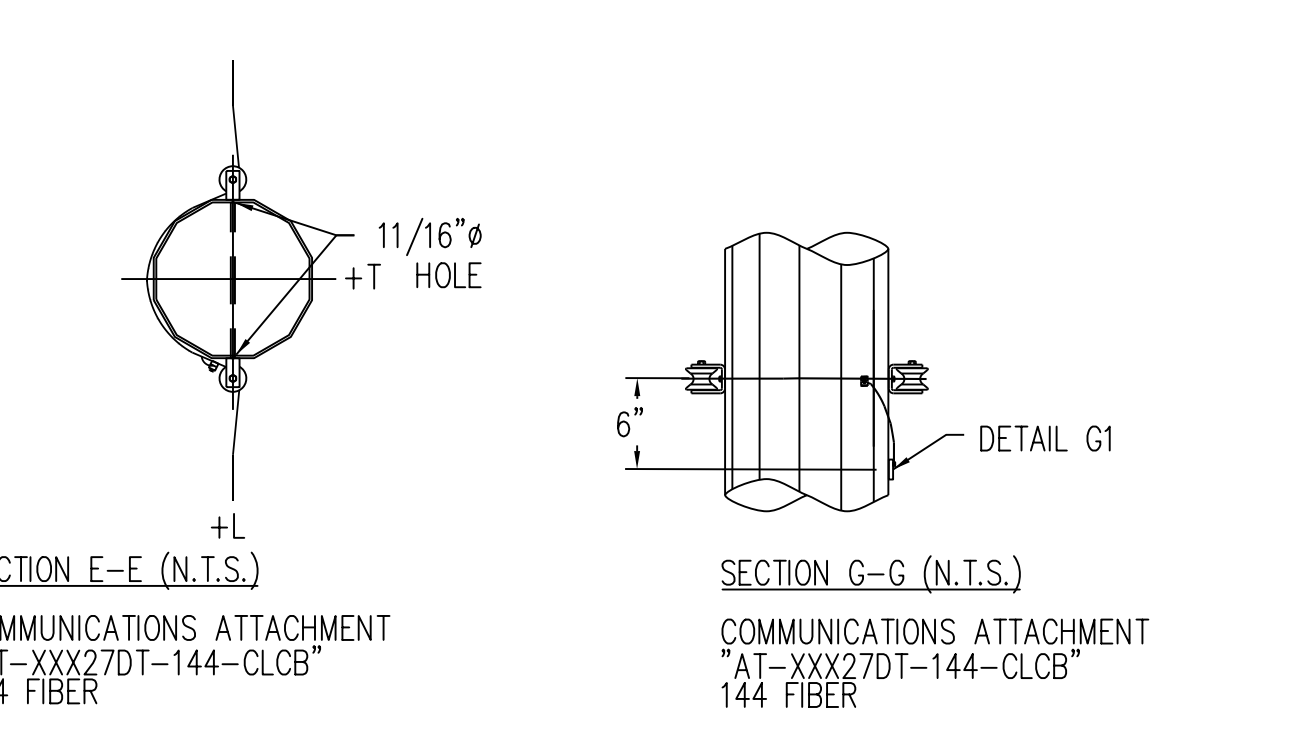
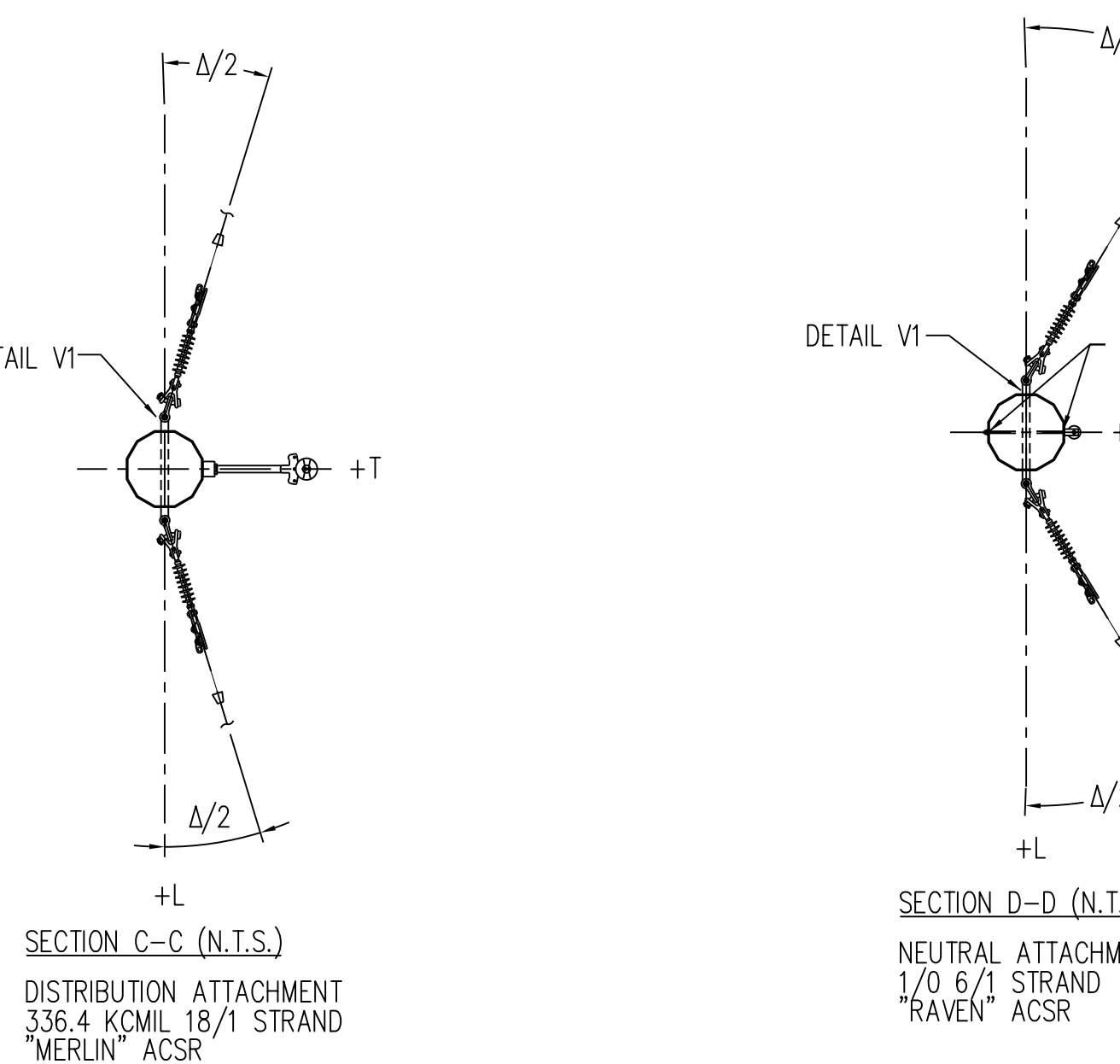
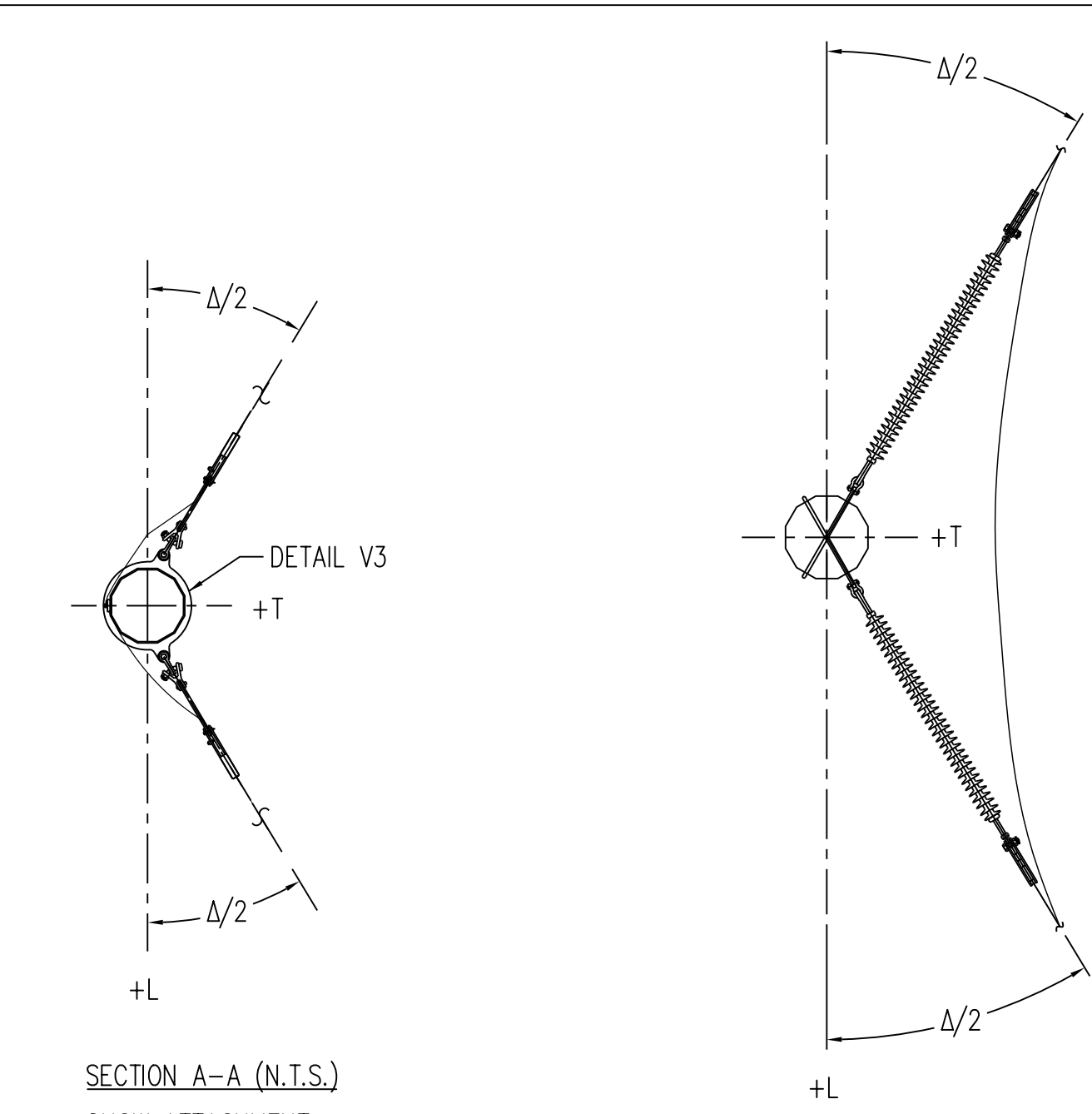

STR #	LENGTH (FT)	ANGLE Δ
153	85	91

LOAD	LOADING TABLE									
	CASE 1	CASE 2	CASE 3	CASE 4	CASE 5	CASE 6	CASE 7	CASE 10		
V1	100	100	400	100	100	200	100	100		
T1	6100	6900	5100	3900	4000	3200	1700	5300		
L1	-1600	-1100	-1300	-3500	-2200	-3000	-700	-1400		
V2	400	100	700	300	200	400	200	100		
T2	19000	19000	13600	10500	10700	7900	3900	19500		
L2	-1400	-2000	-1700	-9400	-6300	-7400	-700	-500		
V3	200	100	400	100	100	300	100	2600		
T3	8300	8000	6600	4600	4600	3900	1500	7500		
L3	-900	-1000	-1100	-4200	-2900	-3700	-400	-800		
V4	100	100	400	100	100	200	100	100		
T4	4500	5500	3900	2500	3000	2300	900	3500		
L4	-400	-500	-600	-2100	-1500	-2100	-100	-100		
V5	200	100	500	100	100	400	100	100		
T5	2400	2400	2500	1400	1500	1500	1000	1500		
L5	-400	-500	-500	-1400	-1500	-1500	-	-100		
V6	200	200	500	200	200	500	100	200		
T6	1200	1500	1400	1200	1500	1400	300	500		
L6	-1200	-1500	-1500	-1200	-1500	-1500	-300	-600		
V7	-	-	-	500	200	1800	200	300		
T7	-	-	-	1400	700	1300	500	1700		
L7	-	-	-	-1600	-1000	-1400	-500	1700		
V8	-	-	-	500	200	1800	200	300		
T8	-	-	-	1400	700	1300	500	1700		
L8	-	-	-	-1600	-1000	-1400	500	1700		
V9	-	-	-	1300	500	3000	400	700		
T9	-	-	-	-700	500	-1100	300	300		
L9	-	-	-	1100	1300	1400	300	600		
W(PSF)	10	36.9	4.1	10	36.9	4.1	0	3		

ALL LOADS ARE IN LBS, ARE ULTIMATE, AND INCLUDE ALL OVERLOAD FACTORS. "W" REPRESENTS WIND PRESSURE (psf) TO BE APPLIED TO STRUCTURE.

LOAD CASES

- CASE 1 NESM MEDIUM: 15°, .25" ICE, 4 PSF WIND
OLF: L=1.65, T=2.50, V=1.50
- CASE 2 NESM HIGH WIND: 60°, 0" ICE, 120 MPH WIND
OLF: L=1.00, T=1.00, V=1.00
- CASE 3 NESM ICE WITH WIND: 15°, 1" ICE, 40 MPH WIND
OLF: L=1.00, T=1.00, V=1.00
- CASE 4 NESM MEDIUM DEADEND: 15°, .25" ICE, 4 PSF WIND
OLF: L=1.65, T=2.50, V=1.50
- CASE 5 NESM HIGH WIND DEADEND: 60°, 0" ICE, 120 MPH WIND
OLF: L=1.00, T=1.00, V=1.00
- CASE 6 NESM ICE WITH WIND DEADEND: 15°, 1" ICE, 40 MPH WIND
OLF: L=1.00, T=1.00, V=1.00
- CASE 7 DEFLECTION: 60 DEGREES, NO ICE, NO WIND, FINAL
OLF: L=1.00, T=1.00, V=1.00
- CASE 10 STRINGING: -20°, 0" ICE, 2 PSF WIND
OLF: L=1.50, T=1.50, V=1.50

WIRE DATA

OHGW: "7#9" ALUMOWELD
115KV: 1272 KCMIL 61/0 STRAND "NARCISSUS" AAC
12.47KV: 336.4 KCMIL 18/1 STRAND "RAVEN" ACSR
DISTRIBUTION NEUTRAL: 1/0 6/1 STRAND "RAVEN" ACSR
ADSS: "AT-XXX27DT-144-CLCB" 144 FIBER

NOTES:

- ALL STATED LOADS ARE ULTIMATE VALUES AND INCLUDE OVERLOAD FACTORS AND INSULATOR WEIGHT.
- STRUCTURE AND ATTACHMENTS SHALL BE DESIGNED FOR THE SIMULTANEOUS APPLICATION OF DEAD LOAD, WIND ON THE STRUCTURE, AND WIRE LOADS FOR EACH LOADING CASE.
- STRUCTURE SHALL BE DESIGNED SELF SUPPORTING, GUYS ARE NOT PERMITTED. STRUCTURE SHALL MEET ALL TECHNICAL REQUIREMENTS OF THE STEEL POLE SPECIFICATIONS.
- WIND PRESSURES SHOWN ON LOAD WORKSHEET ARE BASED ON A SHAPE FACTOR OF 1.0.
- FABRICATOR MAY PROPOSE STRUCTURAL DETAILS DIFFERENT THAN THOSE SHOWN TO SIMPLIFY FABRICATION. VARIATIONS SHALL BE SUBMITTED TO ENGINEER IN WRITING.
- MINIMUM VANG PLATE THICKNESS = 1/2".
- WIND SHALL BE APPLIED IN THE DIRECTION WHICH RESULTS IN THE MOST SEVERE EFFECT.
- THE DEFLECTION AT THE POLE TOP SHALL BE LIMITED TO 1.5% OF THE POLE HEIGHT UNDER THE DEFLECTION CASE. POLES MAY BE CAMBERED TO FALL WITHIN THE DESIGN LIMIT.
- MAXIMUM DEFLECTION AT TOP OF THE STRUCTURE SHALL BE LIMITED TO 10% OF STRUCTURE HEIGHT UNDER ALL LOAD CASES WITH THE EXCEPTION TO THE 60° NO WIND LOAD CASE.
- POLE DESIGN AND FABRICATION SHALL INCLUDE PROVISIONS FOR A SLIP JOINT TO LIMIT LOWEST POLE SEGMENT EXTENSION ABOVE GRADE TO 12'-0" MAXIMUM.
- ALL STRUCTURES SHALL BE GALVANIZED STEEL.
- ORIENT SINGLE SIDED VANGS FOR HARDWARE SHOWN ON DRAWINGS.
- MANUFACTURER SHALL APPLY POINT LOADS NECESSARY TO CREATE THE MOST SEVERE EFFECTS ON ALL MEMBERS INCLUDING ARMS, POLES, BASE PLATES, ETC.

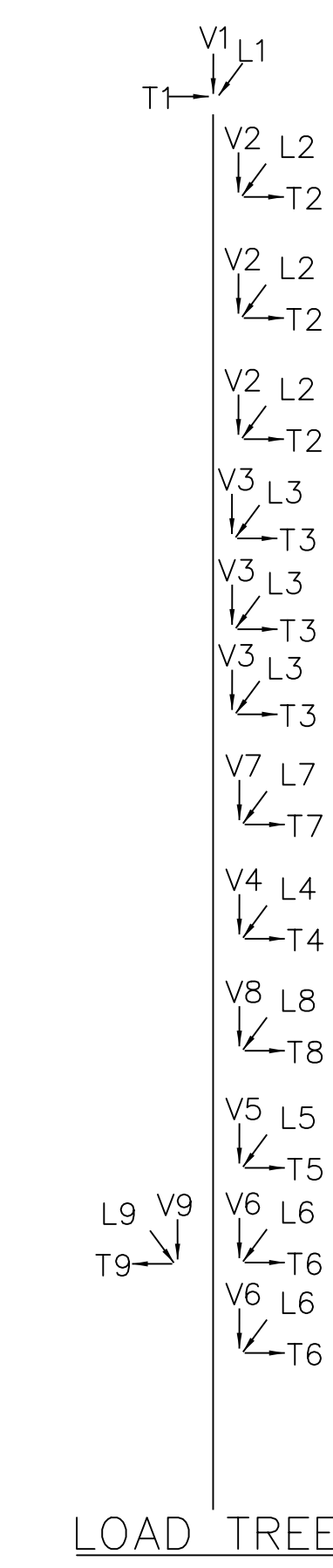

NO.	REVISIONS
A	MT. PLEASANT TO SUGG T-LINE ISSUED FOR BID ENGINEER'S: S.E DATE: 12/03/21

CONSTRUCTION NOTE:
REMOVE OLD WIRE LABELS WITH ORANGE TEXT,
INSTALL NEW WIRE LABELS WITH GREEN TEXT

ISSUED FOR BID

GREENVILLE UTILITIES
Greenville, North Carolina

115KV TRANSMISSION LINE
MT. PLEASANT SUB TO SUGG
LOAD AND DESIGN
DEADEND 60°-90° WITH UNDERBUILD

DWIND. CHAMBLISS DATE 12/03/21 DWG. NO.
CKD. R. DILLABOUGH APPD. S. ECKMAN DE-90R_STR-153
SCALE: NONE

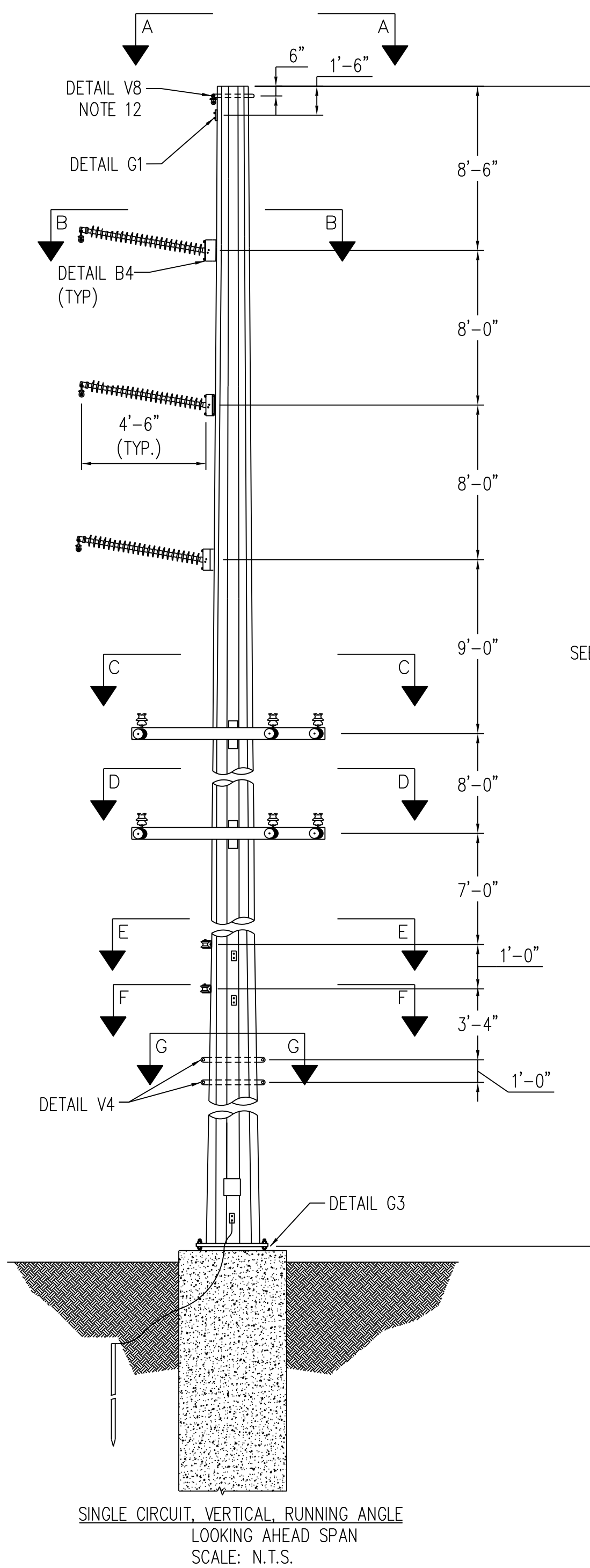

STR #	LENGTH (FT)	ANGLE Δ
3	85	-12

LOAD	LOADING TABLE				
	CASE 1	CASE 2	CASE 3	CASE 7	CASE 9
V1	300	100	600	100	700
T1	-1000	-800	-1200	-200	-1000
L1	100	100	100	-	-300
V2	900	500	1400	500	1500
T2	-3700	-3000	-2900	-600	-2600
L2	100	100	100	-100	-200
V3	600	300	1000	300	1100
T3	-3700	-5500	-2700	-500	-2100
L3	100	100	100	-100	-1100
V4	400	200	800	200	900
T4	-1900	-1500	-1700	-300	-1400
L4	100	100	100	-	-900
V5	300	200	800	100	900
T5	-800	-1000	-800	-200	-600
L5	100	100	100	-	-500
V6	500	200	1000	200	1100
T6	-800	-1300	-900	-100	-700
L6	100	100	100	-	-400
W(PSF)	10	36.9	4.1	0	0

LOAD CASES

- CASE 1 NESC MEDIUM: 15°, .25" ICE, 4 PSF WIND
OLF: L=1.65, T=2.50, V=1.50
- CASE 2 NESC HIGH WIND: 60°, 0" ICE, 120 MPH WIND
OLF: L=1.00, T=1.00, V=1.00
- CASE 3 NESC ICE WITH WIND: 15°, 1" ICE, 40 MPH WIND
OLF: L=1.00, T=1.00, V=1.00
- CASE 7 DEFLECTION: 60 DEGREES, NO ICE, NO WIND, FINAL
OLF: L=1.00, T=1.00, V=1.00
- CASE 9 UNBALANCED ICE: 32 DEGREES, 1" ICE, NO WIND
OLF: L=1.10, T=1.10, V=1.10

WIRE DATA

OHGW: "7#9" ALUMOWELD
 115kV: 1272 KCMIL 61/0 STRAND "NARCISSUS" AAC
 12.47kV: 795 KCMIL 37/0 STRAND "ARBUTUS" AAC
 DISTRIBUTION NEUTRAL: 336.4 KCMIL 18/1 STRAND "MERLIN" ACSR
 ADSS: "AT-XXX27DT-144-CLCB" 144 FIBER

NOTES:

- ALL STATED LOADS ARE ULTIMATE VALUES AND INCLUDE OVERLOAD FACTORS AND INSULATOR WEIGHT.
- STRUCTURE AND ATTACHMENTS SHALL BE DESIGNED FOR THE SIMULTANEOUS APPLICATION OF DEAD LOAD, WIND ON THE STRUCTURE, AND WIRE LOADS FOR EACH LOADING CASE.
- STRUCTURE SHALL BE DESIGNED SELF SUPPORTING, GUYS ARE NOT PERMITTED. STRUCTURE SHALL MEET ALL TECHNICAL REQUIREMENTS OF THE STEEL POLE SPECIFICATIONS.
- WIND PRESSURES SHOWN ON LOAD WORKSHEET ARE BASED ON A SHAPE FACTOR OF 1.0.
- FABRICATOR MAY PROPOSE STRUCTURAL DETAILS DIFFERENT THAN THOSE SHOWN TO SIMPLIFY FABRICATION. VARIATIONS SHALL BE SUBMITTED TO ENGINEER IN WRITING.
- MINIMUM VANG PLATE THICKNESS = 1/2".
- WIND SHALL BE APPLIED IN THE DIRECTION WHICH RESULTS IN THE MOST SEVERE EFFECT.
- THE DEFLECTION AT THE POLE TOP SHALL BE LIMITED TO 1.5% OF THE POLE HEIGHT UNDER THE DEFLECTION CASE. POLES MAY BE CAMBERED TO FALL WITHIN THE DESIGN LIMIT.
- MAXIMUM DEFLECTION AT TOP OF THE STRUCTURE SHALL BE LIMITED TO 10% OF STRUCTURE HEIGHT UNDER ALL LOAD CASES WITH THE EXCEPTION TO THE 60°F NO WIND LOAD CASE.
- POLE DESIGN AND FABRICATION SHALL INCLUDE PROVISIONS FOR A SLIP JOINT TO LIMIT LOWEST POLE SEGMENT EXTENSION ABOVE GRADE TO 12'-0" MAXIMUM.
- ALL STRUCTURES SHALL BE GALVANIZED STEEL.
- ORIENT SINGLE SIDED VANGS FOR HARDWARE SHOWN ON DRAWINGS.
- MANUFACTURER SHALL APPLY POINT LOADS NECESSARY TO CREATE THE MOST SEVERE EFFECTS ON ALL MEMBERS INCLUDING ARMS, POLES, BASE PLATES, ETC.

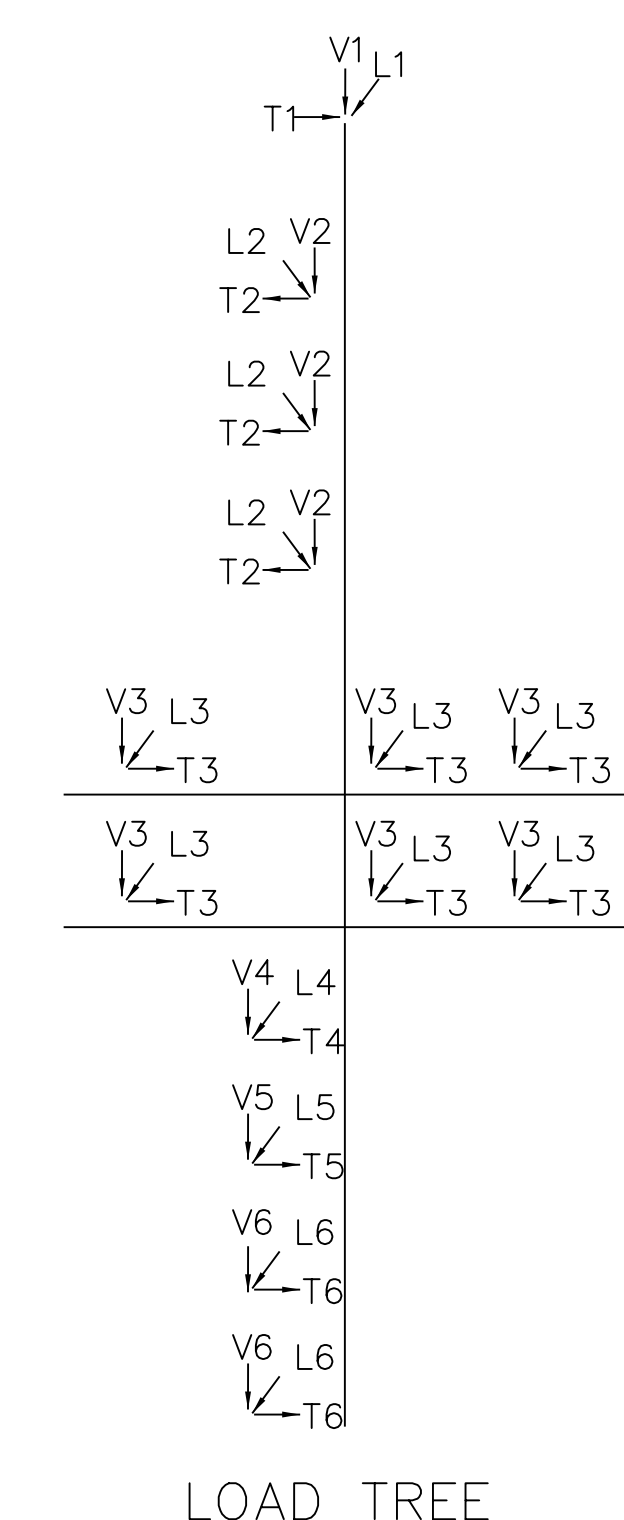
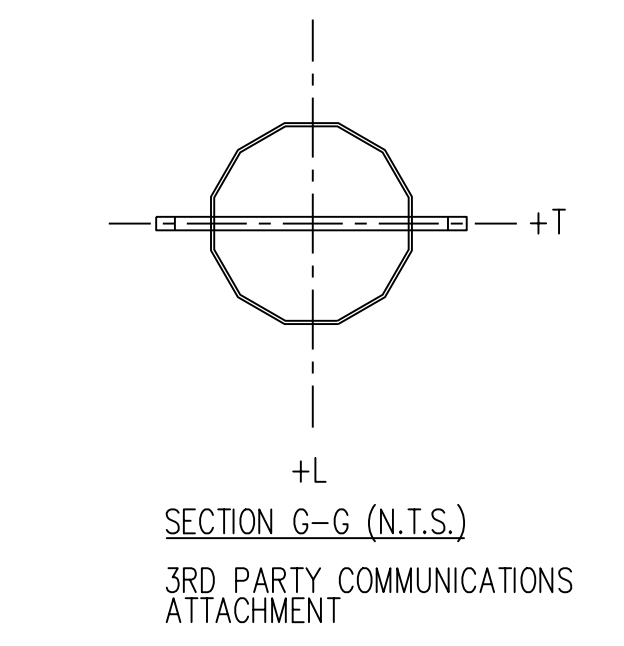
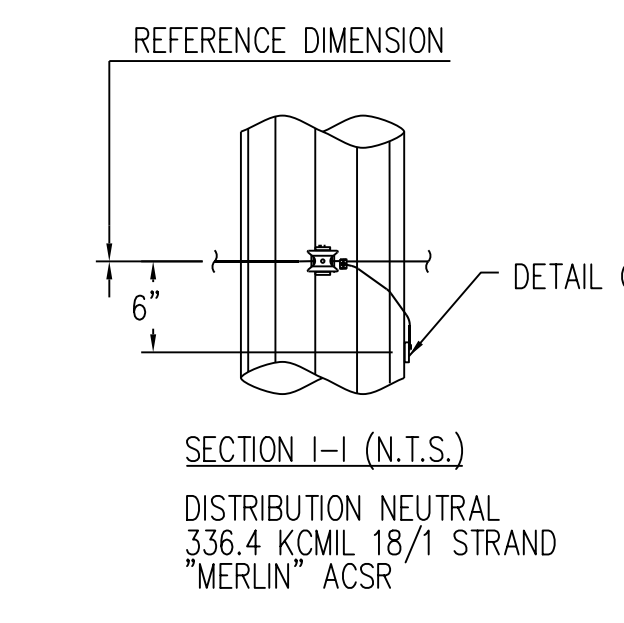
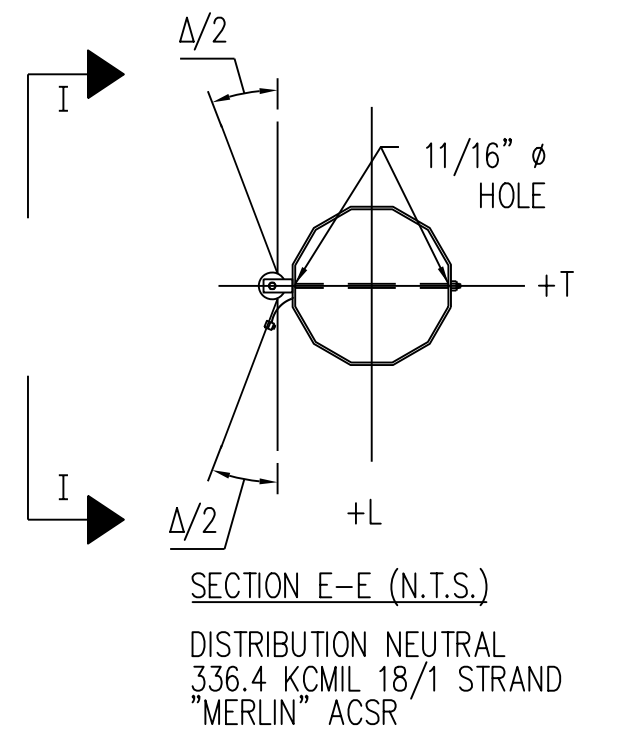
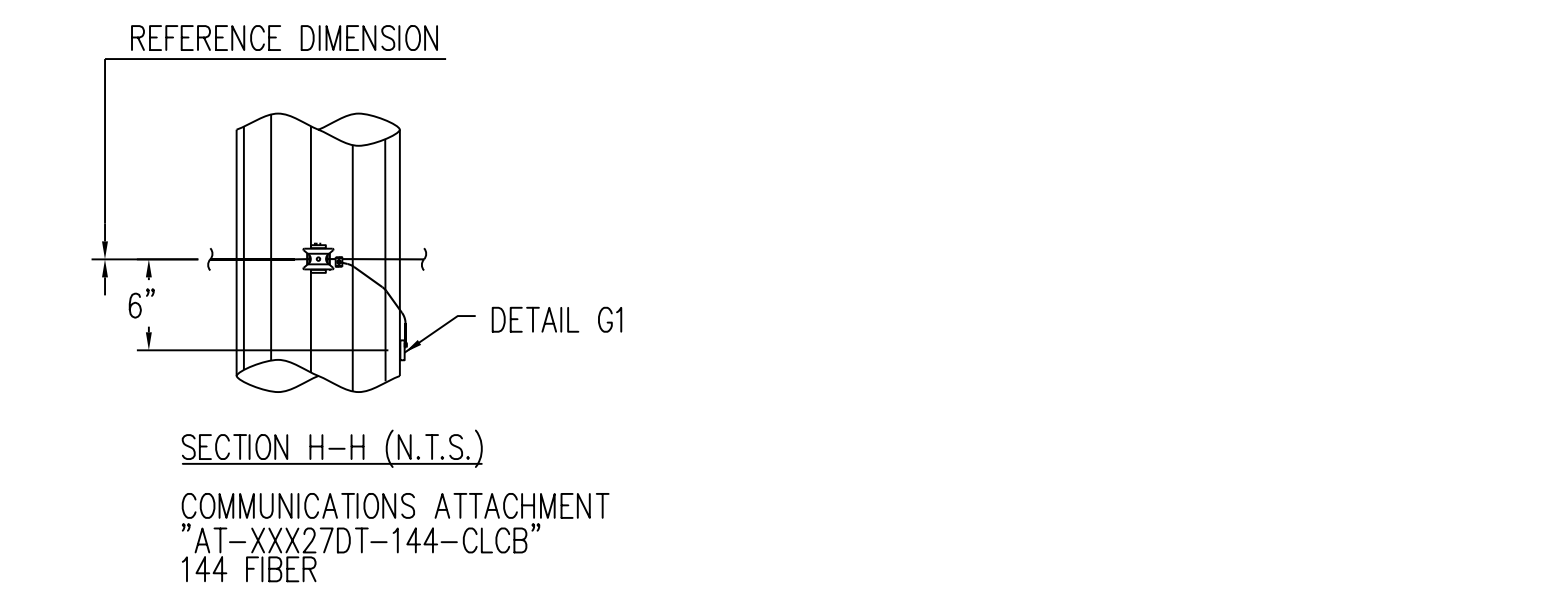
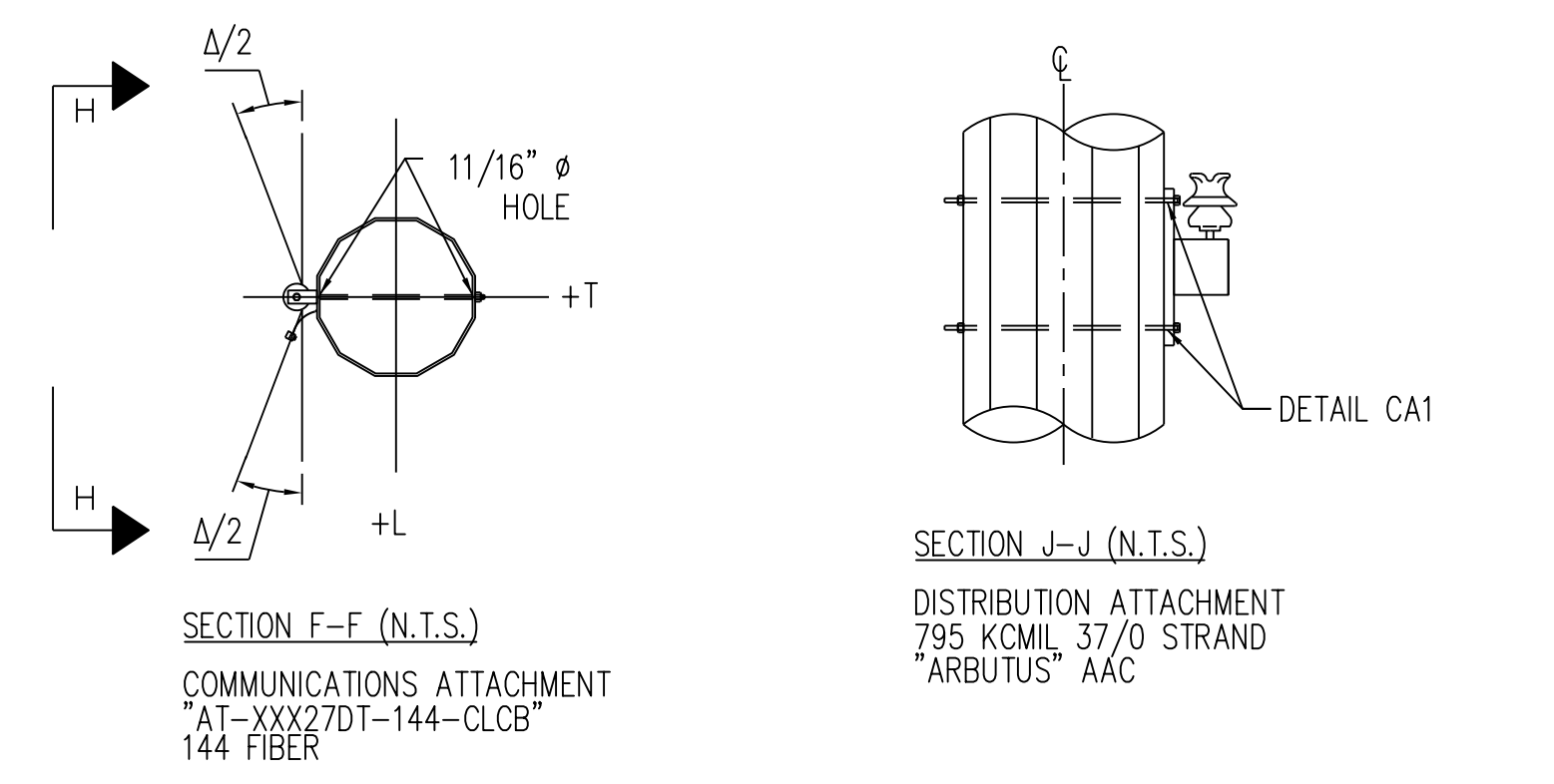
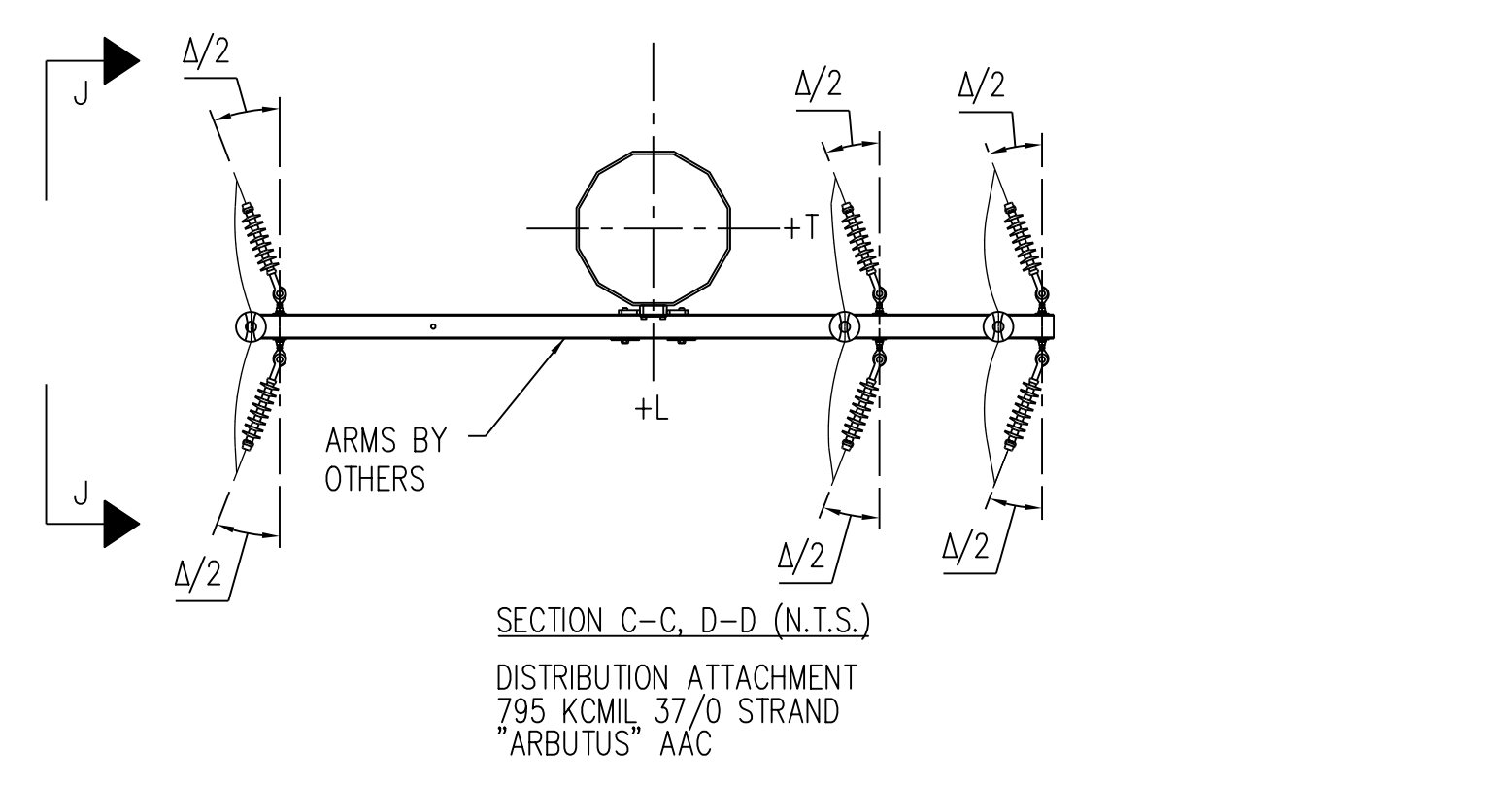
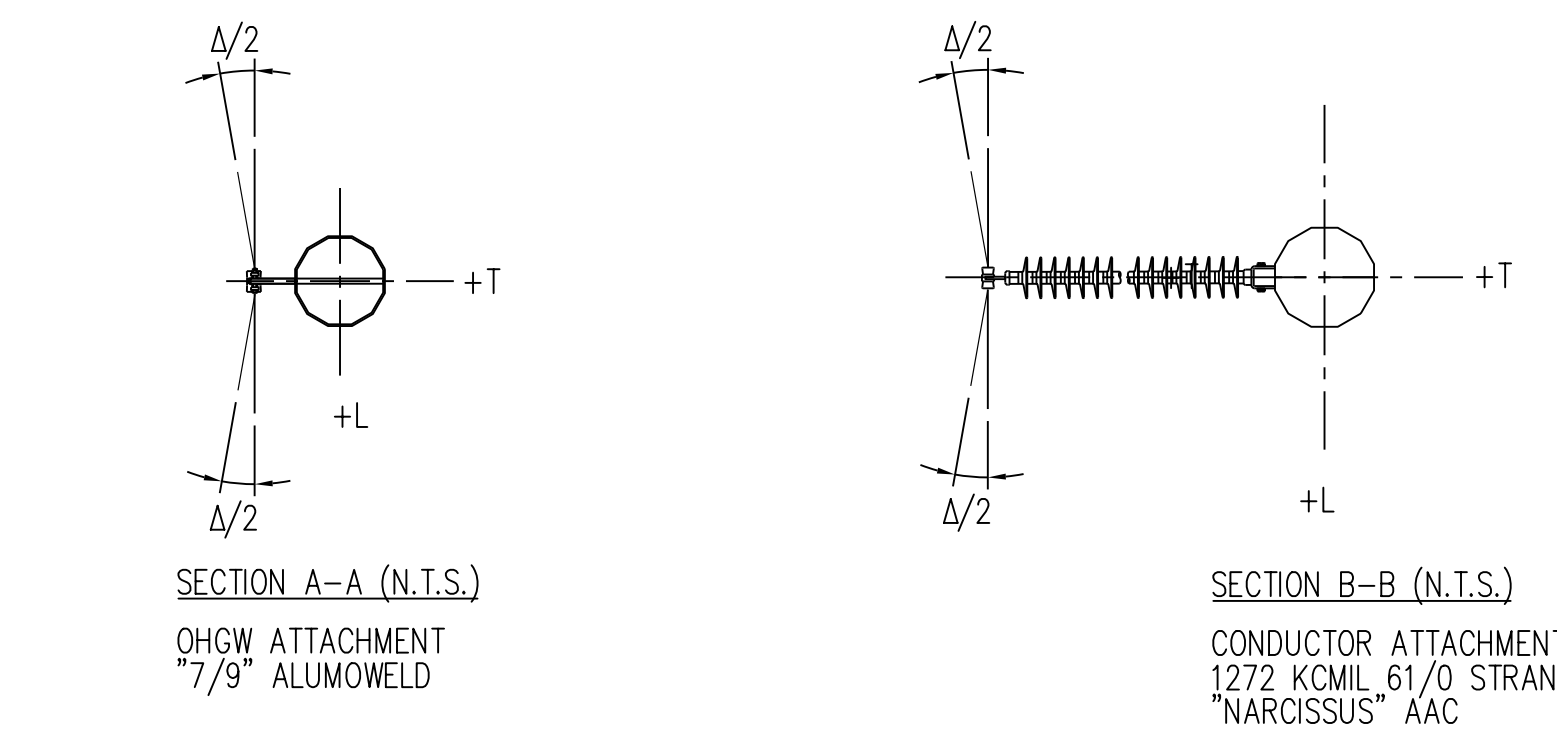

NO.	REVISIONS
A	MT. PLEASANT TO SUGG T-LINE ISSUED FOR BID ENGINEERS: S.E DATE: 12/03/21

CONSTRUCTION NOTE:
 REMOVE OLD WIRE LABELS WITH ORANGE TEXT,
 INSTALL NEW WIRE LABELS WITH GREEN TEXT

ISSUED FOR BID

GREENVILLE UTILITIES
 Greenville, North Carolina

115kV TRANSMISSION LINE
 MT. PLEASANT SUB TO SUGG
 LOAD AND DESIGN
 RUNNING ANGLE WITH UNDERBUILD

DWN.D. CHAMBLISS DATE 12/03/21 DWG. NO.
 CKD. R. DILLABOUGH APPD. S. ECKMAN RA-15L_2FFD_1-CT
 SCALE: NONE

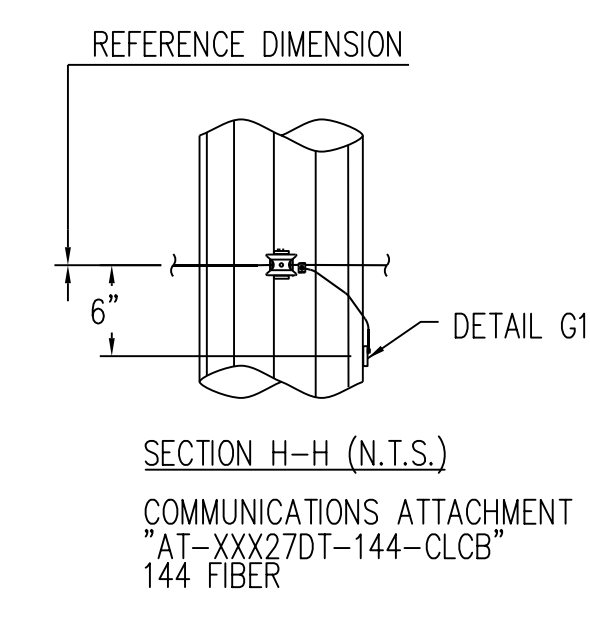
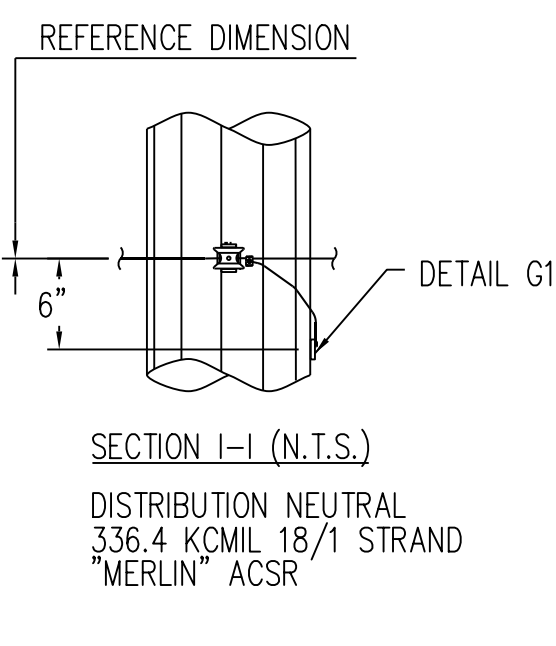
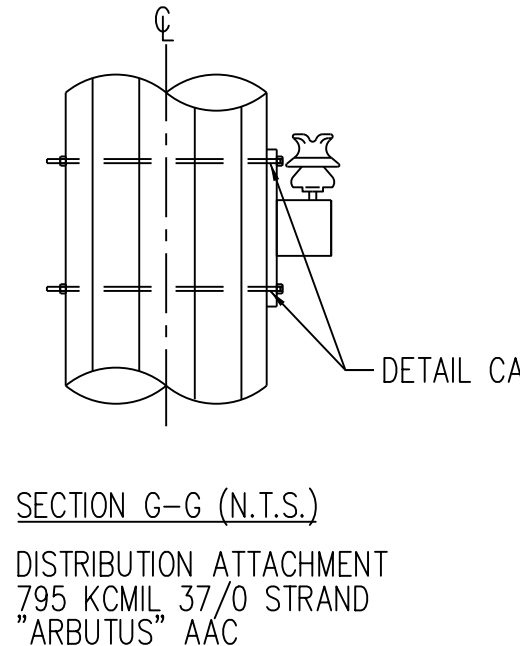
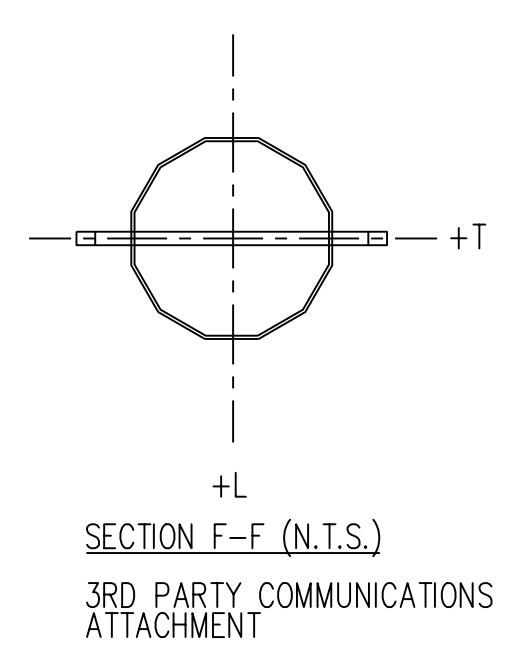
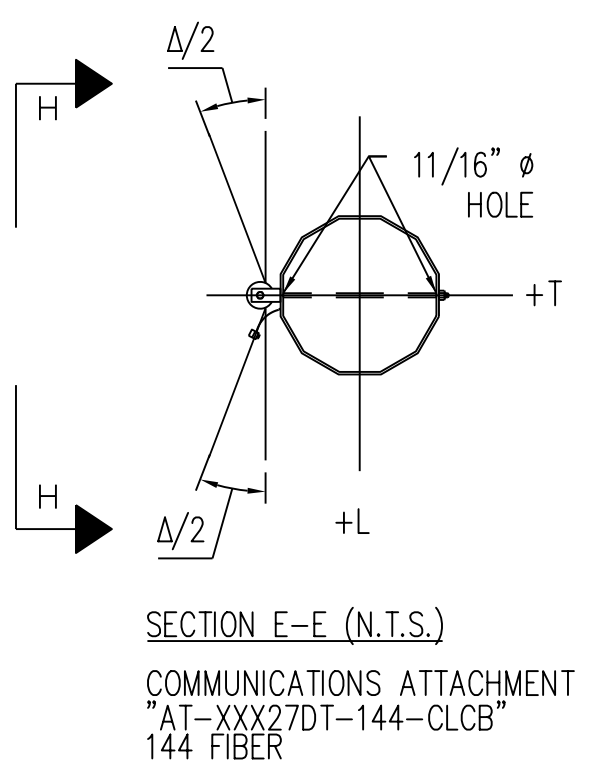
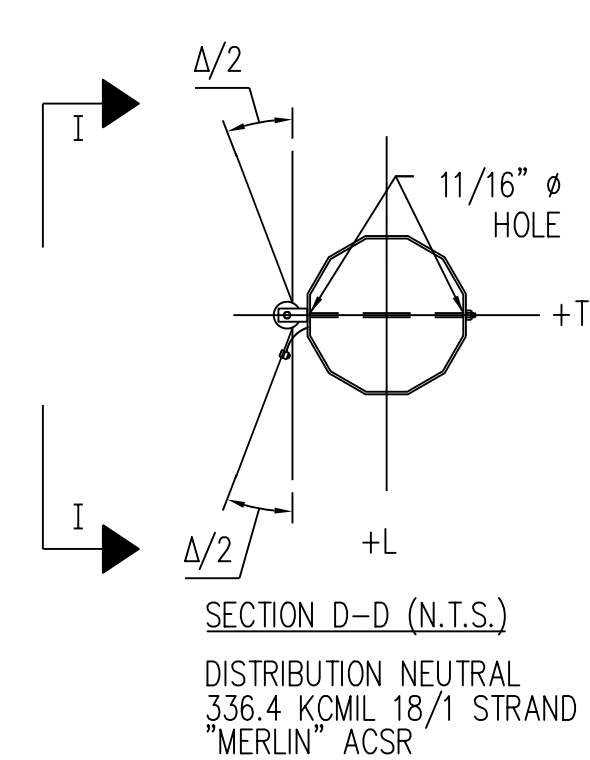
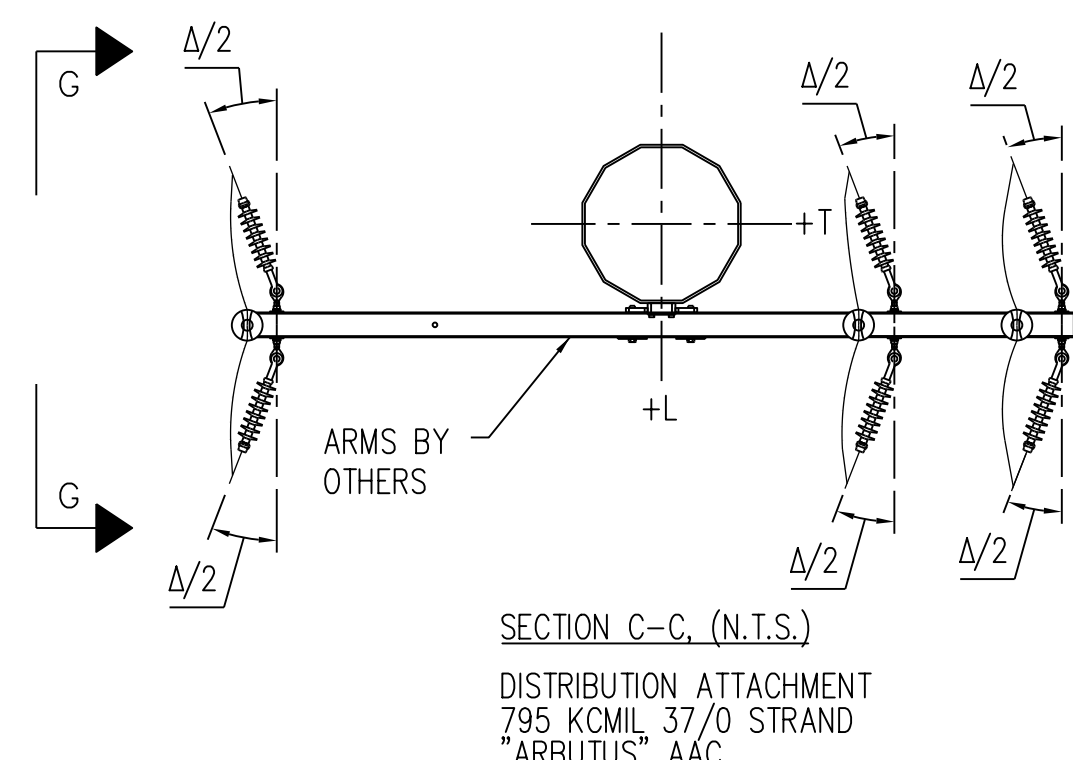
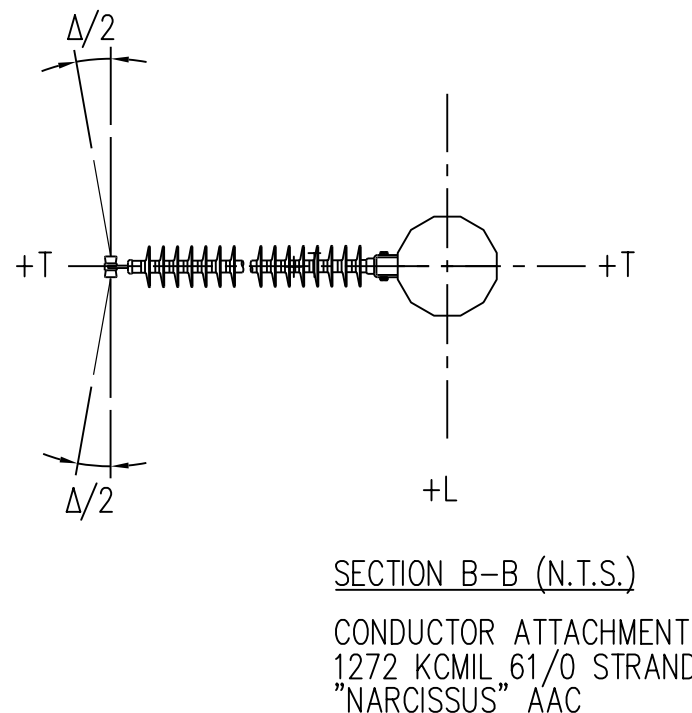
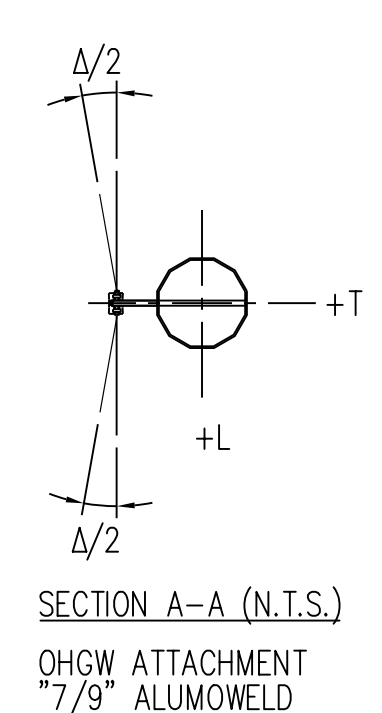
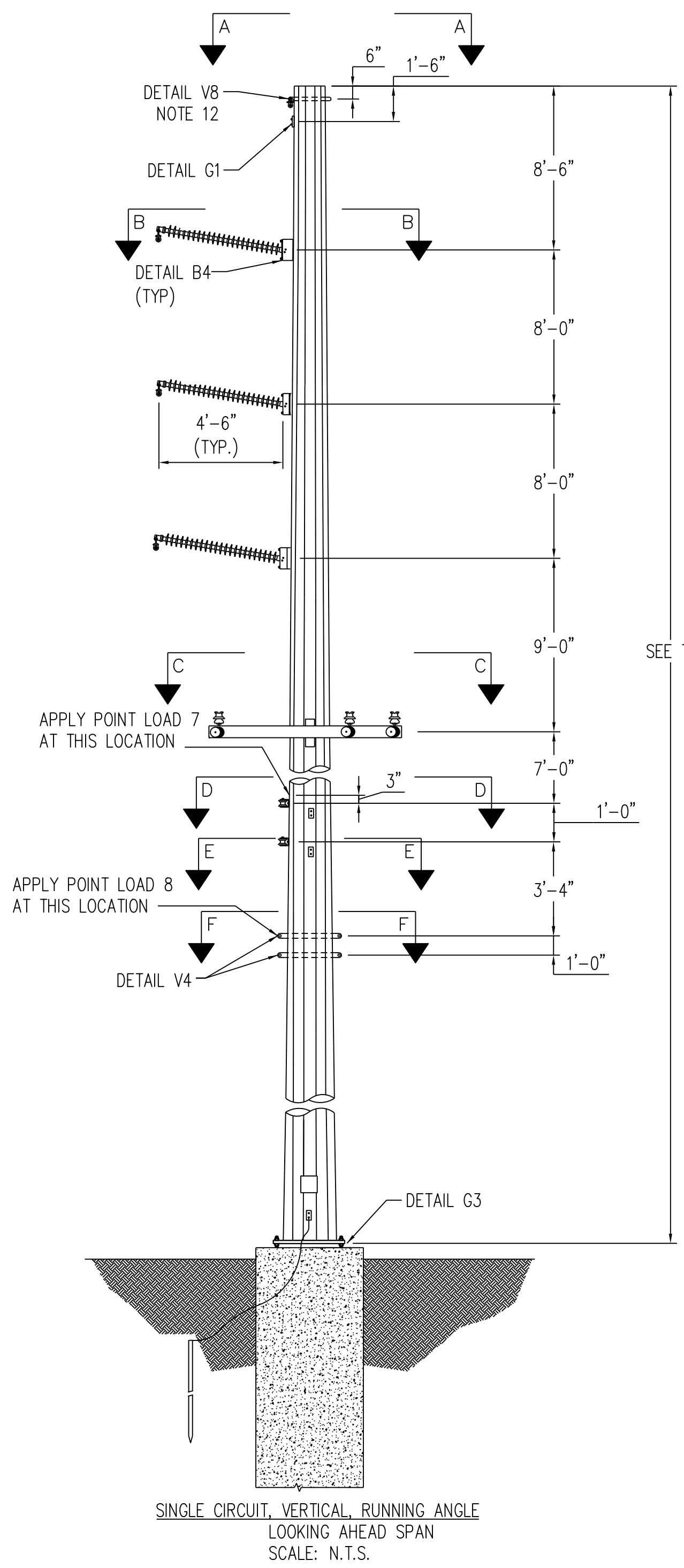

STR #	LENGTH (FT)	ANGLE Δ
18	80	-10
35	80	-4
40	75	-8
45	75	-15
46	80	-12
65*	75	-6
147*	75	-3

LOAD	LOADING TABLE				
	CASE 1	CASE 2	CASE 3	CASE 7	CASE 9
V1	300	100	600	100	700
T1	-1000	-800	-1200	-200	-1000
L1	-100	-100	-100	-	-300
V2	900	500	1400	500	1500
T2	-3700	-3000	-2900	-600	-2600
L2	-100	-100	-100	-100	-200
V3	600	300	1000	300	1100
T3	-3700	-5500	-2700	-500	-2100
L3	-100	-100	-100	-100	-1100
V4	400	200	800	200	900
T4	-1900	-1500	-1700	-300	-1400
L4	-100	-100	-100	-	-900
V5	300	200	800	100	900
T5	-800	-1000	-800	-200	-600
L5	-100	-100	-100	-	-500
V6	500	200	1000	200	1100
T6	-800	-1300	-900	-100	-700
L6	-100	-100	-100	-	-400
V7	800	300	1800	300	300
T7	-800	-1400	-1100	-100	-800
L7	-100	-200	-200	-100	-200
V8	900	300	2000	300	300
T8	-1900	-2500	-2100	-400	-1700
L8	-300	-300	-400	-100	-300
W(PSF)	10	36.9	4.1	0	0

ALL LOADS ARE IN LBS, ARE ULTIMATE, AND INCLUDE ALL OVERLOAD FACTORS. "W" REPRESENTS WIND PRESSURE (psf) TO BE APPLIED TO STRUCTURE.

* APPLY POINT LOAD 7 AND 8 TO STRUCTURES 65 AND 147 ONLY.

LOAD CASES

- CASE 1 NESC MEDIUM: 15°, .25" ICE, 4 PSF WIND
OLF: L=1.65, T=2.50, V=1.50
- CASE 2 NESC HIGH WIND: 60°, 0" ICE, 120 MPH WIND
OLF: L=1.00, T=1.00, V=1.00
- CASE 3 NESC ICE WITH WIND: 15°, 1" ICE, 40 MPH WIND
OLF: L=1.00, T=1.00, V=1.00
- CASE 7 DEFLECTION: 60 DEGREES, NO ICE, NO WIND, FINAL
OLF: L=1.00, T=1.00, V=1.00
- CASE 9 UNBALANCED ICE: 32 DEGREES, 1" ICE, NO WIND
OLF: L=1.10, T=1.10, V=1.10

WIRE DATA

OHGW: "7#9" ALUMOWELD
115KV: 1272 KCMIL 61/0 STRAND "NARCISSUS" AAC
12.47KV: 795 KCMIL 37/0 STRAND "ARBUTUS" AAC
DISTRIBUTION NEUTRAL: 336.4 KCMIL 18/1 STRAND "MERLIN" ACSR
ADSS: "AT-XXX27DT-144-CLCB" 144 FIBER

NOTES:

- ALL STATED LOADS ARE ULTIMATE VALUES AND INCLUDE OVERLOAD FACTORS AND INSULATOR WEIGHT.
- STRUCTURE AND ATTACHMENTS SHALL BE DESIGNED FOR THE SIMULTANEOUS APPLICATION OF DEAD LOAD, WIND ON THE STRUCTURE, AND WIRE LOADS FOR EACH LOADING CASE.
- STRUCTURE SHALL BE DESIGNED SELF SUPPORTING, GUYS ARE NOT PERMITTED. STRUCTURE SHALL MEET ALL TECHNICAL REQUIREMENTS OF THE STEEL POLE SPECIFICATIONS.
- WIND PRESSURES SHOWN ON LOAD WORKSHEET ARE BASED ON A SHAPE FACTOR OF 1.0.
- FABRICATOR MAY PROPOSE STRUCTURAL DETAILS DIFFERENT THAN THOSE SHOWN TO SIMPLIFY FABRICATION. VARIATIONS SHALL BE SUBMITTED TO ENGINEER IN WRITING.
- MINIMUM VANG PLATE THICKNESS = 1/2".
- WIND SHALL BE APPLIED IN THE DIRECTION WHICH RESULTS IN THE MOST SEVERE EFFECT.
- THE DEFLECTION AT THE POLE TOP SHALL BE LIMITED TO 1.5% OF THE POLE HEIGHT UNDER THE DEFLECTION CASE. POLES MAY BE CAMBERED TO FALL WITHIN THE DESIGN LIMIT.
- MAXIMUM DEFLECTION AT TOP OF THE STRUCTURE SHALL BE LIMITED TO 10% OF STRUCTURE HEIGHT UNDER ALL LOAD CASES WITH THE EXCEPTION TO THE 60° NO WIND LOAD CASE.
- POLE DESIGN AND FABRICATION SHALL INCLUDE PROVISIONS FOR A SLIP JOINT TO LIMIT LOWEST POLE SEGMENT EXTENSION ABOVE GRADE TO 12'-0" MAXIMUM.
- ALL STRUCTURES SHALL BE GALVANIZED STEEL.
- ORIENT SINGLE SIDED VANGS FOR HARDWARE SHOWN ON DRAWINGS.
- MANUFACTURER SHALL APPLY POINT LOADS NECESSARY TO CREATE THE MOST SEVERE EFFECTS ON ALL MEMBERS INCLUDING ARMS, POLES, BASE PLATES, ETC.

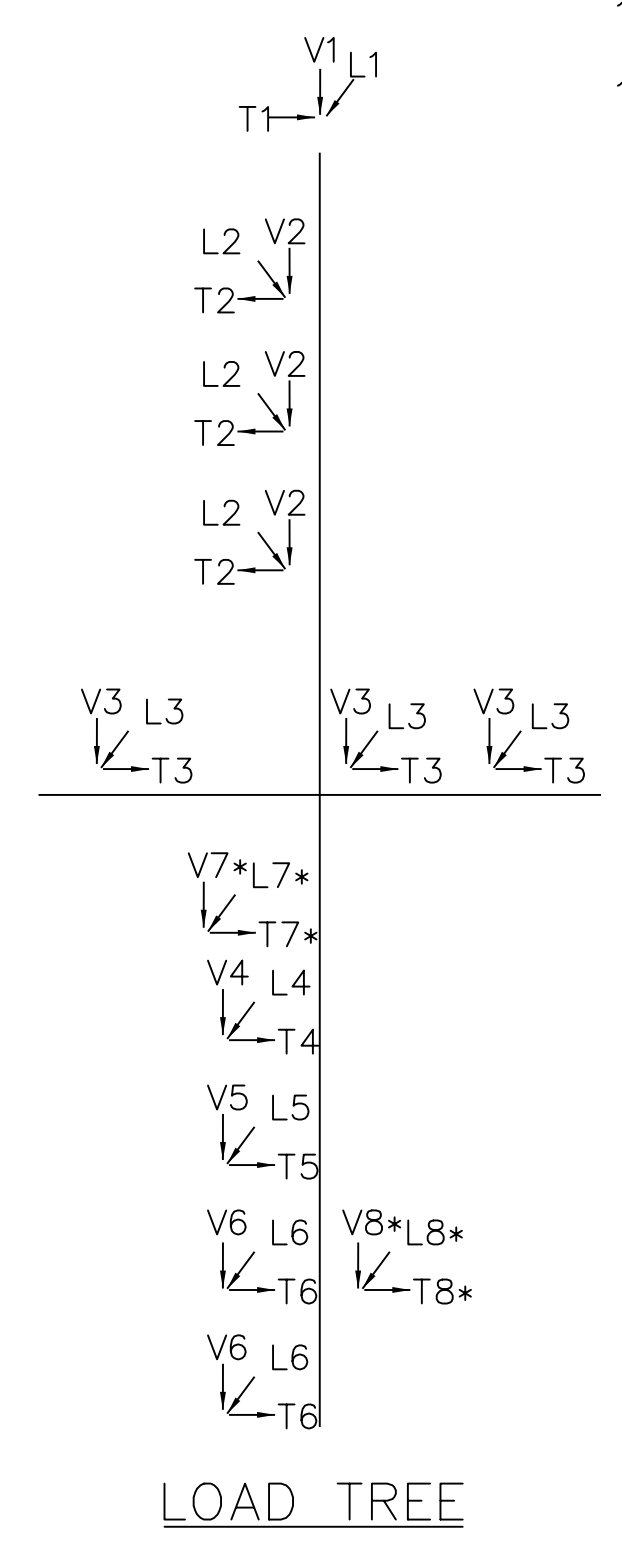

CONSTRUCTION NOTE:
REMOVE OLD WIRE LABELS WITH ORANGE TEXT,
INSTALL NEW WIRE LABELS WITH GREEN TEXT

ISSUED FOR BID

NO.	A
REVISIONS	MT. PLEASANT TO SUGG T-LINE ISSUED FOR BID ENGINEER'S: S.E DATE: 12/03/21

GREENVILLE UTILITIES
Greenville, North Carolina

115KV TRANSMISSION LINE
MT. PLEASANT SUB TO SUGG
LOAD AND DESIGN
RUNNING ANGLE WITH UNDERBUILD

DWIND. CHAMBLISS DATE 12/03/21
CKD. R. DILLABOUGH APPD. S. ECKMAN
SCALE: NONE

DWG. NO.
RA-15L_FFD_1-Ct

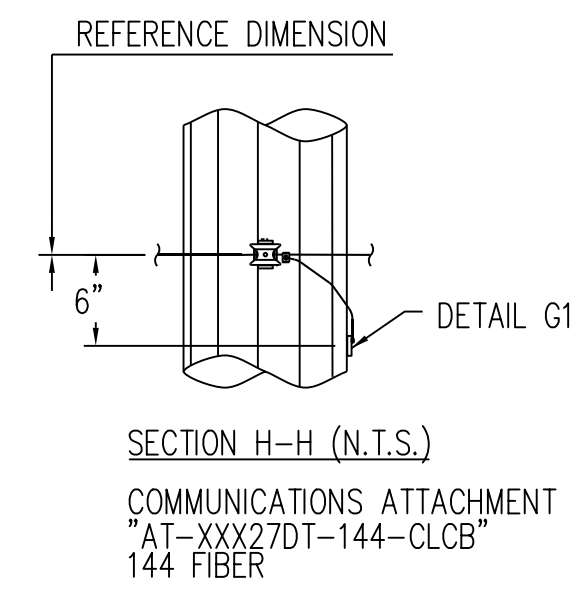
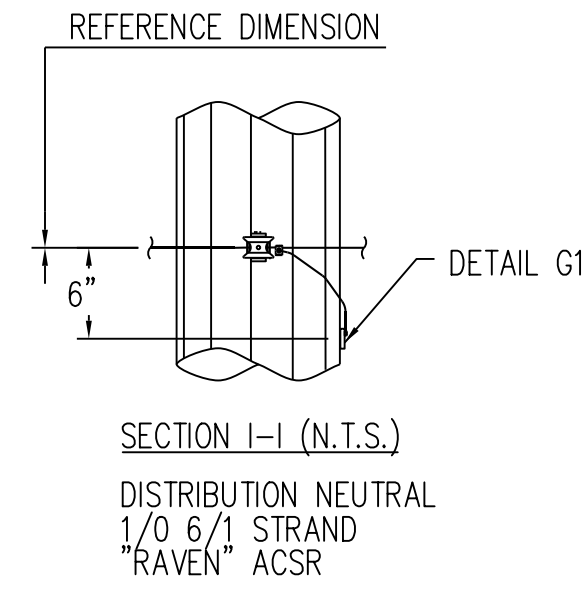
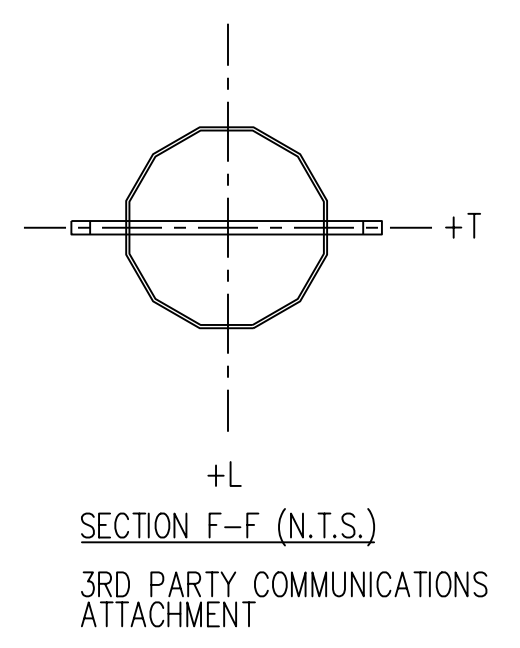
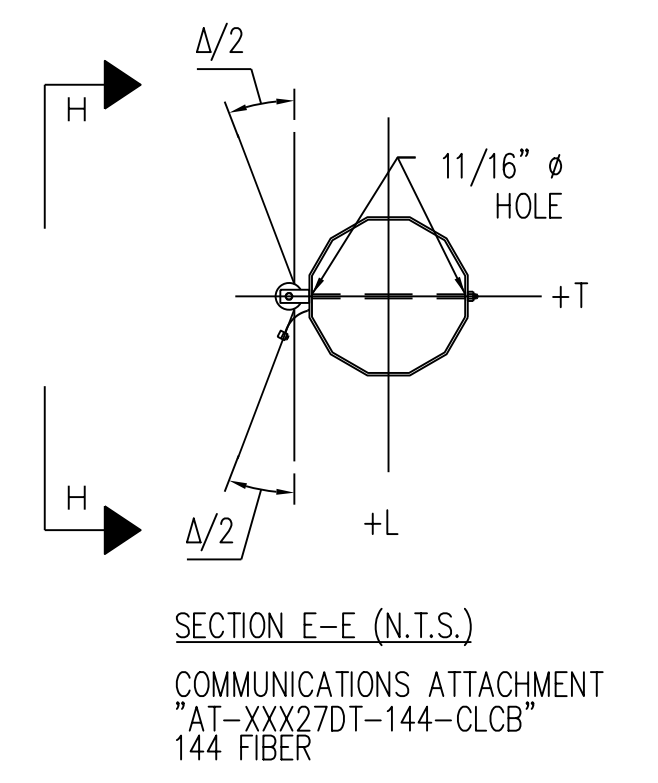
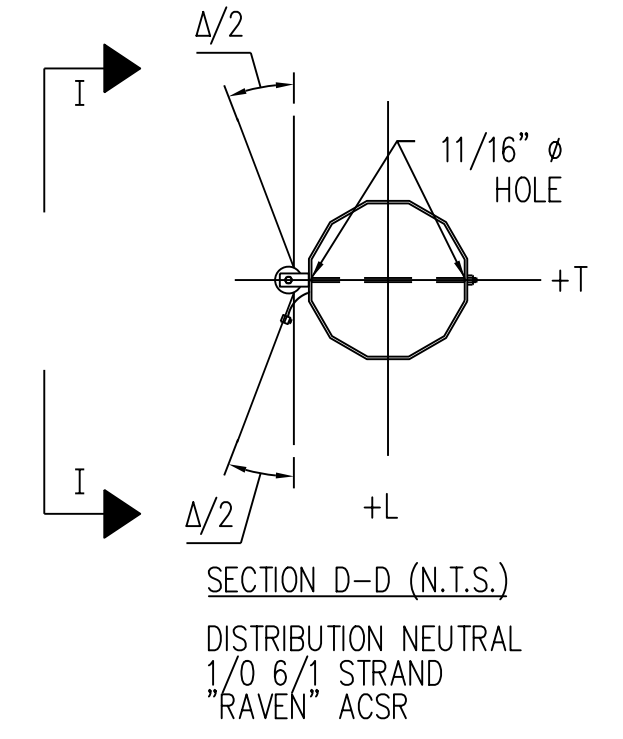
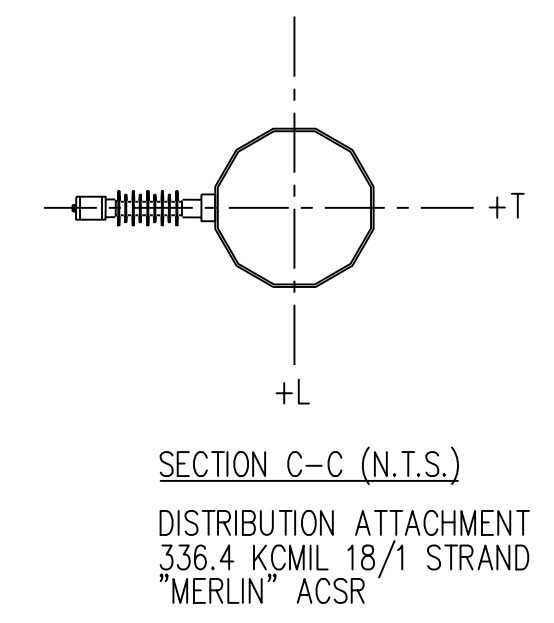
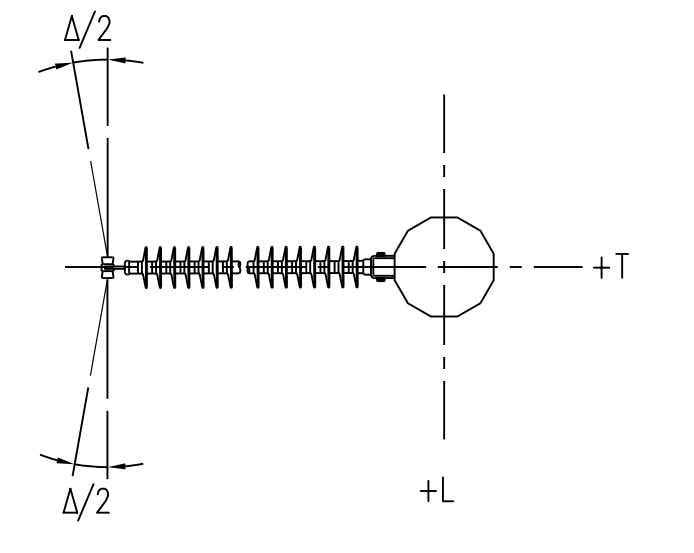
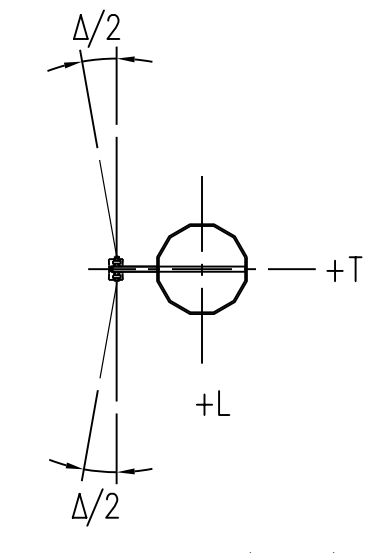
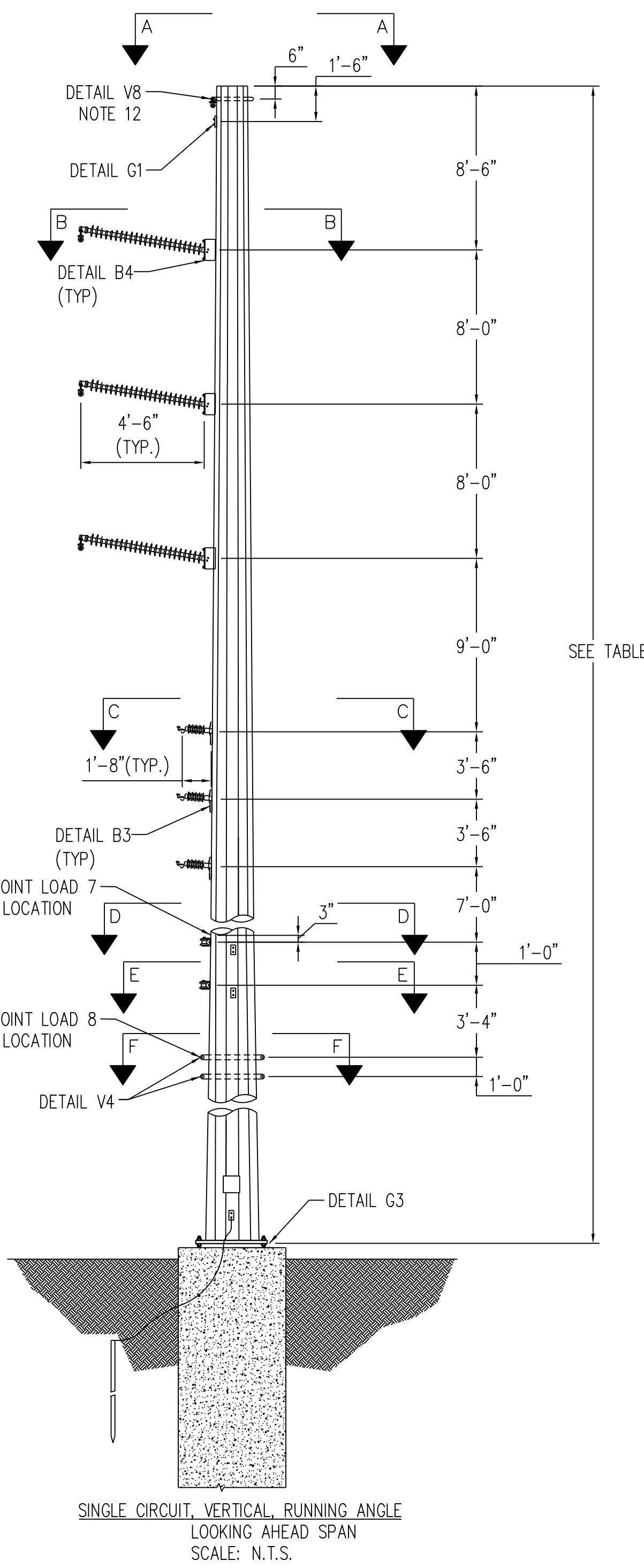

STR #	LENGTH (FT)	ANGLE Δ
114	90	-5
115	90	-5
140	80	-14
141*	80	-9

LOAD	LOADING TABLE				
	CASE 1	CASE 2	CASE 3	CASE 7	CASE 9
V1	300	100	600	100	700
T1	-1000	-800	-1200	-200	-1000
L1	-100	-100	-100	-	-300
V2	900	500	1400	500	1500
T2	-3700	-3000	-2900	-600	-2600
L2	-100	-100	-100	-100	-200
V3	600	300	1000	300	1100
T3	-3700	-5500	-2700	-500	-2100
L3	-100	-100	-100	-100	-1100
V4	400	200	800	200	900
T4	-1900	-1500	-1700	-300	-1400
L4	-100	-100	-100	-	-900
V5	300	200	800	100	900
T5	-800	-1000	-800	-200	-600
L5	-100	-100	-100	-	-500
V6	500	200	1000	200	1100
T6	-800	-1300	-900	-100	-700
L6	-100	-100	-100	-	-400
V7	600	200	1400	200	200
T7	-400	-800	-400	-100	-200
L7	-500	-700	-800	-100	-700
V8	700	300	1500	300	300
T8	-700	-1100	-600	-100	-300
L8	-1500	-1500	-1600	-500	-1500
W(psf)	10	36.9	4.1	0	0

ALL LOADS ARE IN LBS, ARE ULTIMATE, AND INCLUDE ALL OVERLOAD FACTORS. "W" REPRESENTS WIND PRESSURE (psf) TO BE APPLIED TO STRUCTURE.

* APPLY POINT LOAD 7 AND 8 TO STRUCTURE 141 ONLY.

LOAD CASES

- CASE 1 NESI MEDIUM: 15°, .25" ICE, 4 PSF WIND
OLF: L=1.65, T=2.50, V=1.50
- CASE 2 NESI HIGH WIND: 60°, 0" ICE, 120 MPH WIND
OLF: L=1.00, T=1.00, V=1.00
- CASE 3 NESI ICE WITH WIND: 15°, 1" ICE, 40 MPH WIND
OLF: L=1.00, T=1.00, V=1.00
- CASE 7 DEFLECTION: 60 DEGREES, NO ICE, NO WIND, FINAL
OLF: L=1.00, T=1.00, V=1.00
- CASE 9 UNBALANCED ICE: 32 DEGREES, 1" ICE, NO WIND
OLF: L=1.10, T=1.10, V=1.10

WIRE DATA

OHGW: "7#9" ALUMOWELD
115kV: 1272 KCMIL 61/0 STRAND "NARCISSUS" AAC
12.47kV: 336.4 KCMIL 18/1 STRAND "MERLIN" ACSR
DISTRIBUTION NEUTRAL: 1/0 6/1 STRAND "RAVEN" ACSR
ADSS: "AT-XXX27DT-144-CLCB" 144 FIBER

NOTES:

- ALL STATED LOADS ARE ULTIMATE VALUES AND INCLUDE OVERLOAD FACTORS AND INSULATOR WEIGHT.
- STRUCTURE AND ATTACHMENTS SHALL BE DESIGNED FOR THE SIMULTANEOUS APPLICATION OF DEAD LOAD, WIND ON THE STRUCTURE, AND WIRE LOADS FOR EACH LOADING CASE.
- STRUCTURE SHALL BE DESIGNED SELF SUPPORTING, GUYS ARE NOT PERMITTED. STRUCTURE SHALL MEET ALL TECHNICAL REQUIREMENTS OF THE STEEL POLE SPECIFICATIONS.
- WIND PRESSURES SHOWN ON LOAD WORKSHEET ARE BASED ON A SHAPE FACTOR OF 1.0.
- FABRICATOR MAY PROPOSE STRUCTURAL DETAILS DIFFERENT THAN THOSE SHOWN TO SIMPLIFY FABRICATION. VARIATIONS SHALL BE SUBMITTED TO ENGINEER IN WRITING.
- MINIMUM VANG PLATE THICKNESS = 1/2".
- WIND SHALL BE APPLIED IN THE DIRECTION WHICH RESULTS IN THE MOST SEVERE EFFECT.
- THE DEFLECTION AT THE POLE TOP SHALL BE LIMITED TO 1.5% OF THE POLE HEIGHT UNDER THE DEFLECTION CASE. POLES MAY BE CAMBERED TO FALL WITHIN THE DESIGN LIMIT.
- MAXIMUM DEFLECTION AT TOP OF THE STRUCTURE SHALL BE LIMITED TO 10% OF STRUCTURE HEIGHT UNDER ALL LOAD CASES WITH THE EXCEPTION TO THE 60°F NO WIND LOAD CASE.
- POLE DESIGN AND FABRICATION SHALL INCLUDE PROVISIONS FOR A SLIP JOINT TO LIMIT LOWEST POLE SEGMENT EXTENSION ABOVE GRADE TO 12'-0" MAXIMUM.
- ALL STRUCTURES SHALL BE GALVANIZED STEEL.
- ORIENT SINGLE SIDED VANGS FOR HARDWARE SHOWN ON DRAWINGS.
- MANUFACTURER SHALL APPLY POINT LOADS NECESSARY TO CREATE THE MOST SEVERE EFFECTS ON ALL MEMBERS INCLUDING ARMS, POLES, BASE PLATES, ETC.

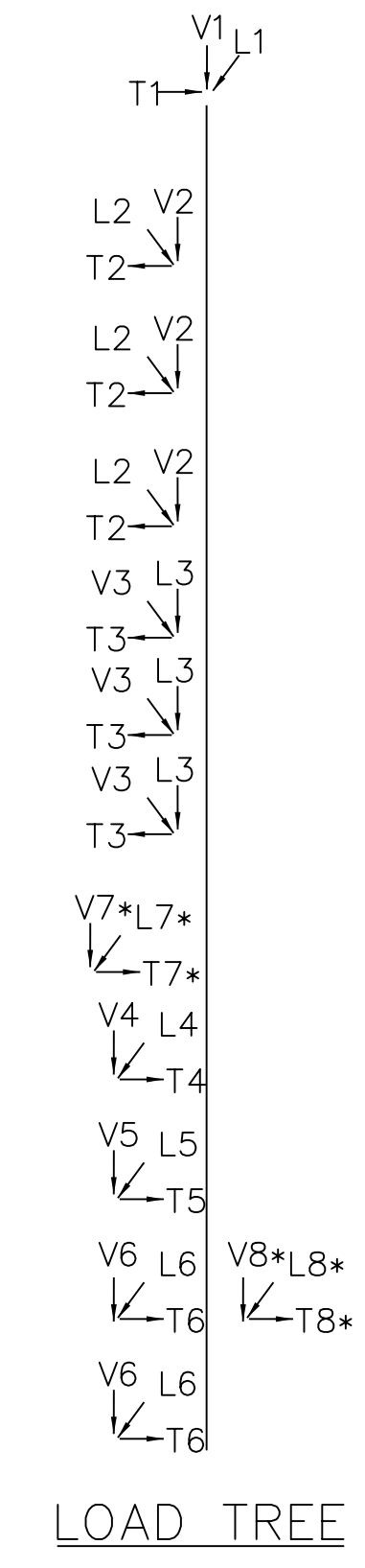

NO.	REVISIONS
A	MT. PLEASANT TO SUGG T-LINE ISSUED FOR BID ENGINEERS: S.E DATE: 12/03/21

CONSTRUCTION NOTE:
REMOVE OLD WIRE LABELS WITH ORANGE TEXT,
INSTALL NEW WIRE LABELS WITH GREEN TEXT

ISSUED FOR BID

GREENVILLE UTILITIES
Greenville, North Carolina

115kV TRANSMISSION LINE
MT. PLEASANT SUB TO SUGG
LOAD AND DESIGN
RUNNING ANGLE WITH UNDERBUILD

DWIND, CHAMBLISS DATE 12/03/21 DWG. NO.
CKD, R. DILLABOUGH APPD. S. ECKMAN RA-15L_VERT_1-CT
SCALE: NONE

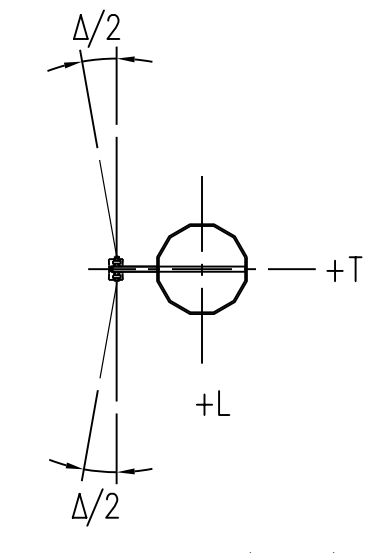
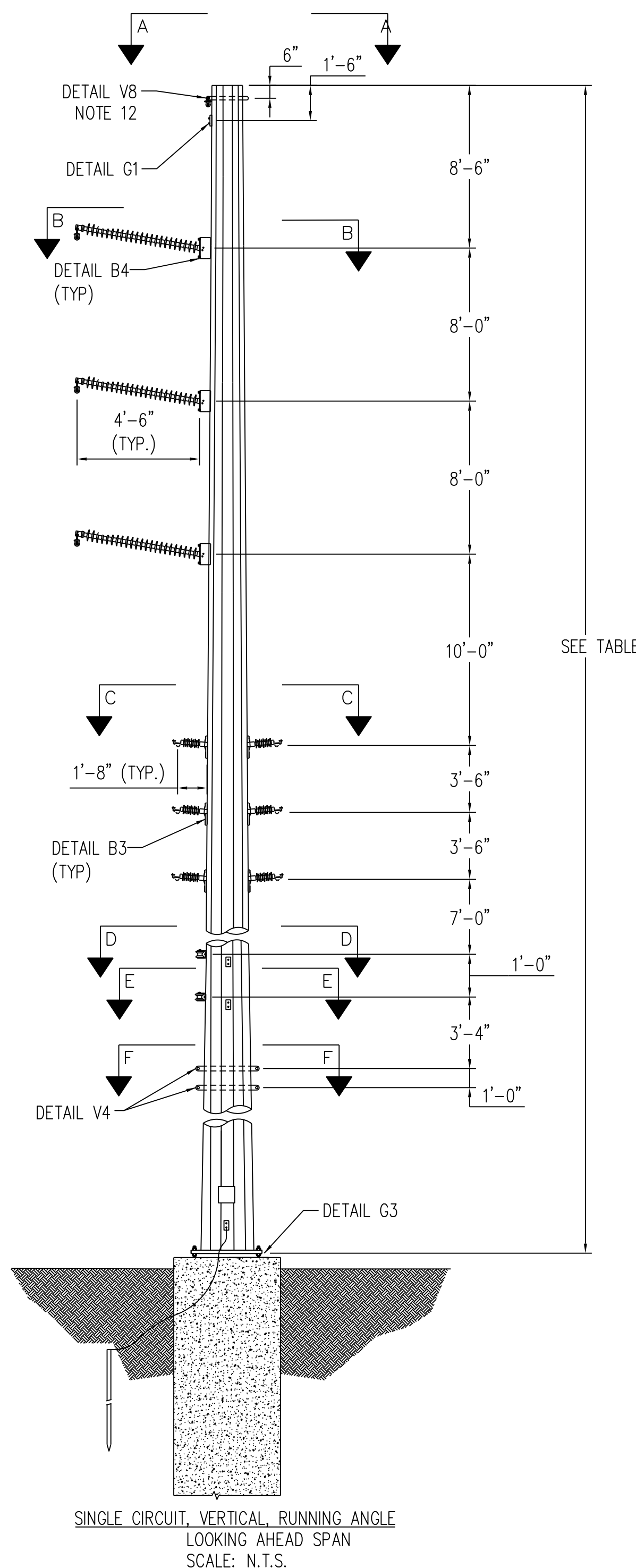

SECTION A-A (N.T.S.)
OHGW ATTACHMENT
"7/9" ALUMOWELD

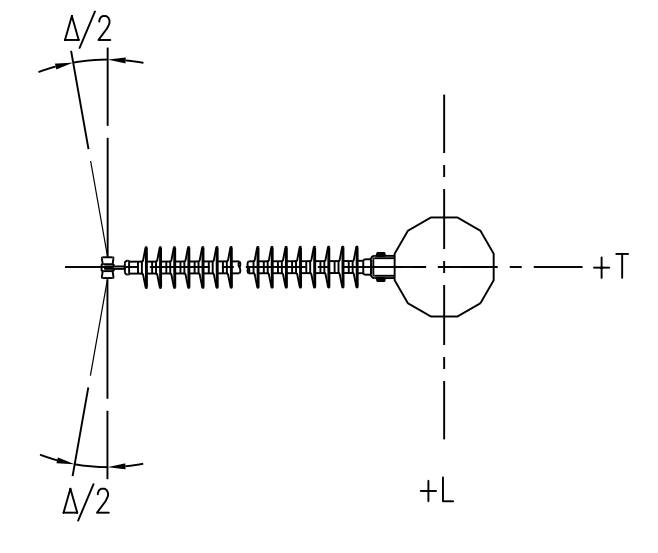

SECTION B-B (N.T.S.)
CONDUCTOR ATTACHMENT
1272 KCMIL 61/0 STRAND
"NARCISSUS" AAC

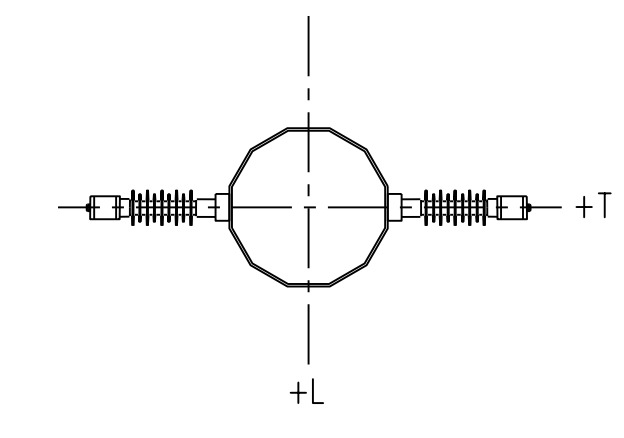

SECTION C-C (N.T.S.)
DISTRIBUTION ATTACHMENT
336.4 KCMIL 18/1 STRAND
"MERLIN" ACSR

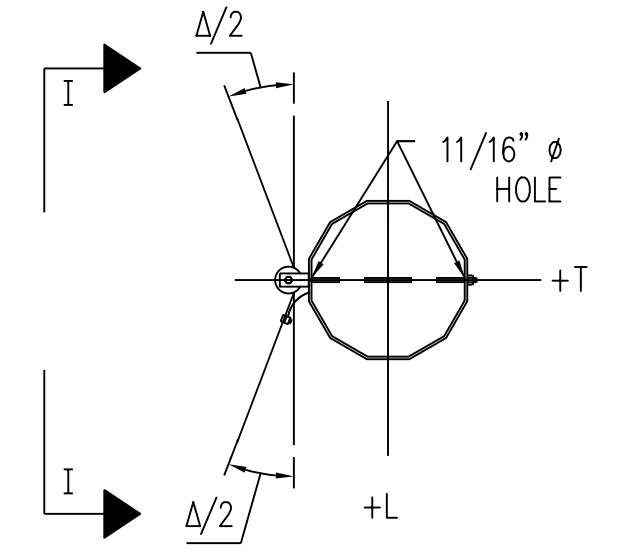

SECTION D-D (N.T.S.)
DISTRIBUTION NEUTRAL
336.4 KCMIL 18/1 STRAND
"MERLIN" ACSR

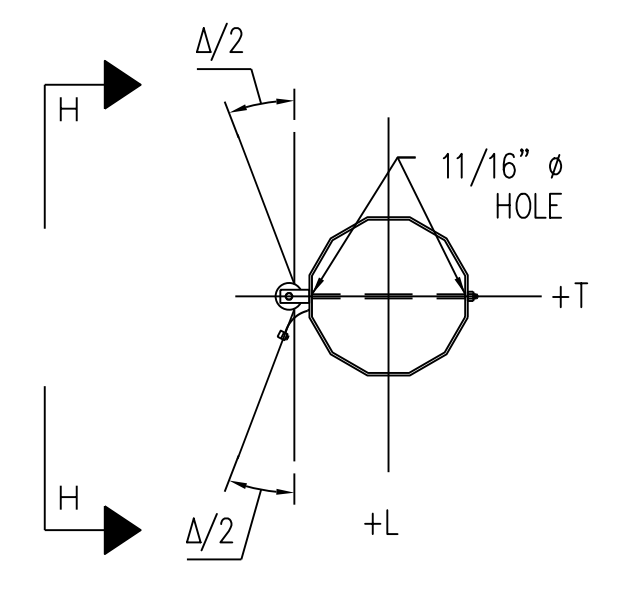

SECTION E-E (N.T.S.)
COMMUNICATIONS ATTACHMENT
"AT-XXX27DT-144-CLCB"
144 FIBER

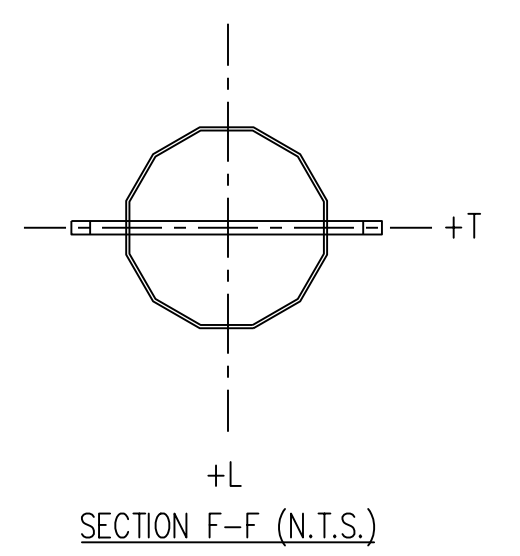

SECTION F-F (N.T.S.)
3RD PARTY COMMUNICATIONS
ATTACHMENT

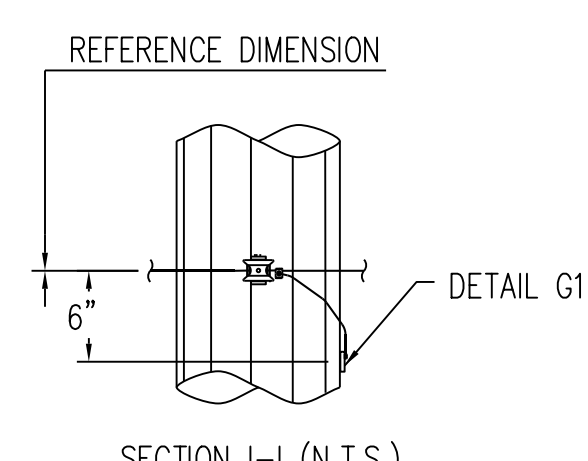

SECTION I-I (N.T.S.)
DISTRIBUTION NEUTRAL
336.4 KCMIL 18/1 STRAND
"MERLIN" ACSR

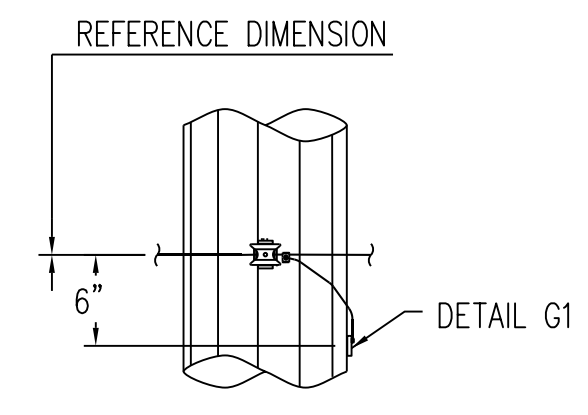

SECTION H-H (N.T.S.)
COMMUNICATIONS ATTACHMENT
"AT-XXX27DT-144-CLCB"
144 FIBER

STR #	LENGTH (FT)	ANGLE Δ
61	90	-6

LOAD	LOADING TABLE				
	CASE 1	CASE 2	CASE 3	CASE 7	CASE 9
V1	300	100	600	100	700
T1	-1000	-800	-1200	-200	-1000
L1	100	100	100	-	-300
V2	900	500	1400	500	1500
T2	-3700	-3000	-2900	-600	-2600
L2	100	100	100	-100	-200
V3	600	300	1000	300	1100
T3	-3700	-5500	-2700	-500	-2100
L3	100	100	100	-100	-1100
V4	400	200	800	200	900
T4	-1900	-1500	-1700	-300	-1400
L4	100	100	100	-	-900
V5	300	200	800	100	900
T5	-800	-1000	-800	-200	-600
L5	100	100	100	-	-500
V6	500	200	1000	200	1100
T6	-800	-1300	-900	-100	-700
L6	100	100	100	-	-400
W(PSF)	10	36.9	4.1	0	0

ALL LOADS ARE IN LBS, ARE ULTIMATE, AND INCLUDE ALL OVERLOAD FACTORS. "W" REPRESENTS WIND PRESSURE (psf) TO BE APPLIED TO STRUCTURE.

LOAD CASES

- CASE 1 NESC MEDIUM: 15°, .25" ICE, 4 PSF WIND
OLF: L=1.65, T=2.50, V=1.50
- CASE 2 NESC HIGH WIND: 60°, 0" ICE, 120 MPH WIND
OLF: L=1.00, T=1.00, V=1.00
- CASE 3 NESC ICE WITH WIND: 15°, 1" ICE, 40 MPH WIND
OLF: L=1.00, T=1.00, V=1.00
- CASE 7 DEFLECTION: 60 DEGREES, NO ICE, NO WIND, FINAL
OLF: L=1.00, T=1.00, V=1.00
- CASE 9 UNBALANCED ICE: 32 DEGREES, 1" ICE, NO WIND
OLF: L=1.10, T=1.10, V=1.10

WIRE DATA

OHGW: "7#9" ALUMOWELD
115kV: 1272 KCMIL 61/0 STRAND "NARCISSUS" AAC
12.47kV: 336.4 KCMIL 18/1 STRAND "MERLIN" ACSR
DISTRIBUTION NEUTRAL: 336.4 KCMIL 18/1 STRAND "MERLIN" ACSR
ADSS: "AT-XXX27DT-144-CLCB" 144 FIBER

NOTES:

- ALL STATED LOADS ARE ULTIMATE VALUES AND INCLUDE OVERLOAD FACTORS AND INSULATOR WEIGHT.
- STRUCTURE AND ATTACHMENTS SHALL BE DESIGNED FOR THE SIMULTANEOUS APPLICATION OF DEAD LOAD, WIND ON THE STRUCTURE, AND WIRE LOADS FOR EACH LOADING CASE.
- STRUCTURE SHALL BE DESIGNED SELF SUPPORTING, GUYS ARE NOT PERMITTED. STRUCTURE SHALL MEET ALL TECHNICAL REQUIREMENTS OF THE STEEL POLE SPECIFICATIONS.
- WIND PRESSURES SHOWN ON LOAD WORKSHEET ARE BASED ON A SHAPE FACTOR OF 1.0.
- FABRICATOR MAY PROPOSE STRUCTURAL DETAILS DIFFERENT THAN THOSE SHOWN TO SIMPLIFY FABRICATION. VARIATIONS SHALL BE SUBMITTED TO ENGINEER IN WRITING.
- MINIMUM VANG PLATE THICKNESS = 1/2".
- WIND SHALL BE APPLIED IN THE DIRECTION WHICH RESULTS IN THE MOST SEVERE EFFECT.
- THE DEFLECTION AT THE POLE TOP SHALL BE LIMITED TO 1.5% OF THE POLE HEIGHT UNDER THE DEFLECTION CASE. POLES MAY BE CAMBERED TO FALL WITHIN THE DESIGN LIMIT.
- MAXIMUM DEFLECTION AT TOP OF THE STRUCTURE SHALL BE LIMITED TO 10% OF STRUCTURE HEIGHT UNDER ALL LOAD CASES WITH THE EXCEPTION TO THE 60° NO WIND LOAD CASE.
- POLE DESIGN AND FABRICATION SHALL INCLUDE PROVISIONS FOR A SLIP JOINT TO LIMIT LOWEST POLE SEGMENT EXTENSION ABOVE GRADE TO 12'-0" MAXIMUM.
- ALL STRUCTURES SHALL BE GALVANIZED STEEL.
- ORIENT SINGLE SIDED VANGS FOR HARDWARE SHOWN ON DRAWINGS.
- MANUFACTURER SHALL APPLY POINT LOADS NECESSARY TO CREATE THE MOST SEVERE EFFECTS ON ALL MEMBERS INCLUDING ARMS, POLES, BASE PLATES, ETC.

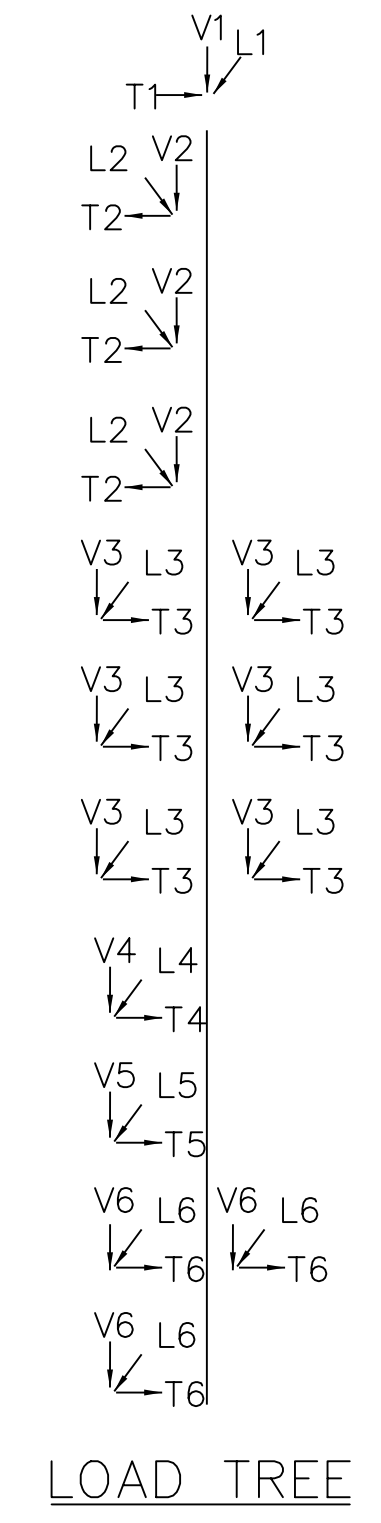

NO.	REVISIONS
A	MT. PLEASANT TO SUGG T-LINE ISSUED FOR BID ENGINEERS: S.E DATE: 12/03/21

CONSTRUCTION NOTE:
REMOVE OLD WIRE LABELS WITH ORANGE TEXT,
INSTALL NEW WIRE LABELS WITH GREEN TEXT

ISSUED FOR BID

GREENVILLE UTILITIES
Greenville, North Carolina

115kV TRANSMISSION LINE
MT. PLEASANT SUB TO SUGG
LOAD AND DESIGN
RUNNING ANGLE WITH UNDERBUILD

DWN.D. CHAMBLISS DATE 12/03/21 DWG. NO.
CKD. R. DILLABOUGH APPD. S. ECKMAN RA-15L_Ver1_1-CT_STR-61
SCALE: NONE

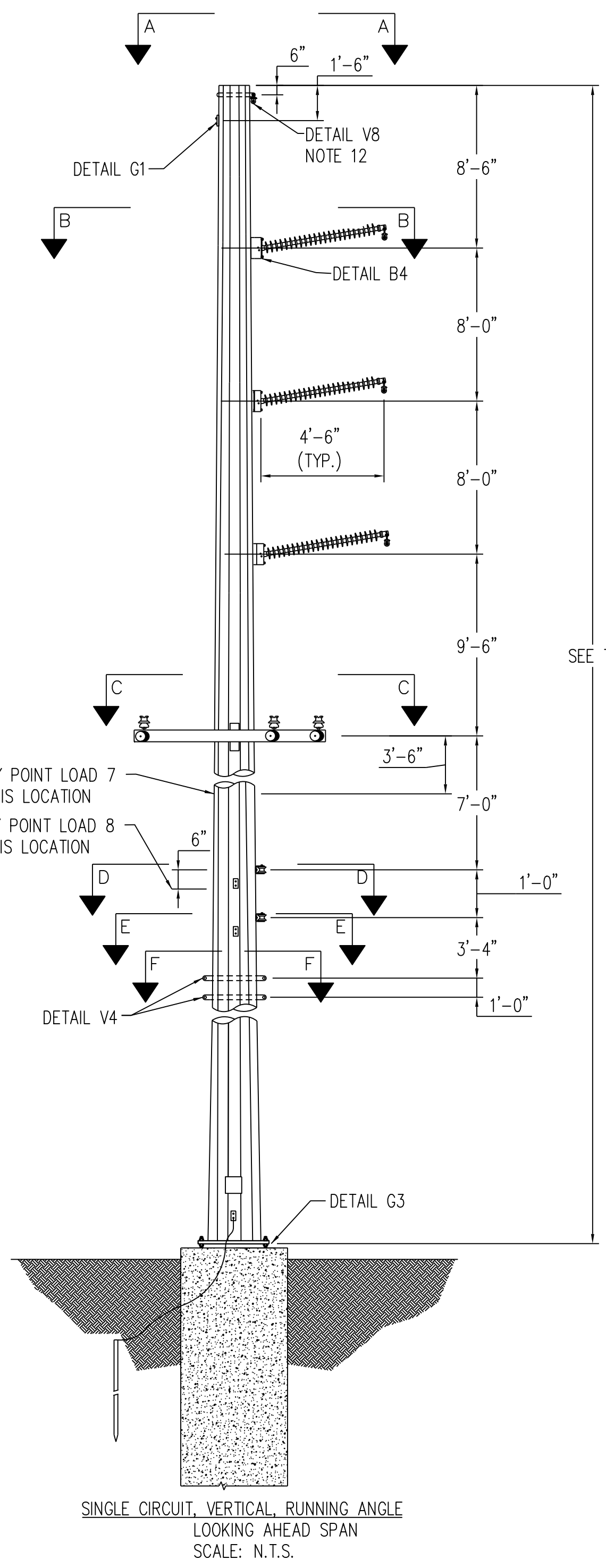

SEE TABLE

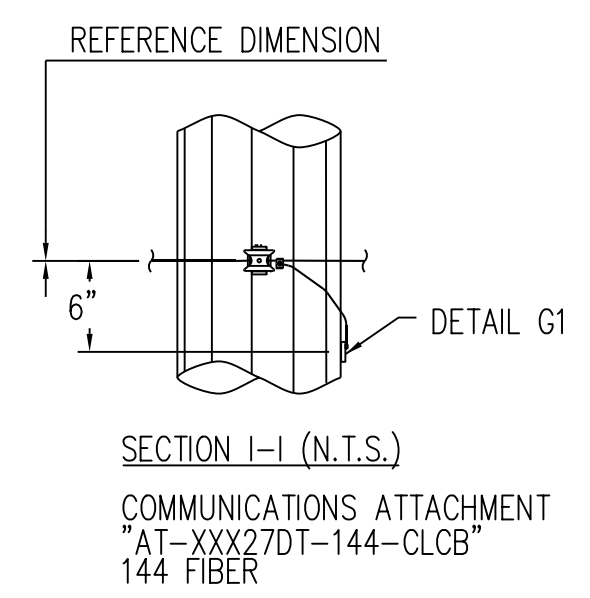
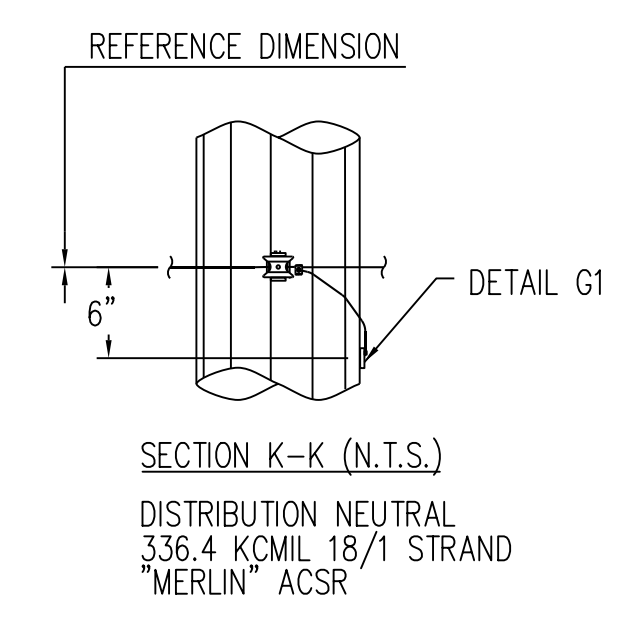
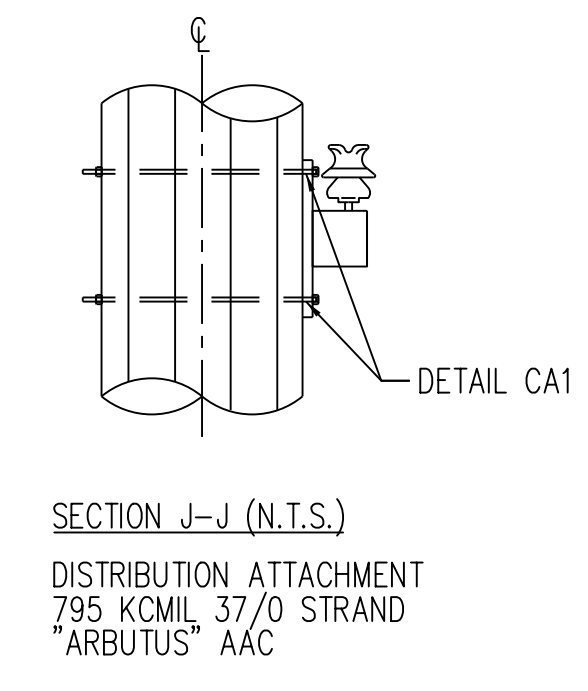
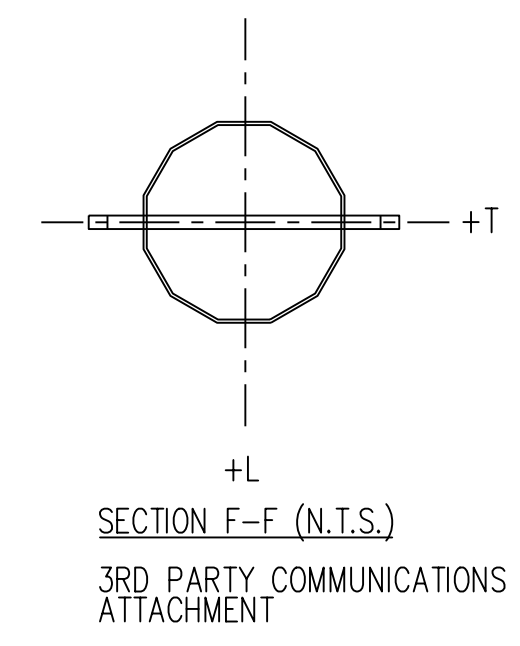
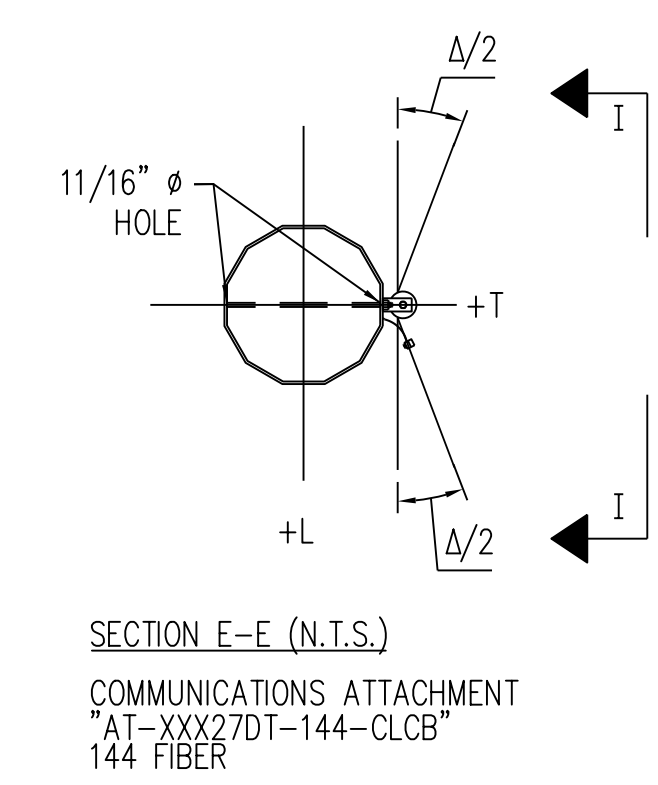
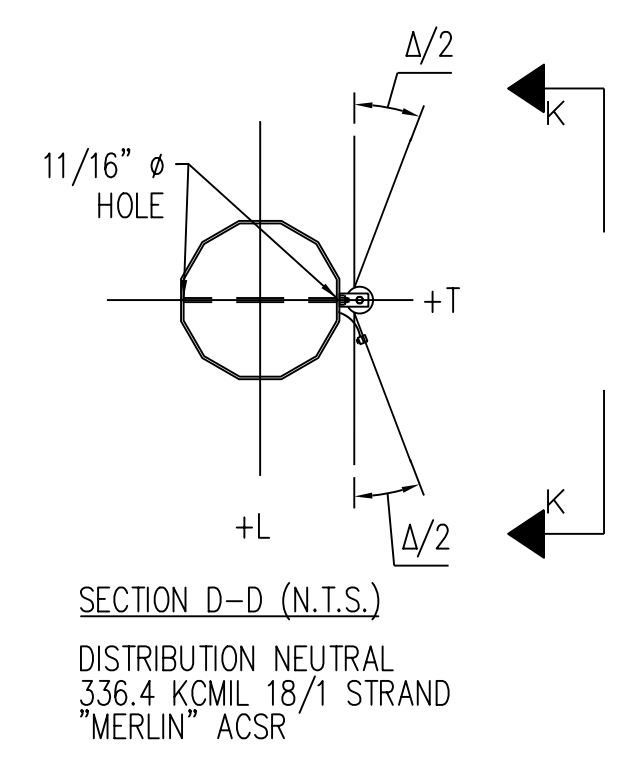
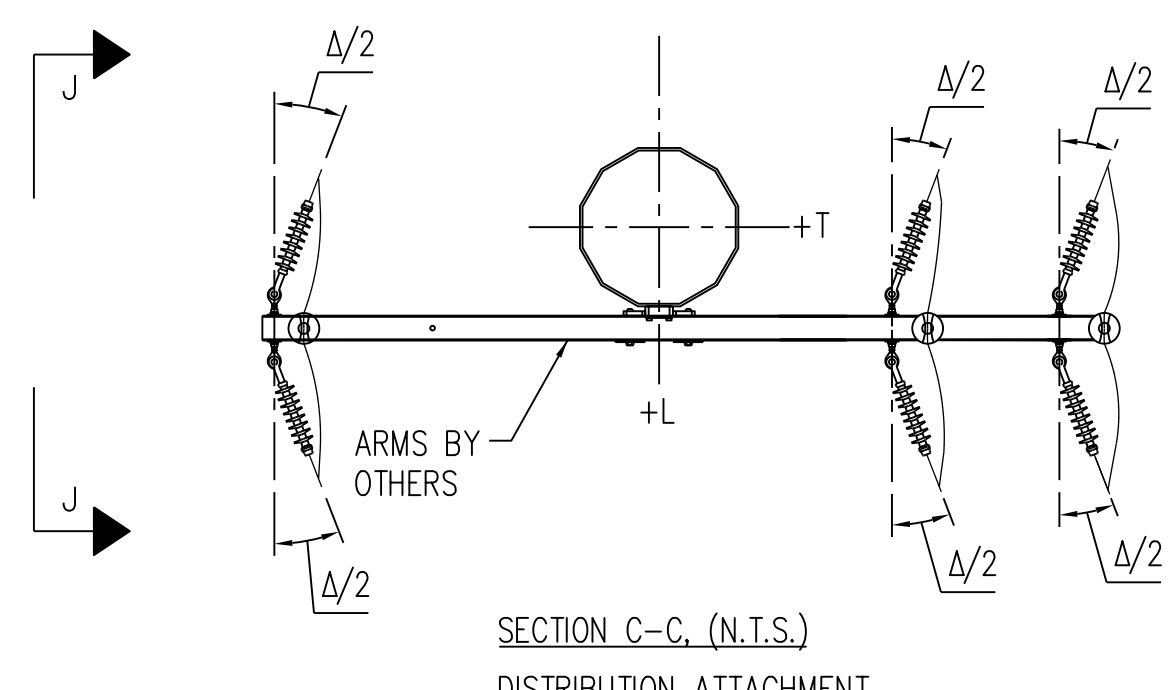
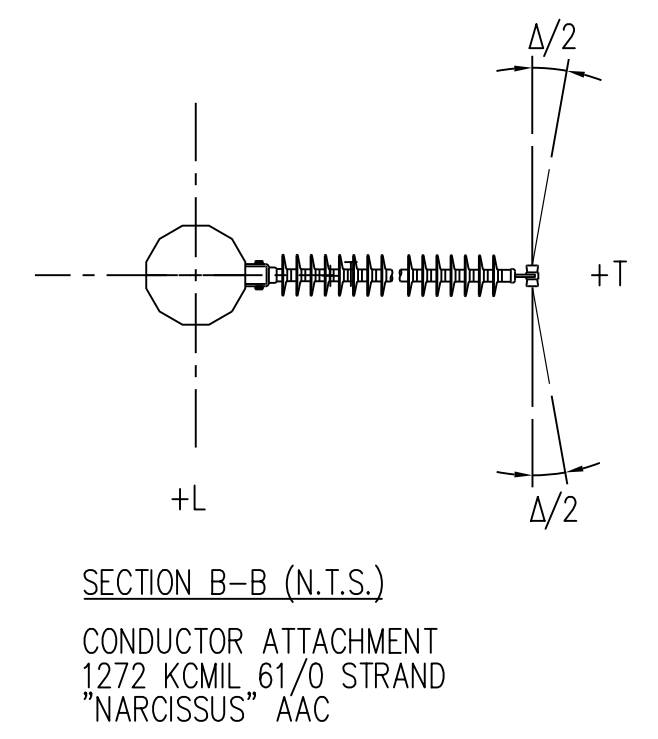
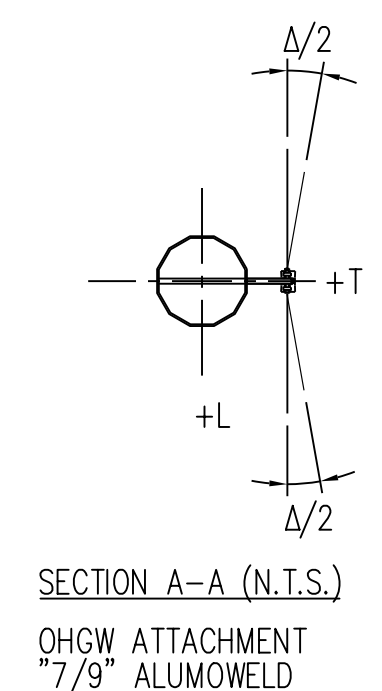

STR #	HEIGHT (FT)	ANGLE Δ
11	75	7

LOAD	LOADING TABLE				
	CASE 1	CASE 2	CASE 3	CASE 7	CASE 9
V1	200	200	600	100	600
T1	1100	900	1200	200	1100
L1	-100	-100	-100	-100	-300
V2	900	500	1300	400	1400
T2	4300	3600	3400	1000	3100
L2	-100	-100	-100	-100	-200
V3	500	300	1000	300	1000
T3	3900	5800	2800	600	2300
V4	400	200	900	200	900
T4	2000	1700	1800	400	1600
L4	-100	-100	-100	-100	-1000
V5	300	100	800	100	900
T5	900	1200	900	200	700
L5	-100	-100	-100	-100	-700
V6	500	200	1000	200	1100
T6	900	1600	1000	100	700
L6	-100	-100	-100	-	-600
V7	500	200	1600	200	200
T7	-1900	-900	-1500	-600	-1600
L7	-400	-200	-300	-100	-300
V8	500	200	1600	200	200
T8	-1900	-900	-1500	-600	-1600
L8	-400	-200	-300	-100	-300
W(PSF)	10	36.9	4.1	0	0

ALL LOADS ARE IN LBS, ARE ULTIMATE, AND INCLUDE ALL OVERLOAD FACTORS. "W" REPRESENTS WIND PRESSURE (psf) TO BE APPLIED TO STRUCTURE.

LOAD CASES

- CASE 1 NESO MEDIUM: 15°, .25" ICE, 4 PSF WIND
OLF: L=1.65, T=2.50, V=1.50
- CASE 2 NESO HIGH WIND: 60°, 0" ICE, 120 MPH WIND
OLF: L=1.00, T=1.00, V=1.00
- CASE 3 NESO ICE WITH WIND: 15°, 1" ICE, 40 MPH WIND
OLF: L=1.00, T=1.00, V=1.00
- CASE 7 DEFLECTION: 60 DEGREES, NO ICE, NO WIND, FINAL
OLF: L=1.00, T=1.00, V=1.00
- CASE 9 UNBALANCED ICE: 32 DEGREES, 1" ICE, NO WIND
OLF: L=1.10, T=1.10, V=1.10

WIRE DATA

OHGW: "7#9" ALUMOWELD
115KV: 1272 KCMIL 61/0 STRAND "NARCISSUS" AAC
12.47kV: 795 KCMIL 37/0 STRAND "ARBUTUS" AAC
DISTRIBUTION NEUTRAL: 336.4 KCMIL 18/1 STRAND "MERLIN" ACSR
ADSS: "AT-XXX27DT-144-CLCB" 144 FIBER

NOTES:

- ALL STATED LOADS ARE ULTIMATE VALUES AND INCLUDE OVERLOAD FACTORS AND INSULATOR WEIGHT.
- STRUCTURE AND ATTACHMENTS SHALL BE DESIGNED FOR THE SIMULTANEOUS APPLICATION OF DEAD LOAD, WIND ON THE STRUCTURE, AND WIRE LOADS FOR EACH LOADING CASE.
- STRUCTURE SHALL BE DESIGNED SELF SUPPORTING, GUYS ARE NOT PERMITTED. STRUCTURE SHALL MEET ALL TECHNICAL REQUIREMENTS OF THE STEEL POLE SPECIFICATIONS.
- WIND PRESSURES SHOWN ON LOAD WORKSHEET ARE BASED ON A SHAPE FACTOR OF 1.0.
- FABRICATOR MAY PROPOSE STRUCTURAL DETAILS DIFFERENT THAN THOSE SHOWN TO SIMPLIFY FABRICATION. VARIATIONS SHALL BE SUBMITTED TO ENGINEER IN WRITING.
- MINIMUM VANG PLATE THICKNESS = 1/2".
- WIND SHALL BE APPLIED IN THE DIRECTION WHICH RESULTS IN THE MOST SEVERE EFFECT.
- THE DEFLECTION AT THE POLE TOP SHALL BE LIMITED TO 1.5% OF THE POLE HEIGHT UNDER THE DEFLECTION CASE. POLES MAY BE CAMBERED TO FALL WITHIN THE DESIGN LIMIT.
- MAXIMUM DEFLECTION AT TOP OF THE STRUCTURE SHALL BE LIMITED TO 10% OF STRUCTURE HEIGHT UNDER ALL LOAD CASES WITH THE EXCEPTION TO THE 60° NO WIND LOAD CASE.
- POLE DESIGN AND FABRICATION SHALL INCLUDE PROVISIONS FOR A SLIP JOINT TO LIMIT LOWEST POLE SEGMENT EXTENSION ABOVE GRADE TO 12'-0" MAXIMUM.
- ALL STRUCTURES SHALL BE GALVANIZED STEEL.
- ORIENT SINGLE SIDED VANGS FOR HARDWARE SHOWN ON DRAWINGS.
- MANUFACTURER SHALL APPLY POINT LOADS NECESSARY TO CREATE THE MOST SEVERE EFFECTS ON ALL MEMBERS INCLUDING ARMS, POLES, BASE PLATES, ETC.

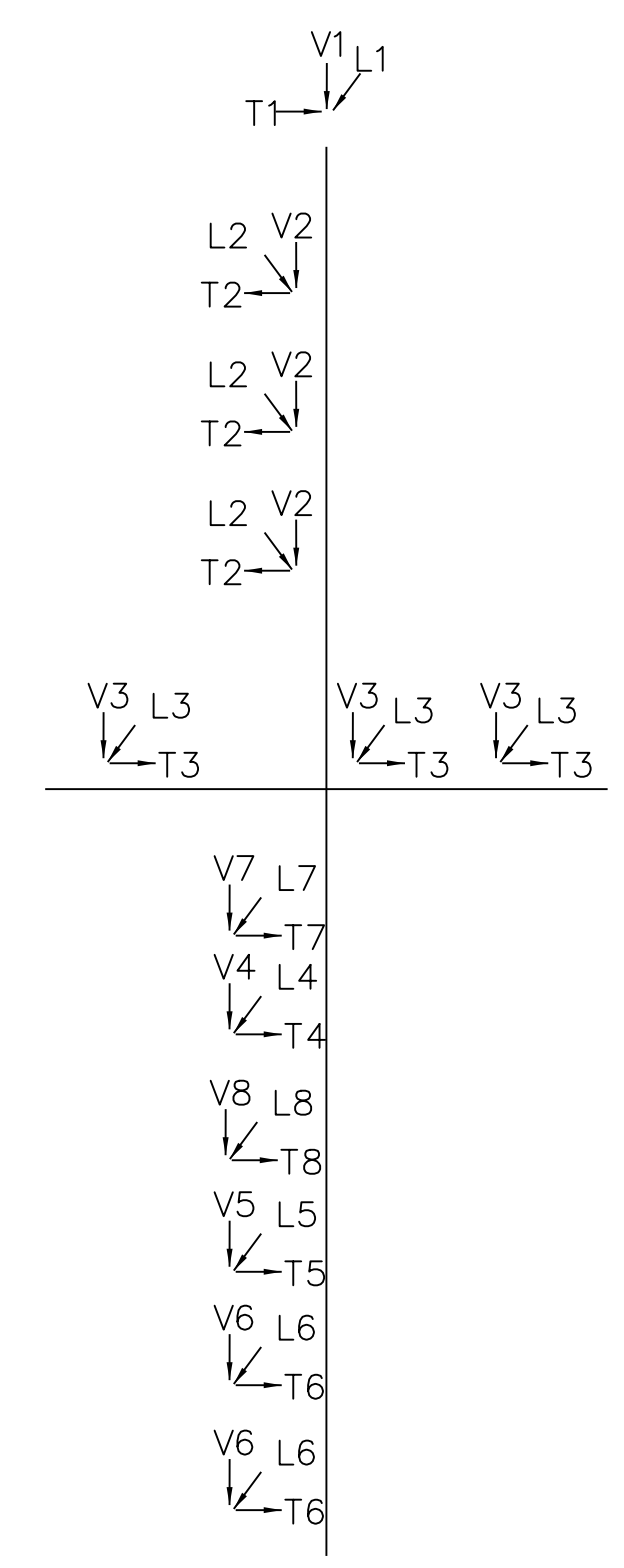

LOAD TREE

NO.	REVISIONS
A	MT. PLEASANT TO SUGG T-LINE ISSUED FOR BID ENGINEER'S S.E DATE: 12/03/21

CONSTRUCTION NOTE:
REMOVE OLD WIRE LABELS WITH ORANGE TEXT,
INSTALL NEW WIRE LABELS WITH GREEN TEXT

ISSUED FOR BID

GREENVILLE UTILITIES
Greenville, North Carolina

115KV TRANSMISSION LINE
MT. PLEASANT SUB TO SUGG
LOAD AND DESIGN
RUNNING ANGLE 10° WITH UNDERBUILD

DWIND. CHAMBLISS DATE 12/03/21 DWG. NO.
CKD. R. DILLABOUGH APPD. S. ECKMAN RA-15R_FFD_1.5-CT
SCALE: NONE

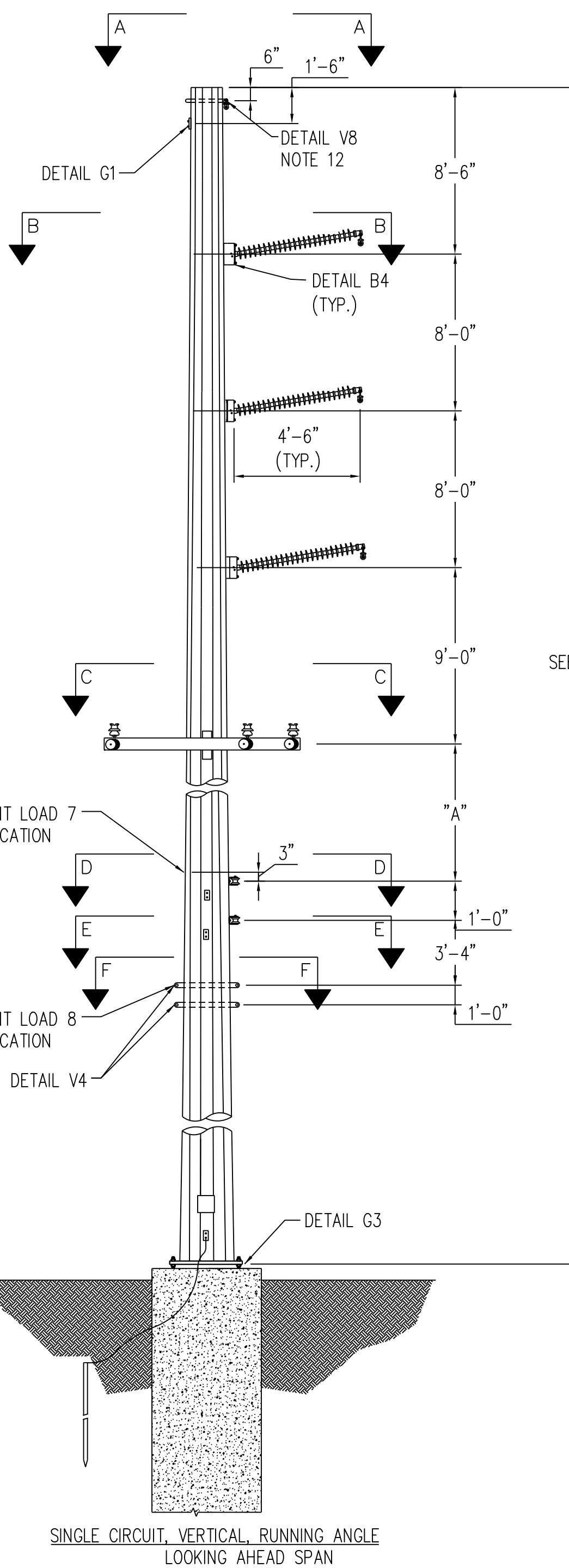

STR #	HEIGHT (FT)	DIMENSION "A" (FT)	ANGLE Δ
13	75	7	8
21	90	7	10
38	75	7	4
42	85	7	4
49	85	7	10
50	80	7	15
100	80	10	7
101*	80	7	10
102	80	7	7
145*	80	7	6

LOAD	LOADING TABLE				
	CASE 1	CASE 2	CASE 3	CASE 7	CASE 9
V1	300	100	600	100	700
T1	-1000	-800	-1200	-200	-1000
L1	-100	-100	-100	-	-300
V2	900	500	1400	500	1500
T2	-3700	-3000	-2900	-600	-2600
L2	-100	-100	-100	-100	-200
V3	600	300	1000	300	1100
T3	-3700	-5500	-2700	-500	-2100
L3	-100	-100	-100	-100	-1100
V4	400	200	800	200	900
T4	-1900	-1500	-1700	-300	-1400
L4	-100	-100	-100	-	-900
V5	300	200	800	100	900
T5	-800	-1000	-800	-200	-600
L5	-100	-100	-100	-	-500
V6	500	200	1000	200	1100
T6	-800	-1300	-900	-100	-700
L6	-100	-100	-100	-	-400
V7	500	100	1600	100	100
T7	600	700	700	100	500
L7	-100	-100	-100	-100	-100
V8	1100	400	2500	400	400
T8	1900	2100	1700	600	1400
L8	-300	-300	-300	-100	-300
W(PSF)	10	36.9	4.1	0	0

- LOAD CASES**
- CASE 1 NESC MEDIUM: 15°, .25" ICE, 4 PSF WIND
OLF: L=1.65, T=2.50, V=1.50
- CASE 2 NESC HIGH WIND: 60°, 0" ICE, 120 MPH WIND
OLF: L=1.00, T=1.00, V=1.00
- CASE 3 NESC ICE WITH WIND: 15°, 1" ICE, 40 MPH WIND
OLF: L=1.00, T=1.00, V=1.00
- CASE 7 DEFLECTION: 60 DEGREES, NO ICE, NO WIND, FINAL
OLF: L=1.00, T=1.00, V=1.00
- CASE 9 UNBALANCED ICE: 32 DEGREES, 1" ICE, NO WIND
OLF: L=1.10, T=1.10, V=1.10

WIRE DATA

OHGW: "7#9" ALUMOWELD
115KV: 1272 KCMIL 61/0 STRAND "NARCISSUS" AAC
12.47KV: 795 KCMIL 37/0 STRAND "ARBUSUS" AAC
DISTRIBUTION NEUTRAL: 336.4 KCMIL 18/1 STRAND "MERLIN" ACSR
ADSS: "AT-XXX27DT-144-CLCB" 144 FIBER

- NOTES:**
- ALL STATED LOADS ARE ULTIMATE VALUES AND INCLUDE OVERLOAD FACTORS AND INSULATOR WEIGHT.
 - STRUCTURE AND ATTACHMENTS SHALL BE DESIGNED FOR THE SIMULTANEOUS APPLICATION OF DEAD LOAD, WIND ON THE STRUCTURE, AND WIRE LOADS FOR EACH LOADING CASE. STRUCTURE SHALL BE DESIGNED SELF SUPPORTING, GUYS ARE NOT PERMITTED. STRUCTURE SHALL MEET ALL TECHNICAL REQUIREMENTS OF THE STEEL POLE SPECIFICATIONS.
 - WIND PRESSURES SHOWN ON LOAD WORKSHEET ARE BASED ON A SHAPE FACTOR OF 1.0.
 - FABRICATOR MAY PROPOSE STRUCTURAL DETAILS DIFFERENT THAN THOSE SHOWN TO SIMPLIFY FABRICATION. VARIATIONS SHALL BE SUBMITTED TO ENGINEER IN WRITING.
 - MINIMUM VANG PLATE THICKNESS = 1/2".
 - WIND SHALL BE APPLIED IN THE DIRECTION WHICH RESULTS IN THE MOST SEVERE EFFECT.
 - THE DEFLECTION AT THE POLE TOP SHALL BE LIMITED TO 1.5% OF THE POLE HEIGHT UNDER THE DEFLECTION CASE. POLES MAY BE CAMBERED TO FALL WITHIN THE DESIGN LIMIT.
 - MAXIMUM DEFLECTION AT TOP OF THE STRUCTURE SHALL BE LIMITED TO 10% OF STRUCTURE HEIGHT UNDER ALL LOAD CASES WITH THE EXCEPTION TO THE 60° NO WIND LOAD CASE.
 - POLE DESIGN AND FABRICATION SHALL INCLUDE PROVISIONS FOR A SLIP JOINT TO LIMIT LOWEST POLE SEGMENT EXTENSION ABOVE GRADE TO 12'-0" MAXIMUM.
 - ALL STRUCTURES SHALL BE GALVANIZED STEEL.
 - ORIENT SINGLE SIDED VANGS FOR HARDWARE SHOWN ON DRAWINGS.
 - MANUFACTURER SHALL APPLY POINT LOADS NECESSARY TO CREATE THE MOST SEVERE EFFECTS ON ALL MEMBERS INCLUDING ARMS, POLES, BASE PLATES, ETC.

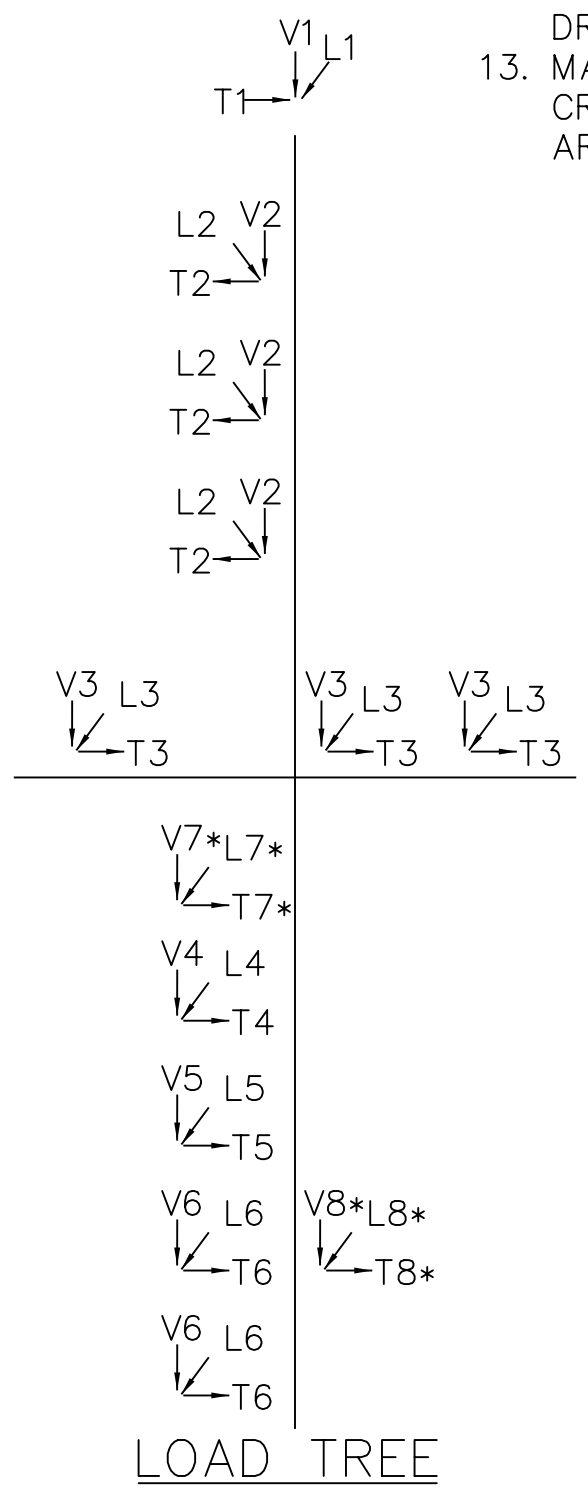
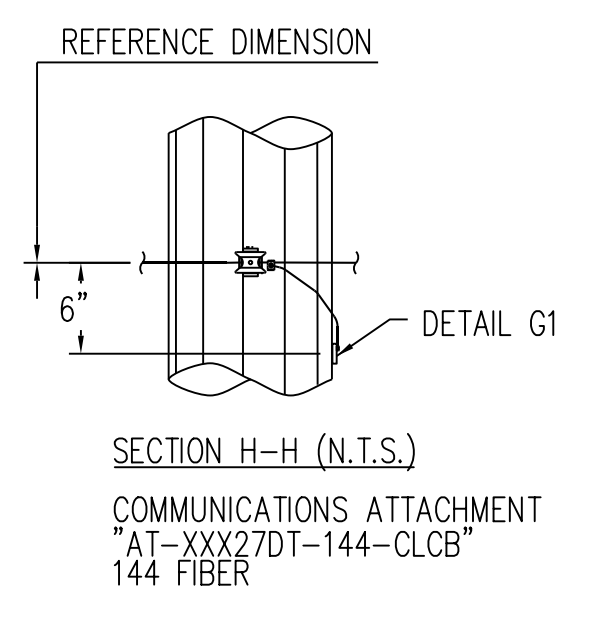
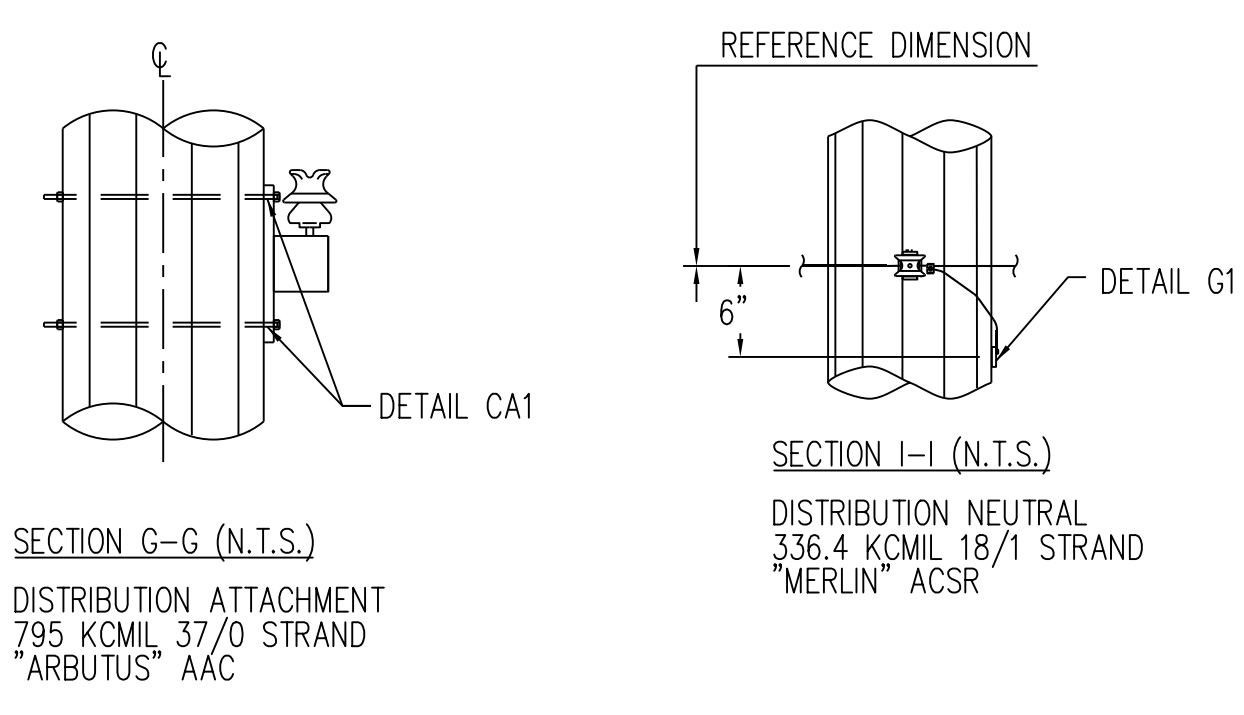
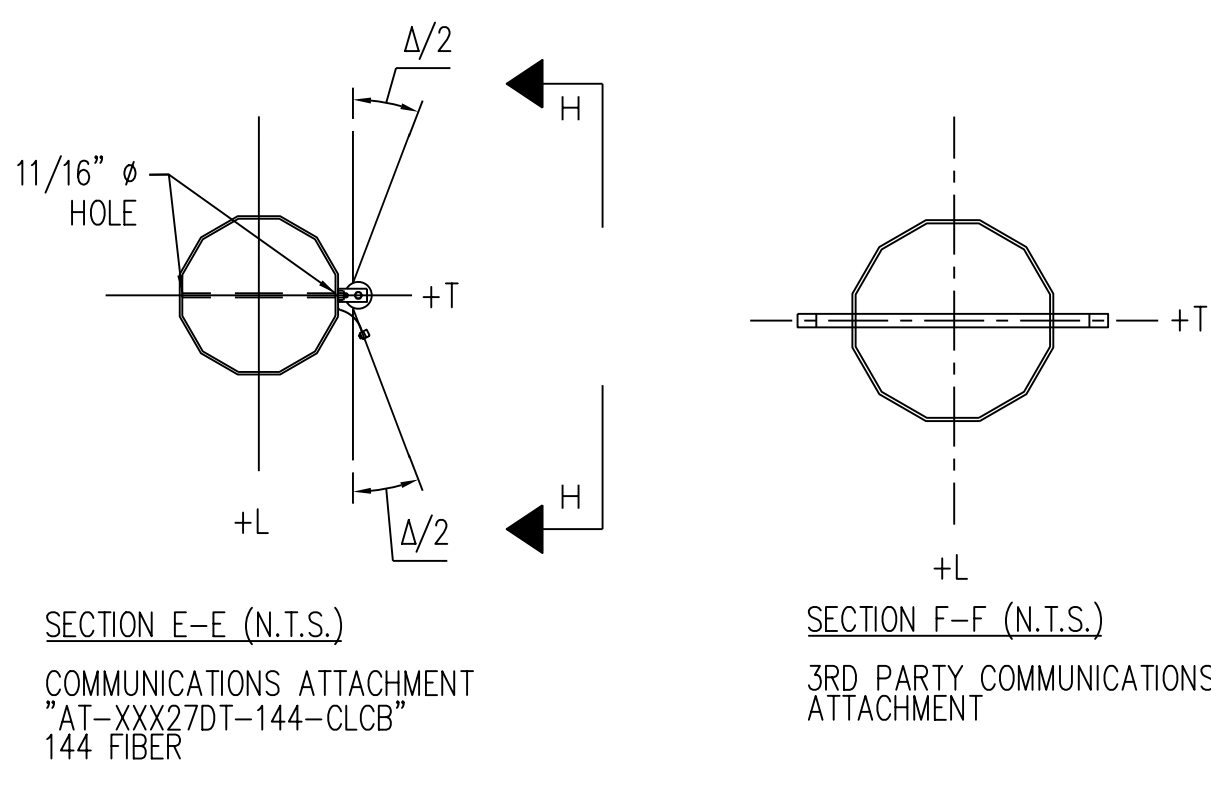
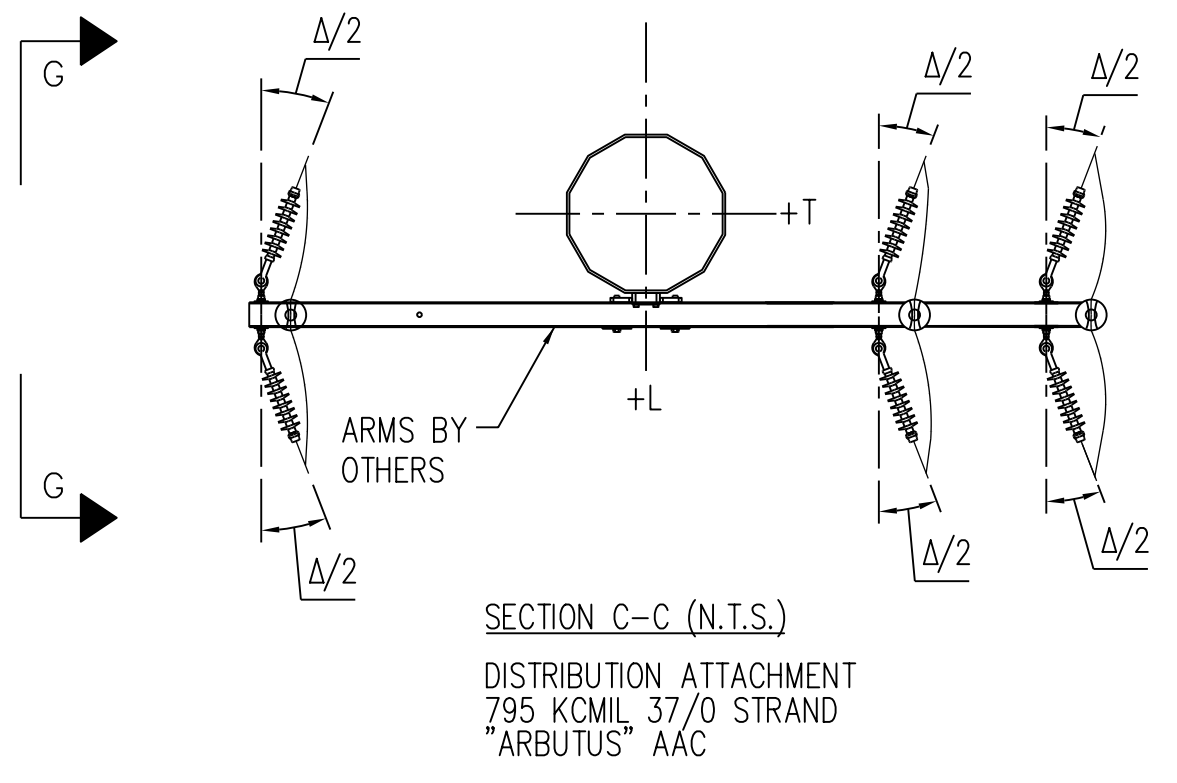
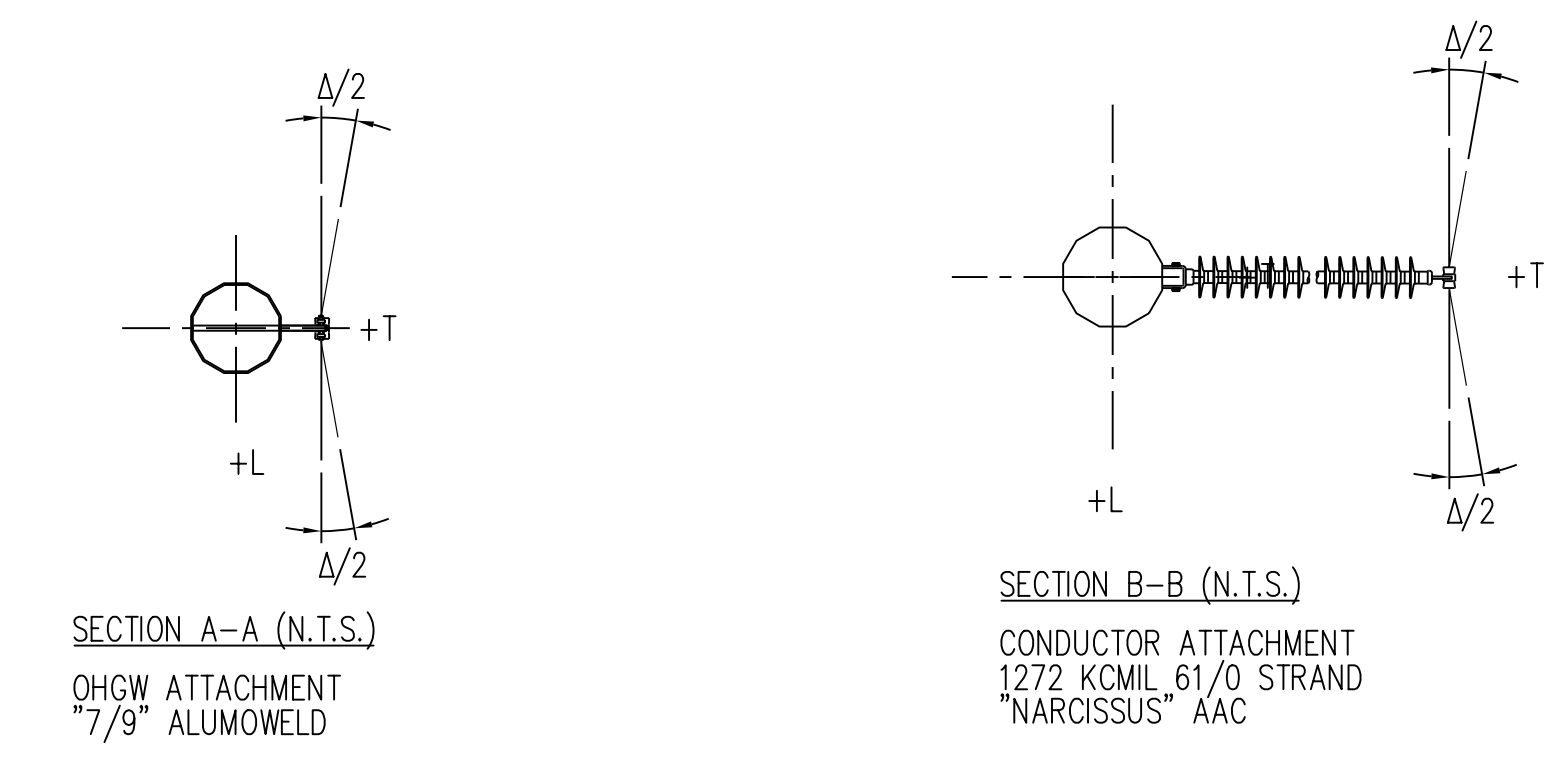

ALL LOADS ARE IN LBS, ARE ULTIMATE, AND INCLUDE ALL OVERLOAD FACTORS. "W" REPRESENTS WIND PRESSURE (psf) TO BE APPLIED TO STRUCTURE.

* APPLY POINT LOAD 7 AND 8 TO STRUCTURE 101 AND 145 ONLY.

NO.	A
REVISIONS	MT. PLEASANT TO SUGG T-LINE ISSUED FOR BID ENGINEER'S S.E. DATE: 12/03/21

CONSTRUCTION NOTE:
REMOVE OLD WIRE LABELS WITH ORANGE TEXT,
INSTALL NEW WIRE LABELS WITH GREEN TEXT

ISSUED FOR BID

GREENVILLE UTILITIES
Greenville, North Carolina

115KV TRANSMISSION LINE
MT. PLEASANT SUB TO SUGG
LOAD AND DESIGN
RUNNING ANGLE WITH UNDERBUILD

DWN.D. CHAMBLISS DATE 12/03/21 DWG. NO.
CKD. R. DILLABOUGH APPD. S. ECKMAN RA-15R_FFD_1-CY
SCALE: NONE

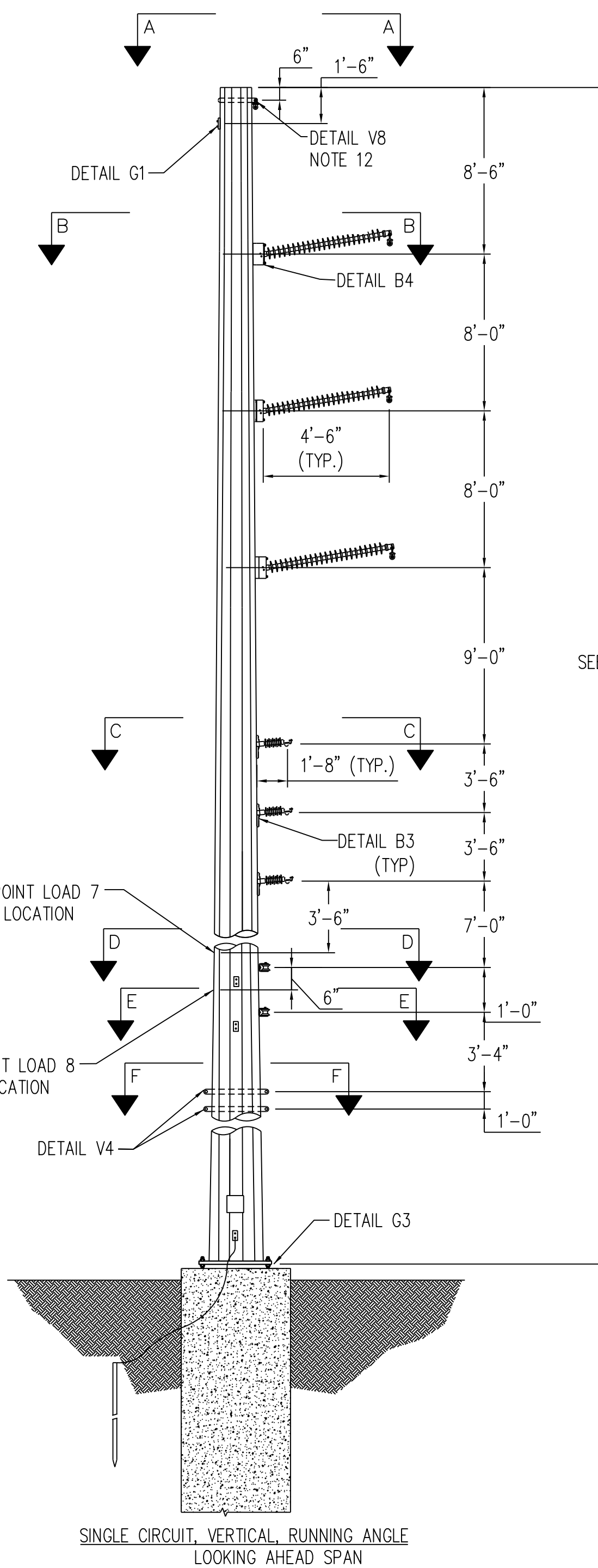

SEE TABLE

STR #	HEIGHT (FT)	ANGLE Δ
142	80	4

LOAD	LOADING TABLE				
	CASE 1	CASE 2	CASE 3	CASE 7	CASE 9
V1	200	200	600	100	600
T1	1100	900	1200	200	1100
L1	-100	-100	-100	-100	-300
V2	900	500	1300	400	1400
T2	4300	3600	3400	1000	3100
L2	-100	-100	-100	-100	-200
V3	500	300	1000	300	1000
T3	3900	5800	2800	600	2300
L3	-100	-100	-100	-100	-1300
V4	400	200	900	200	900
T4	2000	1700	1800	400	1600
L4	-100	-100	-100	-100	-1000
V5	300	100	800	100	900
T5	900	1200	900	200	700
L5	-100	-100	-100	-100	-700
V6	500	200	1000	200	1100
T6	900	1600	1000	100	700
L6	-100	-100	-100	-	-600
V7	600	200	2100	200	200
T7	1800	1000	1300	500	1000
L7	-1000	-500	-700	-300	-600
V8	600	200	2100	200	200
T8	1100	700	900	100	700
L8	-600	-300	-400	-100	-400
W(P5F)	10	36.9	4.1	0	0

ALL LOADS ARE IN LBS, ARE ULTIMATE, AND INCLUDE ALL OVERLOAD FACTORS. "W" REPRESENTS WIND PRESSURE (psf) TO BE APPLIED TO STRUCTURE.

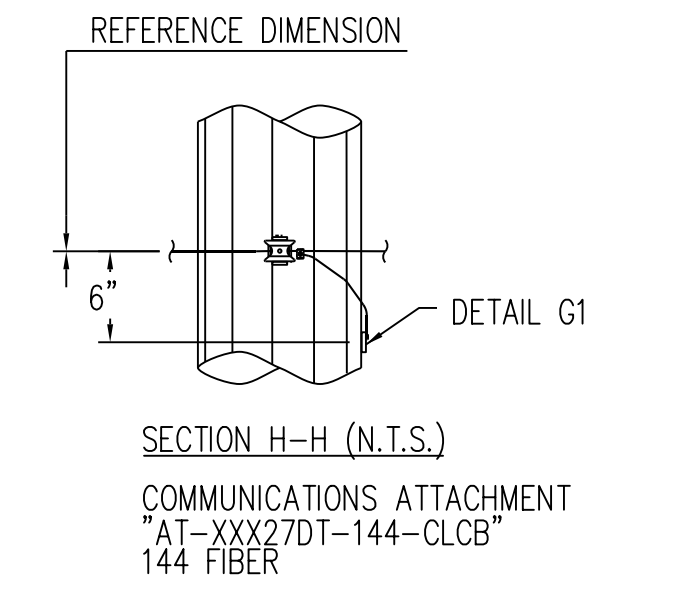
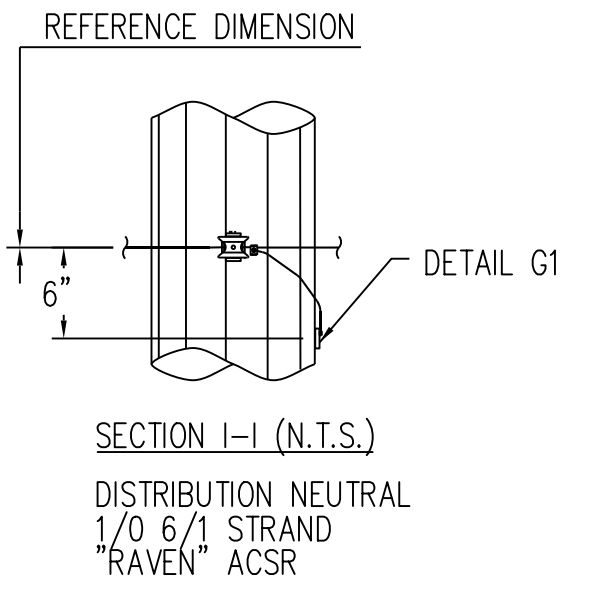
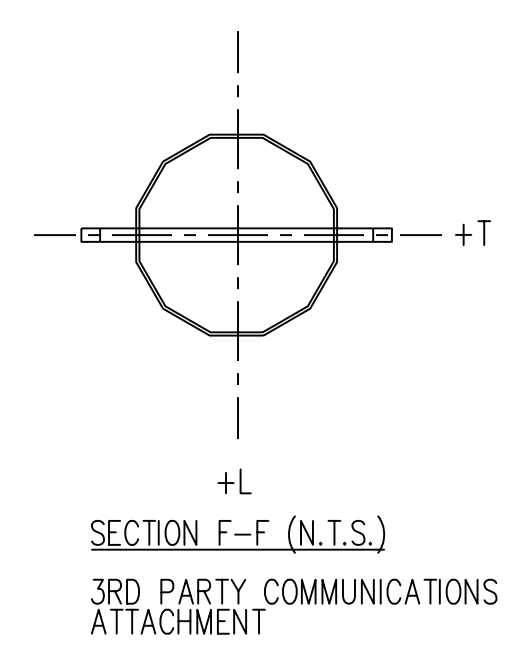
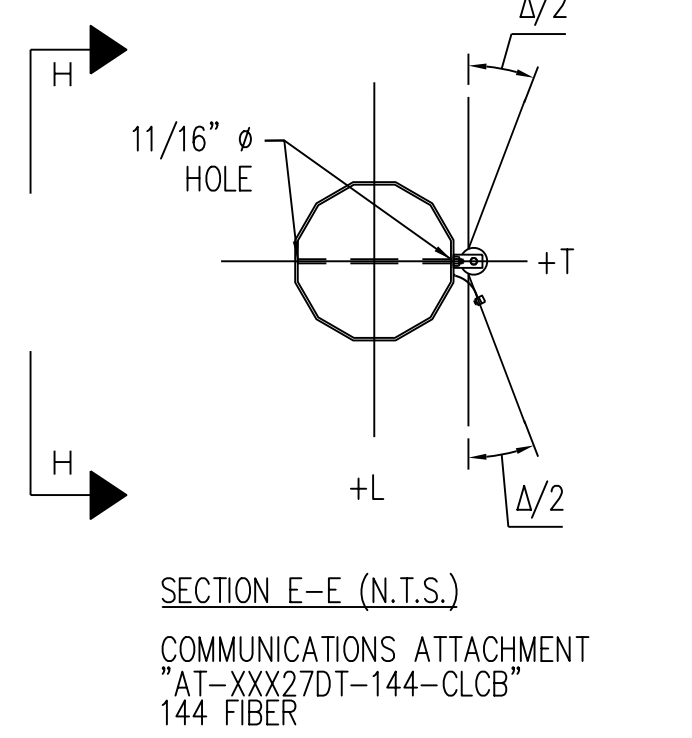
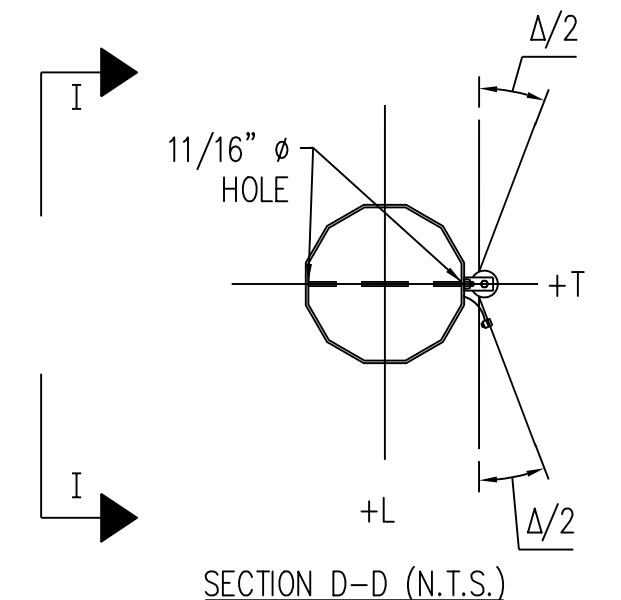
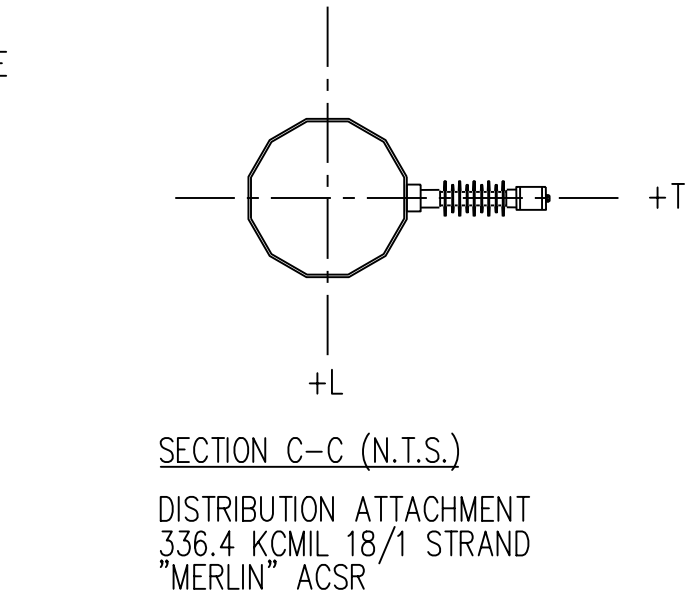
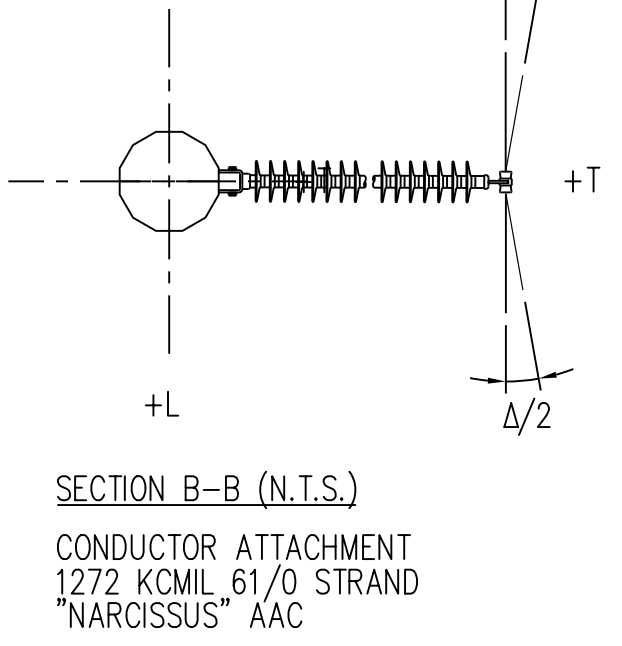
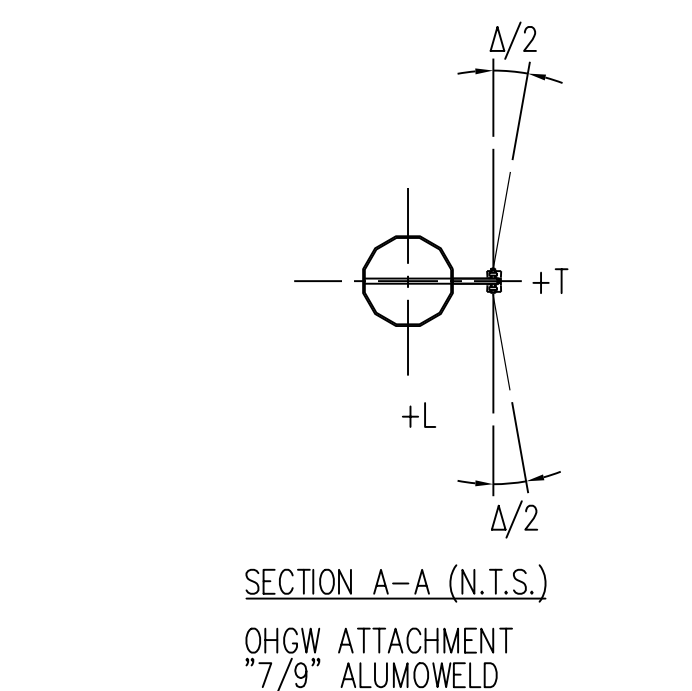

LOAD CASES

- CASE 1 NESC MEDIUM: 15°, .25" ICE, 4 PSF WIND
OLF: L=1.65, T=2.50, V=1.50
- CASE 2 NESC HIGH WIND: 60°, 0" ICE, 120 MPH WIND
OLF: L=1.00, T=1.00, V=1.00
- CASE 3 NESC ICE WITH WIND: 15°, 1" ICE, 40 MPH WIND
OLF: L=1.00, T=1.00, V=1.00
- CASE 7 DEFLECTION: 60 DEGREES, NO ICE, NO WIND, FINAL
OLF: L=1.00, T=1.00, V=1.00
- CASE 9 UNBALANCED ICE: 32 DEGREES, 1" ICE, NO WIND
OLF: L=1.10, T=1.10, V=1.10

WIRE DATA

OHGW: "7#9" ALUMOWELD
 115kV: 1272 KCMIL 61/0 STRAND "NARCISSUS" AAC
 12.47kV: 336.4 KCMIL 18/1 STRAND "MERLIN" ACSR
 DISTRIBUTION NEUTRAL: 1/0 6/1 STRAND "RAVEN" ACSR
 ADSS: "AT-XXX27DT-144-CLCB" 144 FIBER

NOTES:

- ALL STATED LOADS ARE ULTIMATE VALUES AND INCLUDE OVERLOAD FACTORS AND INSULATOR WEIGHT.
- STRUCTURE AND ATTACHMENTS SHALL BE DESIGNED FOR THE SIMULTANEOUS APPLICATION OF DEAD LOAD, WIND ON THE STRUCTURE, AND WIRE LOADS FOR EACH LOADING CASE.
- STRUCTURE SHALL BE DESIGNED SELF SUPPORTING, GUYS ARE NOT PERMITTED. STRUCTURE SHALL MEET ALL TECHNICAL REQUIREMENTS OF THE STEEL POLE SPECIFICATIONS.
- WIND PRESSURES SHOWN ON LOAD WORKSHEET ARE BASED ON A SHAPE FACTOR OF 1.0.
- FABRICATOR MAY PROPOSE STRUCTURAL DETAILS DIFFERENT THAN THOSE SHOWN TO SIMPLIFY FABRICATION. VARIATIONS SHALL BE SUBMITTED TO ENGINEER IN WRITING.
- MINIMUM VANG PLATE THICKNESS = 1/2".
- WIND SHALL BE APPLIED IN THE DIRECTION WHICH RESULTS IN THE MOST SEVERE EFFECT.
- THE DEFLECTION AT THE POLE TOP SHALL BE LIMITED TO 1.5% OF THE POLE HEIGHT UNDER THE DEFLECTION CASE. POLES MAY BE CAMBERED TO FALL WITHIN THE DESIGN LIMIT.
- MAXIMUM DEFLECTION AT TOP OF THE STRUCTURE SHALL BE LIMITED TO 10% OF STRUCTURE HEIGHT UNDER ALL LOAD CASES WITH THE EXCEPTION TO THE 60°F NO WIND LOAD CASE.
- POLE DESIGN AND FABRICATION SHALL INCLUDE PROVISIONS FOR A SLIP JOINT TO LIMIT LOWEST POLE SEGMENT EXTENSION ABOVE GRADE TO 12'-0" MAXIMUM.
- ALL STRUCTURES SHALL BE GALVANIZED STEEL.
- ORIENT SINGLE SIDED VANGS FOR HARDWARE SHOWN ON DRAWINGS.
- MANUFACTURER SHALL APPLY POINT LOADS NECESSARY TO CREATE THE MOST SEVERE EFFECTS ON ALL MEMBERS INCLUDING ARMS, POLES, BASE PLATES, ETC.

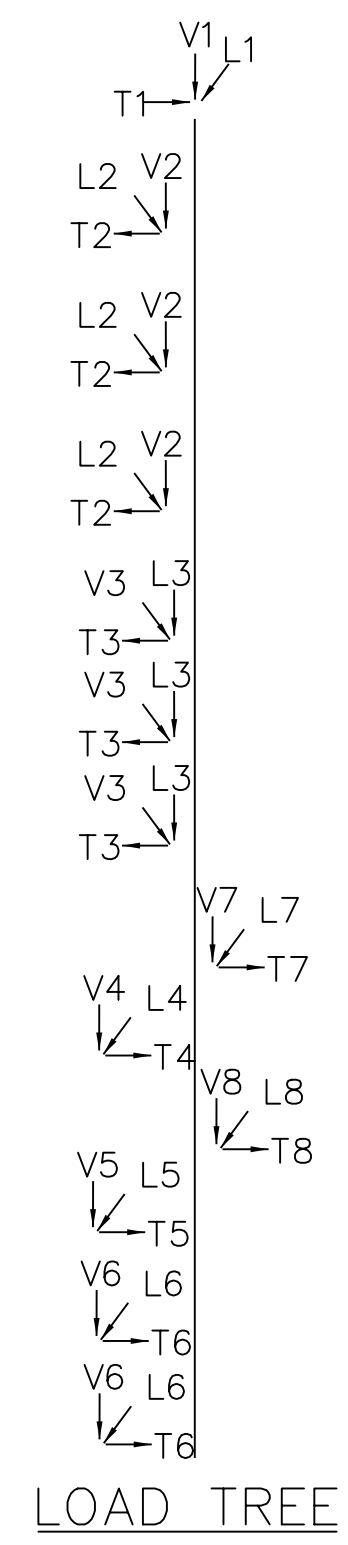

NO.	REVISIONS
A	MT. PLEASANT TO SUGG T-LINE ISSUED FOR BID ENGINEER'S: S.E DATE: 12/03/21

CONSTRUCTION NOTE:
 REMOVE OLD WIRE LABELS WITH ORANGE TEXT,
 INSTALL NEW WIRE LABELS WITH GREEN TEXT

ISSUED FOR BID

GREENVILLE UTILITIES
 Greenville, North Carolina

115kV TRANSMISSION LINE
 MT. PLEASANT SUB TO SUGG
 LOAD AND DESIGN
 RUNNING ANGLE 10° WITH UNDERBUILD

DWIND. CHAMBLISS DATE 12/03/21 DWG. NO.
 CKD. R. DILLABOUGH APPD. S. ECKMAN RA-15R_Vert_1.5-CT
 SCALE: NONE

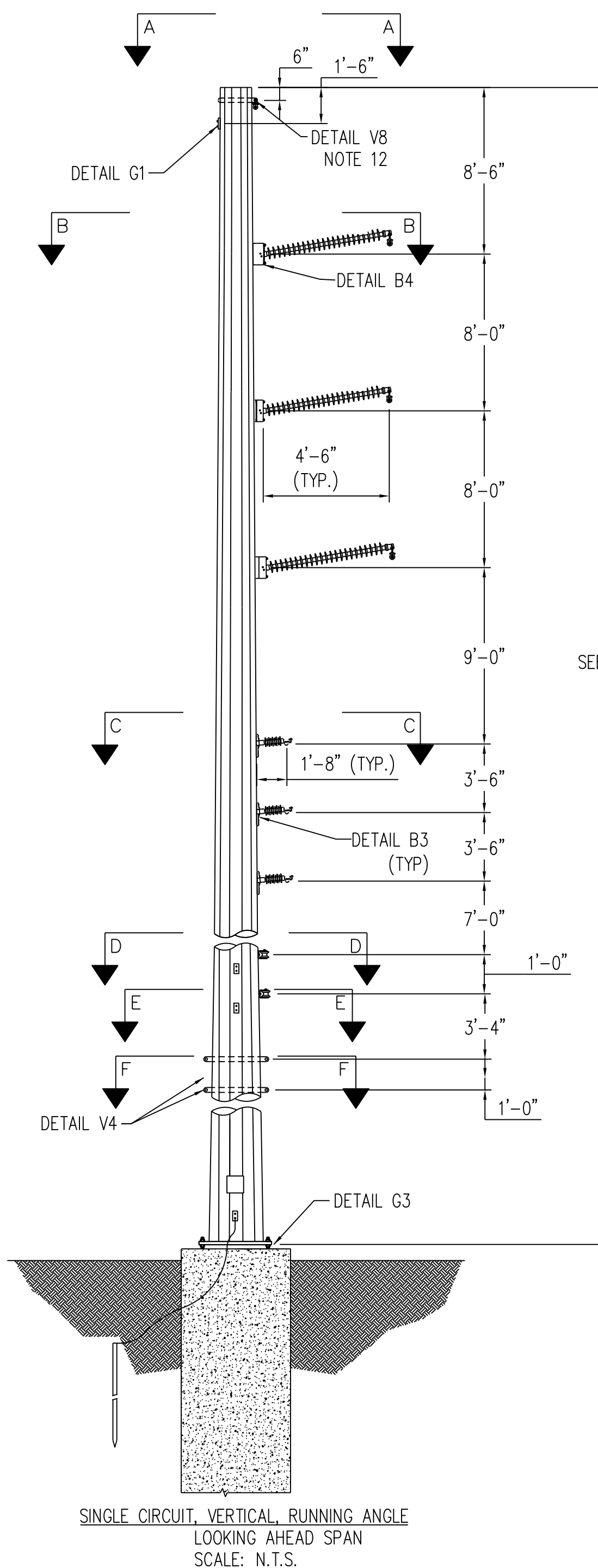

SEE TABLE

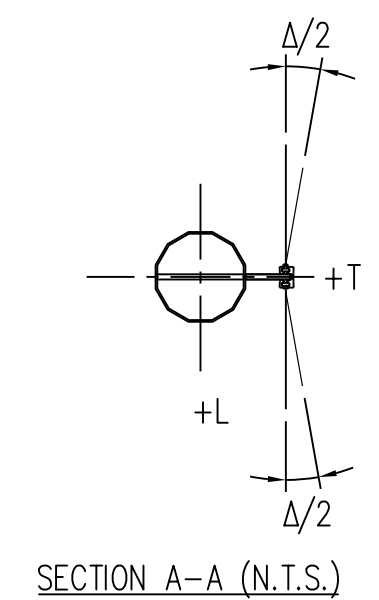

SECTION A-A (N.T.S.)
OHGW ATTACHMENT
"7/9" ALUMOWELD

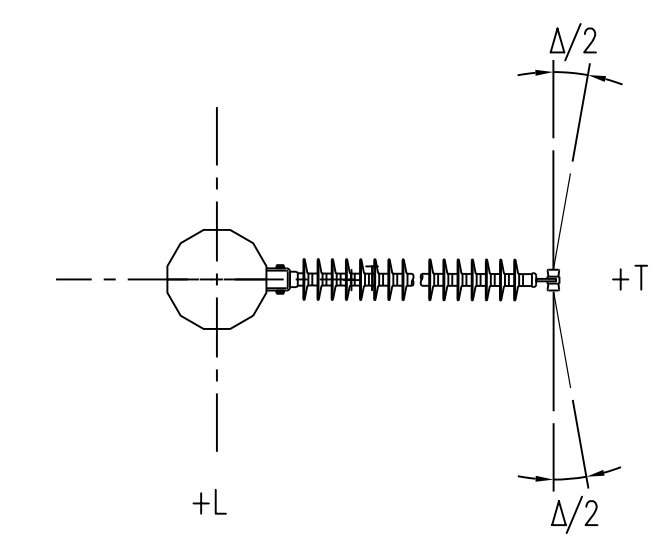

SECTION B-B (N.T.S.)
CONDUCTOR ATTACHMENT
1272 KCMIL 61/0 STRAND
"NARCISSUS" AAC

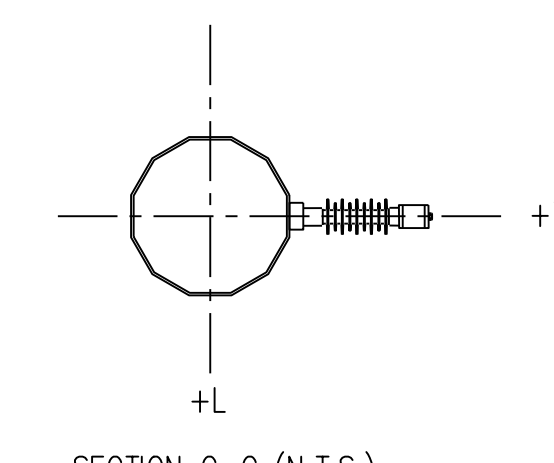

SECTION C-C (N.T.S.)
DISTRIBUTION ATTACHMENT
336.4 KCMIL 18/1 STRAND
"MERLIN" ACSR

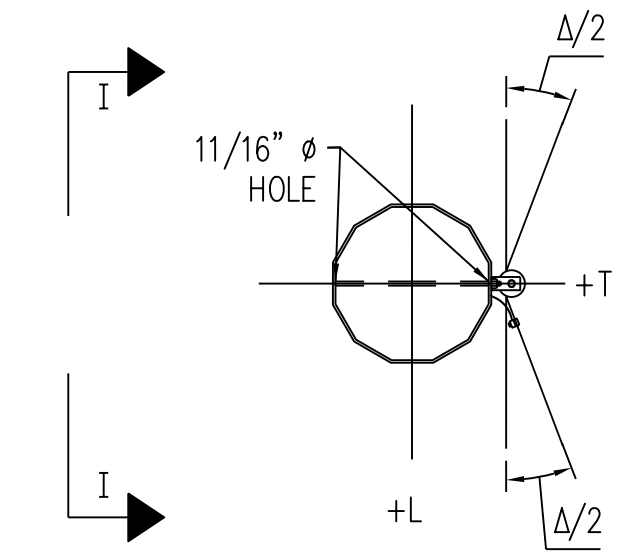

SECTION D-D (N.T.S.)
DISTRIBUTION NEUTRAL
1/0 6/1 STRAND
"RAVEN" ACSR

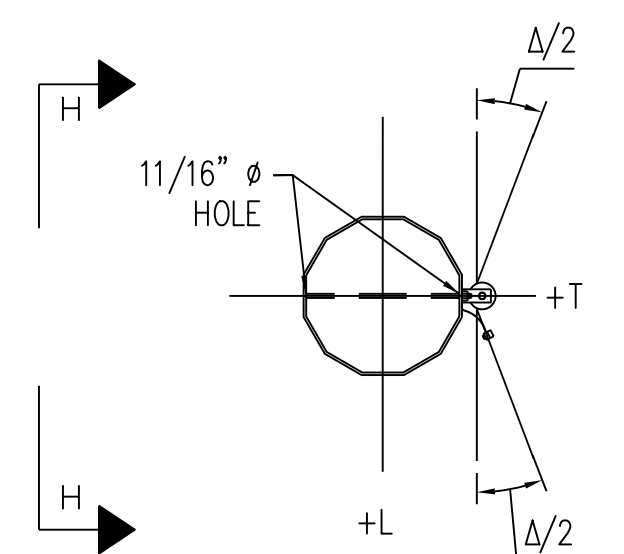

SECTION E-E (N.T.S.)
COMMUNICATIONS ATTACHMENT
"AT-XXX27DT-144-CLCB"
144 FIBER

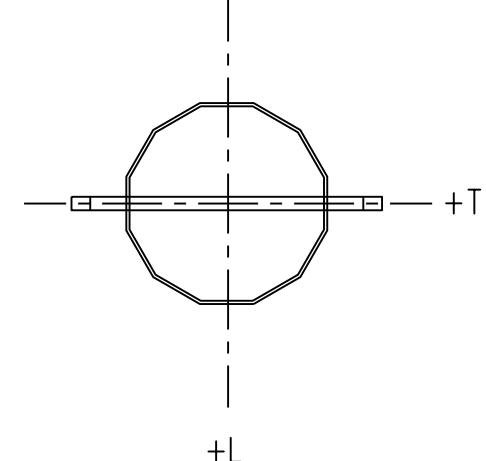

SECTION F-F (N.T.S.)
3RD PARTY COMMUNICATIONS
ATTACHMENT

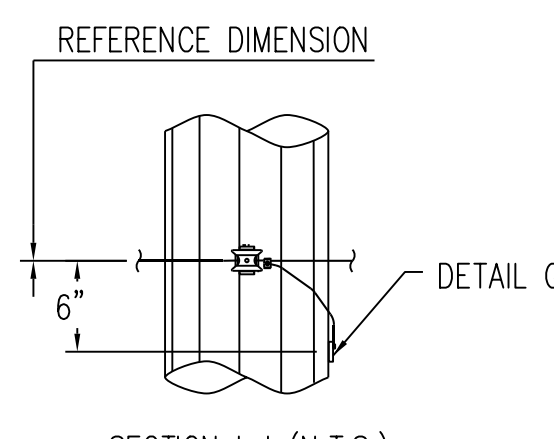

SECTION I-I (N.T.S.)
DISTRIBUTION NEUTRAL
1/0 6/1 STRAND
"RAVEN" ACSR

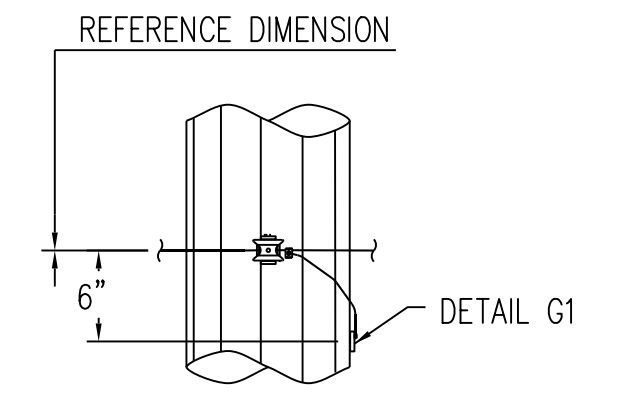

SECTION H-H (N.T.S.)
COMMUNICATIONS ATTACHMENT
"AT-XXX27DT-144-CLCB"
144 FIBER

STR #	HEIGHT (FT)	ANGLE Δ
143	85	7

LOAD	LOADING TABLE				
	CASE 1	CASE 2	CASE 3	CASE 7	CASE 9
V1	200	200	600	100	600
T1	1100	900	1200	200	1100
L1	-100	-100	-100	100	300
V2	900	500	1300	400	1400
T2	4300	3600	3400	1000	3100
L2	-100	-100	-100	100	200
V3	500	300	1000	300	1000
T3	3900	5800	2800	600	2300
L3	-100	-100	-100	100	1300
V4	400	200	900	200	900
T4	2000	1700	1800	400	1600
L4	-100	-100	-100	100	1000
V5	300	100	800	100	900
T5	900	1200	900	200	700
L5	-100	-100	-100	100	700
V6	500	200	1000	200	1100
T6	900	1600	1000	100	700
L6	-100	-100	-100	-	600
W[PSF]	10	36.9	4.1	0	0

ALL LOADS ARE IN LBS, ARE ULTIMATE, AND INCLUDE ALL OVERLOAD FACTORS. "W" REPRESENTS WIND PRESSURE (psf) TO BE APPLIED TO STRUCTURE.

LOAD CASES

- CASE 1 NESM MEDIUM: 15°, .25" ICE, 4 PSF WIND
OLF: L=1.65, T=2.50, V=1.50
- CASE 2 NESM HIGH WIND: 60°, 0" ICE, 120 MPH WIND
OLF: L=1.00, T=1.00, V=1.00
- CASE 3 NESM ICE WITH WIND: 15°, 1" ICE, 40 MPH WIND
OLF: L=1.00, T=1.00, V=1.00
- CASE 7 DEFLECTION: 60 DEGREES, NO ICE, NO WIND, FINAL
OLF: L=1.00, T=1.00, V=1.00
- CASE 9 UNBALANCED ICE: 32 DEGREES, 1" ICE, NO WIND
OLF: L=1.10, T=1.10, V=1.10

WIRE DATA

OHGW: "7#9" ALUMOWELD
115kV: 1272 KCMIL 61/0 STRAND "NARCISSUS" AAC
12.47kV: 336.4 KCMIL 18/1 STRAND "MERLIN" ACSR
DISTRIBUTION NEUTRAL: 1/0 6/1 STRAND "RAVEN" ACSR
ADSS: "AT-XXX27DT-144-CLCB" 144 FIBER

NOTES:

- ALL STATED LOADS ARE ULTIMATE VALUES AND INCLUDE OVERLOAD FACTORS AND INSULATOR WEIGHT.
- STRUCTURE AND ATTACHMENTS SHALL BE DESIGNED FOR THE SIMULTANEOUS APPLICATION OF DEAD LOAD, WIND ON THE STRUCTURE, AND WIRE LOADS FOR EACH LOADING CASE.
- STRUCTURE SHALL BE DESIGNED SELF SUPPORTING. GUYS ARE NOT PERMITTED. STRUCTURE SHALL MEET ALL TECHNICAL REQUIREMENTS OF THE STEEL POLE SPECIFICATIONS.
- WIND PRESSURES SHOWN ON LOAD WORKSHEET ARE BASED ON A SHAPE FACTOR OF 1.0.
- FABRICATOR MAY PROPOSE STRUCTURAL DETAILS DIFFERENT THAN THOSE SHOWN TO SIMPLIFY FABRICATION. VARIATIONS SHALL BE SUBMITTED TO ENGINEER IN WRITING.
- MINIMUM VANG PLATE THICKNESS = 1/2".
- WIND SHALL BE APPLIED IN THE DIRECTION WHICH RESULTS IN THE MOST SEVERE EFFECT.
- THE DEFLECTION AT THE POLE TOP SHALL BE LIMITED TO 1.5% OF THE POLE HEIGHT UNDER THE DEFLECTION CASE. POLES MAY BE CAMBERED TO FALL WITHIN THE DESIGN LIMIT.
- MAXIMUM DEFLECTION AT TOP OF THE STRUCTURE SHALL BE LIMITED TO 10% OF STRUCTURE HEIGHT UNDER ALL LOAD CASES WITH THE EXCEPTION TO THE 60° NO WIND LOAD CASE.
- POLE DESIGN AND FABRICATION SHALL INCLUDE PROVISIONS FOR A SLIP JOINT TO LIMIT LOWEST POLE SEGMENT EXTENSION ABOVE GRADE TO 12'-0" MAXIMUM.
- ALL STRUCTURES SHALL BE GALVANIZED STEEL.
- ORIENT SINGLE SIDED VANGS FOR HARDWARE SHOWN ON DRAWINGS.
- MANUFACTURER SHALL APPLY POINT LOADS NECESSARY TO CREATE THE MOST SEVERE EFFECTS ON ALL MEMBERS INCLUDING ARMS, POLES, BASE PLATES, ETC.

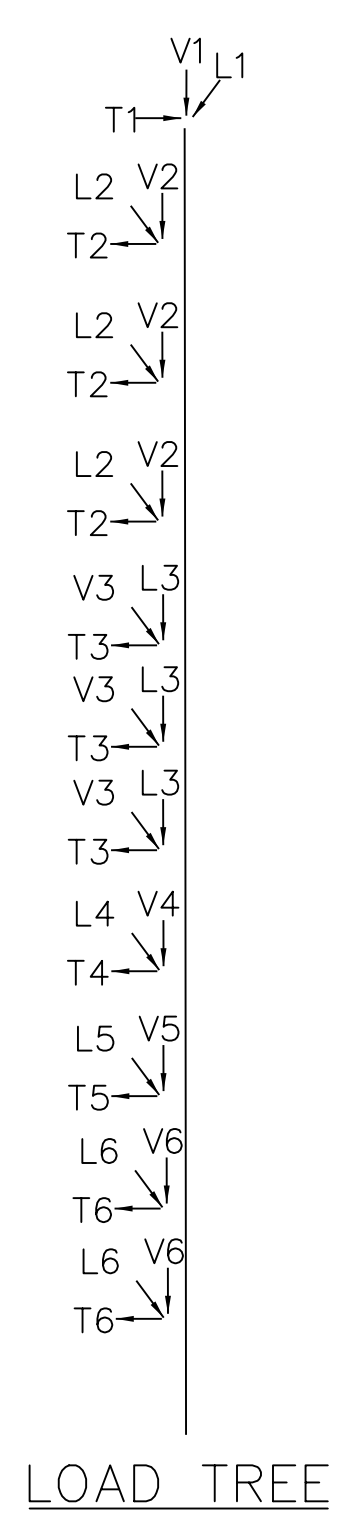

LOAD TREE

NO.	REVISIONS
A	MT. PLEASANT TO SUGG T-LINE ISSUED FOR BID ENGINEER'S: S.E DATE: 12/03/21

CONSTRUCTION NOTE:
REMOVE OLD WIRE LABELS WITH ORANGE TEXT,
INSTALL NEW WIRE LABELS WITH GREEN TEXT

ISSUED FOR BID

GREENVILLE UTILITIES
Greenville, North Carolina

115kV TRANSMISSION LINE
MT. PLEASANT SUB TO SUGG
LOAD AND DESIGN
RUNNING ANGLE 10° WITH UNDERBUILD

DWIND. CHAMBLISS DATE 12/03/21 DWG. NO.
CKD. R. DILLABOUGH APPD. S. ECKMAN RA-15R_Vert_1-CT
SCALE: NONE

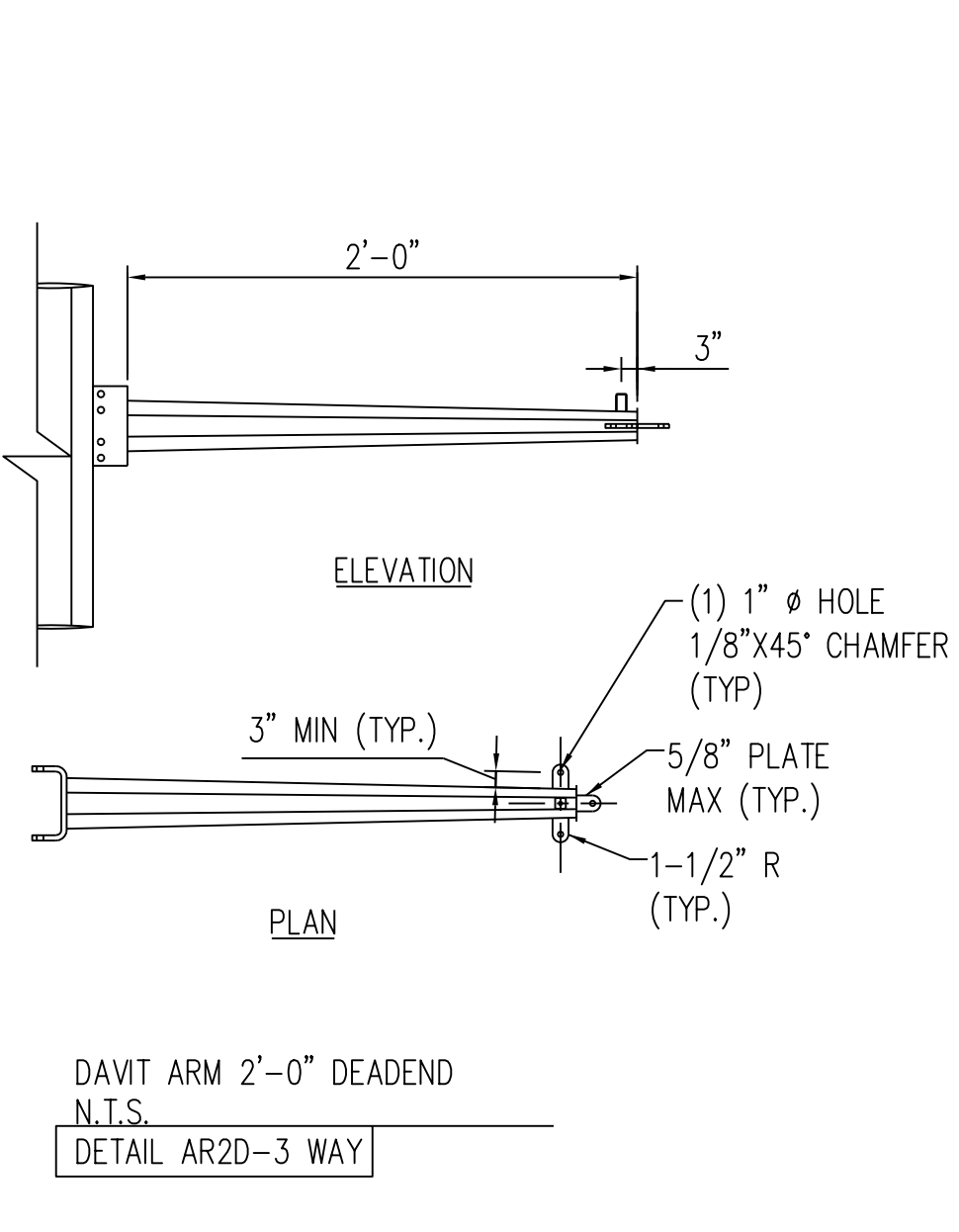
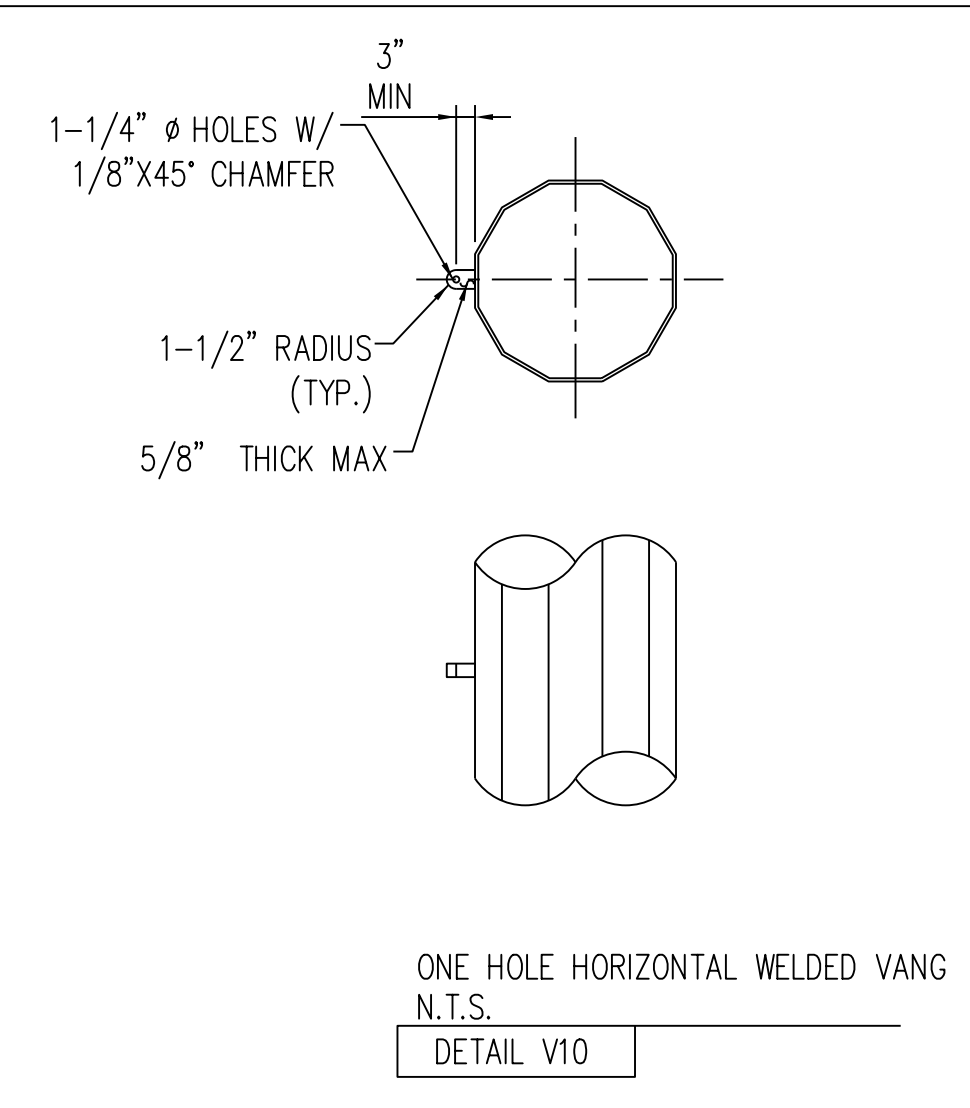
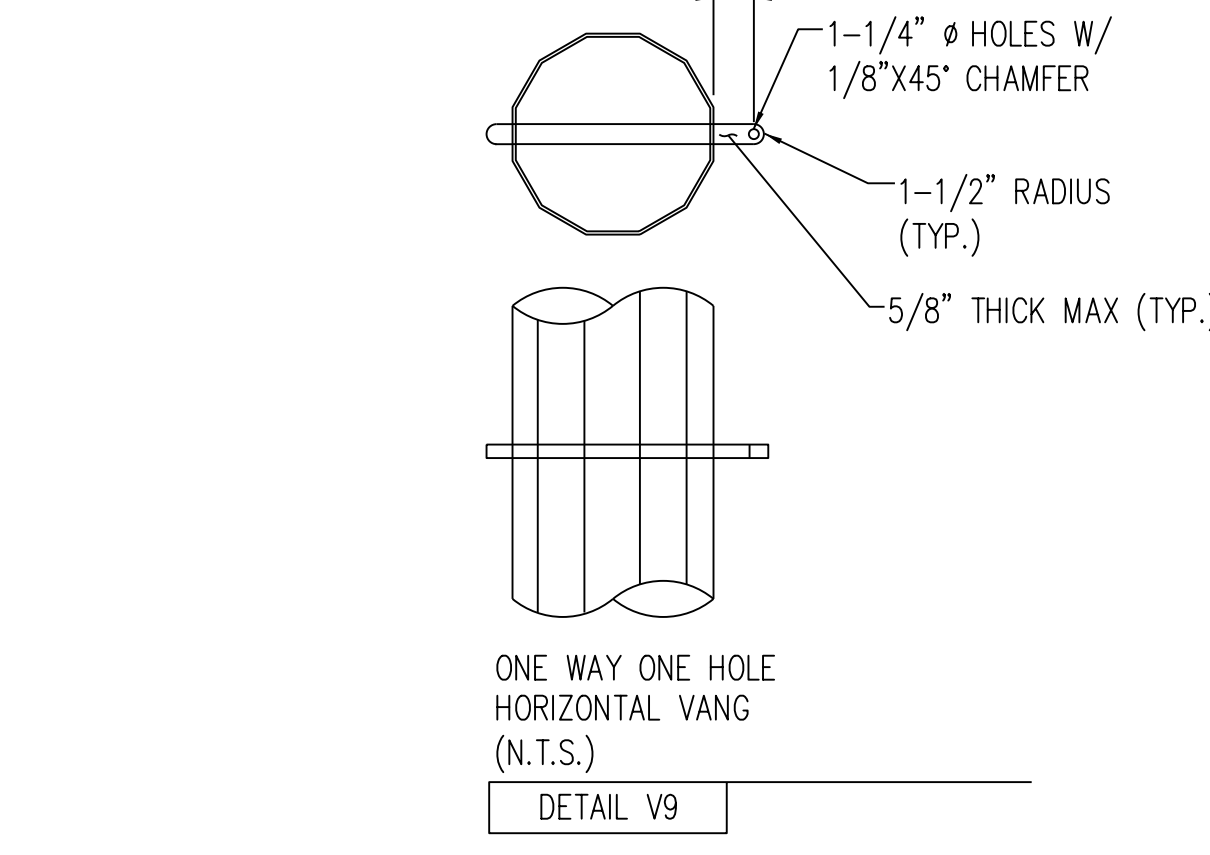
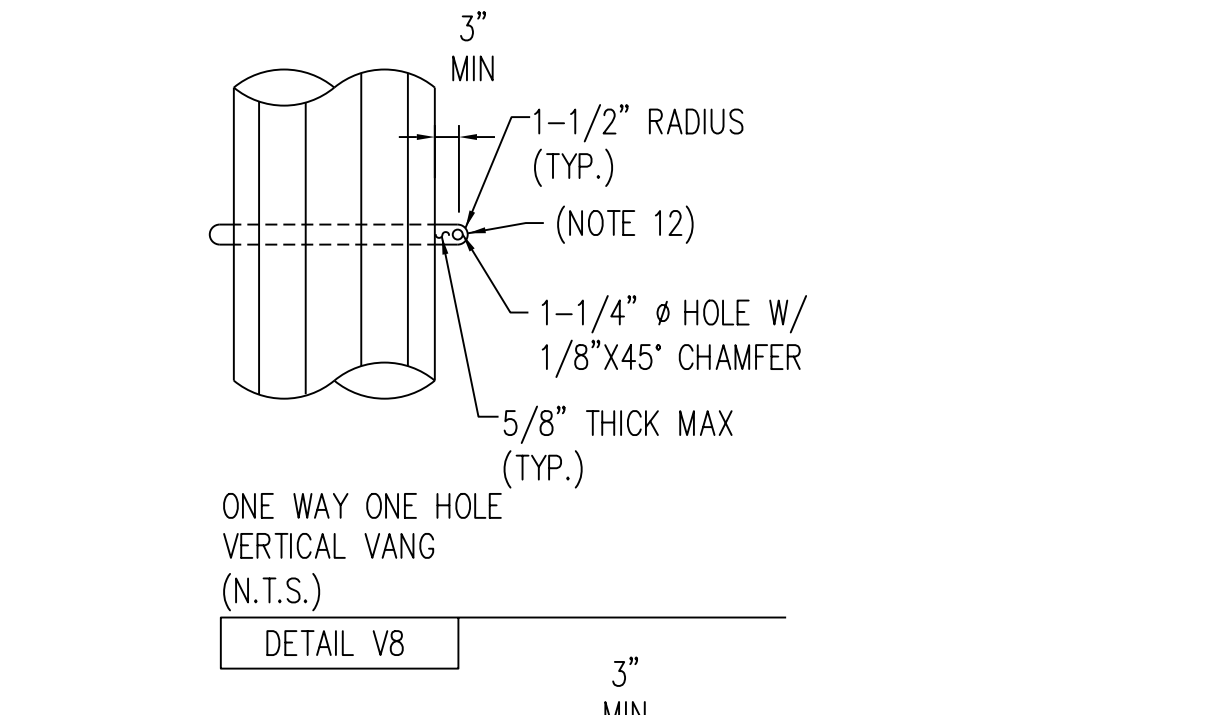
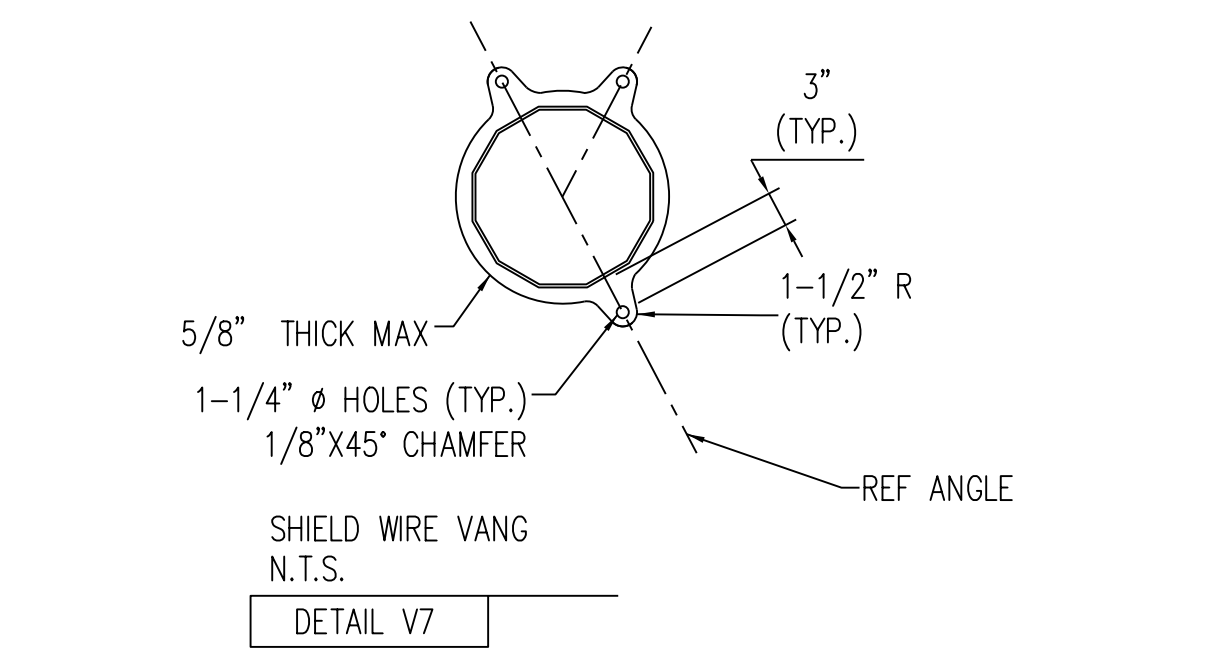
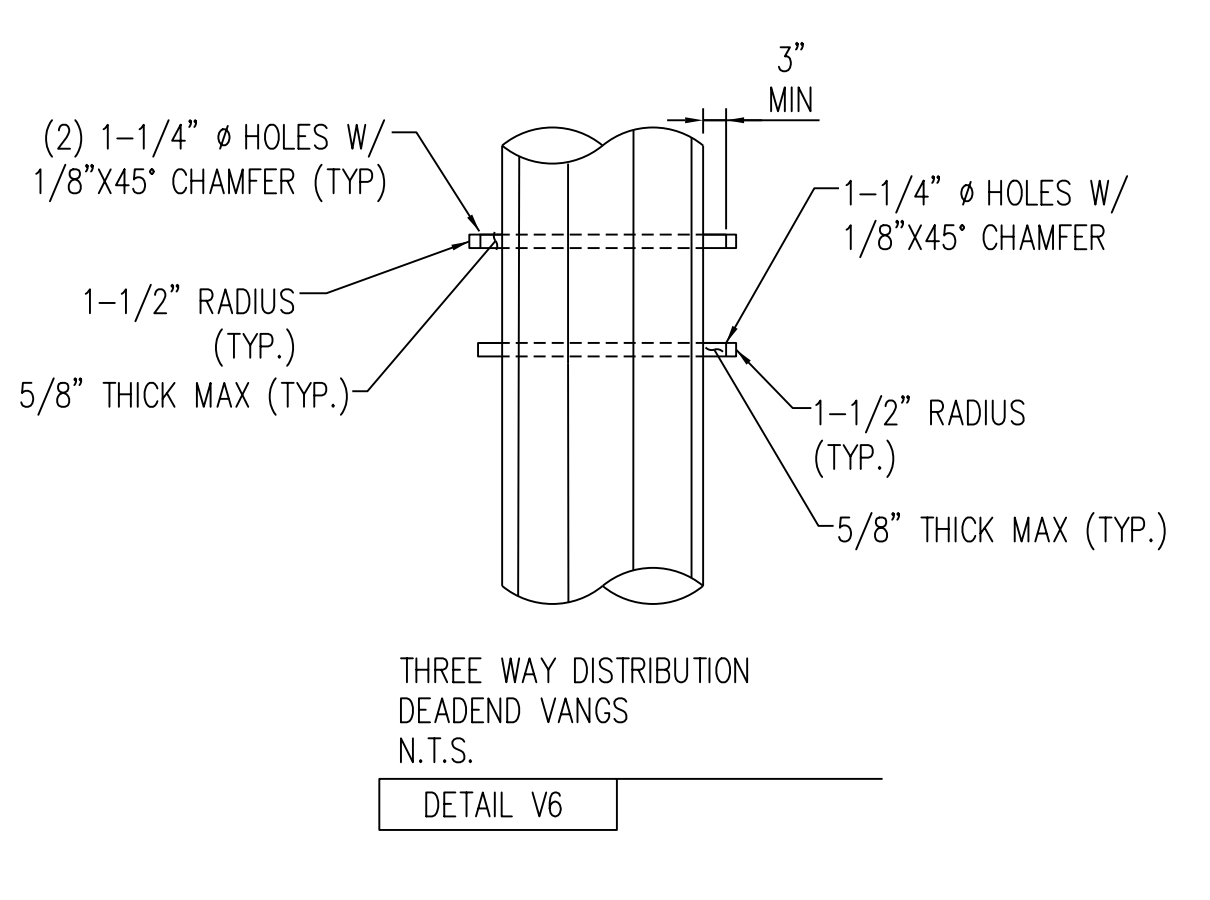
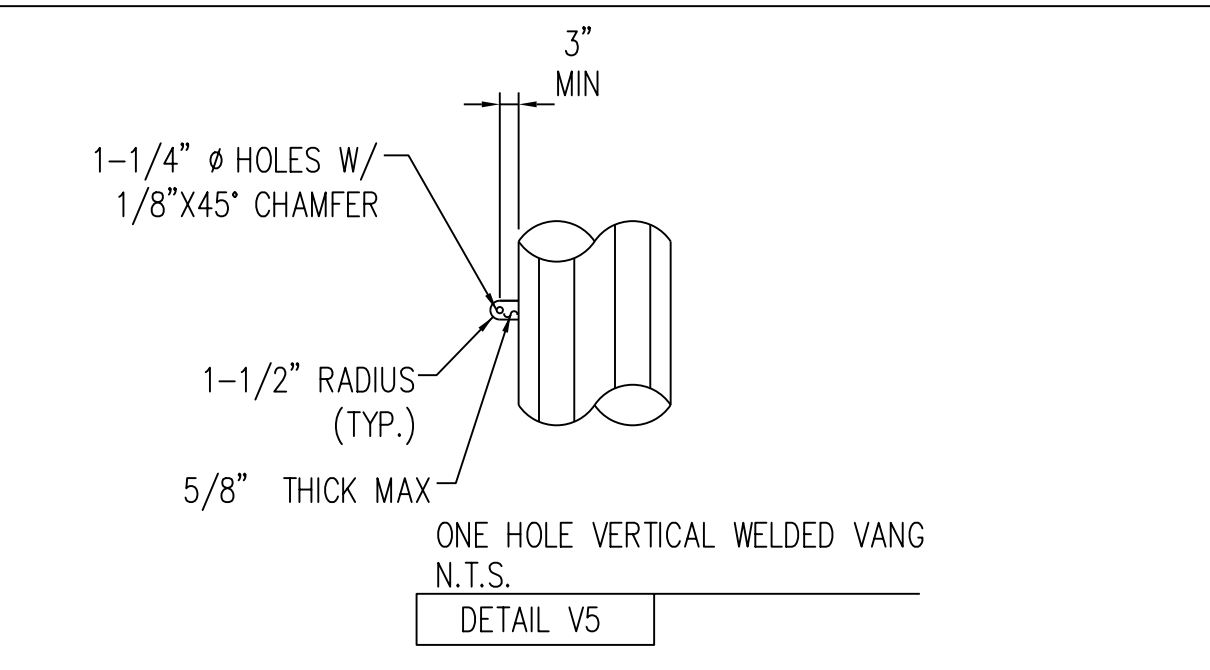
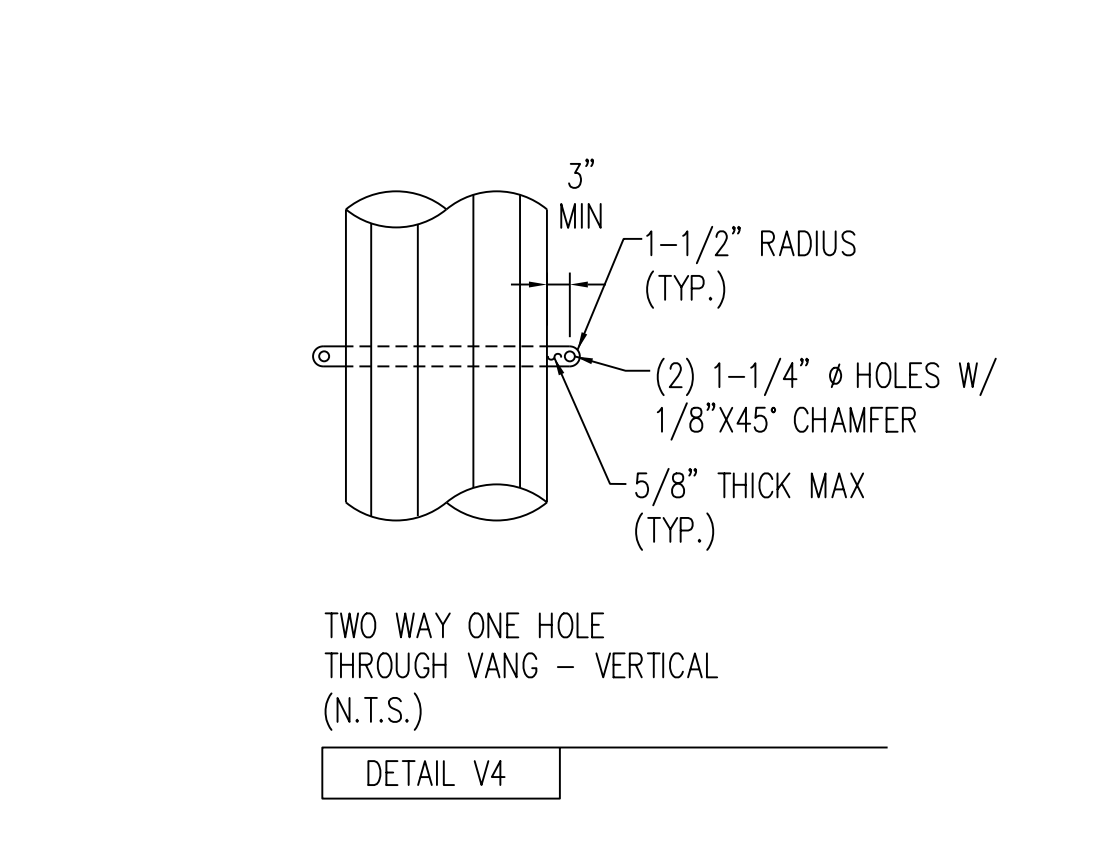
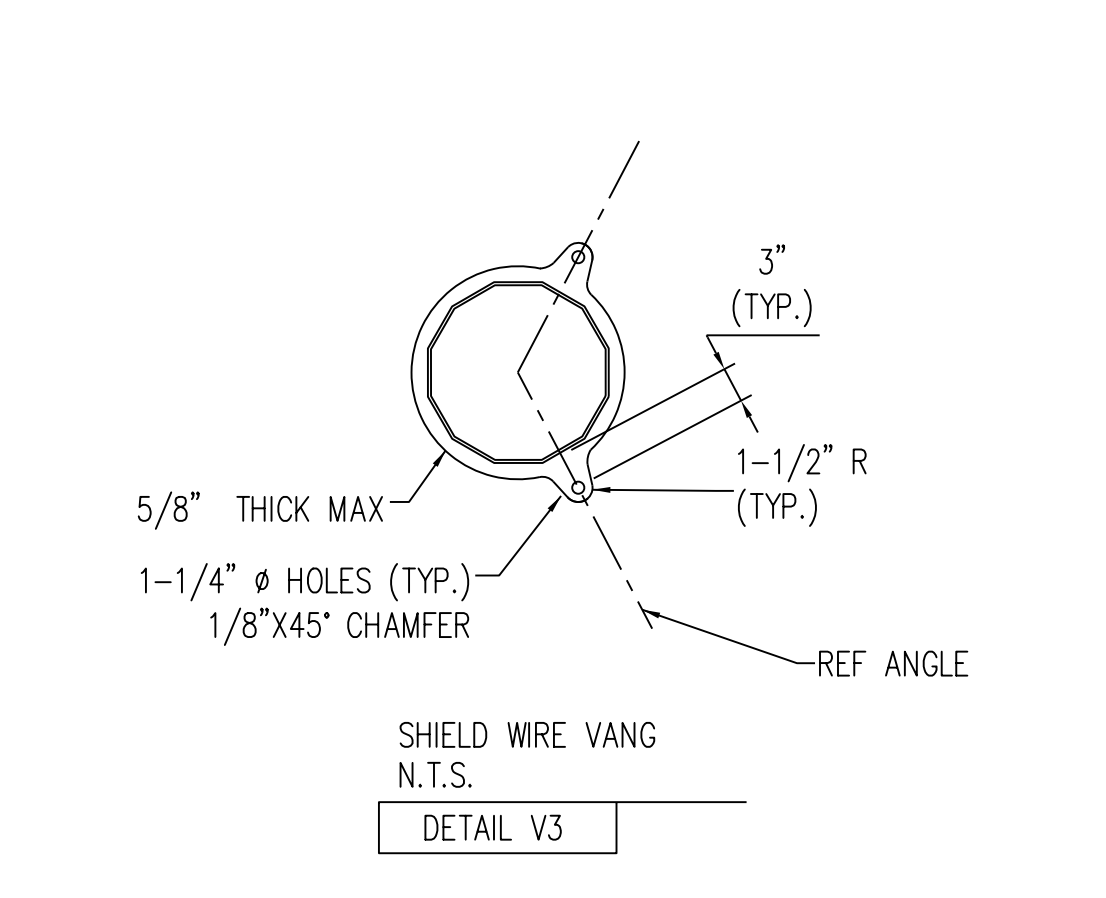
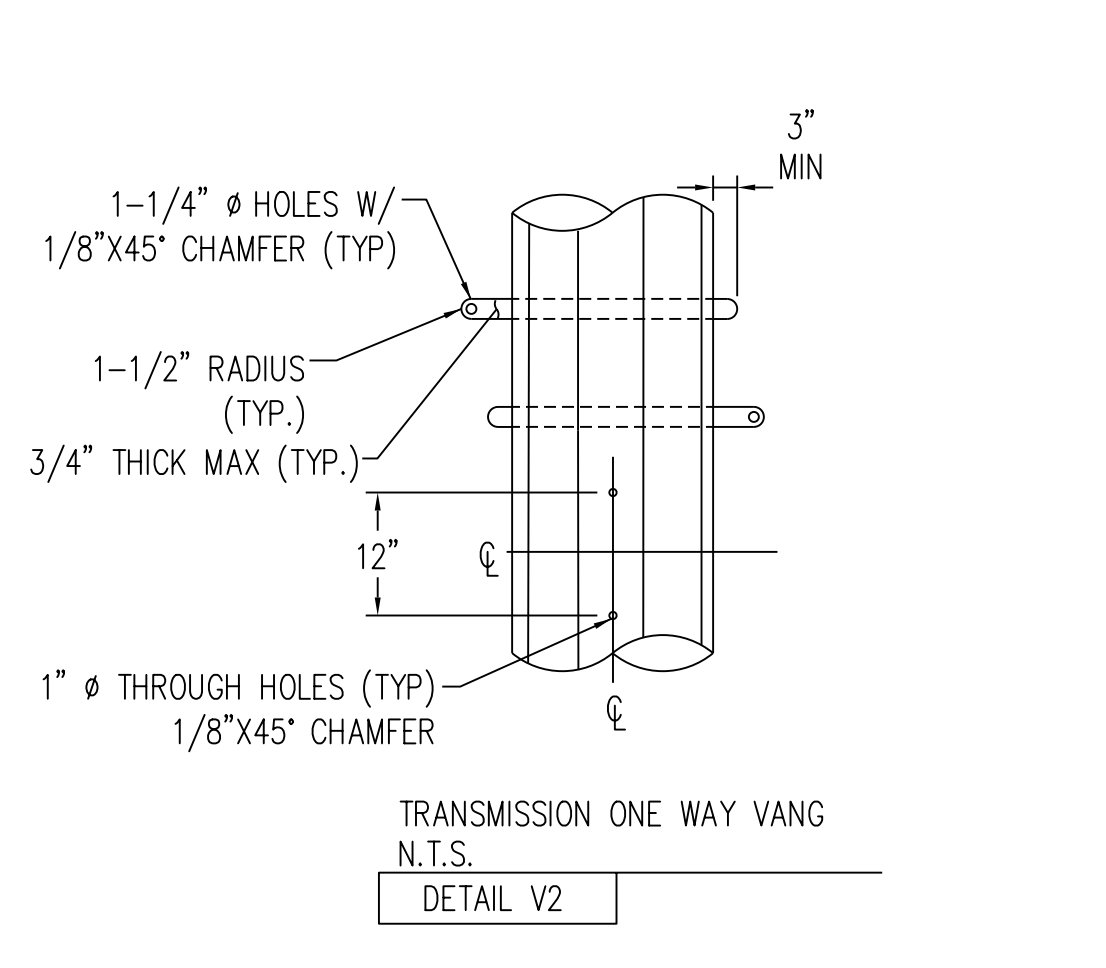
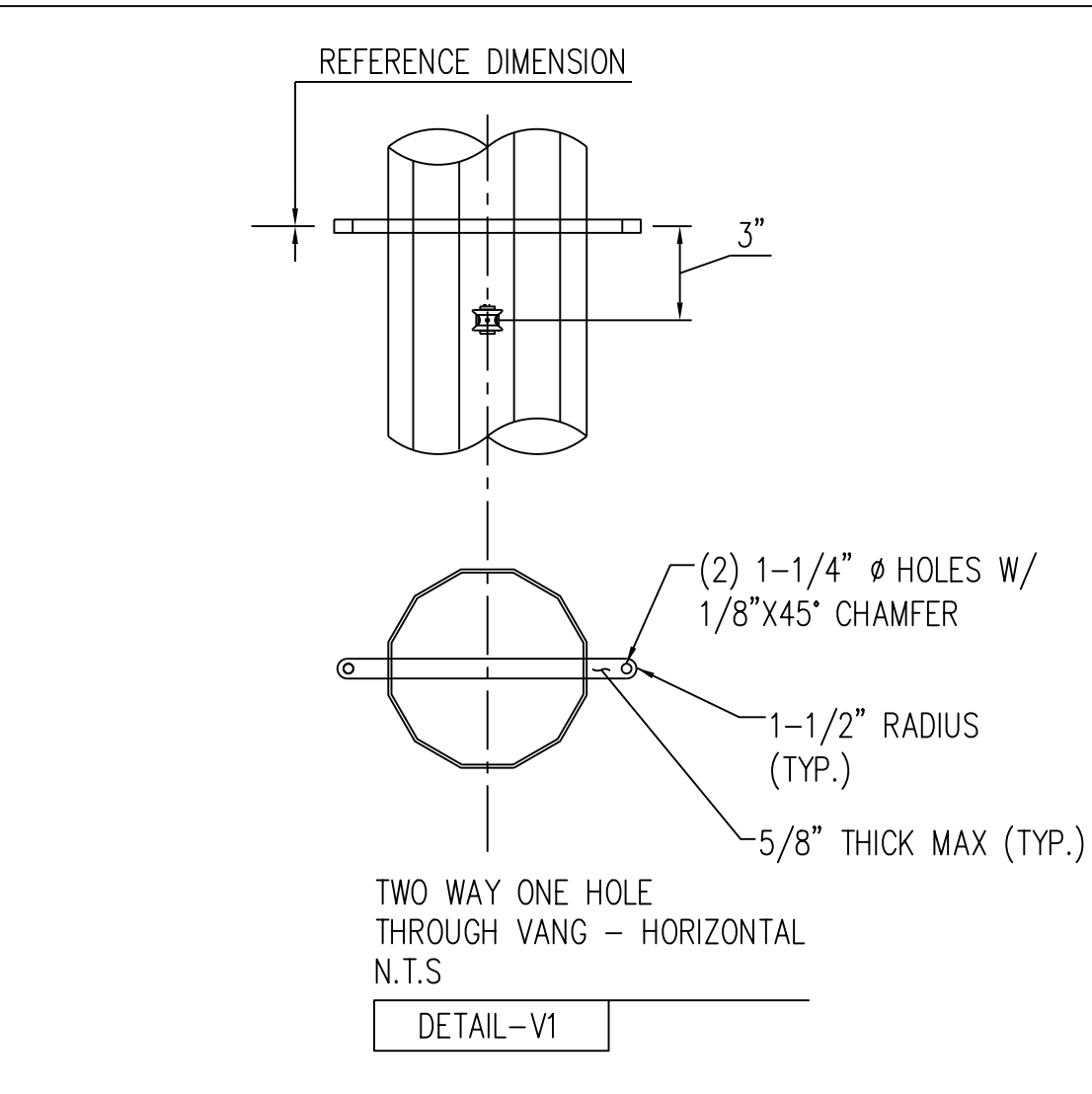
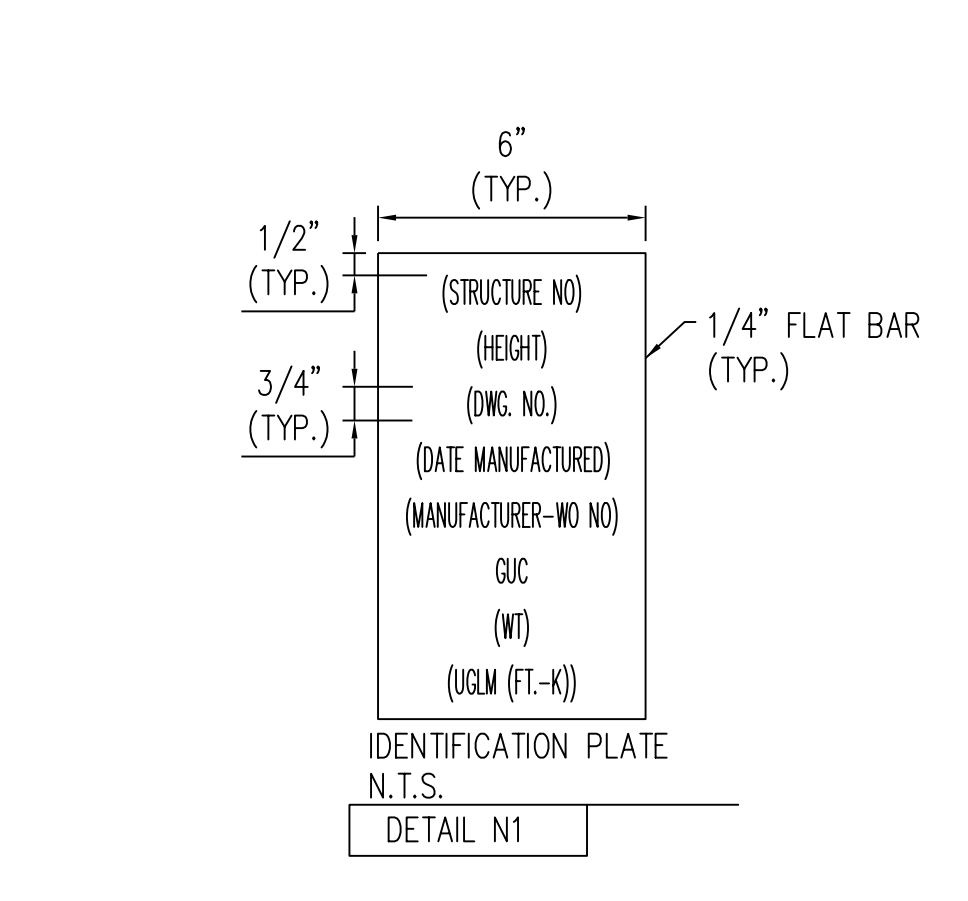
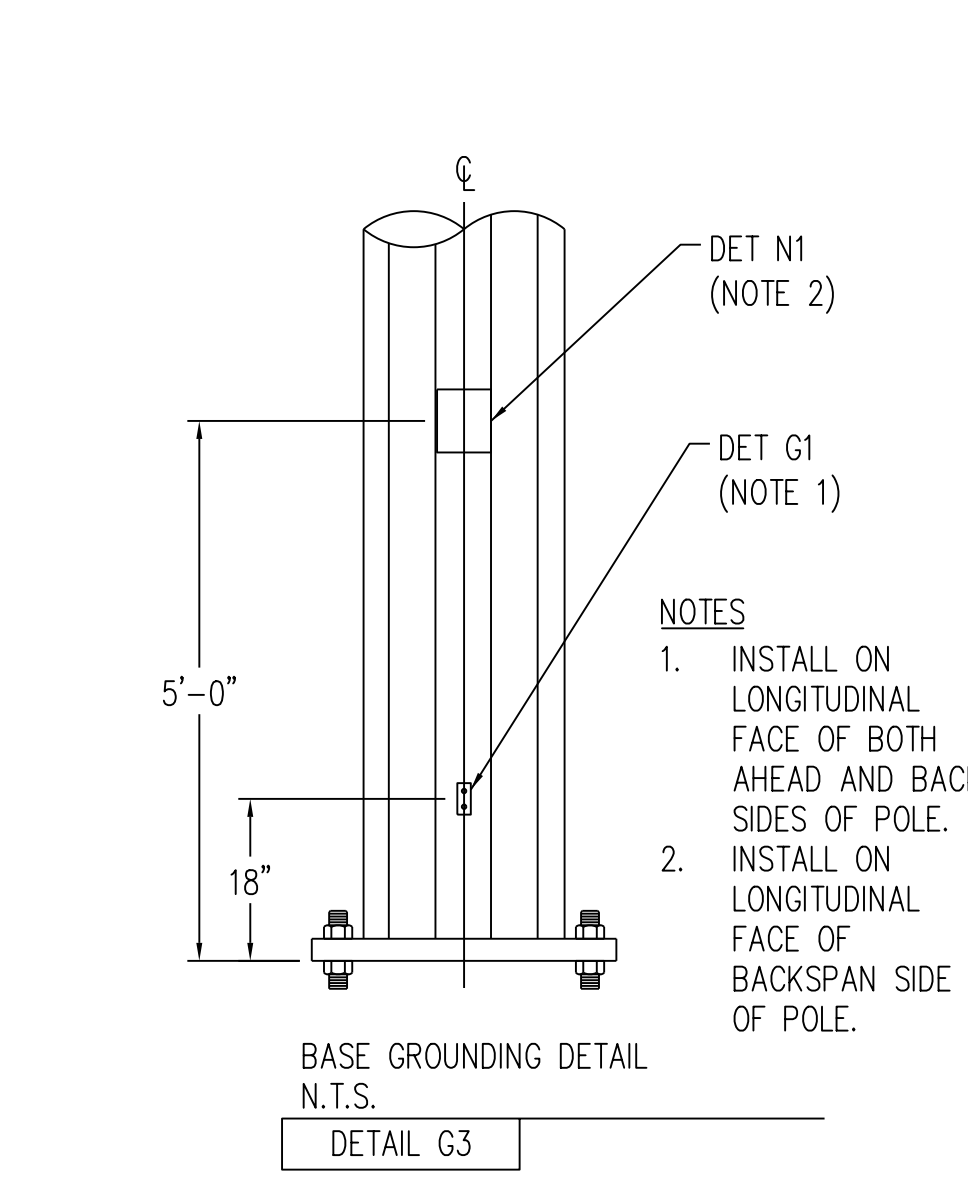
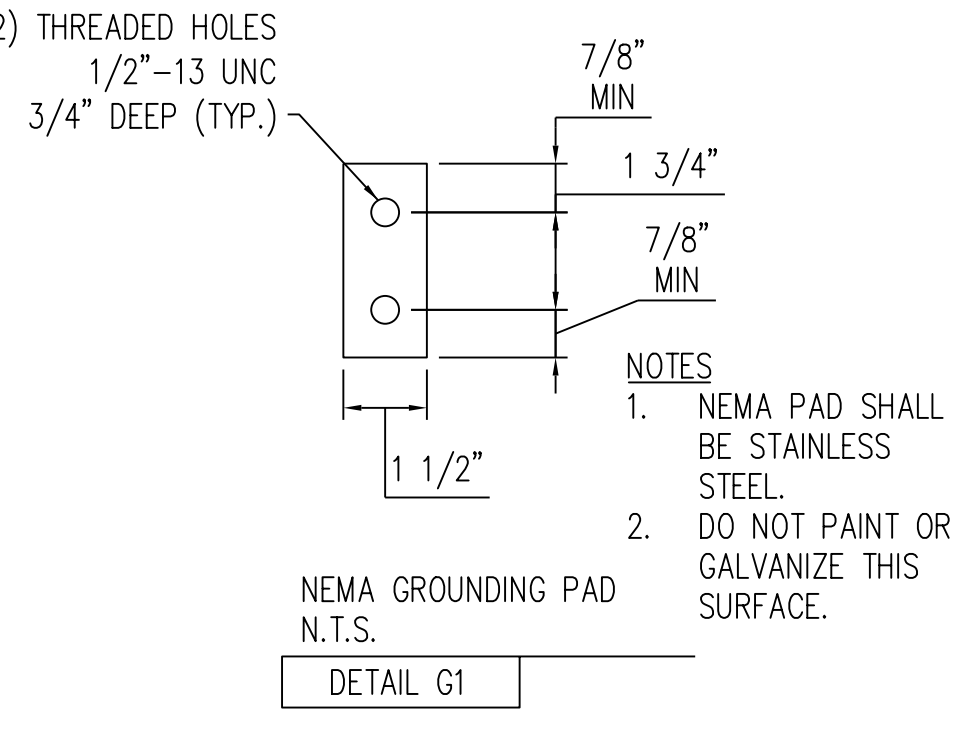
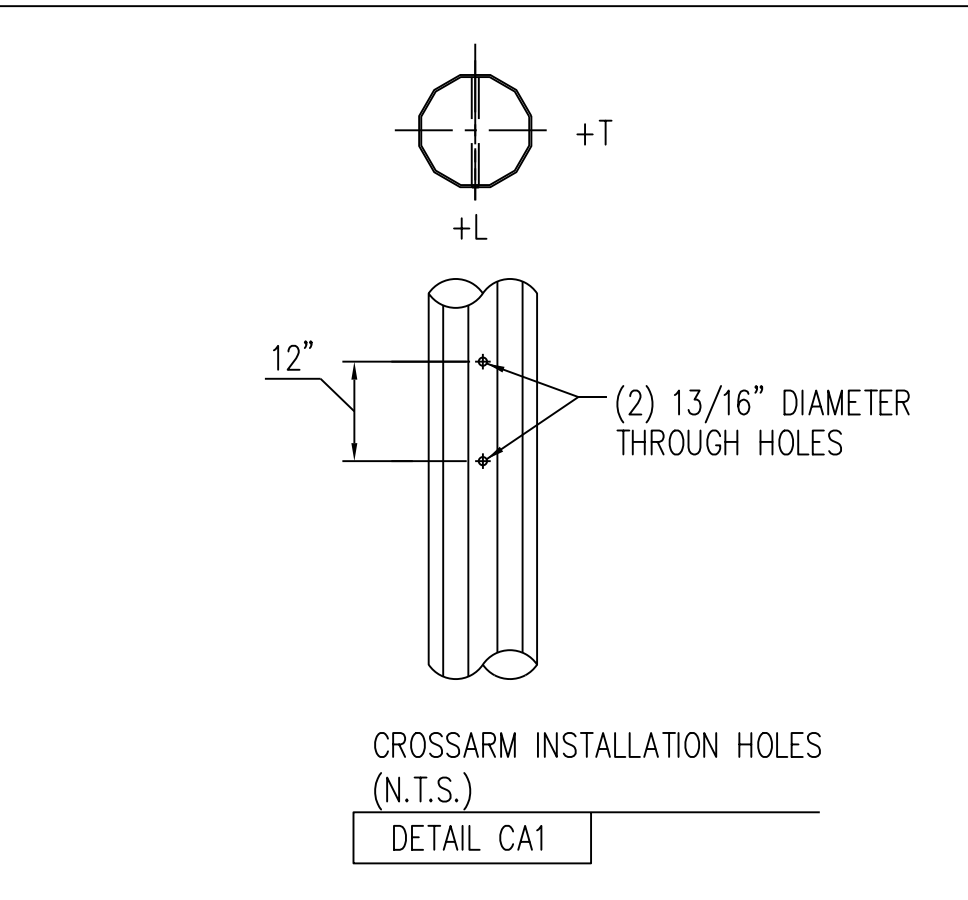
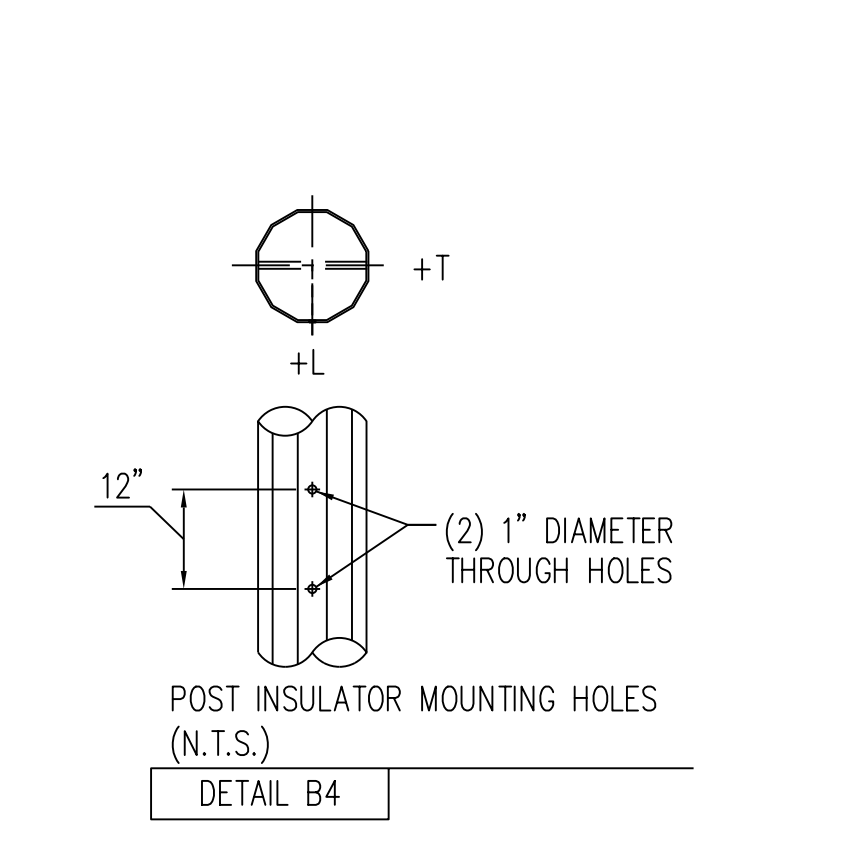
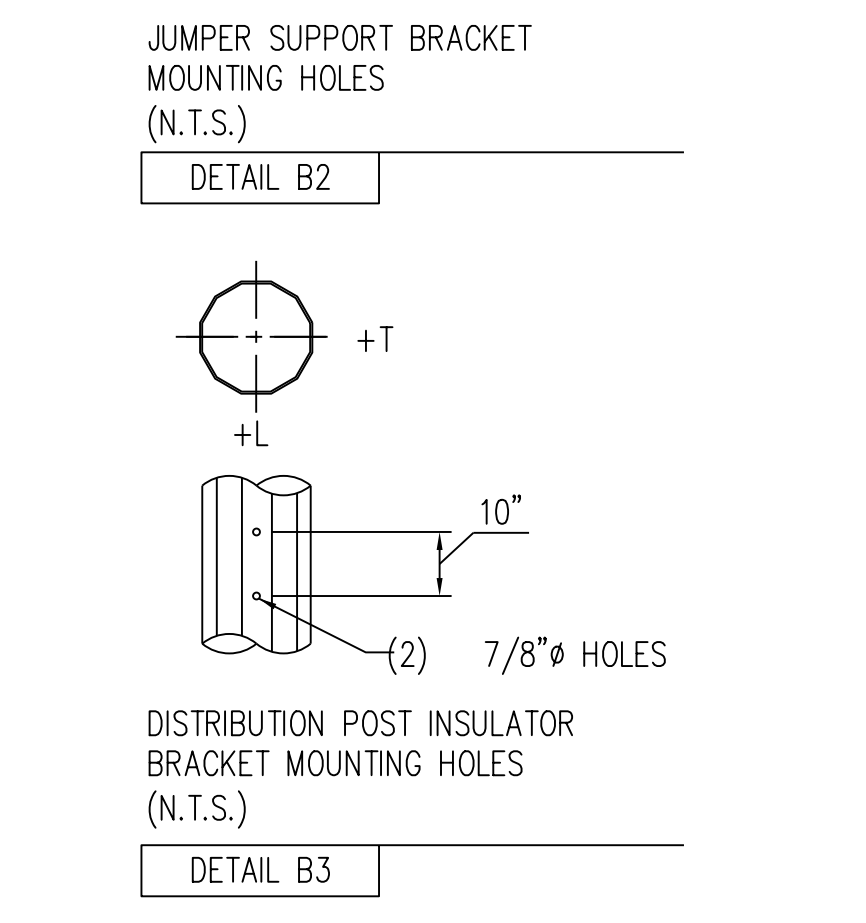
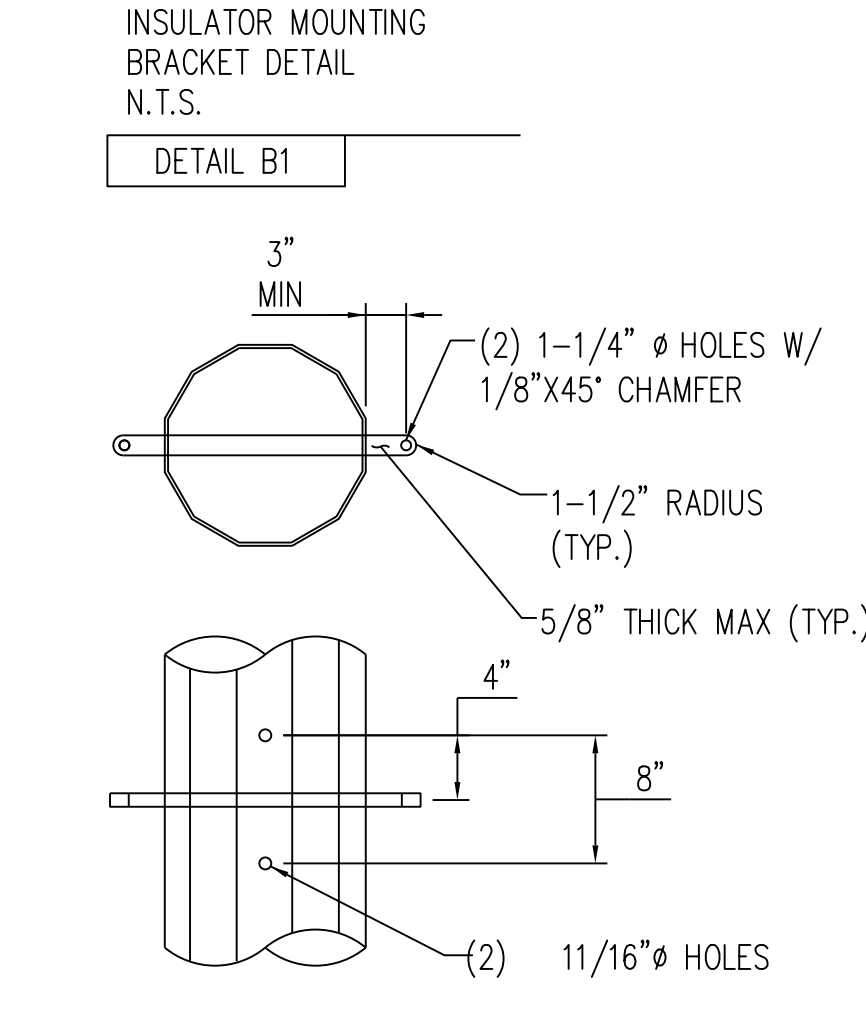
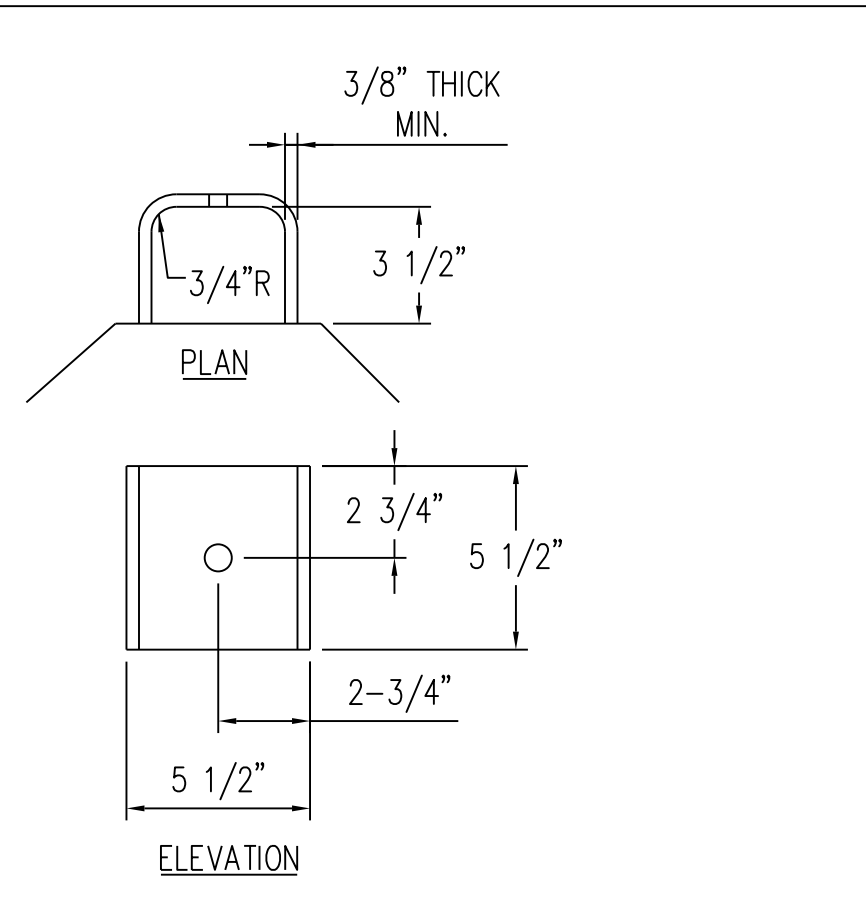
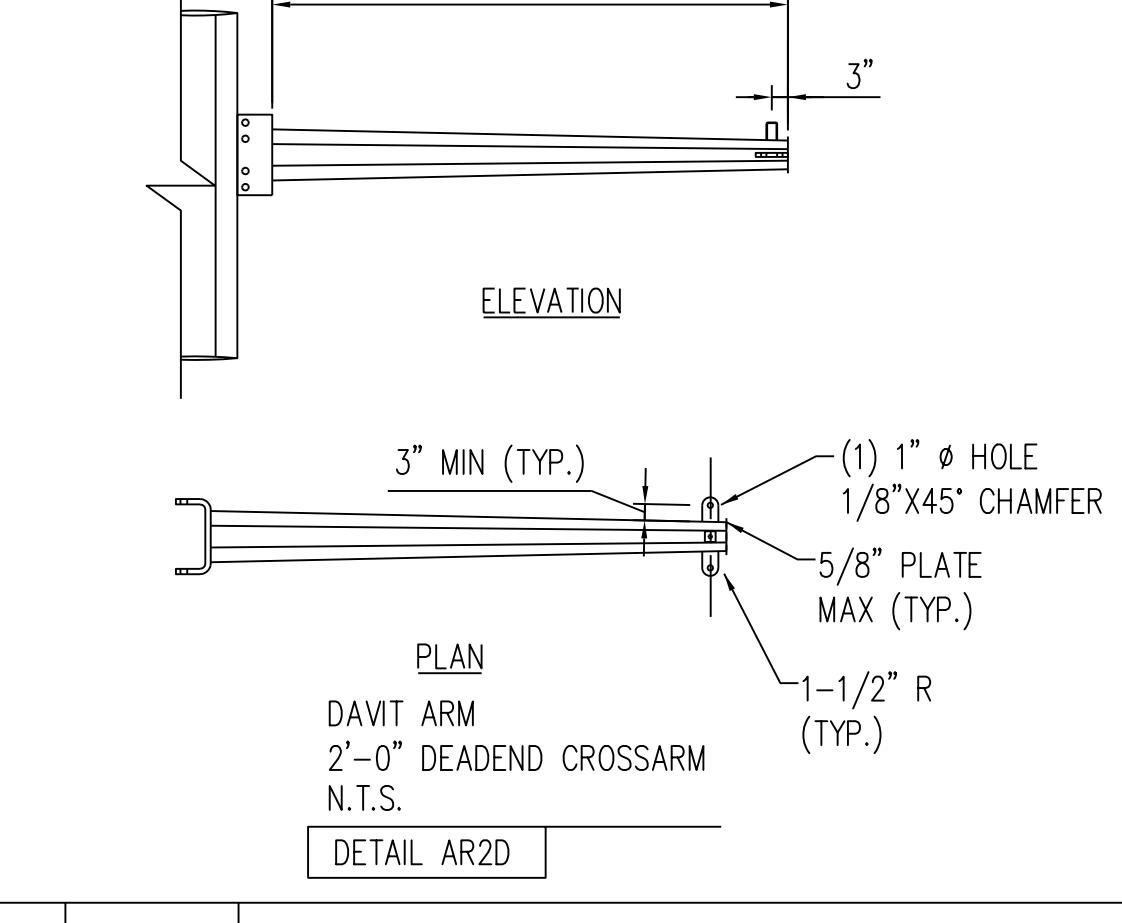
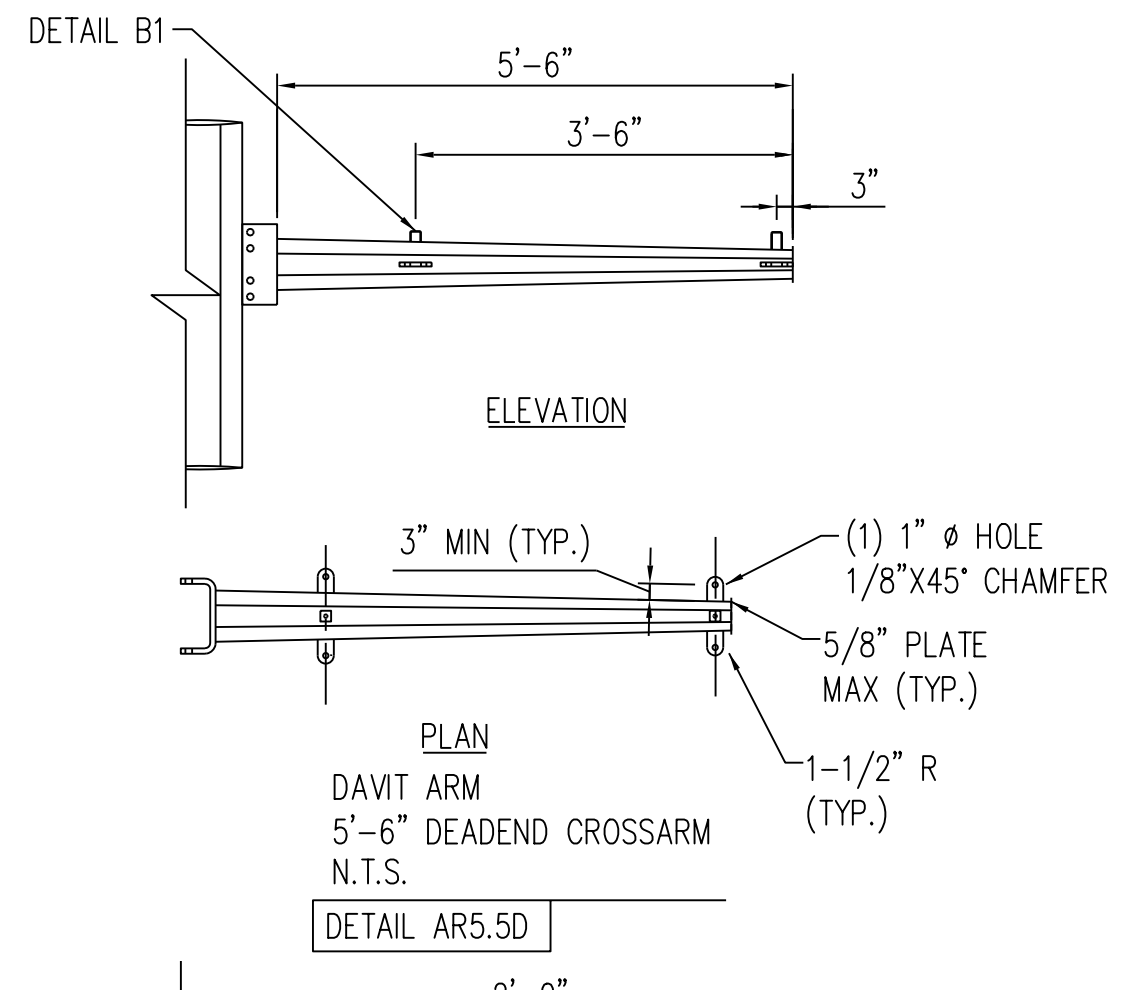
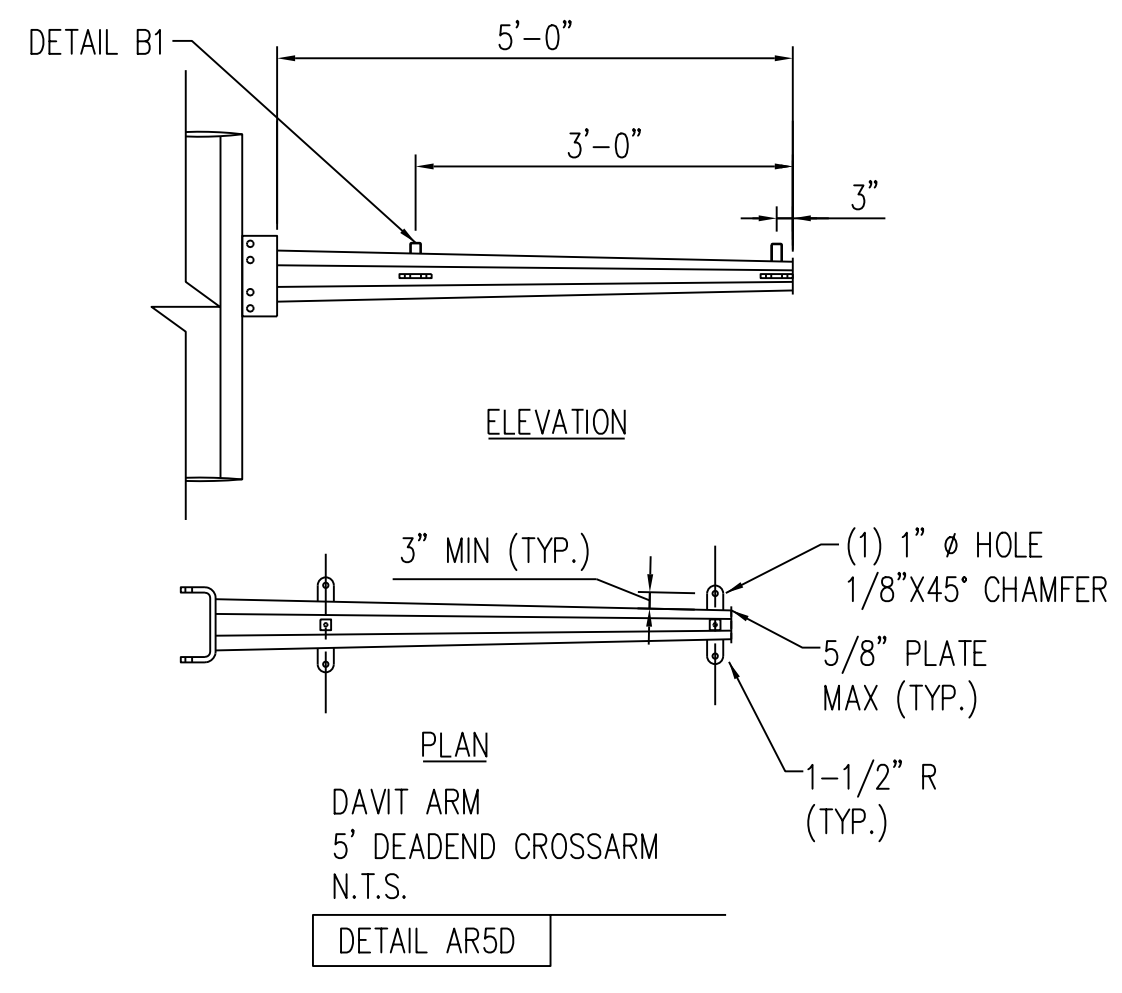
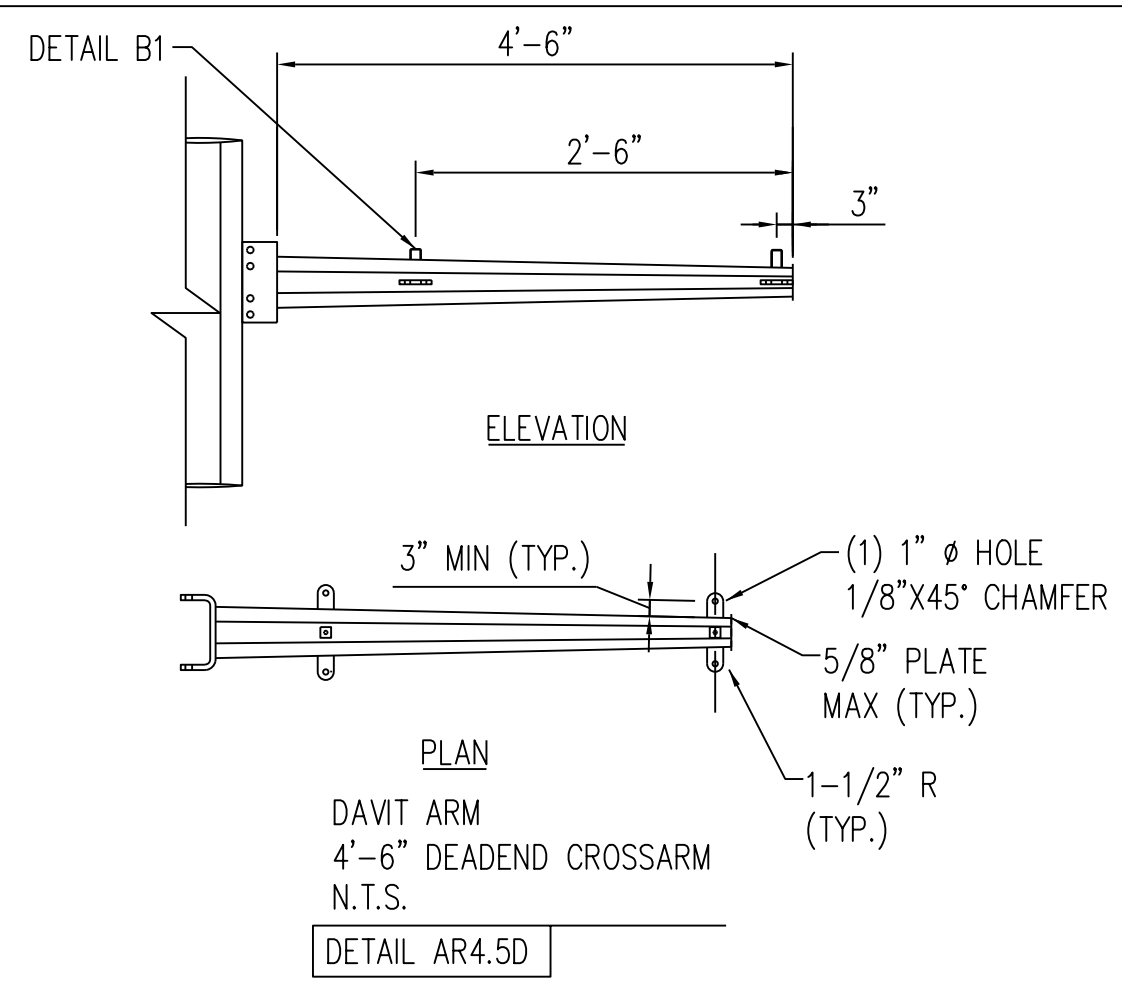

NO.	A
REVISIONS	
MT. PLEASANT TO SUGG T-LINE ISSUED FOR BID ENGINEERS: S.E DATE: 12/03/21	

CONSTRUCTION NOTE:
REMOVE OLD WIRE LABELS WITH ORANGE TEXT,
INSTALL NEW WIRE LABELS WITH GREEN TEXT

ISSUED FOR BID

GREENVILLE UTILITIES
Greenville, North Carolina

115kV TRANSMISSION LINE
MT. PLEASANT SUB TO SUGG
DETAILS

DWN.D. CHAMBLISS DATE 12/03/21
CKD. R. DILLABOUGH APPD. S. ECKMAN
SCALE: NONE

DWG. NO.
DETAILS

Attachment C. Structure Weights and Costs

Wood Pole Equivalent Structures						
STR Class	STR Height	Total	Structure Weight (lb)	Structure Cost	Total Structure Weight (lb)	Total Structure Cost
H4	70	4	-	\$		\$
	75	-	-	\$		\$
	80	-	-	\$		\$
	85	-	-	\$		\$
	90	-	-	\$		\$
	95	-	-	\$		\$
H5	70	2	-	\$		\$
	75	-	-	\$		\$
	80	-	-	\$		\$
	85	-	-	\$		\$
	90	-	-	\$		\$
	95	-	-	\$		\$
H6	70	13	-	\$		\$
	75	4	-	\$		\$
	80	11	-	\$		\$
	85	2	-	\$		\$
	90	-	-	\$		\$
	95	-	-	\$		\$
H7	70	3	-	\$		\$
	75	5	-	\$		\$
	80	3	-	\$		\$
	85	7	-	\$		\$
	90	-	-	\$		\$
	95	-	-	\$		\$
H8	70	2	-	\$		\$
	75	9	-	\$		\$
	80	6	-	\$		\$
	85	7	-	\$		\$
	90	-	-	\$		\$
	95	-	-	\$		\$
H9	70	1	-	\$		\$
	75	1	-	\$		\$
	80	5	-	\$		\$
	85	1	-	\$		\$
	90	-	-	\$		\$
	95	-	-	\$		\$
H10+	70	1	-	\$		\$
	75	4	-	\$		\$
	80	16	-	\$		\$
	85	6	-	\$		\$
	90	5	-	\$		\$
	95	3	-	\$		\$
					Total Cost	\$ -

Engineered Structures			
STR #	STR Height	Structure Weight (lb)	Total Structure Cost
1	80		\$
3	85		\$
4	90		\$
5	95		\$
6	80		\$
11	75		\$
13	75		\$
18	80		\$
21	90		\$
22	100		\$
23	95		\$
25	70		\$
35	80		\$
38	75		\$
40	75		\$
42	85		\$
45	75		\$
46	80		\$
49	85		\$
50	80		\$
52	95		\$
61	90		\$
62	105		\$
63	105		\$
64	75		\$
65	75		\$
99	85		\$
100	80		\$
101	80		\$
102	80		\$
114	90		\$
115	90		\$
132	75		\$
140	80		\$
141	80		\$
142	80		\$
143	85		\$
145	80		\$
147	75		\$
151	80		\$
153	85		\$
154	95		\$
		Total Cost	\$ -

Attachment D, Bid Summary-Design Information, and Weights

POLE DESIGN										
DESCRIPTION		STRUCTURE HEIGHT								
DIAMETER TAPER (IN/FT), 1ST SECT.										
DIAMETER TAPER (IN/FT), 2ND SECT.										
BOTTOM DIAMETER										
TOP DIAMETER										
CROSS SECTION TYPE										
MATERIAL THICKNESS (IN),1ST SEC										
MATERIAL THICKNESS (IN),2ND SEC										
ASTM	MATERIAL									
	GRADE									
GOVERNING LOAD CASE(S)										
MAX. MOMENT AT GROUNDLINE										
MAX. SHEAR AT GROUNDLINE										
MAX. AXIAL LOAD AT GROUNDLINE										
MAX. LOAD IN GUY										
ANCHOR BOLTS	SIZE/SPACING									
	LENGTH									
	CAGE DIAMETER									
ARM DESIGN										
DESCRIPTION		ARM TYPE AND DATA								
		A	B	C	D	E	F			OHW
TAPER (IN/FT)										
END DIAMETER (IN)										
DIAMETER AT POLE (IN)										
CROSS SECTION TYPE										
ASTM	MATERIAL									
	GRADE									
GOVERNING LOAD CASE(S)										
MOMENT AT THE POLE (KIP-FT)										
GOVERNING LOAD CASE(S)										
MOMENT AT THE POLE (KIP-FT)										
SUMMARY										
ITEMS		STRUCTURE HEIGHTS								
WEIGHT OF ARMS (TOTAL)										
WEIGHT OF POLE										
WEIGHT OF ANCHOR BOLTS										
TOTAL WEIGHT PER STRUCTURE										
TOTAL COST PER STRUCTURE										
NUMBER OF STRUCTURES										
TOTAL WEIGHTS										
TOTAL COSTS										
COMMENTS						TRANSMISSION LINE STRUCTURE				
						ATTACHMENT E				
						BID SUMMARY - DESIGN, WEIGHTS, AND COSTS				
						(information to be supplied with proposal)				

SUBMIT BIDS ON ATTACHED PROPOSAL FORM

SPECIFICATIONS FOR TUBULAR STEEL STRUCTURES

In the space below, please provide a price quote for the following Tubular Steel Structures per the attached specifications. If your firm is unable to furnish this Tubular Steel Structures in accordance with our specifications and you wish to offer a substitute, please provide us with full details of the approved equivalent.

Item No.	Estimated Quantity	Description	Delivery Time	Unit Price	Extension
I	163	Tubular Steel Structures	_____	\$_____	\$_____

Method of Award: Items I will be awarded as a total bid.

Complete and Check All Math: It is the responsibility of the Bidder to extend bid prices and supply a total for all items. It is certified that this proposal is made in good faith and without collusion or connection with any other person bidding on the same above listed items. It is also certified that this proposal is made in good faith and without collusion or connection with any GUC employee(s).

The Undersigned Bidder: hereby declares that it has carefully examined the enclosed detailed specifications for furnishing GUC with the below listed items. The undersigned bidder further agrees, if this proposal is accepted within thirty (30) days from the date of the opening, to furnish any or all of the items upon the quoted price.

[Balance of page left blank intentionally]

It is certified that this proposal is made in good faith and without collusion or connection with any other person bidding on the same above listed items. It is also certified that this proposal is made in good faith and without collusion or connection with any GUC employee(s).

Each Proposal shall be accompanied by cash, cashier's check, or certified check drawn on a bank insured with the Federal Deposit Insurance Corporation or the Savings Association Insurance Fund, payable to the Owner, in an amount not less than five percent (5%) of the total bid as a guarantee that a Purchase Order, if awarded, will be accepted. In lieu thereof, a Bid Bond may be submitted by the Bidder in an amount not less than five percent (5%) of the total bid (see attached Bid Bond form). The total bid price for which the five percent (5%) applies shall be the total of all schedules.

Certified check or cash for \$ _____ or bid bond for \$ _____ attached.

Firm Name _____ Phone (_____) _____

Address _____

City _____ State _____ Zip Code _____

Fax (____) _____ E-Mail _____

Authorized Official _____ Title _____
Typed Name

Signature Date _____

BID BOND

KNOW ALL MEN BY THESE PRESENT, THAT WE _____

_____ as Principal, and _____

as Surety, who is duly licensed to act as Surety in North Carolina, are held and firmly bound unto the Greenville Utilities Commission of Greenville, North Carolina, as Obligee, in the penal sum of _____ DOLLARS (\$ _____) (5% Bid Bond), lawful money of the United States of America, for the payment of which, well and truly to be made, we bind ourselves, our heirs, executors, administrators, successors and assigns, jointly and severally, firmly by these present.

SIGNED, Sealed and dated this _____ day of _____, 2018.

WHEREAS, the said Principal is herewith submitting a Proposal for

Tubular Steel Structures

and the Principal desires to file this Bid Bond in lieu of making the cash deposit as required by the bidding documents contained herein;

NOW, THEREFORE, THE CONDITION OF THE ABOVE OBLIGATION is such that if the principal shall be awarded the Purchase Order for which the bid is submitted and shall accept the Purchase Order within ten (10) days after the award of same to the principal, then this obligation shall be null and void; but if the principal fails to so accept such Purchase Order as required by the bidding documents contained herein, the Surety shall, upon demand, forthwith pay to the Obligee the amount set forth in the first paragraph hereof, and upon failure to forthwith make such payment, the Surety shall pay the Obligee an amount equal to double the amount of this Bid Bond as set forth in the first paragraph hereof. Power of Attorney from the Surety to its Attorney-in-Fact is attached hereto.

Principal

By _____ (SEAL)

Corporate Surety

By _____ (SEAL)

Three (3) hard copies and One (1) Electronic copy of your proposal should be received

No later than January 27, 2022 at 3:00 pm (EDST).

NO BIDS CONSIDERED UNLESS SUBMITTED ON THIS FORM(S)

RETURN ONLY BID SECURITY, THIS FORM, COST FORM, EXCEPTION FORM,

E-VERIFY FORM(S)

[Balance of page left blank intentionally]

GREENVILLE UTILITIES COMMISSION

EXCEPTION/VARIATION FORM

FOR TUBULAR STEEL STRUCTURES

Provider's Certification: This is to certify that it is our intent to furnish equipment, material, services, etc. in absolute compliance with the bid specification except where expressly noted below.

Instructions: List all exceptions or variations to these bid specifications. Providers shall identify each exception or variation by specification page. The omission of exception or variation information shall be deemed by the Commission as the Provider's intent to absolutely comply with the bid specification. If additional space is required, Provider may reproduce this form as necessary.

<u>Page #</u>	<u>Exception/Variation</u>
_____	_____
_____	_____
_____	_____
_____	_____
_____	_____
_____	_____
_____	_____
_____	_____
_____	_____
_____	_____

Authorized Signature of Certification: _____

Print Name: _____

Firm Represented: _____

Address: _____

Letter of Compliance to E-Verify for Greenville Utilities Commission

1. I have submitted a bid for contract or desire to enter into a contract with the Greenville Utilities Commission;
2. As part of my duties and responsibilities pursuant to said bid and/or contract, I affirm that I am aware of and in compliance with the requirements of E-Verify, Article 2 of Chapter 64 of the North Carolina General Statutes, to include (mark which applies):
3. ____ After hiring an employee to work in the United States I verify the work authorization of said employee through E-Verify and retain the record of the verification of work authorization while the employee is employed and for one year thereafter; or
4. ____ I employ less than fifteen (15) employees in the State of North Carolina.
5. As part of my duties and responsibilities pursuant to said bid and/or contract, I affirm that to the best of my knowledge and subcontractors employed as a part of this bid and/or contract, are in compliance with the requirements of E-Verify, Article 2 of Chapter 64 of the North Carolina General Statutes, to include (mark which applies):
6. ____ After hiring an employee to work in the United States the subcontractor verifies the work authorization of said employee through E-Verify and retains the record of the verification of work authorization while the employee is employed and for one year thereafter; or
7. ____ Employ less than fifteen (15) employees in the State of North Carolina.

Specify subcontractor: _____

_____ (Company Name)

By: _____ (Typed Name)

_____ (Authorized Signatory)

_____ (Title)

_____ (Date)

SECTION III

TERMS AND CONDITIONS FOR THE PURCHASE OF APPARATUS, SUPPLIES, MATERIALS, AND EQUIPMENT

These Terms and Conditions, made and entered into on this the ____ day of _____, by and between GREENVILLE UTILITIES COMMISSION OF THE CITY OF GREENVILLE, PITT COUNTY, NORTH CAROLINA, with one of its principal offices and places of business at 401 S. Greene Street, Post Office Box 1847, Greenville, Pitt County, North Carolina 27835-1847, hereinafter referred to as “GUC” and _____, a _____ organized and existing under and by virtue of the laws of the State of _____, with one of its principal offices and places of business at _____, hereinafter referred to as “PROVIDER”;

1.0 TAXES

No taxes shall be included in any bid prices. GUC is exempt from Federal Excise Tax. GUC is not exempt from North Carolina state sales and use tax or, if applicable, Pitt County sales and use tax. Such taxes shall be shown as a separate item on the invoice.

2.0 INVOICES

It is understood and agreed that orders will be shipped at the established contract prices and quantities in effect on dates orders are placed. Invoicing at variance with this provision may subject the contract to cancellation. Applicable North Carolina sales tax shall be invoiced as a separate line item. All invoices must bear the GUC purchase order number. Mail all invoices to Greenville Utilities Commission, Finance Department, P.O. Box 1847, Greenville, NC 27835-1847.

3.0 PAYMENT TERMS

Payments for equipment, materials, or supplies will be made after the receipt and acceptance of the equipment, materials, supplies or services and after submission of a proper invoice. GUC’s normal payment policy is thirty (30) days. GUC will not be responsible for any goods delivered without a purchase order having been issued. Payment will be made in U.S. currency only.

4.0 QUANTITIES

Quantities specified are only estimates of GUC’s requirements. GUC reserves the right to purchase more or less than the stated quantities at prices indicated in the submitted Proposal Form based on our actual needs.

5.0 AFFIRMATIVE ACTION

The Provider will take affirmative action in complying with all Federal and State requirements concerning fair employment and employment of the handicapped, and concerning the treatment of all employees, without discrimination by reason of race, color, religion, sex, national origin, or physical handicap.

6.0 CONDITION AND PACKAGING

Unless otherwise indicated in the bid, it is understood and agreed that any item offered or shipped shall be new and in first class condition, that all containers shall be new and suitable for storage or shipment, and that prices include standard commercial packaging.

7.0 SAMPLES

Samples of items, if required, must be furnished free of expense to GUC, and if not destroyed, will, upon request, be returned at the Provider's expense. Request for the return of samples must be made at the bid opening; otherwise, the samples will become GUC's property. Each individual sample must be labeled with Provider's name.

8.0 SPECIFICATIONS

Any deviation from specifications must be clearly pointed out, otherwise, it will be considered that items offered are in strict compliance with specifications, and the Provider will be held responsible. Deviations must be explained in detail. **The Provider shall not construe this paragraph as inviting deviation or implying that any deviation will be acceptable.**

9.0 INFORMATION AND DESCRIPTIVE LITERATURE

Providers are to furnish all information requested. Further, as may be specified elsewhere, each Provider must submit with its proposal: cuts, sketches, descriptive literature, and/or complete specifications covering the products offered. Reference to literature submitted with a previous bid does not satisfy this provision. Bids which do not comply with these requirements will be subject to rejection.

10.0 AWARD OF CONTRACT

As directed by statute, qualified bids will be evaluated and acceptance made of the lowest responsible, responsive bid most advantageous to GUC as determined upon consideration of such factors as prices offered, the quality of the article(s) offered, the general reputation and performance capabilities of the Provider, substantial conformity with the specifications and other conditions set forth in the bid, the suitability of the article(s) for the intended use, the related services needed, the date(s) of delivery and performance, and such other factors deemed by GUC to be pertinent or peculiar to the purchase in question.

Acceptance of the order includes acceptance of all terms, conditions, prices, delivery instructions, and specifications as shown on this set of Terms and Conditions and in this order or attached to and made a part of this order.

The conditions of this order cannot be modified except by written amendment in the form of "Amended Purchase Order," which has been approved by GUC's Procurement Manager.

In the event of a Provider's failure to deliver or perform as specified, GUC reserves the right to cancel the order or any part thereof, without prejudice to GUC's other rights. The Provider agrees that GUC may return part of or all of any shipment at Provider's expense. GUC may charge the Provider with all reasonable expenses resulting from such failure to deliver or perform.

11.0 MEDIATION/BINDING ARBITRATION

In the event of any dispute between the Parties, the Parties agree to submit any dispute to non-binding mediation before a mutually agreeable Mediator prior to initiating litigation. If the Parties are unable to agree upon a Mediator within thirty (30) days after demand therefore, either Party may petition a Court of competent jurisdiction for the designation of a qualified Mediator for these purposes. Each Party shall bear its own costs and expenses of participating in the mediation (including, without limitation, reasonable attorneys' fees), and each Party shall bear one-half (1/2) of the costs and expenses of the Mediator. Unless otherwise agreed, the Parties will hold the mediation in Greenville, North Carolina. The matters discussed or revealed in the mediation session shall not be disclosed in any subsequent litigation.

In the event the matter is not resolved in mediation, either Party may request arbitration. The parties shall jointly select an Arbitrator, and shall be bound by the decision of the Arbitrator with respect to any dispute between the parties with respect to this Agreement. If the parties are unable to mutually agree upon an Arbitrator, the Parties shall each select an Arbitrator, and the two Arbitrators so selected shall select a third Arbitrator, and the decision of the majority of the Arbitrators shall be conclusive and binding upon the Parties. The Parties at all times agree to equally split the costs of any Arbitrator(s) selected in an effort to resolve the dispute between the Parties. Any party desiring to resolve a dispute under the terms of this Agreement shall notify the other Party in writing, and the Parties shall seek to agree upon a mutually agreed-upon Arbitrator within a period of ten (10) days from the date of such written demand. If the Parties are unable to agree within such ten (10) day period, the Parties shall each select an Arbitrator, and the two (2) Arbitrators so selected shall select a third Arbitrator within fifteen (15) days from the date of the written demand for arbitration, and a decision shall be rendered by the Arbitrator(s) so selected within five (5) days after such Arbitrator(s) is selected.

12.0 GOVERNMENT RESTRICTIONS

In the event any Governmental restrictions may be imposed which would necessitate alteration of the material, quality, workmanship, or performance of the items offered on this bid prior to their delivery, it shall be the responsibility of the successful Provider to notify the GUC Procurement Manager, at once, indicating in its letter the specific regulation which required such alterations. GUC reserves the right to accept any such alterations, including any price adjustments occasioned thereby, or, in the sole discretion of GUC, to cancel the contract.

13.0 INSURANCE

13.1 Coverage – During the term of the contract, the Provider at its sole cost and expense shall provide commercial insurance of such type and with the following coverage and limits:

13.1.1 Workers' Compensation – The Provider shall provide and maintain Workers' Compensation Insurance, as required by the laws of North Carolina, as well as employer's liability coverage with minimum limits of \$1,000,000 each accident, covering all Providers' employees who are engaged in any work under the contract. If any work is sublet, the Provider shall require the subcontractor to provide the same coverage for any of its employees engaged in any work under the contract.

13.1.2 General Liability – Commercial Liability Coverage written on an “occurrence” basis in the minimum amount of \$1,000,000 per occurrence.

13.1.3 Automobile – Automobile Liability Insurance, to include coverage for all owned, hired, and non-owned vehicles used in connection with the contract with a minimum combined single limit of \$1,000,000 per accident.

13.2 Requirements - Providing and maintaining adequate insurance coverage is a material obligation of the Provider. All such insurance shall meet all laws of the State of North Carolina. Such insurance coverage shall be obtained from companies that are authorized to provide such coverage and that are authorized to do business in North Carolina by the Commissioner of Insurance. The Provider shall at all times comply with the terms of such insurance policies and all requirements of the insurer under any of such insurance policies, except as they may conflict with existing North Carolina laws or this contract. The limits of coverage under each insurance policy maintained by the Provider shall not be interpreted as limiting the Provider’s liability and obligations under the contract. It is agreed that the coverage as stated shall not be canceled or changed until thirty (30) days after written notice of such termination or alteration has been sent by registered mail to GUC’s Procurement Manager.

14.0 PATENTS AND COPYRIGHTS

The Provider shall hold and save GUC, its officers, agents, and employees, harmless from liability of any kind, including costs and expenses, including reasonable attorney fees, on account of any copyrighted articles or any patented or unpatented invention, device or appliance manufactured or used in the performance of this contract.

15.0 PATENT AND COPYRIGHT INDEMNITY

The Provider will defend or settle, at its own expense, any action brought against GUC to the extent that it is based on a claim that the product(s) provided pursuant to this agreement infringe any U.S. copyright or patent; and will pay those costs, damages, and attorney fees finally awarded against GUC in any such action attributable to any such claim, but such defense, settlements, and payments are conditioned on the following: (1) that Provider shall be notified promptly in writing by GUC of any such claim; (2) that Provider shall have sole control of the defense of any action on such claim and of all negotiations for its settlement or compromise; (3) that GUC shall cooperate with Provider in a reasonable way to facilitate the settlement of defense of such claim; (4) that such claim does not arise from GUC modifications not authorized by the Provider or from the use of combination of products provided by the Provider with products provided by GUC or by others; and (5) should such product(s) become, or in the Provider’s opinion likely to become, the subject of such claim of infringement, then GUC shall permit Provider, at Provider’s option and expense, either to procure for GUC the right to continue using the product(s), or replace or modify the same so that it becomes non-infringing and performs in a substantially similar manner to the original product.

16.0 EXCEPTIONS

All proposals are subject to the terms and conditions outlined herein. All responses will be controlled by such terms and conditions and the submission of other terms and conditions, price catalogs, and other documents as part of a Provider's response will be waived and have no effect on this Request for Proposal or any other contract that may be awarded resulting from this solicitation. The submission of any other terms and conditions by a Provider may be grounds for rejection of the Provider's proposal. The Provider specifically agrees to the terms and conditions set forth in this set of Terms and Conditions by affixing its name on the signatory page contained herein.

17.0 CONFIDENTIAL INFORMATION

Except as provided by statute and rule of law, GUC will keep trade secrets in which the Provider does not wish disclosed confidential. Each page shall be identified in boldface at the top and bottom as "CONFIDENTIAL" by the Provider. Cost information shall not be deemed confidential. The determination of whether a matter is confidential will be determined by North Carolina law.

18.0 ASSIGNMENT

No assignment of the Provider's obligations or the Provider's right to receive payment hereunder shall be permitted without the express written consent of GUC, provided however, upon written request approved by the GUC Procurement Manager, solely as a convenience to the Provider, GUC may:

- Forward the Provider's payment check directly to any person or entity designated by the Provider, and
- Include any person or entity designated by Provider as a joint payee on the Provider's payment check.
- In no event shall such approval and action obligate GUC to anyone other than the Provider, and the Provider shall remain responsible for fulfillment of all contract obligations.

19.0 ACCESS TO PERSON AND RECORDS

GUC shall have reasonable access to persons and records of Provider as a result of all contracts entered into by GUC.

20.0 INSPECTION AT BIDDER'S SITE

GUC reserves the right to inspect, at a reasonable time, the item, plant, or other facilities of a prospective Provider prior to contract award and during the contract term as necessary for GUC's determination that such item, plant, or other facilities conform to the specifications/requirements and are adequate and suitable for the proper and effective performance of the contract. Provider may limit GUC's access to restricted areas.

21.0 AVAILABILITY OF FUNDS

Any and all payments of compensation of this specific transaction and any continuation or any

renewal or extension are dependent upon and subject to the allocation of GUC funds for the purpose set forth in this Agreement.

22.0 GOVERNING LAWS

All contracts, transactions, agreements, etc., are made under and shall be governed by and construed in accordance with the laws of the State of North Carolina.

23.0 ADMINISTRATIVE CODE

Bids, proposals, and awards are subject to applicable provisions of the North Carolina Administrative Code and General Statutes and Laws of the State of North Carolina.

24.0 EXECUTION

In the discretion of GUC, failure of a duly authorized official of Provider to sign the Signatory Page may render the bid invalid.

25.0 CLARIFICATIONS/INTERPRETATIONS

Any and all questions regarding these Terms and Conditions must be addressed to the GUC Procurement Manager. Do not contact the user directly. **These Terms and Conditions are a complete statement of the parties' agreement and may only be modified in writing signed by Provider and the GUC Procurement Manager.**

26.0 SITUS

The place of all contracts, transactions, agreements, their situs and forum, shall be North Carolina, where all matters, whether in contract or tort, relating to the validity, construction, interpretation, and enforcement shall be determined.

27.0 TERMINATION OF AGREEMENT

GUC or Provider may terminate this Agreement for just cause at any time. Provider will be paid for all time and expenses incurred as of the termination date. Termination for just cause by either party shall be by certified letter and shall be effective thirty (30) days after signed and acknowledged receipt of said letter. Just cause shall be based on reasonable grounds, and there must be a fair and honest cause or reason for such action. The causes for termination, include, but are not limited to: (1) Provider's persistent failure to perform in accordance with the Terms and Conditions, (2) Provider's disregard of laws and regulations related to this transaction, and/or (3) Provider's substantial violation of the provisions of the Terms and Conditions.

28.0 DELIVERY

Shipments will be made only upon releases from a purchase order issued by GUC in accordance with GUC's current needs.

Time is of the essence with respect to all deliveries under this Agreement. Delivery of all equipment, materials, or supplies shall be made Free on Board (FOB) GUC Warehouse, 701 Utility Way, Greenville, North Carolina 27834, unless otherwise specified. The agreed price for such equipment, materials, or supplies shall include all costs of delivery and ownership, and risks of loss shall not be transferred from Provider to GUC until express written acceptance of

delivery and inspection by GUC. Delivery hours are between 8:00 AM and 4:30 PM Tuesday-Thursday only. **GUC's purchase order number is to be shown on the packing slip or any related documents.** GUC reserves the right to refuse or return any delivery with no purchase order number or which is damaged. GUC will not be charged a restocking fee for any delivery which is refused or returned.

29.0 INDEMNITY PROVISION

Provider agrees to indemnify and save GREENVILLE UTILITIES COMMISSION of the City of Greenville, Pitt County, North Carolina, and the City of Greenville, North Carolina, its co-owners, joint venturers, agents, employees, and insurance carriers harmless from any and all losses, claims, actions, costs, expenses including reasonable attorney fees, judgments, subrogations, or other damages resulting from injury to any person (including injury resulting in death), or damage (including loss or destruction) to property of whatsoever nature of any person arising out of or incident to the performance of the terms of this Contract by Provider, including, but not limited to, Provider's employees, agents, subcontractors, and others designated by Provider to perform work or services in, about, or attendant to, the work and services under the terms of this Contract. Provider shall not be held responsible for any losses, expenses, claims, subrogations, actions, costs, judgments, or other damages, directly, solely, and proximately caused by the negligence of Greenville Utilities Commission of the City of Greenville, Pitt County, North Carolina. Insurance covering this indemnity agreement by the Provider in favor of Greenville Utilities Commission of the City of Greenville, Pitt County, North Carolina, and the City of Greenville, North Carolina, shall be provided by Provider.

30.0 FORCE MAJEURE

Neither party shall be considered in default in the performance of its obligations hereunder to the extent that the performance of any such obligation is prevented or delayed by any cause, existing or future, which is beyond the reasonable control of such party. In any such event of force majeure, the parties shall advise each other of such event, and the parties shall negotiate an equitable adjustment to their respective obligations under this Agreement.

31.0 WARRANTY(IES)

The Provider hereby includes all warranties, whether expressed or implied, including, but not limited to, the Implied Warranty of Merchantability and the Implied Warranty of Fitness for a Particular Purpose.

32.0 INTEGRATED CONTRACT

These Terms and Conditions, Instructions to Bidders, Specifications, and the selected Provider's bid represents the entire contract between the Parties. No verbal or other written agreement(s) shall be held to vary the provisions of this Agreement.

33.0 CONTRACT PROVISIONS

Each of the provisions of these Terms and Conditions shall apply to the full extent permitted by law, and the invalidity in whole or in part of any provision shall not affect the remainder of such provision or any other provisions.

34.0 E-VERIFY

E-Verify - I understand that E-Verify is the federal E-Verify program operated by the United States Department of Homeland Security and other federal agencies, or any successor or equivalent program used to verify the work authorization of newly hired employees pursuant to federal law in accordance with NCGS §64-25 et seq. I am aware of and in compliance with the requirements of E-Verify and Article 2 of Chapter 64 of the North Carolina General Statutes. To the best of my knowledge, any subcontractors employed by me as a part of this contract are in compliance with the requirements of E-Verify and Article 2 of Chapter 64 of the North Carolina General Statutes.

35.0 IRAN DIVESTMENT ACT CERTIFICATION

By acceptance of this purchase order, Vendor/Contractor certifies that, as of the date of the purchase order or contract, it is not on the Final Divestment List as created by the State Treasurer pursuant to N.C.G.S. § 143-6A-4. In compliance with the requirements of the Iran Divestment Act and N.C.G.S. § 143C-6A-5(b), Vendor/Contractor shall not utilize in the performance of the contract any subcontractor that is identified on the Final Divestment List.

36.0 UNIFORM GUIDANCE

Contracts funded with federal grant or loan funds must be procured in a manner that conforms with all applicable federal laws, policies, and standards, including those under the Uniform Guidance (2 C.F.R. Part 200).

37.0 NOTICES

Notices to the Parties should be sent to the names and addresses specified below:

Cleve Haddock, CLGPO
Procurement Manager
Greenville Utilities Commission
P.O. Box 1847
Greenville, NC 27835-1847

Vendor Specified on Page 1 of Section III when awarded.

GREENVILLE UTILITIES COMMISSION

COMPANY NAME:

By: _____
Anthony C. Cannon

By: _____

Title: General Manager/CEO
(Authorized Signatory)

Name (Print): _____

Title: _____
(Authorized Signatory)

Date: _____

Date: _____

Attest: _____

Attest: _____

Name (Print): Amy Wade

Name (Print): _____

Title: Executive Secretary

Title: Corporate Secretary

Date: _____

Date: _____

(OFFICIAL SEAL)

(CORP. SEAL)

This instrument has been pre-audited in the manner required by the Local Government Budget and Fiscal Control Act.

By: _____
Jeff W. McCauley

Title: Chief Financial Officer

Date: _____

APPROVED AS TO FORM AND LEGAL CONTENT:

By: _____
Phillip R. Dixon

Title: General Counsel

Date: _____