

ADVERTISEMENT FOR BIDS

Sealed proposals will be received in the Office of the Procurement Manager, Greenville Utilities Commission, 401 S. Greene Street, Greenville, North Carolina 27834 until 2:00 PM (EST) on **January 12, 2023** and immediately thereafter publicly opened and read for the furnishing of **Wood Distribution Poles**.

Instructions for submitting bids and complete specifications will be available in the Office of the Procurement Manager, Greenville Utilities Commission, 401 S. Greene Street, Greenville, North Carolina during regular office hours, which are 8:30AM – 5:00PM Monday through Friday.

Greenville Utilities Commission reserves the right to reject any or all bids. **Late bids will not be considered.**

Notice to Bidders:

Greenville Utilities Commission is committed to the health and safety of our customers and employees. We are taking the spread of COVID-19 very seriously and continue to monitor the latest Local, State, and Federal guidance.

SECTION I

GENERAL INSTRUCTIONS FOR FORMAL BIDS

RELATED TO THE PURCHASE OF APPARATUS, SUPPLIES,

MATERIALS, AND EQUIPMENT

1.0 NOTICE TO BIDDERS

Sealed bids, subject to the conditions made a part hereof, will be received in the Office of the Procurement Manager, Greenville Utilities Commission, 401 S. Greene Street, Greenville, North Carolina 27834 until 2:00 PM (EST) on the day of opening. **Bids submitted in a fax or e-mail in response to this Invitation for Bids will not be acceptable. Late Bids will not be considered.**

2.0 STANDARD FORMS REQUIRED

Each bidder must submit a proposal on the enclosed bid forms. **The bid must be signed by an authorized official of the firm. Return only the attached Proposal Form. Do not return the Advertisement for Bids, Instructions to Bidders or Specifications.**

3.0 PREPARATION OF BID

Bids must be in sealed envelopes clearly marked on the outside with the name of the bid and the bid opening date and time. Bid shall be addressed to PROCUREMENT MANAGER, GREENVILLE UTILITIES COMMISSION, 401 S. GREENE STREET, GREENVILLE, NORTH CAROLINA, 27834.

4.0 TIME FOR OPENING BIDS

Bids will be opened promptly and read at the hour and on the date set forth in the advertisement in the Office of the Procurement Manager, Greenville Utilities Main Office, 401 S. Greene Street, Greenville, North Carolina. Bidders or their authorized agents are invited to be present.

5.0 DEPOSIT

A deposit is NOT required for this bid.

6.0 NC SALES TAX

Do **not** include NC sales taxes in bid figure; however, Greenville Utilities Commission (GUC) does pay sales tax. Sales tax should be added to the invoice as a separate item.

7.0 FEDERAL EXCISE TAX

GUC is exempt from Federal Excise Tax and will issue a Federal Exemption Certificate upon request to the successful bidder.

8.0 EXCEPTIONS TO BE CLEARLY STATED

If bid is not in strict accordance with Section II, "Specifications," bidder must list or note all exceptions **on the Request for Proposal Form**, otherwise, it is fully understood that the successful bidder will furnish equipment and/or materials exactly as specified. GUC reserves the right to accept or reject bids with noted minor deviations from specifications and to determine the lowest responsible, responsive bid from the standpoint of quality, performance, delivery, and price.

9.0 EVALUATION AND AWARD OF BIDS

GUC reserves the right to reject any and all bids, to waive any and all informalities, and to disregard all nonconforming or conditional bids or counter proposals. In evaluating bids, GUC shall consider whether the bids comply with the prescribed requirements, plus all alternates or options requested. GUC reserves the right to include or exclude any option or alternative in GUC's opinion is in GUC's best interests. If a bid is to be awarded, it will be awarded to the lowest responsible, responsive bidder whose evaluation by GUC indicates that the award will be in GUC's best interests.

10.0 PROMPT PAYMENT DISCOUNTS

Bidders are urged to compute all discounts into the price offered. If a prompt payment discount is offered, it may be considered in the award of the contract.

11.0 NUMERICAL ERRORS

In the case of a discrepancy between a unit price and the extension (the unit price multiplied by the number of units), the unit price governs. In the case where numerical bids are stated both in numbers and in words, the words govern.

12.0 BID WITHDRAWAL

A bidder must notify GUC in writing of its request to withdraw a bid within seventy-two (72) hours after the bid opening, not including Saturdays, Sundays, or holidays. In order to justify withdrawal, the bidder must demonstrate that a substantial error exists and that the bid was submitted in good faith.

13.0 MINORITY BUSINESS PARTICIPATION PROGRAM

GUC has adopted an Affirmative Action and Minority and Women Business Enterprise Plan (M/WBE) Program. Firms submitting a proposal are attesting that they also have taken affirmative action to ensure equality of opportunity in all aspects of employment, and to utilize M/WBE suppliers of materials and/or labor.

14.0 QUANTITIES

Quantities specified are only estimates of GUC's requirements. GUC reserves the right to purchase more or less than the stated quantities at prices indicated in the submitted Proposal Form based on our actual needs.

15.0 DELIVERY

Shipments will be made only upon releases from a purchase order issued by GUC in accordance with GUC's current needs.

Time is of the essence with respect to all deliveries under this Agreement.

Delivery of all equipment, materials, or supplies shall be made Free on Board (FOB) GUC Warehouse, 701 Utility Way, Greenville, North Carolina 27834, unless otherwise specified. The agreed price for such equipment, materials, or supplies shall include all costs of delivery and ownership, and risks of loss shall not be transferred from Provider to GUC until express written acceptance of delivery and inspection by GUC. Delivery hours are between 8:00 AM and 4:30 PM Monday-Friday only. **GUC's purchase order number is to be shown on the packing slip or any related documents.** GUC reserves the right to refuse or return any delivery with no purchase order number or which is damaged. GUC will not be charged a restocking fee for any delivery which is refused or returned.

16.0 CONTACT INFORMATION

Questions regarding this bid request should be directed to Cleve Haddock, CLGPO, Procurement Manager at (252) 551-1533, haddocgc@guc.com

17.0 CONTRACT PERIOD

It is the intent of Greenville Utilities Commission (GUC) to enter into a multi-year contract at the time the contract is awarded by GUC to the successful bidder for a total contract period not to exceed three (3) years. Option for annual extensions at the same or negotiated unit prices for up to two (2) additional years if market and service conditions so warrant and prove to be in the best interest of GUC.

18.0 TERMS AND CONDITIONS

The attached Terms and Conditions must be considered by all vendors as part of the bid proposal.

SECTION II

GREENVILLE UTILITIES COMMISSION

WOOD DISTRIBUTION POLE SPECIFICATIONS

CCA-TREATED SOUTHERN PINE DIST POLES

1.0 MATERIAL

Specifications for southern yellow pine poles. All lengths and classes shall meet the requirements set forth in ANSI specifications and dimensions for wood poles 05.1, latest version except as amended by the following:

1.1 Paragraph 4.4.9

- 1.1.1 (a) The maximum sweep in one plane and one direction in any pole equal to or less than 70' shall not exceed 1 inch in 10 feet in length as measured by a straight line from the tip to the pole butt.
- 1.1.1 (b) The maximum sweep in one plane and one direction for poles greater than 70' shall not exceed 1 inch in 20 feet as measured by a straight line from the tip to the pole butt.
- 1.1.2 Sweep in two directions in the same plane (reverse sweep) shall be measured by a straight line connection the midpoint at the top and the midpoint at the ground line. The line shall lie entirely within the body of the pole and shall not at any intermediate point pass closer than 1 inch to its surface.
- 1.1.3 Sweep in two planes (double sweep) is prohibited.

1.2 All poles shall be free of short crooks.

1.3 The bottom of the brand shall be located on the face of the pole at a point 10 feet, plus or minus 1 inch, from the butt on all poles 50 feet and shorter, and 14 feet, plus or minus 1 inch, from the butt on all poles 55 feet and longer.

1.4 The supplier's code or trademark, year of manufacture, length and class of each pole shall be branded or hammer stamped in the butt. At the option of the supplier, and at no additional cost to the purchaser, a non-ferrous material tag embossed with the length and class may be affixed to the butt of each pole in addition to the information to be branded, labeled or hammer stamped.

2.0 PRESERVATIVE

2.1 All poles shall be treated with CCA-C oxide preservative.

2.2 CCA-Type C waterborne preservative used in the treatment of utility poles shall be of the oxide form as specified in AWPA Standard P5-11 and T1-11 Section D or latest revision. Unacceptable constituents are copper sulfate, sodium arsenate, or pyroarsenate, potassium or sodium dichromate, or other constituents that will form water soluble electrolytes in utility poles.

3.0 TREATMENT

3.1 Poles will be treated in accordance with the requirements of the American Wood Protection Association standard C1, "All Timber Products-Preservative Treatment by Pressure Process, and T1-11 Section D, Preservative Treatment with Waterborne Preservatives", except as noted in the specification.

3.2 CONDITIONING

3.2.1 Poles should have a moisture content of 35% or less in the third inch from the surface of the pole.

3.2.2 Only kiln-drying are permitted.

3.2.3 Poles must be cool prior to treatment.

3.3 TREATMENT

3.3.1 A maximum pressure of 200 psi for unlimited duration is permitted.

3.3.2 A maximum fixation period of six hours by heating in steam or hot water at 220 degree F is permitted in southern pine poles only.

3.4 RESULTS OF TREATMENT

3.4.1 Retention- poles to be treated to a minimum retention level of 0.60 pcf as determined by an assay of the 0.50" to 2.0" zone of wood from the poles surface.

3.4.2 Penetration-Poles shall be penetrated in accordance with A.W.P.A. Standard T1-11 Section D7A, 3.5" or 90%, whichever is less.

3.5 RETREATMENT

Poles may be retreated providing none of the limitations specified in A.W.P.A. Standard M1-11, section 6, paragraph 6-retreatment are exceeded.

4.0 FRAMING

All poles shall be shall be properly gaged and framed with a high pitch, single slope roof in accordance with Drawing DGEC. The single gain will be 4" wide and extend 21" down from the pole top. The through bolt holes will be 11/16" in diameter and located at 4", 9", 12" and 18" from the pole top all in the same plane with an additional side hole at 42" from the pole top in a plane 90 degrees from the gain .

5.0 INSPECTION

All poles shall be inspected at the pole treating plant before and after preservative treatment by a qualified representative of an independent and accredited inspection firm which maintains an accredited analytical laboratory and field staff meeting the criteria in RUS for wood pole inspectors as approved by The Electricities Operations Standards Team.

- 5.1 Each charge of poles shall have 100% of poles tested for penetration. Each accepted pole must bear in the top the independent inspection firm's hammer mark and inspector number indicating acceptance before it is placed in the cylinder for treatment. After the charge of poles has been tested for penetration and retention the inspection firm shall hammer the butt end of each pole indicating conformance to this specification.
- 5.2 The purchaser shall reserve the right to make final inspection before acceptance at destination.
- 5.3 The waiving of inspections shall not relieve the supplier of their responsibility to furnish material in accordance with this specification.

6.0 SHIPMENT

No pole shall be loaded by the supplier for shipment unless it bears imprint of the two marks indicating acceptance by the inspector before and after treatment.

7.0 SHIP BY TRUCK

Truck to be equipped with boom and poles unloaded at the Purchasers pole yard by the supplier. An exception may be made for poles 65 feet and longer. Cost to be included in bid. Deliveries will be accepted Monday through Friday as stated on purchase order. No deliveries will be accepted on holidays or weekends unless requested by purchaser.

Vendor Name: _____

GREENVILLE UTILITIES COMMISSION

PROPOSAL FORM

JANUARY 12, 2023

The undersigned bidder hereby declares that it has carefully examined the enclosed detailed specifications for furnishing GUC with the below listed items. The undersigned bidder further agrees, if this proposal is accepted within sixty (60) days from the date of the opening, to furnish any or all of the items upon the quoted price.

Stock #	Size	Class	Estimated Annual Usage	Unit Price	Subtotal	Freight per pole	F.O.B per pole	Total
203870	35	5	450	\$	\$	\$	\$	\$
203880	40	4	215	\$	\$	\$	\$	\$
203890	45	4	250	\$	\$	\$	\$	\$
206420	50	3	90	\$	\$	\$	\$	\$
203940	55	3	30	\$	\$	\$	\$	\$
206030	60	2	15	\$	\$	\$	\$	\$
206330	65	2	10	\$	\$	\$	\$	\$
							Total	\$

Method of Award: Items above will be awarded as a total bid.

Complete and Check All Math: It is the responsibility of the Bidder to extend bid prices and supply a total for all items. It is certified that this proposal is made in good faith and without collusion or connection with any other person bidding on the same above listed items. It is also certified that this proposal is made in good faith and without collusion or connection with any GUC employee(s).

The Undersigned Bidder: hereby declares that it has carefully examined the enclosed detailed specifications for furnishing GUC with the below listed items. The undersigned bidder further agrees, if this proposal is accepted within thirty (30) days from the date of the opening, to furnish any or all of the items upon the quoted price.

[Balance of page left blank intentionally]

Letter of Compliance to E-Verify for Greenville Utilities Commission

1. I have submitted a bid for contract or desire to enter into a contract with the Greenville Utilities Commission;
2. As part of my duties and responsibilities pursuant to said bid and/or contract, I affirm that I am aware of and in compliance with the requirements of E-Verify, Article 2 of Chapter 64 of the North Carolina General Statutes, to include (mark which applies):

3. ____ After hiring an employee to work in the United States I verify the work authorization of said employee through E-Verify and retain the record of the verification of work authorization while the employee is employed and for one year thereafter; or
4. ____ I employ less than twenty-five (25) employees in the State of North Carolina.

5. As part of my duties and responsibilities pursuant to said bid and/or contract, I affirm that to the best of my knowledge and subcontractors employed as a part of this bid and/or contract, are in compliance with the requirements of E-Verify, Article 2 of Chapter 64 of the North Carolina General Statutes, to include (mark which applies):

6. ____ After hiring an employee to work in the United States the subcontractor verifies the work authorization of said employee through E-Verify and retains the record of the verification of work authorization while the employee is employed and for one year thereafter; or

7. ____ Employ less than twenty-five (25) employees in the State of North Carolina.

Specify subcontractor: _____

_____ (Company Name)

By: _____ (Typed Name)

_____ (Authorized Signatory)

_____ (Title)

_____ (Date)

It is certified that this proposal is made in good faith and without collusion or connection with any other person bidding on the same above listed items. It is also certified that this proposal is made in good faith and without collusion or connection with any GUC employee(s).

Certified check or cash for \$ n/a or bid bond for \$ n/a attached.

Firm Name _____

Phone (_____) _____

Address _____

City _____ State _____ Zip Code _____

Fax (_____) _____ E-Mail _____

Authorized Official _____ Title _____

Typed Name

_____ Date

_____ Signature

Three (3) copies of your proposal should be received no

later than

January 12, 2023 at 2:00 PM (EST).

NO BIDS CONSIDERED UNLESS SUBMITTED ON THIS FORM(S)

(RETURN ONLY THIS FORM, COST FORM, EXCEPTION FORM, E-VERIFY FORM)

SECTION III

TERMS AND CONDITIONS FOR THE PURCHASE OF

APPARATUS, SUPPLIES, MATERIALS, LABOR AND EQUIPMENT

These Terms and Conditions, made and entered into on this the ___ day of _____, by and between GREENVILLE UTILITIES COMMISSION OF THE CITY OF GREENVILLE, PITT COUNTY, NORTH CAROLINA, with one of its principal offices and places of business at 401 S. Greene Street, Post Office Box 1847, Greenville, Pitt County, North Carolina 27835-1847, hereinafter referred to as "GUC" and _____, a _____ organized and existing under and by virtue of the laws of the State of _____, with one of its principal offices and places of business at _____, hereinafter referred to as "PROVIDER";

1.0 TAXES

No taxes shall be included in any bid prices. GUC is exempt from Federal Excise Tax. GUC is not exempt from North Carolina state sales and use tax or, if applicable, Pitt County sales and use tax. Such taxes shall be shown as a separate item on the invoice.

2.0 INVOICES

It is understood and agreed that orders will be shipped at the established contract prices and quantities in effect on dates orders are placed. Invoicing at variance with this provision may subject the contract to cancellation. Applicable North Carolina sales tax shall be invoiced as a separate line item. All invoices must bear the GUC purchase order number. Mail all invoices to Greenville Utilities Commission, Finance Department, P. O. Box 1847, Greenville, NC 27835-1847.

3.0 PAYMENT TERMS

Payments for equipment, materials, or supplies will be made after the receipt and acceptance of the equipment, materials, supplies or services and after submission of a proper invoice. GUC's normal payment policy is thirty (30) days. GUC will not be responsible for any goods delivered without a purchase order having been issued. Payment will be made in U. S. currency only.

4.0 QUANTITIES

Quantities specified are only estimates of GUC's requirements. GUC reserves the right to purchase more or less than the stated quantities at prices indicated in the submitted Proposal Form based on our actual needs.

5.0 AFFIRMATIVE ACTION

The Provider will take affirmative action in complying with all Federal and State requirements concerning fair employment and employment of the handicapped, and concerning the treatment of all employees, without discrimination by reason of race, color, religion, sex, national origin, or physical handicap.

6.0 CONDITION AND PACKAGING

Unless otherwise indicated in the bid, it is understood and agreed that any item offered or shipped shall be new and in first class condition, that all containers shall be new and suitable for storage or shipment, and that prices include standard commercial packaging.

7.0 SAMPLES

Samples of items, if required, must be furnished free of expense to GUC, and if not destroyed, will, upon request, be returned at the Provider's expense. Request for the return of samples must be made at the bid opening, otherwise, the samples will become GUC's property. Each individual sample must be labeled with Provider's name.

8.0 SPECIFICATIONS

Any deviation from specifications must be clearly pointed out, otherwise, it will be considered that items offered are in strict compliance with specifications, and the Provider will be held responsible. Deviations must be explained in detail. **The Provider shall not construe this paragraph as inviting deviation or implying that any deviation will be acceptable.**

9.0 INFORMATION AND DESCRIPTIVE LITERATURE

Providers are to furnish all information requested. Further, as may be specified elsewhere, each Provider must submit with its proposal: cuts, sketches, descriptive literature, and/or complete specifications covering the products offered. Reference to literature submitted with a previous bid does not satisfy this provision. Bids which do not comply with these requirements will be subject to rejection.

10.0 AWARD OF CONTRACT

As directed by statute, qualified bids will be evaluated and acceptance made of the lowest responsible, responsive bid most advantageous to GUC as determined upon consideration of such factors as prices offered, the quality of the article(s) offered, the general reputation and performance capabilities of the Provider, substantial conformity with the specifications and other conditions set forth in the bid, the suitability of the article(s) for the intended use, the related services needed, the date(s) of delivery and performance, and such other factors deemed by GUC to be pertinent or peculiar to the purchase in question.

Acceptance of the order includes acceptance of all terms, conditions, prices, delivery instructions, and specifications as shown on this set of Terms and Conditions and in this order or attached to and made a part of this order.

The conditions of this order cannot be modified except by written amendment in the form of "Amended Purchase Order," which has been approved by GUC's Procurement Manager.

In the event of a Provider's failure to deliver or perform as specified, GUC reserves the right to cancel the order or any part thereof, without prejudice to GUC's other rights. The Provider agrees that GUC may return part of or all of any shipment at Provider's expense. GUC may charge the Provider with all reasonable expenses resulting from such failure to deliver or perform.

11.0 MEDIATION/BINDING ARBITRATION

In the event of any dispute between the Parties, the Parties agree to submit any dispute to non-binding mediation before a mutually agreeable Mediator prior to initiating litigation. If the Parties are unable to agree upon a Mediator within thirty (30) days after demand therefore, either Party may petition a Court of competent jurisdiction for the designation of a qualified Mediator for these purposes. Each Party shall bear its own costs and expenses of participating in the mediation (including, without limitation, reasonable attorneys' fees), and each Party shall bear one-half (1/2) of the costs and expenses of the Mediator. Unless otherwise agreed, the Parties will hold the mediation in Greenville, North Carolina. The matters discussed or revealed in the mediation session shall not be disclosed in any subsequent litigation.

In the event the matter is not resolved in mediation, either Party may request arbitration. The parties shall jointly select an Arbitrator, and shall be bound by the decision of the Arbitrator with respect to any dispute between the parties with respect to this Agreement. If the parties are unable to mutually agree upon an Arbitrator, the Parties shall each select an Arbitrator, and the two Arbitrators so selected shall select a third Arbitrator, and the decision of the majority of the Arbitrators shall be conclusive and binding upon the Parties. The Parties at all times agree to equally split the costs of any Arbitrator(s) selected in an effort to resolve the dispute between the Parties. Any party desiring to resolve a dispute under the terms of this Agreement shall notify the other Party in writing, and the Parties shall seek to agree upon a mutually agreed-upon Arbitrator within a period of ten (10) days from the date of such written demand. If the Parties are unable to agree within such ten (10) day period, the Parties shall each select an Arbitrator, and the two (2) Arbitrators so selected shall select a third Arbitrator within fifteen (15) days from the date of the written demand for arbitration, and a decision shall be rendered by the Arbitrator(s) so selected within five (5) days after such Arbitrator(s) is selected.

12.0 GOVERNMENT RESTRICTIONS

In the event any Governmental restrictions may be imposed which would necessitate alteration of the material, quality, workmanship, or performance of the items offered on this bid prior to their delivery, it shall be the responsibility of the successful Provider to notify the GUC Procurement Manager, at once, indicating in its letter the specific regulation which required such alterations. GUC reserves the right to accept any such alterations, including any price adjustments occasioned thereby, or, in the sole discretion of GUC, to cancel the contract.

13.0 INSURANCE

13.1 Coverage – During the term of the contract, the Provider at its sole cost and expense shall provide commercial insurance of such type and with the following coverage and limits:

13.1.1 Workers' Compensation – The Provider shall provide and maintain Workers' Compensation Insurance, as required by the laws of North Carolina, as well as employer's liability coverage with minimum limits of \$1,000,000 each accident, covering all Provider's employees who are engaged in any work under the contract. If any work is sublet, the Provider shall require the subcontractor to provide the same coverage for any of its employees engaged in any work under the contract.

13.1.2 General Liability – Commercial Liability Coverage written on an “occurrence” basis in the minimum amount of \$1,000,000 per occurrence.

13.1.3 Automobile – Automobile Liability Insurance, to include coverage for all owned, hired, and non-owned vehicles used in connection with the contract with a minimum combined single limit of \$1,000,000 per accident.

13.2 Requirements - Providing and maintaining adequate insurance coverage is a material obligation of the Provider. All such insurance shall meet all laws of the State of North Carolina. Such insurance coverage shall be obtained from companies that are authorized to provide such coverage and that are authorized to do business in North Carolina by the Commissioner of Insurance. The Provider shall at all times comply with the terms of such insurance policies and all requirements of the insurer under any of such insurance policies, except as they may conflict with existing North Carolina laws or this contract. The limits of coverage under each insurance policy maintained by the Provider shall not be interpreted as limiting the Provider’s liability and obligations under the contract. It is agreed that the coverage as stated shall not be canceled or changed until thirty (30) days after written notice of such termination or alteration has been sent by registered mail to GUC’s Procurement Manager.

14.0 PATENTS AND COPYRIGHTS

The Provider shall hold and save GUC, its officers, agents, and employees, harmless from liability of any kind, including costs and expenses, including reasonable attorney fees, on account of any copyrighted articles or any patented or unpatented invention, device or appliance manufactured or used in the performance of this contract.

15.0 PATENT AND COPYRIGHT INDEMNITY

The Provider will defend or settle, at its own expense, any action brought against GUC to the extent that it is based on a claim that the product(s) provided pursuant to this agreement infringe any U.S. copyright or patent; and will pay those costs, damages, and attorney fees finally awarded against GUC in any such action attributable to any such claim, but such defense, settlements, and payments are conditioned on the following: (1) that Provider shall be notified promptly in writing by GUC of any such claim; (2) that Provider shall have sole control of the defense of any action on such claim and of all negotiations for its settlement or compromise; (3) that GUC shall cooperate with Provider in a reasonable way to facilitate the settlement of defense of such claim; (4) that such claim does not arise from GUC modifications not authorized by the Provider or from the use of combination of products provided by the Provider with products provided by GUC or by others; and (5) should such product(s) become, or in the Provider’s opinion likely to become, the subject of such claim of infringement, then GUC shall permit Provider, at Provider’s option and expense, either to procure for GUC the right to continue using the product(s), or replace or modify the same so that it becomes non-infringing and performs in a substantially similar manner to the original product.

16.0 EXCEPTIONS

All proposals are subject to the terms and conditions outlined herein. All responses will be controlled by such terms and conditions and the submission of other terms and conditions, price catalogs, and other documents as part of a Provider's response will be waived and have no effect on this Request for Proposal or any other contract that may be awarded resulting from this solicitation. The submission of any other terms and conditions by a Provider may be grounds for rejection of the Provider's proposal. The Provider specifically agrees to the terms and conditions set forth in this set of Terms and Conditions by affixing its name on the signatory page contained herein.

17.0 CONFIDENTIAL INFORMATION

Except as provided by statute and rule of law, GUC will keep trade secrets which the Provider does not wish disclosed confidential. Each page shall be identified in boldface at the top and bottom as "CONFIDENTIAL" by the Provider. Cost information shall not be deemed confidential. The determination of whether a matter is confidential will be determined by North Carolina law.

18.0 ASSIGNMENT

No assignment of the Provider's obligations or the Provider's right to receive payment hereunder shall be permitted without the express written consent of GUC, provided however, upon written request approved by the GUC Procurement Manager, solely as a convenience to the Provider, GUC may:

- Forward the Provider's payment check directly to any person or entity designated by the Provider, and
- Include any person or entity designated by Provider as a joint payee on the Provider's payment check.
- In no event shall such approval and action obligate GUC to anyone other than the Provider, and the Provider shall remain responsible for fulfillment of all contract obligations.

19.0 ACCESS TO PERSON AND RECORDS

GUC shall have reasonable access to persons and records of Provider as a result of all contracts entered into by GUC.

20.0 INSPECTION AT BIDDER'S SITE

GUC reserves the right to inspect, at a reasonable time, the item, plant, or other facilities of a prospective Provider prior to contract award and during the contract term as necessary for GUC's determination that such item, plant, or other facilities conform with the specifications/requirements and are adequate and suitable for the proper and effective performance of the contract. Provider may limit GUC's access to restricted areas.

21.0 AVAILABILITY OF FUNDS

Any and all payments of compensation of this specific transaction and any continuation or any renewal or extension are dependent upon and subject to the allocation of GUC funds for the purpose set forth in this Agreement.

22.0 GOVERNING LAWS

All contracts, transactions, agreements, etc., are made under and shall be governed by and construed in accordance with the laws of the State of North Carolina.

23.0 ADMINISTRATIVE CODE

Bids, proposals, and awards are subject to applicable provisions of the North Carolina Administrative Code and General Statutes and Laws of the State of North Carolina.

24.0 EXECUTION

In the discretion of GUC, failure of a duly authorized official of Provider to sign the Signatory Page may render the bid invalid.

25.0 CLARIFICATIONS/INTERPRETATIONS

Any and all questions regarding these Terms and Conditions must be addressed to the GUC Procurement Manager. Do not contact the user directly. **These Terms and Conditions are a complete statement of the parties' agreement and may only be modified in writing signed by Provider and the GUC Procurement Manager.**

26.0 SITUS

The place of all contracts, transactions, agreements, their situs and forum, shall be North Carolina, where all matters, whether in contract or tort, relating to the validity, construction, interpretation, and enforcement shall be determined.

27.0 TERMINATION OF AGREEMENT

GUC or Provider may terminate this Agreement for just cause at any time. Provider will be paid for all time and expenses incurred as of the termination date. Termination for just cause by either party shall be by certified letter and shall be effective thirty (30) days after signed and acknowledged receipt of said letter. Just cause shall be based on reasonable grounds, and there must be a fair and honest cause or reason for such action. The causes for termination, include, but are not limited to: (1) Provider's persistent failure to perform in accordance with the Terms and Conditions, (2) Provider's disregard of laws and regulations related to this transaction, and/or (3) Provider's substantial violation of the provisions of the Terms and Conditions.

28.0 DELIVERY

Shipments will be made only upon releases from a purchase order issued by GUC in accordance with GUC's current needs.

Time is of the essence with respect to all deliveries under this Agreement. Delivery of all equipment, materials, or supplies shall be made Free on Board (FOB) GUC Warehouse, 701 Utility Way, Greenville, North Carolina 27834, unless otherwise specified. The agreed price for such equipment, materials, or supplies shall include all costs of delivery and ownership, and risks of loss shall not be transferred from Provider to GUC until express written acceptance of delivery and inspection by GUC. Delivery hours are between 8:00 AM and 4:30 PM Monday-Friday only. **GUC's purchase order number is to be shown on the packing slip or any related documents.** GUC reserves the right to refuse or return any delivery with no purchase order number or which is damaged. GUC will not be charged a restocking fee for any delivery which is refused or returned.

29.0 INDEMNITY PROVISION

Provider agrees to indemnify and save GREENVILLE UTILITIES COMMISSION of the City of Greenville, Pitt County, North Carolina, and the City of Greenville, North Carolina, its co-owners, joint venturers, agents, employees, and insurance carriers harmless from any and all losses, claims, actions, costs, expenses including reasonable attorney fees, judgments, subrogations, or other damages resulting from injury to any person (including injury resulting in death), or damage (including loss or destruction) to property of whatsoever nature of any person arising out of or incident to the performance of the terms of this Contract by Provider, including, but not limited to, Provider's employees, agents, subcontractors, and others designated by Provider to perform work or services in, about, or attendant to, the work and services under the terms of this Contract. Provider shall not be held responsible for any losses, expenses, claims, subrogations, actions, costs, judgments, or other damages, directly, solely, and proximately caused by the negligence of Greenville Utilities Commission of the City of Greenville, Pitt County, North Carolina. Insurance covering this indemnity agreement by the Provider in favor of Greenville Utilities Commission of the City of Greenville, Pitt County, North Carolina, and the City of Greenville, North Carolina, shall be provided by Provider.

30.0 FORCE MAJEURE

Neither party shall be considered in default in the performance of its obligations hereunder to the extent that the performance of any such obligation is prevented or delayed by any cause, existing or future, which is beyond the reasonable control of such party. In any such event of force majeure, the parties shall advise each other of such event, and the parties shall negotiate an equitable adjustment to their respective obligations under this Agreement.

31.0 WARRANTY(IES)

The Provider hereby includes all warranties, whether expressed or implied, including, but not limited to, the Implied Warranty of Merchantability and the Implied Warranty of Fitness for a Particular Purpose.

32.0 INTEGRATED CONTRACT

These Terms and Conditions, Instructions to Bidders, Specifications, and the selected Provider's bid represents the entire contract between the Parties. No verbal or other written agreement(s) shall be held to vary the provisions of this Agreement.

33.0 CONTRACT PROVISIONS

Each of the provisions of these Terms and Conditions shall apply to the full extent permitted by law, and the invalidity in whole or in part of any provision shall not affect the remainder of such provision or any other provisions.

34.0 E-VERIFY

E-Verify - I understand that E-Verify is the federal E-Verify program operated by the United States Department of Homeland Security and other federal agencies, or any successor or equivalent program used to verify the work authorization of newly hired employees pursuant to federal law in accordance with NCGS §64-25 et seq. I am aware of and in compliance with the requirements of E-Verify and Article 2 of Chapter 64 of the North Carolina General Statutes. To the best of my knowledge, any subcontractors employed by me as a part of this contract are in compliance with the requirements of E-Verify and Article 2 of Chapter 64 of the North Carolina General Statutes.

35.0 IRAN DIVESTMENT ACT CERTIFICATION

By acceptance of this purchase order, Vendor/Contractor certifies that, as of the date of the purchase order or contract, it is not on the Final Divestment List as created by the State Treasurer pursuant to N.C.G.S. § 143-6A-4. In compliance with the requirements of the Iran Divestment Act and N.C.G.S. § 143C-6A-5(b), Vendor/Contractor shall not utilize in the performance of the contract any subcontractor that is identified on the Final Divestment List.

36.0 UNIFORM GUIDANCE

Contracts funded with federal grant or loan funds must be procured in a manner that conforms with all applicable federal laws, policies, and standards, including those under the Uniform Guidance (2 C.F.R. Part 200).

37.0 NOTICES

Notices to the Parties should be sent to the names and addresses specified below:

Cleve Haddock, CLGPO
Procurement Manager
Greenville Utilities Commission
P.O. Box 1847
Greenville, NC 27835-1847

Appendix B

Standard Distribution Pole Drilling Guide

[Balance of Page Left Blank Intentionally]

DISTRIBUTION

STANDARD DISTRIBUTION POLE DRILLING GUIDE.....DGEC

3			
2			
1			
0	3/15/06	CADD GRAPHICS	OST
REVISED	BY	APPR.	

**TABLE OF CONTENTS – SECTION 4
DISTRIBUTION**



SCALE
NO SCALE

DWG.
TOC_4.0

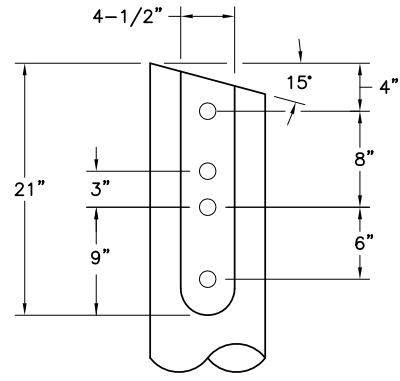
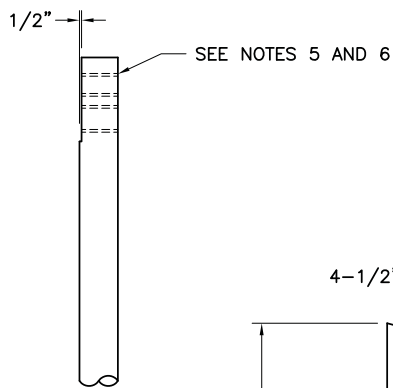
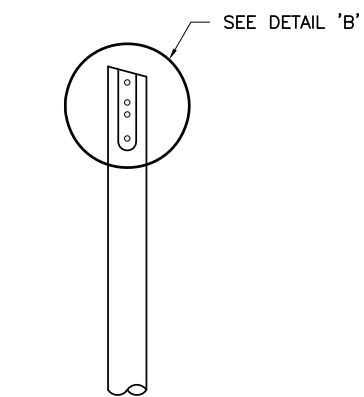

DETAIL 'B'

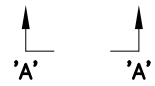
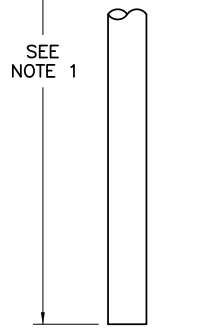
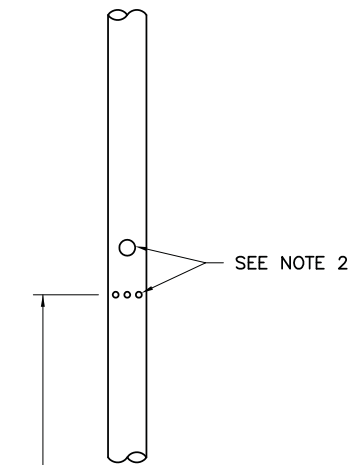

FRONT VIEW

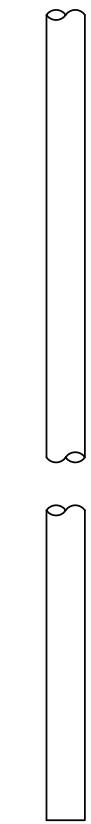

SIDE VIEW

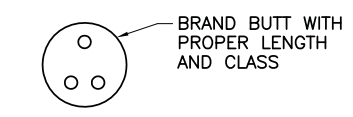

SECTION 'AA'

NOTES:

1. BOTTOM OF BRAND SHALL BE 10'±1" FROM POLE BUTT; 14'±1" MARK FOR POLES 55' AND LARGER.
2. POLE SHALL BE BRANDED WITH LENGTH, CLASS, SPECIES, PRESERVATIVE CODE AND RETENTION. MANUFACTURER MARK AND DATE OF TREATMENT, INCLUDING MONTH AND YEAR, SHALL ALSO BE NOTED.
3. ALL POLES TREATED FULL-LENGTH MUST BE BORED, ROOFED AND GAINED BEFORE TREATMENT. CLASS 7 AND SMALLER POLES NEED NOT BE GAINED UNLESS REQUESTED BY PURCHASER.
4. ROOFS MUST BE AT A 15° ANGLE.
5. THROUGH-BOLT HOLES TO BE DRILLED 11/16" DIAMETER AND MUST BE PARALLEL AND IN THE SAME PLANE.
6. GAINS ARE TO BE FLAT WITH PLANE AND AT RIGHT ANGLES TO BOLT HOLE.

3			
2			
1			
0	3/18/04	CADD GRAPHICS	OST
REVISED	BY	APPR.	

**STANDARD DISTRIBUTION POLE
DRILLING GUIDE**



SCALE
1/4"=1'-0"

DWG.
DGEC