

ADVERTISEMENT FOR BIDS

Sealed proposals will be received in the Office of the Procurement Manager, Greenville Utilities Commission, 401 S. Greene Street, Greenville, North Carolina 27834 until 3:00 PM (EDST) on November 18, 2021 and immediately thereafter publicly opened and read for the furnishing of 800 kW Peak Shaving/Standby Generation System.

Instructions for submitting bids and complete specifications will be available in the Office of the Procurement Manager, Greenville Utilities Commission, 401 S. Greene Street, Greenville, North Carolina during regular office hours, which are 8:30AM – 5:00PM Monday through Friday.

Greenville Utilities Commission reserves the right to reject any or all bids. **Late bids will not be considered.**

Notice to Bidders:

Greenville Utilities Commission is committed to the health and safety of our customers and employees. We are taking the spread of COVID-19 very seriously and continue to monitor the latest Local, State, and Federal guidance.

SECTION I

GENERAL INSTRUCTIONS FOR FORMAL BIDS

RELATED TO THE PURCHASE OF APPARATUS, SUPPLIES,

MATERIALS, EQUIPMENT, LABOR AND BUILD

1.0 NOTICE TO BIDDERS

Sealed bids, subject to the conditions made a part hereof, will be received in the Office of the Procurement Manager, Greenville Utilities Commission, 401 S. Greene Street, Greenville, North Carolina 27834 until 3:00 PM (EDST) on November 18, 2021, the day of opening. Bids submitted in a fax or e-mail in response to this Invitation for Bids **will not be acceptable**.

2.0 STANDARD FORMS REQUIRED

Each bidder must submit a proposal on the enclosed bid forms. **The bid must be signed by an authorized official of the firm. Return only the attached Proposal Form. Do not return the Advertisement for Bids, Instructions to Bidders or Specifications.**

3.0 PREPARATION OF BID

Bids must be in sealed envelopes clearly marked on the outside with the name of the bid and the bid opening date and time. Bid shall be addressed to PROCUREMENT MANAGER, GREENVILLE UTILITIES COMMISSION, 401 S. GREENE STREET, GREENVILLE, NORTH CAROLINA 27834.

4.0 TIME FOR OPENING BIDS

Bids will be opened promptly and read at the hour and on the date set forth in the advertisement in the Office of the Procurement Manager, Greenville Utilities Main Office, 401 S. Greene Street, Greenville, North Carolina. Bidders or their authorized agents are invited to be present.

5.0 BID SECURITY

Each Proposal shall be accompanied by cash, cashier's check, or certified check drawn on a bank insured with the Federal Deposit Insurance Corporation or the Savings Association Insurance Fund, payable to the Owner, in an amount not less than five percent (5%) of the total bid as a guarantee that a Purchase Order, if awarded, will be accepted. In lieu thereof, a Bid Bond may be submitted by the Bidder in an amount not less than five percent (5%) of the total bid.

6.0 PERFORMANCE AND PAYMENT BONDS

6.1 The Successful Bidder shall be required to furnish separate Performance and Payment Bonds executed on the forms bound herein in amounts at least equal to one hundred percent (100%) of the Contract price as security for the faithful performance of this Contract and as security for the payment of all persons performing labor and furnishing materials and equipment in connection with this Contract.

6.2 Performance and Payment Bonds shall be with a Surety company authorized and licensed to do business in the State of North Carolina and shall be for the full Contract sum.

7.0 NC SALES TAX

Do **not** include NC sales taxes in bid figure; however, Greenville Utilities Commission (GUC) does pay sales tax. Sales tax should be added to the invoice as a separate item.

8.0 FEDERAL EXCISE TAX

GUC is exempt from Federal Excise Tax and will issue a Federal Exemption Certificate upon request to the successful bidder.

9.0 EXCEPTIONS TO BE CLEARLY STATED

If bid is not in strict accordance with Section II, "Specifications," bidder must list or note all exceptions **on the Request for Proposal Form**, otherwise, it is fully understood that the successful bidder will furnish equipment and/or materials exactly as specified. GUC reserves the right to accept or reject bids with noted minor deviations from specifications and to determine the lowest responsible, responsive bid from the standpoint of quality, performance, and price.

10.0 EVALUATION AND AWARD OF BIDS

GUC reserves the right to reject any and all bids, to waive any and all informalities, and to disregard all nonconforming or conditional bids or counter proposals. In evaluating bids, GUC shall consider whether the bids comply with the prescribed requirements, plus all alternates or options requested. GUC reserves the right to include or exclude any option or alternative in GUC's opinion is in GUC's best interests. If a bid is to be awarded, it will be awarded to the lowest responsible, responsive bidder whose evaluation by GUC indicates that the award will be in GUC's best interests. Only firm prices will be considered for award of this bid.

11.0 PROMPT PAYMENT DISCOUNTS

Bidders are urged to compute all discounts into the price offered. If a prompt payment discount is offered, it may be considered in the award of the contract.

12.0 NUMERICAL ERRORS

In the case of a discrepancy between a unit price and the extension (the unit price multiplied by the number of units), the unit price governs. In the case where numerical bids are stated both in numbers and in words, the words govern.

13.0 BID WITHDRAWAL

A bidder must notify GUC in writing of its request to withdraw a bid within seventy-two (72) hours after the bid opening, not including Saturdays, Sundays, or holidays. In order to justify withdrawal, the bidder must demonstrate that a substantial error exists and that the bid was submitted in good faith.

14.0 MINORITY BUSINESS PARTICIPATION PROGRAM

GUC has adopted an Affirmative Action and Minority and Women Business Enterprise Plan (M/WBE) Program. Firms submitting a proposal are attesting that they also have taken affirmative action to ensure equality of opportunity in all aspects of employment, and to utilize M/WBE suppliers of materials and/or labor.

15.0 DELIVERY TIME

Delivery time is to be stated and will be considered in the evaluation of bids. Failure by the successful bidder to meet quoted delivery shall be interpreted as non-compliance with these specifications and may be deemed sufficient cause for removal of the manufacturer and/or distributor from our lists as acceptable manufacturers or bidders.

16.0 DELIVERY

Shipments will be made only upon individual releases from a blanket purchase order issued by GUC in accordance with GUC's current needs. Time is of the essence with respect to all deliveries under this Agreement. Delivery of all equipment, materials, or supplies shall be made Free on Board (FOB) GUC Warehouse, 801 Mumford Road, Greenville, North Carolina 27834, unless otherwise specified. The agreed price for such equipment, materials, or supplies shall include all costs of delivery and ownership, and risks of loss shall not be transferred from Provider to GUC until express written acceptance of delivery and inspection by GUC. Delivery hours are between 8:00 AM and 4:30 PM Monday-Friday only. **GUC's purchase order number is to be shown on the packing slip or any related documents.** GUC reserves the right to refuse or return any delivery with no purchase order number or which is damaged. GUC will not be charged a restocking fee for any delivery which is refused or returned.

17.0 CONTRACT PERIOD **TBD**

18.0 MANUFACTURER

Bidder is to specify the manufacturer of items being quoted if applicable.

19.0 QUANTITIES

Quantities specified are only estimates of GUC's requirements. GUC reserves the right to purchase more or less than the stated quantities at prices indicated in the submitted Proposal Form based on our actual needs.

20.0 CONTACT INFORMATION

Questions regarding this bid request should be directed to Cleve Haddock, CLGPO, Procurement Manager, at (252) 551-1533, haddockc@guc.com. **All questions pertaining to the RFB must be received by Tuesday, November 2, 2021.**

21.0 TERMS AND CONDITIONS

The attached Terms and Conditions apply to all purchases made by Greenville Utilities Commission (GUC) and must be considered as part of the bid proposal.

BID BOND

KNOW ALL MEN BY THESE PRESENT, THAT WE _____

as Principal, and _____

as Surety, who is duly licensed to act as Surety in North Carolina, are held and firmly bound unto the Greenville Utilities Commission, Greenville, NC, as Obligee, in the penal sum of _____

_____ DOLLARS (\$ _____) (5% Bid Bond), lawful money of

the United States of America, for the payment of which, well and truly to be made, we bind ourselves, our heirs, executors, administrators, successors and assigns, jointly and severally, firmly by these present.

SIGNED, Sealed and dated this _____ day of _____, 2021.

WHEREAS, the said Principal is herewith submitting a Proposal for

800 kW Peak Shaving/Standby Generation System.

and the Principal desires to file this Bid Bond in lieu of making the cash deposit as required by the bidding documents contained herein;

NOW, THEREFORE, THE CONDITION OF THE ABOVE OBLIGATION is such that if the principal shall be awarded the Purchase Order for which the bid is submitted and shall accept the Purchase Order within ten (10) days after the award of same to the principal, then this obligation shall be null and void; but if the principal fails to so accept such Purchase Order as required by the bidding documents contained herein, the Surety shall, upon demand, forthwith pay to the Obligee the amount set forth in the first paragraph hereof, and upon failure to forthwith make such payment, the Surety shall pay the Obligee an amount equal to double the amount of this Bid Bond as set forth in the first paragraph hereof. Power of Attorney from the Surety to its Attorney-in-Fact is attached hereto.

Principal
By _____ (SEAL)

Corporate Surety
By _____ (SEAL)

PERFORMANCE BOND

Date of Execution:

Name of Principal
(Contractor):

Name of Surety:

Name of Contracting
Body:

GREENVILLE UTILITY COMMISSION

GREENVILLE, NORTH CAROLINA

Amount of Bond:

Project RE:

800 kW Peak Shaving/Standby Generation System.

KNOW ALL THESE MEN BY THESE PRESENTS, That We, the Principal and Surety above named, are held and firmly bound unto the above named Contracting Body, hereinafter called the Contracting Body, in the penal sum of the amount stated above the payment of which sum well and truly to be made, we bind ourselves, our heirs, executors, administrators, and successors, jointly and severally, firmly by these presents.

THE CONDITION OF THIS OBLIGATION IS SUCH that whereas the Principal entered into a certain Contract with the Contracting Body, identified as shown above and hereto attached.

NOW, THEREFORE, if the Principal shall well and truly perform and fulfill all the undertakings, covenants, terms, conditions, and agreements of said Contract during the original term of said Contract and any extensions there of that may be granted by the Contracting Body, with or without notice to the Surety, and during the life of any guaranty required under the Contract, and shall also well and truly perform and fulfill all the undertakings, covenants, terms, conditions, and agreements of any and all duly authorized modifications of said Contract that may hereafter be made, notice of which modifications to the Surety being hereby waived, then, this obligation to be void; otherwise to remain in full force and virtue.

IN WITNESS WHEREOF, the above bounded parties have executed this instrument under the several seals on the date indicated above, the name and corporate seal of each corporate party being hereto affixed and these presents duly signed by its undersigned representative, pursuant to authority of its governing body.

Executed in five (5) counterparts.

(Proprietorship or Partnership)

ATTEST: _____

By: _____

Title: _____
(Corporate Secretary or Assistant Secretary, Only)

CONTRACTOR:

(Trade or Corporate Name)

By: _____

Title: _____
(Owner, Partner, or Corporate President or Vice President, Only)

(CORPORATE SEAL)

SURETY COMPANY:

Witness: _____

By: _____

Title: _____

(Attorney-in-Fact)

Countersigned:

N.C. Licensed Resident Agent

(SURETY SEAL)

(Name and Address – Surety Agent)

Surety Company Name and N.C.
Regional or Branch Office Address

**GREENVILLE UTILITIES COMMISSION
GREENVILLE, NORTH CAROLINA
SPECIFICATIONS AND BID DOCUMENTS
FOR A
800 kW PEAK SHAVING/STANDBY GENERATION SYSTEM**

TECHNICAL SPECIFICATIONS

1.0 Scope

The purpose of this document is to detail the technical specifications and requirements for a 800 kW peak shaving/standby generation system. The 800 kW peak shaving/standby generation system will be a complete turnkey design-build project. The generator engines will be fired by 100% natural gas. The work shall include the furnishing of all materials, equipment, installation, testing and commissioning of equipment. The system shall consist of one or multiple generators. The project design shall incorporate means for potential future expansion of additional peak shaving/standby generation

The 800 kW peak shaving/standby generation system will be sourced from a 15 kV 1/0 underground feeder and connected to a 1,000 kVA (277/480 grounded wye) step up transformer.

These Technical Specifications cover the design, manufacture, delivery, installation, testing and commissioning in good order of a new 800 kW Peak Shaving/Standby Generation System at the property of Greenville Utilities Commission, 711 Utility Way, Greenville, North Carolina (See Appendix A [Bid Schedule], and Appendix C [Map]).

The Materialman shall erect the engine-generator(s) and generator switchgear(s), control house (if required) plus provide and install wiring for power and controls. The Materialman shall also provide all miscellaneous hardware, electrical connectors, conduits, conductors, control cables and ancillary equipment for a complete project.

The work shall include furnishing all materials, supervision, labor, tools, equipment, and supplies necessary for the complete installation of the electrical generation system as shown or called for in the Drawings and/or Specifications.

The Bid Schedule includes the complete installation of the Peak Shaving/Standby Generation System and its ancillary equipment. The Materialman shall install the engine-generator set; silencer and exhaust system; control and protection switchgear; outdoor sound attenuated weatherproof enclosure; steel reinforced concrete foundations, fuel connections, fuel storage tanks (if applicable) or other fuel related systems as may be required. The Materialman is responsible for site preparation, foundation design, unloading and installing the engine-generator set and switchgear, service power and control wiring between the engine-generator and switchgear, power wiring throughout

enclosure, and providing, installing, and terminating 480V power conductors, and control cables between the engine-generator/switchgear/utility transformer,.

1.1 Bids will be received on one (1) schedule for the Peak Shaving/Standby Generation System consisting of:

- 1.) A complete 800 kW peak shaving/standby natural gas engine-generator system. The generator system shall be 0.80 pf peak shaving/standby rating with auxiliary equipment including manufacture, delivery, installation, testing, and commissioning. The system shall consist of one or multiple generators with nameplates no larger than 800 kW each.
- 2.) The supply and installation of control and protection switchgear(s) in a self-contained weatherproof enclosure. (Switchgear may be located in the Generator Enclosure, alternatively). This includes recommended relay settings, developed by the Materialman, for all generator protective relays listed in the Specifications
- 3.) The supply and installation of an outdoor, sound attenuated weatherproof enclosure(s) of formed steel or aluminum construction for the generator complete with steel reinforced concrete foundation.
- 4.) Site work associated with the installation of the new generator.
- 5.) Labor

1.2 These Specifications require that the Materialman provide a ten-year warranty on all equipment. The Materialman shall offer a deduction from the Bid Price for reducing the warranty time to one-year.

1.3 Bidder shall indicate lead time for materials and a project completion timeline on the Bid Schedule.

2.0 General Conditions

2.1 All materials and equipment shall be new.

2.2 These Specifications describe the type, size, and characteristics of the various materials and equipment required to be furnished.

2.3 Strict adherence to these Technical Specifications is requested to facilitate checking and consideration of the Proposal.

2.4 Proposals shall include the following:

2.4.1 Catalog numbers, manufacturer, ratings, characteristics, types, etc., of all materials and equipment included. A simple statement that all necessary materials and equipment will be furnished is not satisfactory.

2.4.2 The Bidder shall state in his Proposal the manner in which the equipment will be shipped.

2.4.3 Price shall include the cost of delivery and installation.

2.5 It is the intent of these Technical Specifications that the Peak Shaving/Stand-By Generation System shall be complete and fully operable. Details not mentioned in

the Specifications but required for satisfactory operation shall be furnished and installed by the Materialman.

- 2.6 It is the intent of these Drawings and Specifications that all electrical, mechanical, hydraulic, natural gas, and pneumatic interconnections among separate parts of the Peak Shaving/Standby Generation System be furnished and installed by the Materialman, except where clearly stated that a specific responsibility lies with others.
- 2.7 All construction shall be performed in a workmanlike manner and shall conform to the Drawings and Specifications. The installation shall conform to the latest editions of the National Electrical Code, North Carolina Building Code, National Electric Safety Code, and National Fire Protection Association Codes.
- 2.8 The Drawings and Specifications are complementary, one to the other. That which is shown on the Drawings or called for in the Specifications shall be as binding as if both called for and shown. The intention of the Drawings and Specifications is to include all labor, materials, transportation, equipment, and any other items necessary to do a complete job.
- 2.9 Where the Materialman fails to make efficient use of materials which may be furnished by the Owner and where said failure results in waste or unnecessary use of materials, the Materialman will be liable to replace such waste and to furnish such additional materials as may be required due to unnecessary use.
- 2.10 If any Owner-furnished equipment or materials are lost or stolen, the Materialman agrees to pay the Commission the reasonable cost of replacing the missing equipment and materials.
- 2.11 In such cases where the nature of the work requires clarification by the Commission, such clarifications shall be furnished by the Commission with reasonable promptness by means of written instructions or Detail Drawings or both. Clarifications and Drawings shall be consistent with the intent of Contract Documents and shall become a part thereof.
- 2.12 Within ten (10) working days after the award of the Contract, the Materialman shall submit for approval a complete list of those items of materials and equipment he is required to furnish for the installation. The list shall include manufacturer names, catalog numbers, and catalog data sheets.
- 2.13 A minimum of twenty (20) working days before commencement of work, the Materialman shall submit detailed Drawings and Specifications for all fixtures and equipment items complete with all physical, mechanical, and electrical data. This submittal shall include drawings of all foundation designs complete with dimensions, steel reinforcing, and elevations shown. A conduit stub-out plan shall also be included.

All submittals shall be formal and complete and shall include a cover letter or transmittal with five (5) prints. All submittals shall be made to John Powell, Substation Engineer, 3355 NC Highway 43, Greenville, North Carolina 27834.

The submittals shall bear the stamp of approval of the Materialman as evidence that the Drawings and materials have been checked and considered satisfactory to the Materialman.

The review and approval of the Materialman's submittals does not relieve the Materialman of the responsibilities for errors, omissions, and deviations from the specified requirements and incidental work required for proper operation, equipment failure, function, and space requirements.

- 2.14 Materialman shall be responsible for laying out work. The Materialman shall, immediately upon entering project site for purpose of beginning work, locate all general reference points and take such action as is necessary to prevent their destruction, lay out his own work, and be responsible for any error resulting from his failure to exercise such precaution.
- 2.15 The Materialman shall provide such temporary structures as required for proper storage of materials and equipment. The Materialman shall also provide a temporary electrical lighting and power distribution system of adequate size to properly serve the project. Work shall be installed in a neat and safe manner in accordance with the National Electric Code Article 305 and OSHA.
- 2.16 The Materialman shall comply with all applicable laws and regulations governing this work. The Materialman shall comply with Chapter XXXIII, Section 3304 "Safeguards During Construction," contained in North Carolina Building Code.
- 2.17 The Materialman shall be responsible for obtaining and paying for all permits, licenses, certificates, inspections, etc., required for the peak shaving/standby Generation System, both permanent and temporary. Permits required by the North Carolina Utilities Commission or environmental regulatory agencies are excluded from this requirement.
- 2.18 Insurance

The Materialman shall maintain in full force and effect, the following types of insurance with the coverage's indicated:

- (a) Workman's Compensation Insurance in the statutory amount.
- (b) Comprehensive General Liability Insurance of not less than \$1,000,000 each occurrence and \$3,000,000 aggregate, including Comprehensive Broad Form Endorsement, with Contractual Liability Coverage.
- (c) Automobile Liability Insurance of not less than \$250,000 per person, \$500,000 per occurrence bodily injury and \$100,000 property damage.

The Materialman shall furnish a notarized certification of the appropriate insurance and said certification shall contain the following express language: "This is to certify that the policies of insurance described herein have been issued to the insured for whom this certificate is executed and that these policies are in force at this time. In the event of cancellation or material change in a policy

affecting the certificate holder, thirty (30) days written notice will be provided to the Commission.”

2.19 Correction of Work Before Final Payment

Any work, materials, or other parts of the work that have been condemned or declared not in accordance with the Contract by the Commission shall be removed from the work site by the Materialman and shall be immediately replaced by new work in accordance with the Contract at no additional cost to the Commission. Work or property of others or the Contractor which is damaged or destroyed by virtue of such faulty work shall be made good at the expense of the Materialman whose work is faulty.

Correction of condemned work described above shall be commenced within twenty-four (24) hours after receipt of notice from the Commission and shall be pursued to completion.

2.20 Aftersale Product Support/Warranty

Equipment furnished under these Specifications shall be guaranteed against defective parts and workmanship under terms of the manufacturer's and vendor's standard warranties. In no event shall the warranty be for a period of less than ten (10) years from date of initial startup of the system; and it shall include 100 percent of the cost of parts, labor, and travel time for necessary repairs at the job site.

All repair work shall be completed as promptly as possible under the circumstances prevailing at the site. Response time to an emergency-breakdown call and receipt of spare parts shall be within 24 hours or less.

The ten-year warranty described above shall apply to all equipment provided.

3.0 Standards

All equipment and materials covered by these Specifications and all tests applied thereto shall, unless otherwise stated herein, be in accordance with the applicable provisions of the latest editions of the standards of the ASTM, ANSI, AEIC, NEMA, ASME, IEEE, NESC, NFPA, NEC, and UL.

All equipment and materials shall conform to the latest emission standards or requirements of the Environmental Protection Agency (EPA), The North Carolina Department of Environmental Health and Natural Resources (DEHNR), and local authorities having jurisdiction.

When the term “Standards” is used in the Specifications, it shall be understood to refer to the above Standards.

4.0 Drawings and Instruction Books

4.1 Preliminary Drawings

Before proceeding with fabrication, the Manufacturer shall submit for approval sufficient Drawings to demonstrate that all parts conform to the requirements and

intent of these Specifications. The Drawings shall include five (5) copies each of Enclosure, Steel Reinforced Foundations, Conduit Plan, Panel Connection, Elementary, Control Wiring Drawings, communication block diagrams with point list and a complete list of materials. Drawing sheet sizes shall be 24" x 36" unless otherwise approved by the Commission. Approval Drawings shall be submitted directly to John Powell, Electric Substation Engineer. The Outline Drawings shall show dimensions and location of all equipment as well as dimensions of the switchgear. The material list shall include a complete description of all items furnished including quantity, catalog numbers, ratings, manufacturer, and nameplate. Any manufacturing or parts procurement that occurs prior to approval by the Commission of the manufacturer's drawings is at the risk of the Materialman for correction at his cost to conform to the final approved design. Approval of Drawings shall not be held to relieve the Manufacturer of his obligation to meet all requirements of the Specifications, of his responsibility for correctness of the Drawings, or of his responsibility to meet the original shipping date on the basis of the Commission being allowed two (2) weeks for approval.

All Drawings, or groups of Drawings that always remain together, shall be labeled: " Operations Center - 800 kW Peak shaving/standby Generation System."

4.2 Final Drawings

The Manufacturer shall furnish five (5) copies of each of the following Drawings and Material. Drawing sheet sizes shall be 24" x 36" unless otherwise approved by the Commission. In addition, an electronic copy of all final drawings shall be provided in the Autocad 2014 format on CD-ROM or available for download from a ftp site.

- a. Outline and Assembly Drawings.
- b. Panel Connection Diagram showing exact connections for all components furnished.
- c. Elementary and Control Wiring Diagrams.
- d. Instruction books containing instruction bulletins on all components furnished.
- e. Renewal parts catalog.
- f. Equipment warranties.
- g. Communication block diagrams with point list

All Drawings shall be certified correct and accurately depict the AS BUILT or final condition of all equipment installed by the Materialman and approved by the Commission. All copies of Drawings and instruction books shall be furnished to the Commission for distribution.

5.0 Delivery of Equipment and Shipping

The prices quoted shall include delivery, unloading, and installation of the equipment at the property of Greenville Utilities Commission, 711 Utility Way, Greenville, North

Carolina. The Materialman shall be responsible for securing all permits required for transporting the equipment.

The Materialman shall have a representative on site to receive equipment and material deliveries. The Commission or its personnel will not be responsible for receiving any deliveries. Prior to delivery, Materialman shall give 48 hours notice to: John Powell, Greenville Utilities Commission, 3355 NC Highway 43, Greenville, phone: (252) 551-3388.

Receipt of "Approval Drawings" by the Materialman constitutes authorization for manufacture only, predicated upon the Drawings and corrections found thereon. Any manufacturing or parts procurement that occurs prior to approval by the Commission of the Manufacturer's drawings is at the risk of the Materialman for correction at his cost to conform to the final approved design. Tentative release for shipment is to be granted by the Commission based upon the following:

- a) Ten (10) days prior notification of production testing so the Commission may have a representative present for witness of the tests.
- b) Furnishing of the requested number of copies of the Approved Final Drawings as called for in the Specifications.
- c) Thirty (30) days' notification of tentative shipping schedule and forty-eight (48) hours' notification prior to delivery.

5.1 The Bidder shall state in the Proposal the method by which all equipment will be shipped.

5.2 Before shipment, all equipment shall be completely assembled, wired, and tested for performance of the functions required. Materialman shall provide the Commission with ten days prior notice of performance testing, so the Commission can have a representative present for testing.

5.3 The method of packing and loading shall be such as to protect all parts from dampness, corrosion, breakage, or vibration damage that might reasonably be encountered in transportation and handling.

6.0 Foundation Arrangements

6.1 Materialman is responsible for design and construction of steel reinforced concrete foundations for the engine-generator system, enclosure, generator switchgear(s), 15 kV utility breakers, and generator system control house (if required) that conforms to the site plan. The current transformer will remain in place on the existing pad (Appendix F).

6.2 As part of the Preliminary Drawings, the Materialman shall submit to the Engineer structural foundation designs complete with steel reinforcing. The drawings must be sealed by a Professional Engineer.

- 6.3 Concrete shall have a compressive strength as indicated by the Materialman's foundation design (minimum compressive strength of 4000 psi after 28 days).
- 6.4 All concrete foundations shall extend a minimum of 12" above final grade (i.e. site rocking).
- 6.5 Air entrained concrete shall be used in all applications where concrete will be exposed to moisture and cycles of freezing and thawing. The air content shall be between four percent and six percent (4% and 6%). Air content shall be shown on each truck ticket from the batch plant.
- 6.6 All conduits located beneath any foundation shall be encased in concrete. Conduits to be used by Owner shall be extended one (1) foot beyond the foundation. Materialman is responsible for these one-foot extensions and for arranging conduit stub outs to match requirements of Owner-installed equipment. Suitable additional conduits shall be installed and properly stubbed out from the generator switchgear(s) for future bus and control wiring connections to the future generator switchgear(s) pad. Conduit Plan details should reflect these conduits.

7.0 Conduit Systems

A complete conduit system with associated couplings, connectors and fittings shall be provided for equipment interconnection. Rigid and IMC conduit shall be hot dipped, galvanized, or electro galvanized steel by Allied, General Electric, Republic, Triangle or Wheatland. Conduit, connectors, couplings and fittings shall be UL listed and labeled. PVC conduit shall be Schedule 40, 90 degrees C rated. Associated couplings, connectors and fittings shall be steel as manufactured by Raco or equivalent.

- 7.1 Intermediate metal conduit (IMC) will be used as follows:
 - a. Above ground feeders
- 7.2 Rigid steel conduit shall be used as follows:
 - a. Feeders exposed to severe mechanical damage
 - b. Elbows for emerging underground feeders
- 7.3 Polyvinyl chloride (PVC) shall be used for underground feeders but rigid steel elbows shall be used for all 90 degree bends.
- 7.4 Liquid tight, flexible metal conduit shall be provided for termination at enclosures or skids which are subject to motion and vibration. Conduit shall be electrically continuous. Length shall not exceed 6 feet.
- 7.5 Conduits which enter from outside a structure or building shall be grouted to prevent entry of gases, vapors, insects or rodents.
- 7.6 Conduits shall be mechanically and electrically continuous from cabinet to cabinet pull or junction boxes. A copper ground wire shall be installed as a

jumper around flexible conduit. The jumper may be installed inside of flexible conduit or outside of conduit to assure continuity of ground.

7.7 One spare two (2) inch conduit shall be installed between the generator system control house and each generator and utility breaker (if applicable).

7.8 Any conduit for fiber optic cable shall not include any control or power wiring.

8.0 Outdoor Sound Attenuated Enclosure for Engine-Generator(s)

8.1 General

The Engine-Generator Enclosure shall house the starting system, cooling system, and all other auxiliary equipment required for a complete self-contained generator. The weatherproof enclosure shall be complete in every detail and require no additional in-field modifications or assembly except where specifically allowed by these Specifications. The enclosure shall be accurately dimensioned to be in compliance with the National Electrical Code (NEC) and Occupational Safety and Health Administration (OSHA) regulations for clearance of all specified items included therein and all applicable fire codes for a structure and application of this type. The Materialman shall furnish all materials for the equipment enclosure and detailed instructions for assembly.

8.2 Single Point Connections

Single point connections shall be employed for the natural gas supply, other fuel supplies, crankcase drain, radiator drain, and generator feeder.

8.3 Drawings

Construction Drawings, engineering blueprints, or other bid documents that may be available to show control panels and other service or distribution equipment within the enclosure must be considered complementary to and not in lieu of this written Specification. Drawings submitted for approval shall reflect this fact clearly, and any contradiction or omission shall be brought to the attention of the Commission before bid.

The successful bidder shall submit drawings of the proposed exterior enclosure design for review and approval.

8.4 Construction

The weatherproof enclosure shall be of formed sheet steel or aluminum construction. The design and construction shall be modular in that the side panels, doors, and louvers shall not exceed 36 inches in width. The enclosure roof shall be either a one piece, seam welded, peaked design or a standing seam formed modular panel design. The interior walls and ceiling shall be lined with sound absorbing material and covered with a perforated liner.

All components shall be a minimum thickness of 14 gauge for formed sheet steel and 12 gauge for formed sheet aluminum. The roof of the enclosure shall meet or exceed the minimum gauge requirements specified.

All sheet steel used in the construction of the enclosure shall be hot-dip galvanized after forming the component parts and before final assembly. This sequence of metal forming, hot-dip galvanizing, then final assembly of the enclosure must be noted on the Drawings submitted for approval and a factory certification of this manufacturing process shall accompany the "As-Built" Drawings provided to the Commission.

8.5 Mounting

The outdoor enclosure shall be securely attached to the foundation. As part of the sound attenuation feature a gasketing material must be placed between the enclosure mounting surface and the foundation. Spring type vibration isolators shall be located between the engine-generator package and the sub-base. Provide a full diamond plate steel floor with openings for conduit entrance. Provide lifting eyes on the exterior of the steel base assembly. Pipe all gas, water and fume lines to the exterior of the enclosure. Provide NEC required clearances around all electrical equipment including disconnects and the generator output terminal box.

8.6 Doors

All doors on the enclosure shall be strategically located in areas as to allow ease of maintenance on the switchboard and allow good access to and visibility of instruments, controls, gauges, etc. Each door shall be fitted with flush-mounted, adjustable, key-lock latches and with panic (emergency) bar hardware.

8.7 Louvers

Air intake shall be accomplished by a method necessary to meet the weatherproof and sound level requirements of this specification. All intake louvers shall be provided with bird screen. Relief air shall exit the enclosure through a fixed grille. All louvers shall be designed to prevent the entrance of driving rainwater. Equipment located near louvers shall be protected from rainwater pulled in through louvers during engine operation. Protection may require erection of barrier between air intake louvers and nearby equipment. All louvers for sound attenuated genset enclosures shall be fixed open.

8.8 Components

All components of the enclosure shall be assembled using 0.375-inch (minimum) plated, hot-dip galvanized or stainless steel, bolts, nuts, and lock washers. Cadmium plating will not be acceptable. In addition, watertight neoprene flat

washers shall be used on all roof bolts. All auxiliary devices and accessories shall be installed by the enclosure manufacturer, including gas train, battery charger, lead acid batteries and rack, control panels, isolators, etc.

8.9 Finish

Upon final assembly of the enclosure, and after all welding and fabrication, all steel enclosure components shall be chemically cleaned and primed. After assembly, all seams should be caulked and a final finish of industrial enamel applied at a 2-3 mil thickness. The enclosure shall be painted ASA #61 gray. This finish shall be suitable for outdoor applications.

8.10 Enclosure Sound Abatement Treatment

The Materialman shall provide an enclosure internal sound abatement system that shall limit the total sound pressure level (mechanical and exhaust) at 25 feet from the enclosure to 75 dBA on a free-field basis while the generator is operating at full load condition.

To attenuate low frequency sound radiation through the enclosure foundation, the enclosure shall be furnished with vibration isolation between the enclosure and foundation. The vibration isolation shall be accomplished by using gasket material that is a medium density, closed cell neoprene of adequate thickness to provide the required isolation.

8.11 Supply Sources for Materials and Equipment

All items related to the outdoor enclosure as shown on the Drawings and listed in the Specifications shall be supplied by the Materialman.

9.0 Generator System Control House (If Applicable)

9.1 Material man shall be responsible for the design and construction/assembly of a generator system control house to be erected onsite.

9.2 Control House shall be suitably sized/designed to house the generator system master controller and ancillary communication equipment.

9.3 Material man shall make provisions for the installation of (2) 19" communication racks to be housed in the Control House.

9.4 Control House shall be conditioned space. Material man shall be responsible for installation of appropriately sized HVAC unit.

- 9.5 Materialman shall be responsible for providing 120/240 V service to the Control House from one of the utility transformers.
- 9.6 Materialman shall provide a suitable sized battery bank and dual rate battery charger for operation of utility breakers, and communications equipment. Approved manufacturers of batteries and charger are Storage Battery Systems, LLC and C&D Technologies.

10.0 Engine

10.1 General

10.1.1 Intent of Specifications

It is the intent and purpose of these Specifications to secure for the Commission a 100% natural gas engine as the engine prime mover using a modern commercial design. It shall be capable of continuous service at the specified rating for the duration of any peak shaving/standby interval. The engine shall also be rated for continuous operation at the continuous rating of the generator set. The engine shall be capable of providing generator operation at any of the quoted ratings. The engine shall be new, completely assembled, and tested.

The engine shall be the product of an established engine manufacturer and shall be a basic design that has been manufactured and successfully operated in similar service for a period of at least one year to thoroughly establish its reliability. In addition, engine shall have been installed in at least ten (10) previous installations operating for one year or more. These installations shall have been in stationary engine-generator applications.

It is the intent and purpose of these Specifications to also secure for the Commission the necessary controls and accessories such as electric starting, battery charging alternator, electronic governor, generator voltage regulator, radiator, fan, air cleaners, lubrication oil pump, fuel system, fuel storage, and jacket water pump to the extent that this equipment, in conjunction with the engine-generator set, will comprise a complete operating package for installation 750 feet above sea level in an outside ambient temperature of 105°F maximum when located within the provided enclosure.

Rating

10.1.2

Rating of the engine shall be based on operation of the set when equipped with all necessary operating accessories such as electric starting, battery charging alternator, electronic governor, generator voltage regulator, radiator, fan, air cleaners, lubrication oil pump, fuel system, and jacket water pump.

The engine shall be capable of driving a generator producing the specified peak shaving/standby rating at 0.8 power factor for applications at the ambient and altitude conditions stated.

10.1.3 Reduced-Load Operation

The engine shall be designed to operate continuously at loading levels down to 20 percent of its peak shaving/standby rating without significant loss of efficiency or other operating problems. The peak load shaving rating for this equipment has been selected to provide for unusual load peaks.

10.2 Engine Specifications

10.2.1 Type

The engine shall be a compression or spark ignition engine. It shall be either a four-stroke cycle or two-stroke cycle, solid-injection engine of either vertical in-line or V-type. Total piston displacement volume in cubic inches shall be sized for each specific application.

10.2.2 Horsepower

Horsepower rating shall be capable of producing the required kW rating. Engine manufacturers published curves shall be submitted.

10.2.3 Speed

The engine speed shall be 1800 RPM or less for operation at rated frequency.

10.2.4 Fuel

The engine shall be capable of satisfactory performance on 100% natural gas fuel.

10.2.5 Governor

The engine governor shall maintain isochronous frequency regulation from no load to full-rated load. Steady-state operating band shall be ± 0.25 percent. The governor shall be capable of remote speed adjustment. The governor shall be by Woodward Governor Company.

10.2.6 Oil Pump and Cleaners

The engine shall have a gear-type lubricating oil pump for supplying oil under pressure and full flow. The pump shall be a positive displacement type that is gear driven by the engine gear train and an integral part of the engine. The system shall incorporate full flow filtration with a bypass valve to allow lubrication to continue in the event of unusually high filter restriction. The bypass valve shall be an integral part of the engine filters or filter housings. Bypass valves located in replaceable filter elements are not acceptable. Pistons shall be oil cooled by continuous jet spray to the underside of the piston crown and pin. Oil filters shall be conveniently located for servicing.

10.2.7 Air Cleaners

The engine shall be furnished with one or more dry-type air cleaners.

10.2.8 Starting Motor

The engine shall be equipped with a 24-volt dc electric starting system with positive engagement drive and of sufficient capacity to crank the engine at a speed that will start the engine under operating conditions. The starting pinion will disengage automatically when the engine starts. The starting system shall incorporate an automatically reset circuit breaker for anti-butt engagement.

10.2.9 Jacket Water Heater

An engine-mounted thermal circulation tank-type immersion water heater incorporating an adjustable thermostatic switch shall be furnished to maintain engine jacket water to a minimum of 80°F in a still air, ambient temperature of 30°F. The Materialman shall indicate the set-point temperature for the jacket water heater he proposes to supply. A 120V-1 phase connection shall be utilized to maintain the engine at an acceptable starting temperature.

10.2.10 Engine Instruments

The engine-mounted instrument panel shall contain, as a minimum, the following gauges for proper engine surveillance and maintenance:

Tachometer

Engine water temperature

Engine oil temperature

Engine lube oil pressure

Engine running hour meter

10.3 Battery Set

10.3.1 Sealed Batteries

A sealed lead-acid storage battery set suitable for heavy-duty engine starting shall be provided. Batteries shall be warranted for 36 months in a peak shaving/standby generator application and have a minimum capacity of 244 ampere-hours. Batteries shall be guaranteed for 36 months of operation consisting of 100 engine starts per year.

Engine-starting batteries shall be capable of providing four 30-second starting attempts when applied with the electric starting motor at an ambient temperature of 30°F. Battery rack(s) constructed in conformance to National Electrical Code requirements, necessary cell interconnections, and battery cables shall be provided. Insulated terminal boots and/or covers shall be provided to minimize accidental short circuits.

10.3.2 Battery Charger

A 120 volt dual-rate battery charger shall be provided and powered. The charger shall be located in a NEMA 1 rated cabinet within the generator enclosure, and be equipped with DC ammeter and DC voltmeter. The charger shall be capable of charging a fully discharged battery set to 80 percent of its amp-hour rating in not more than 12 hours. Upon reaching 80 percent, the charger shall automatically switch to float mode and supply whatever current is required to maintain float voltage. The battery charger shall be equipped with separate contacts for “Loss of ac Voltage” and “Loss of dc charging” alarm annunciation.

10.4 Cooling System

10.4.1 Radiators

The engine shall be equipped with a coolant radiator. The radiator system shall be designed to maintain safe engine operation at an outside ambient temperature of 105°F.

Allowance shall be made for temperature rise due to specific 2 engine and enclosure design applications.

The radiator system shall include a cooling water pump of -adequate capability, an expansion tank, fans, motor(s), valves, and all other equipment necessary for adequate performance.

10.4.2 Cooling System Treatment

The engine cooling system shall be pretreated by the engine supplier for the inhibition of internal corrosion. A solution of 50 percent ethylene glycol shall be used.

A barrier between radiator and container walls/roof shall be installed to prevent radiator air recirculation.

A radiator fill access opening shall be provided in the roof of the enclosure.

Engine radiator overflow tube and the fumes disposal tube shall be vented to the exterior of the unit.

A low water level switch shall be installed in the radiator with contacts to activate a low water level fault signal.

Radiator drain shall be routed through a ball valve and short extension to the outside of the enclosure to facilitate proper draining.

The engine cooling system installation shall include all necessary support and attachment materials as well as flexible pipe connections to allow for expansion, contraction, and vibration damping at the engine connection.

10.5 Exhaust System

The engine exhaust shall be vented by means of exhaust piping furnished and installed by the Materialman. The installation shall include all necessary support and attachment materials as well as flexible pipe connections to allow for expansion and contraction of exhaust piping.

The exhaust pipe diameter shall be selected by the Materialman to coordinate with engine and silencer characteristics.

A suitable silencer of the reactive type shall be furnished and installed near the engine. The silencer shall limit the total sound pressure level (mechanical and exhaust) at 25 feet from the enclosure to 75 dBA on a free-field basis while the generator is operating at full load condition. A stainless steel bellows-type exhaust adapter at least 18 inches long shall be furnished at the exhaust outlet on the engine.

Silencer shall be protected by a high temperature corrosion resistant coating. The silencer exhaust port shall be supplied with a 90 degree elbow and rain cap for vertical venting.

The system shall conform to all current EPA requirements regarding Reciprocating Internal Combustion Engines (RICE) such as the National

Emission Standards for Hazardous Air Pollutants (NESHAP) and New Source Performance Standards (NSPS),

10.6 Safety Controls

The generator control system shall be equipped with automatic safety controls that will shut down the engine and make contact for the alarms control panel on the switchgear in the event of the following.

- low lubricating oil pressure
- high jacket water temperature
- engine overspeed
- engine overcrank
- low coolant level
- natural gas leak detected within the enclosure.

10.7 Drains and Disposal

The engine shall have coolant and oil drains outside the unit to facilitate maintenance. Each drain line is to have a high-quality valve located near the fluid source inside the enclosure. The engine shall be equipped with a crankcase ventilation system. The system shall be constructed to vent crankcase fumes outside the enclosure with a means to prevent condensed oil from contaminating the soil.

10.8 Natural Gas Fuel System

The natural gas train shall be an integral part of the package and shall consist of solenoid shutoff valve, gas pressure regulator, and carburetor. The materialman shall install flexible gas piping between each engine(s) and the final regulator(s). The utility natural gas point of delivery (POD)/gas meter will be located at the gen site (see site plan for approximate location). The Commission will provide the natural gas service line, at 60 PSI, according to the BTU requirements of the generation system proposed by the Materialman. The Materialman shall supply the BTU requirements of each genset, plus the total BTU requirements of all gensets under full load conditions to the Commission for properly sizing the natural gas service main to the site. The Materialman will be responsible for installing all necessary and adequate natural gas piping and connections between the generator(s) and natural gas meter. The natural gas piping system installation shall include all necessary support and attachment materials as well as flexible pipe connections to allow for expansion, contraction, and vibration damping at the engine connection. The natural gas system shall be furnished with liquid filled pressure gauge displaying the inlet and outlet pressure in inches of water column at each gas regulator location.

10.10 Auxiliary Components

To ensure proper coordination of all components, auxiliary components for the engine-generator set shall be provided to the Commission by the engine dealer.

10.11 Installation Supervision

The Materialman shall provide crews to unload and place into position all materials, furnished under this Specification. The Materialman shall also be responsible for supervising installation work and electrical wiring work on the furnished equipment.

The manufacturer of the engine shall furnish a field engineer to supervise the labor crew in making the installation. The field engineer shall be used as required to complete the installation in a satisfactory manner.

10.12 Testing

10.12.1 Factory Test

After assembly of the engine and generator on the sub-base with all auxiliary equipment, the entire unit shall be subjected to a full load test. This shall be a four (4) hour full load test at the rated capacity at the rated power factor of 80 percent. During this test, vibration readings shall be taken at all critical points and recorded. Certified test results shall be furnished to the Commission along with the design values for temperature rise, fuel consumption and vibration. These test results shall be furnished in writing one week before shipment of the unit. The Commission shall be given ten-day prior notice of the factory test date and shall be allowed to witness this test.

10.12.2 Field Test

A commissioning plan shall be provided to the Commission, 3 weeks prior to any startup of the engines. The commissioning plan shall include startup procedures for all equipment, SCADA commissioning procedures for each SCADA point, and checklist to confirm completion. Communications to the end devices shall be confirmed before startup of the engines. All startup and commissioning shall be monitored by SCADA. After field installation of all equipment and before acceptance of the installation, the entire unit shall be subjected to a full load test. This test shall be performed at the job site and shall consist of a two (2) hour full load test at the unit's rated capacity and rated power factor of lag 80 percent. The Commission shall be given one week prior notice of the field test date and shall be allowed to witness this test.

The Commission electric system load may be used for this test if prior arrangements are made to confirm that generator problems will not result in interruption of customer's service.

10.13 Supply Sources for Materials and Equipment

The engine and control equipment shall be supplied by an authorized distributor of the engine manufacturer with a full-service organization and spare parts inventory within 125 miles of the job site. The engine supplier shall have in his direct employment factory-trained service technicians and shall be authorized to perform warranty work on all equipment supplied under this section. The equipment supplier shall maintain an around-the-clock, seven-days-a-week emergency service organization with a single emergency telephone number.

10.14 Maintenance Contract

The engine supplier shall furnish a prepaid maintenance contract covering the initial 36 months of operation of the engine. The service contract shall provide for quarterly inspections, annual oil and filter changes, annual adjustment of valves and injectors, or on a more frequent basis as recommended by the engine manufacturer. All labor and materials shall be included as part of the Contract. The maintenance contract shall be transferable to a new owner without penalty or service charge.

10.15 Engine Information to be furnished by Bidder

The Bidder shall furnish the following information with the Proposal:

- a. Drawings of the engine offered hereunder and its foundation requirements.
- b. Literature describing the engine and indicating its current production status.
- c. Drawings and / or literature describing auxiliary equipment to be furnished.
- d. The following data in tabulated form:

Make of engine
Number of cylinders
Bore, inches
Stroke, inches
Piston displacement, cubic inches
Piston speed, feet per minute, at rated RPM
BMEP at rated kW output
Number and type of bearings
State if naturally aspirated, turbocharged, or turbocharged
and aftercooled
HP Prime
HP Standby
Temperature rise at full load

11.0 Generator

11.1 Rating

The generator shall have a Peak Shaving/Standby Rating of 800 kW at lag 80 percent power factor and comply with NEMA MG 1, IEC 60034-1, and British

Standard 4999. The generator shall be designed to generate power at 480/277 volts (nominal), three-phase, 60 Hertz when driven up to 1800 RPM.

11.2 Construction

Generator shall be a brushless, single bearing, close coupled alternator. The generator housing shall mount directly to the engine flywheel housing without bolted adapters. The drive end of the revolving field assembly shall pilot directly into the engine flywheel through flexible steel plates to transmit engine torque. The other end of the revolving field assembly shall be supported by a shielded bearing with grease reservoir. The revolving field assembly shall be balanced to ½-mil peak-to-peak amplitude and be capable of demonstrating 150 percent overspeed capability at 170°C for two (2) hours. Proof of torsional and linear vibration analysis shall be available upon demand to certify compatibility with the engine.

All structure components shall be secured with SAE Grade 8 hardware.

11.3 Windings and Insulation

Class 200 magnet wire shall be used for rotor and stator windings. No materials shall be used that support fungus, growth. All generator insulation material, including power leads, shall be Class F or H with temperature rise in accordance with NEMA standards. However, no temperature rise above 105°C will be allowed.

The revolving field coils will be form wound using square or rectangular magnet wire. Epoxy-based material will be applied to each layer of magnet wire before the next layer is wound. Slot liners and coil separators shall allow no more than 3/8-inch (9.5 mm) distance from the core. The stator windings shall be capable of withstanding up to 2000 volts for phase-to-phase and phase-to-ground faults. The stator will have at least two dips and bakes in epoxy varnish.

Generator windings shall be designed with a 0.667 winding pitch to allow continuous operation in parallel with the utility distribution system. The generator neutral will be solidly grounded for this installation.

11.4 Performance Requirements Under Harmonic Loading

The total harmonic voltage distortion (THD) on the utility bus is estimated to be 5.0 percent or less. However, total harmonic distortion may vary depending on the designated application and in some cases, it may be significantly higher. The generator shall be designed to produce its designated kW rated output under 5.0 percent voltage THD without derating.

11.5 Other Electrical Features

The generator shall be designed to be capable of withstanding, without damage, a momentary 180° out-of- phase connection with the electric utility system.

The successful generator manufacturer shall provide in the submittal data overexcitation capability limits for the machine. This information shall be in the form of a generator damage curve.

The successful generator manufacturer shall also provide Generator data sheets, including all impedances.

As part of the final transmittal drawings, the generator manufacturer shall submit the generator capability curves for operation between lead 0.9 power factor and lag 0.8 power factor. The curves shall show the rated maximum real and reactive-power the generator can supply at various power factors with operation at rated voltage.

The generator shall be designed to operate continuously at rated kW, frequency, and power factor at any voltage not more than 5 percent above or below rated voltage (504 V - 456 V).

The generator shall be protected from overcurrents to comply with the National Electrical Code 2014, Section 445.12 by inherent design.

The three stator leads that connect to the generator electrical output terminals shall be equipped with a set of three (3) current transformers, appropriately sized so that the output is less than 5 amps at full load, C50 relay accuracy, to work in conjunction with the Woodward easYgen-3000 Series paralleling genset controller. For CT placement and ratings, see the One Line Diagram Drawing of the Peak shaving/standby Generation System (Appendix E). All CTs shall be supplied with secondary shorting-type terminal blocks.

11.6 Environmental Protection

The generator shall be designed for resistance to salt- and moisture- laden air to inhibit rusting of internal and external metal parts and the breakdown of winding insulation.

Terminal box sheet metal parts, stator assembly (after winding), rotor assembly non-machined surfaces, castings, and regulator sheet metal components shall be coated with red oxide.

Regulator screws and jam nuts shall be nickel-plated brass.

Aluminum parts shall be corrosion resistant 1100 aluminum alloy where permissible.

Exciter stator and rotor leads shall be covered with heat-shrink tubing.

The generator shall be equipped with 120-volt space heaters to keep internal components dry when the generator is not operating.

11.7 Voltage Regulator

The voltage regulator shall incorporate the following:

100% solid-state components.

Three-phase sensing.

Constant voltage regulation over an engine speed variation of up to 5% of rated; volts-per-hertz performance in transient conditions exceeding 5% engine speed variation.

Torque matched regulators are acceptable.

Steady state voltage drift not to exceed 1%.

Maximum voltage drift over a 40°C ambient change of ±1%.

Response time to load changes not to exceed 20 msec.

Stability over a range of 20% total harmonic distortion (THD) of the voltage waveform as a result of harmonic current.

Telephone Interference Factor (TIF) of less than 50. EMI/RFI shall be suppressed to commercial standards. Protected against overvoltage and overcurrent.

A solid-state circuit to stop excitation if generator overload of 150% of rated power is continuously applied for 10 seconds.

Protection of load and generator against loss of voltage sensing that could result in damaging high voltages.

Undervoltage and underfrequency protection of the regulator.

Sealing against humidity and salt per ASTM-B117 and MIL-STD-810C.

Regulator shall be immune to SCR tracking.

11.8 Main Line Connection

The generator vendor shall furnish bus bars for phase and neutral connections. The generator neutral shall be grounded. Bus bars shall be enclosed in an oversized generator lead box to accept multiple 600V conductors. The generator electrical output terminals will be connected to the generator side of the 480V air circuit breaker located in the supplied switchgear. The Materialman shall supply and install the required power cables to connect between the generator and the generator side of the 480V breaker. The Materialman shall supply and install compression terminals on the power cables and shall make connections to generator leads and generator side of breaker. Size and number of cables shall match those on generator side of breaker.

11.9 Installation Supervision

The Materialman shall provide crews to unload and place into position all materials furnished under this Specification. The Materialman shall also be responsible for supervising installation work and electrical wiring work on the furnished equipment. The generator manufacturer shall coordinate with the engine manufacturer on integration of the two systems.

The manufacturer of the engine-generator shall furnish a field engineer to supervise the labor crew in making the installation. The field engineer shall be used as required to complete the installation in a satisfactory manner.

12.0 Peak shaving/standby Paralleling Switchgear(s)

12.1 General

The Materialman shall furnish utility peak shaving/standby switchgear(s) that provides capability for paralleling the new engine-generators with the electric utility supply.

The installation is intended to remain in continuous parallel operation with the utility system for periods of up to eight (8) hours daily. For this installation the generator neutral shall be grounded.

The switchgear should be designed to facilitate ease of future expansion to incorporate additional peak shaving/standby generators and associated switchgear.

It is the intention of this Specification that the furnished assembly include all devices necessary to provide for all operations described in this section. Any equipment or devices not mentioned in this Specification but required for the specified functional operation shall be furnished and installed by the Materialman.

The Utility Peak shaving/standby Paralleling Switchgear shall be listed under UL-1558.

The Bidder shall furnish evidence that the quoted utility paralleling switchgear has been used successfully in actual commercial service with the generator set quoted by the same Bidder. The submitted evidence shall include location, capacity, in-service date, manufacturer's name for various components, and owner contact information.

12.2 Construction

12.2.1 Free-standing, pad-mounted, outdoor-type NEMA 3R, 277/480 switchgear(s).

12.2.2 Dead front, dead rear.

12.2.3 Switchgear Framework

- a. Fabricated on a die-formed steel base or base assembly welded or bolted together to rigidly support the entire shipping unit for moving on rollers and pad mounting.
- b. Designed to withstand the mechanical stresses caused by rough handling during shipment in addition to the electrical and mechanical stresses that occur during operation of the assemblies.
- c. Framework formed of code gauge steel (12 gauge minimum) suitable for anchorage to pad.
- d. Rugged steel assemblies with bracing, reinforcing gussets, and jig-welding to assure rectangular rigidity. The sections shall be completely metal-enclosed.
- e. Each switchgear section shall have an open bottom as required for ready installation and termination of conduits.

Top and bottom conduit and bus duct area are to be clearly shown and dimensioned on the Shop Drawings.

- f. The completed switchgear assembly shall be mechanically designed to permit lifting and moving of the entire assembly by crane. This feature shall include properly located lifting lugs and auxiliary lifting bars, if required.

12.2.4 All side, top, and rear panels shall be removable, attached by bolts, and small enough for easy handling by one person.

12.2.5 Front doors, hinged, mounted, and equipped with lock-type operating handles, shall be installed throughout for easy access. Half-length or smaller doors will be permitted for the generator circuit breaker cubicle. Layout will be reviewed when shop drawings are submitted.

12.2.6 The switchgear shall be designed for outdoor standalone installation. The Materialman shall be responsible for determining the location and accessibility of the paralleling switchgear within the specified construction area.

12.2.7 Dimensions

- a. Conform to the arrangements, details, and space designated for installation.
- b. Construct so highest operating handles do not exceed 56" above grade level.
- c. Provide adequate gutter space in all sides of switchgear sections. Arrange for clearance to permit good accessibility of conductors and bus ducts into switchgear.

12.2.8 Die-pierce holes for connecting adjacent sections to assure alignment and facilitate future additions:

12.2.9 Bolts, nuts, and washers shall be rustproof metal.

12.2.10 All steel parts shall be prepared for painting by a five step cleaning, phosphatizing, and sealing process. The parts shall then be painted ASA #61 gray, using polyester powder coating applied by the electrostatic method and cured in a baking oven. This finish shall be suitable for outdoor applications.

12.2.11 Suitable means shall be provided near the top and bottom of the switchgear to insure adequate ventilation for all equipment within the switchgear assembly

12.3 Bus Bars and Interconnections

12.3.1 General

- a. All bus and stub connectors shall be copper.

- b. Service entrance rated, 277/480 volts, 3 phase, 4 wire, 60 Hertz. The generator neutral shall be grounded for this installation.
 - c. The size shall be such that the current density is not greater than the current-carrying capacity of the rectangular copper bars as required by UL and NEMA standards. Heat rise tests shall be in accordance with UL 1558.
- 12.3.2 Bus and stub connections shall be designed to limit temperature rise to 30°C at load current capacity in a 40°C ambient environment.
- 12.3.3 The bus shall be insulated so when the rear panel of a vertical section is open, the only exposed energized bare parts will be the load terminals of the generator breaker.
- 12.3.4 Bus bar and interconnection joints shall be silver-plated, constant-high-pressure type with Grade 5 steel bolts, nuts, and compression washers.
- 12.3.5 Bus bracing shall be 100,000 amperes or greater.
- 12.3.6 The ground bus shall be rated at a minimum of 25 percent current-carrying capacity of the main breaker bus and shall extend across the entire width of the switchgear assembly. The ground bus shall have pre-drilled 1/2-inch holes to accept a quantity of 4, NEMA two-hole copper compression terminals, for connection of equipment grounding conductors from generator ground bus and for connection of bonding conductor from switchgear ground bus to switchgear neutral bus. Location of the holes shall be clearly marked on the drawings.
- 12.3.7 Main bus bars for the generator breaker shall be located within the switchgear so as to permit maximum conduit and wiring areas.
- 12.3.8 The bus connections to the power circuit breaker shall match the breaker frame size.
- 12.3.9 The control sections shall be isolated by steel barriers from the circuit breaker and bus sections.
- 12.3.10 All bus work shall be installed in rear compartments.
- 12.4 Instrument and Control Wiring
 - 12.4.1 Instrument and control wiring within the switchgear sections shall be of flame-retardant, Type SIS, No. 14 gauge stranded copper, minimum, approved for switchgear use.
 - 12.4.2 All wiring to equipment and devices mounted on hinged doors and/or panels shall be extra flexible copper, stranded type.

- 12.4.3 Wire terminations at meters, relays, and other similar devices shall be made with ring-tongue or cup-washer terminals.
- 12.4.4 All wiring between shipping sections shall be installed by manufacturer. Wiring shall be disconnected at one end for shipping.
- 12.4.5 Each internal interconnecting wire shall be identified by a suitable permanent marker at each end. Wire numbers shall match the manufacturer's interconnection Drawing.
- 12.4.6 Terminal blocks shall be supplied and clearly marked for wiring that will be installed or reconnected by the Materialman, including wiring between shipping sections.
- 12.4.7 Terminal blocks for terminating current transformers shall be shorting type, General Electric EB-27 or equal.
- 12.4.8 Control circuit fuse blocks shall be rated at 30A, 250V, Class H, barrier type, phenolic or thermoplastic, screw type terminals and lock washers, with spring reinforcing clips.
- 12.4.9 Fuses shall be non-renewable cartridge type with fiberglass tube and shall be sized as required by the respective circuit.
- 12.5 Nameplates
 - 12.5.1 Visible, permanent nameplates shall be provided to identify each instrument, instrument switch, meter, relay, control switch, indicating light, and circuit breaker compartment. Equipment and terminal blocks within the compartments shall also be suitably identified. Relays shall be designated as to use and as to the phase to which they are connected.
 - 12.5.2 Nameplates shall be laminated plastic and attached with bolts. Characters shall be white on a black background.
 - 12.5.3 Nameplate inscriptions will be reviewed and determined when Shop Drawings are submitted for review.
- 12.6 Equipment
 - 12.6.1 The system controls shall use heavy-duty industrial- grade control relays. All synchronizing and failure circuit relays shall embody the fail-safe principle, with dual contacts in parallel within transparent enclosures.

All key-operated switches shall use the same key pattern. All special-function switches shall be keyed switches, equipped with indicating lamps to show the position of each switch.
 - 12.6.2 All CTs shall be at least C50 relaying accuracy class.

12.6.3 The generator circuit breaker shall be a 3-pole, 480V air circuit breaker, stationary mounted type. The power circuit breaker shall be a Cutler Hammer DS Magnum or approved equal

The breaker shall be electrically operated, with a 24V dc shunt trip feature. The breaker shall be equipped with a 24V dc electrically charged stored energy operator, and an anti-pump operating mechanism.

The breaker shall be equipped with a 3-phase, solid-state selective trip unit set for the recommended minimum trip. Overcurrent sensing and tripping functions will also be supplied by utility grade relays located in the Generator Control Cubicle. The breaker shall contain a means for pad locking the breaker in the open position for worker safety. The breaker shall be provided with the necessary number of auxiliary switch contacts for proper operation of the control and protection scheme, plus four (4) additional spare contacts (2 “a” and 2 “b”) for customer use.

12.7 Engine Generator Monitoring and Control Unit(s)

The switchgear shall employ a Woodward Model easYgen-3000 Series paralleling genset controller or approved equal for monitoring and control of the generator set.

12.7.1 The following startup applications will be employed by this unit:

Peak Shave Mode – Start up and maintained parallel operation with the utility. Two conditions should be available with this mode of operation. Connect to an infinite bus with a fixed kW load on the generator or connect to an infinite bus where the kW load is varied on the generator in order to control a process dependent on kW.

Test Mode – Synchronized/Parallel operation at full load without interruption of electricity service.

Crank with No Load- Start up and run without closing in breaker and taking on load.

12.7.2 The following engine control functions will be utilized by the Woodward easYgen-3000 Series paralleling genset controller:

Engine starter control

Fuel solenoid control
Cool down timer
Ramp up/down rate
Load control
Power factor or VAR control

12.7.3 Generator monitoring shall be included as follows:

The Woodward easYgen-3000 Series paralleling genset controller operator interface (HMI) shall be configured to display three phase generator volts, amps, watts, vars, and power factor. Other features shall include:

- a. Indicating device that annunciates the engine is operating in response to a remote load management/peak shaving start signal.
- b. Indicating device that provides an alarm when any of the remote load management control signals have been inhibited.
- c. Start alarm bell or buzzer that sounds for five (5) seconds before an engine start for peak shaving.
- d. Oil pressure monitoring
- e. Water temperature monitoring
- f. Battery voltage monitoring
- g. Speed monitoring
- h. Overcrank monitoring
- i. Start Failure indication

12.7.4 Automatic Synchronizer

An automatic synchronizer function shall be provided for utility paralleling operation with the following features and capabilities:

12.7.4.1 The synchronizer shall become operative when the incoming voltage source reaches approximately 75 percent of nominal. It shall assume control of the engine governing system to rapidly match the frequency and phase of the engine-generator with that of the utility and close the generator breaker with a minimum of system disturbance. Generator breaker closures outside the preset limits shall not occur. Within approximately 1 second after the breaker closure, the synchronizer shall automatically relinquish control over the electronic governor and go into an idle mode.

12.7.4.2 The synchronizer controls shall consist of the following:

- a. A "Phase Window" control to adjust the phase angle acceptable band (approximately $\pm 4^\circ$ to ± 300 for 60 Hz).

- b. A “Sync Time” control to adjust the synchronizer speed to the particular engine-generator/governor combination being used.
- c. A “Gain” control to optimize the synchronizing damping to the particular engine-generator/governor combination being used.
- d. A “Match Up Time” control to allow the phase angle to stabilize within the phase angle acceptance band before Sync relay closure with internal switch, 1/8, 1/4, 1/2 or 1 second selectable.
- e. “Voltage Offset” adjustment to compensate for difference in VT inputs.

12.8 Remote Data Acquisition Status Points and Analog Points

In addition to all control devices described elsewhere in these Technical Specifications, the switchgear control system shall be capable of interconnection to the Commission’s existing SCADA system. The preferred communications medium shall be a local area network connection for intelligent interface to the Woodward easYgen-3000 Series paralleling genset controller, SEL-700G Intertie Protection Relay and other devices that are applicable. The intelligent interface (IED) shall provide access to the following information:

Status Points:

- a. Auxiliary contacts to indicate the position of the generator breaker (52G).
- b. Auxiliary contacts to indicate the position of the utility breaker (52U).(if applicable)
- b. Generator alarms.
- c. Engine control selected position (Manual-Auto-Off-Load Test).
- e. easYgen-3000 or SEL-700G failure alarm.
- f. Battery charger loss of ac, loss of dc charging.
- g. Generator running.
- h. Peak Shave Mode active (feedback from remote Peak Shave control)
- i. Load Test Mode active (feedback from remote Load Test control)

Analog Points:

- a. Delivery Point Power Flow kW
- b. Delivery Point Reactive-Power Flow, kVAR
- c. Delivery Point, Phase A Volts
- d. Delivery Point, Phase B Volts

- e. Delivery Point, Phase C Volts
- f. Delivery Point, Phase A Amps
- g. Delivery Point, Phase B Amps
- h. Delivery Point, Phase C Amps
- i. Generator Output, kW
- j. Generator Output, kVAR
- k. Generator Output, Phase A Volt
- l. Generator Output, Phase B Volts
- m. Generator Output, Phase C Volts
- n. Generator Output, Phase A Amps
- o. Generator Output Phase B Amps
- p. Generator Output Phase C Amps

Control Points:

- a. Engine Run (Crank with No Load)
- b. Test
- c. Peak Shave Mode

12.9 Miscellaneous

- 12.9.1 Furnishing, mounting, and wiring of the controls, except as noted, shall be by the switchgear manufacturer.
- 12.9.2 All solid-state devices shall be capable of withstanding transient voltage surges without damage. To establish conformance with the above, the manufacturer must verify that identical samples have been subjected to the following test.

All power and control terminals shall be capable of withstanding a test voltage of 1500 volts, 60 Hertz to ground for one minute. All elements of the system shall be designed and tested to withstand the test voltage without damage, change, or failure to function properly. Testing at the point of manufacture shall be done in accordance with ANSI/IEEE C37.90-1989.
- 12.9.3 The switchgear shall conform to ANSI/IEEE C37.20.1-1993 and any other applicable standards.
- 12.9.4 The Materialman shall provide the necessary equipment grounding conductors. The use of EMT as a grounding conductor is not acceptable. The Materialman shall terminate all equipment grounding conductors at the switchgear ground bus and shall connect the switchgear ground bus to the switchgear neutral bus

and to the buried grounding conductor located along the perimeter of the genset enclosure. Equipment grounding conductors from the generator ground bus shall be a minimum of 1/0 AWG bare copper with a single grounding conductor in each of the power circuit conduits between the generator and the switchgear.

The Materialman shall furnish uninsulated, two-hole NEMA drilled, copper compression terminals and stainless steel mounting hardware and shall terminate the generator grounding conductors at the generator ground bus and the switchgear ground bus. The generator ground bus shall not be bonded to the generator neutral.

- 12.9.5 The Materialman shall provide the power circuit between the generator bus bars and the generator side of the 480V breaker bus. Conductors shall be Diesel Locomotive Cable (DLC), U.L. listed RHH/RHW

The Materialman shall provide uninsulated, two-hole NEMA drilled, copper compression terminals and stainless steel mounting hardware and shall terminate the generator conductors to the generator phase and neutral bus bars and to the switchgear phase and neutral bus bars.

- 12.9.6 The switchgear manufacturer shall be responsible for providing the coordinating wiring diagrams showing the electrical connections between the switchgear and the engine-generator for use by the electrical contractors and engine-generator service personnel during installation and checkout of the equipment.

- 12.9.7 After fabrication in the switchgear manufacturer's plant, an operational test shall be simulated to check out the entire system before delivery.

- 12.9.8 After installation, the switchgear manufacturer shall provide the services of a competent factory-based service engineer to instruct the electrical contractor and to coordinate the installation. He shall assist in placing the equipment into operation and provide instruction on the operation of the switchgear control system to the Commission personnel designated to operate the equipment.

- 12.9.9 The Materialman shall state the number of field training days that will be provided. The training will include instruction on the operation of the control system and engine-generator set.

- 12.9.10 The switchgear manufacturer shall provide on-site setup, calibration, and testing called for in these Specifications. It is the intent to also provide training to the Commission's operations/maintenance personnel during this time.

The Materialman shall provide recommended settings for all protective relays called for in the Specifications. The typical three phase fault current levels at the site for 480V on the secondary side

of the 1000 kVA (5.75% impedance typical) utility transformer are as follows:

Infinite Bus = 20,943 Amps

The Materialman shall submit all recommended settings to the Commission for review at least one month before scheduled equipment shipment.

A record of each relay setting and calibration results shall be provided to the Commission for each relay and relay function tested. Commission personnel will be present at all testing and shall be instructed as to the proper methods of calibration and checkout of each relay type.

- 12.9.11 The switchgear manufacturer shall maintain a competent factory service organization that is available for service on a 24-hour tall basis.
- 12.9.12 To insure proper coordination of all components, all components shall be provided to the Commission by the switchgear vendor.

13.0 Peak Shaving Paralleling Equipment

13.1 Peak Shaving Signal

The Commission will provide a peak shaving signal as input to the generator control system. The peak shaving signal can originate from a load management switch (contact closure) or a SCADA RTU(via communications protocol). The Materialman is responsible for the control circuits from each of these two sources to the generator control system. Each control circuit shall include an inhibit switch. When either control signal is inhibited, a separate set of contacts shall provide a corresponding alarm indication at the switchgear. For the load management switch, the Materialman shall furnish and install an interposing relay for surge isolation.

13.2 Peak Shaving Operation System Control Circuits

The following detailed peak shaving sequence of operation shall be provided.

- a. A signal from a peak shaving contact, RTU, or the local engine start switch shall set up the circuit to the engine starting control.
- b. For a peak shaving signal from the load management switch or the SCADA RTU, the engine starting shall be delayed for five seconds and an alarm sounded to notify persons prior to engine start.
- c. The engine-generator shall be brought up to 90 percent of rated speed and voltage. A voltage and frequency relay shall be provided to prevent closing of the generator breaker until correct voltage and frequency have been reached.

- d. After the engine-generator has reached rated voltage and frequency, the system shall synchronize with the utility source and close the generator breaker. After synchronizing and paralleling the load shall be assumed by the generator by way of a ramping operation until the kW load remaining at the utility delivery point is zero, or the generator capacity is reached. This action will provide a soft loading transfer to the peak shaving engine-generator set. Under some conditions the total plant load may be less than the generator capacity. Under these conditions the generator shall maintain zero power flow at the utility delivery point by following the existing plant load. The control system shall be able to follow a 4-20mA signal, PT/CT inputs, and digital communications from SCADA for the process control signal. Method of control will be determined based on current equipment located at the site. All methods of control listed above shall be available.

When operating in parallel with the utility, the generator control system shall be capable of maintaining a predetermined power factor between lead 90 percent and lag 80 percent on the generator. While operating in parallel with the utility, the control system shall monitor the voltage on the 480 volt generator bus. If this voltage should at any time exceed a preset level or fall below another preset level, the control system shall take special action to maintain the voltage within the preset limits. This action shall be capable of overriding the interchange controls monitoring the flow between the generator and the utility.

- e. When the start signal from the SCADA RTU, LM switch, or the local control is removed, the engine-generator system shall transfer the load via a ramping operation to the utility source until the load remaining on the engine-generator is at a predetermined minimum level. Then the generator breaker shall be opened, providing a soft unloading transfer to the utility source.
- f. Engine-generator shall continue to run at no-load for an adjustable period from 0-30 minutes before complete shutdown.

13.3 Generator Protection

Generator protection shall be provided utilizing the Woodward easYgen-3000 Series paralleling genset controller. This relay should provide three-phase generator protection for over-voltage (59), under-voltage (27), over-frequency (81O), under-frequency (81U), phase overcurrent (50/51), reverse power (32G), neutral overcurrent (50N/51N), phase balance (47), negative sequence (46), loss of field (40), lockout (86), and sync-check (25). The protective outputs of this relay shall trip the generator lockout relay (86) that will in turn trip the generator breaker.

13.4 Utility Inter-Tie Protection

Utility protection shall be provided utilizing a SEL-700G Intertie Protection Relay. This relay should provide three-phase utility system protection for over-

voltage (59), under-voltage (27), over-frequency (81O), under-frequency (81U), phase overcurrent (50/51), reverse power (32U), neutral overcurrent (50N/51N), phase balance (47), negative sequence (46), loss of field (40), VT fuse loss (60FL), lockout (86), and sync-check (25). The protective outputs of this relay shall trip the generator lockout relay (86) that will in turn trip the generator breaker.

14.0 Communications

14.1 General

- 14.1.1 All programming of devices, physical connections, start-up, and commissioning shall be the responsibility of the materialman.
- 14.1.2 Procurement of all devices shall be the responsibility of the materialman.
- 14.1.3 Bill of materials, with specific model number and part number information shall be included with the preliminary drawings set.
- 14.1.4 A commissioning plan shall be provided to the Commission 3 weeks prior to any startup of the engines. The commissioning plan shall include startup procedures for all equipment, SCADA commissioning procedures for each SCADA point, and checklist to confirm completion. Communications to the end devices shall be confirmed before startup of the engines. All startup and commissioning shall be monitored by SCADA.
- 14.1.5 The Utility RTU shall be a NovaTech Orion LX+, Orion LXm, or Orion MX
- 14.1.6 Approved Ethernet Switch vendors are SEL, Siemens/RuggedCom, and IS5.

14.2 Fiber

- 14.2.1 In locations where 12.47 kV is present, all communications cables that leave an enclosure/house by means of buried conduit, shall be fiber.
- 14.2.2 Short runs between equipment at the same location/site shall be Multimode fiber. All multimode cables will have at a minimum (2) spare fibers, terminated with connectors in a patch panel.
- 14.2.3 Runs that leave a generator site shall be Singlemode fiber. All Singlemode cables will have at a minimum (4) spare fibers, terminated with connectors in a patch panel.
- 14.2.4 GUC will provide a fiber patch panel in which GUC owned fiber will be terminated.

14.2.5 Patch panels will be Corning SPH-01P or equivalent.

14.3 Drawings/Documentation

14.3.1 A block diagram drawing showing communications paths between all devices will be shown. This drawing shall document the following:

- a. Device name
- b. Device ID/Location
- c. Physical Port (DB9/RJ45/Terminal Block etc.)
- d. Type of electrical connection (Ethernet/RS232/RS485 etc.)
- e. Cable Media (Cat5/MM Fiber/Belden XXX etc)
- f. Speed of connection (9600/ 10M/ 1G)
- g. IP address and port
- h. Communication Protocol (Modbus etc.)
- i. Protocol Address
- j. Device Role (Master/Slave/Client/Server etc)

14.3.2 Where multiple connections are present on one physical port, each subsequent connection need only document the Protocol, Address, and Role.

14.3.3 All communications cabling shall be shown on the Electrical Interconnect drawings.

14.3.4 A point list for each connection shall be provided with the following details:

- a. Point Name
- b. Source Address
- c. Source Device
- d. Destination Device
- e. Process Control or Telemetry

14.3.5 Bill of materials, with specific model number and part number information shall be included with the preliminary drawings set.

14.3.6 Device manuals and protocol manuals shall be provided to the Commission in either PDF or paper format.

14.3.7 As-Built drawings will be provided with final point list, cabling, and process control changes documented.

14.4 Point Lists/Communication Scheme/Generator Controls

- 14.4.1 Complete and accurate Communications Points Lists shall be established and documented **before site construction takes place**. Point list shall show source and destination addresses, device addresses, and device role (master/slave). Points used for Process Control shall be highlighted. Point list should be provided in Excel format.
- 14.4.2 Communications between the various devices necessary for process control will be documented fully as per section 14.3
- 14.4.3 Materialman will be responsible for communications between field devices to the Utility RTU.
- 14.4.4 GUC will be responsible for SCADA Master communications to the Utility RTU.
- 14.4.5 All Generator controllers and/or PLC's shall be capable of Modbus, DNP3, or SEL communications with the Utility RTU.
- 14.4.6 All Generator Controls/PLC's must have an Ethernet or serial port with terminal server available to allow connection to GUC's SCADA network. Equipment that can support 2 or more connections (SCADA and Process Control) is preferred.
- 14.4.7 No Data concentrators in the Generator/Transfer Scheme control system will be used to aggregate data for SCADA. . The Utility RTU will function as the data concentrator/programmable logic controller for the site, and can be used for peer to peer Modbus communications if necessary. Any programming or logic that needs to take place outside of the Woodward, SEL 700G, and Utility Breaker Relay shall be done in the Utility RTU, or Generator PLC(if applicable).
- 14.4.8 Preliminary Points list for SCADA Communications (**This list is tentative and is not meant to represent a complete work. It is for informational purposes and is to function as a template.)

Function	Source	Source Address	Destination	Telemetry or PC
Generator Breaker status	Generator Controls	TBD	Utility RTU	Telemetry
Generator Alarms (various)	Generator Controls	TBD	Utility RTU	Telemetry
Generator E-Stop status	Generator Controls	TBD	Utility RTU	Telemetry
Generator Engine Running Status	Generator Controls	TBD	Utility RTU	Telemetry
Main Engine Control Switch Position	Generator Controls	TBD	Utility RTU	Telemetry

Generator Controller Self Check Alarm	Generator Controls	TBD	Utility RTU	Telemetry
SEL Relay Self Check Alarm	SEL Relay	HALARM	Utility RTU	Telemetry
Battery Charger Alarms(various)	Generator Controls	TBD	Utility RTU	Telemetry
Peak Shave Run via LM Switch	LM Switch	TBD	Generator Controls	Process Control
Run with No Load (Test)	Utility RTU	TBD	Generator Controls	Process Control
Run with Load (Peak Shave)	Utility RTU	TBD	Generator Controls	Process Control
OFF	Utility RTU	TBD	Generator Controls	Process Control
Generator KW	Generator Controls	TBD	Utility RTU	Telemetry
Generator KVAR	Generator Controls	TBD	Utility RTU	Telemetry
Generator Volts A	Generator Controls	TBD	Utility RTU	Telemetry
Generator Volts B	Generator Controls	TBD	Utility RTU	Telemetry
Generator Volts C	Generator Controls	TBD	Utility RTU	Telemetry
Generator Amps A	Generator Controls	TBD	Utility RTU	Telemetry
Generator Amps B	Generator Controls	TBD	Utility RTU	Telemetry
Generator Amps C	Generator Controls	TBD	Utility RTU	Telemetry
Generator Hours	Generator Controls	TBD	Utility RTU	Telemetry

14.4.9 Materialman shall provide GUC with licensed software and administrator rights to configure and maintain all PLC's, Controllers and all other electronic devices used on the project. All final configuration files for each controller, PLC, RTU and other electronic devices shall be delivered to GUC.

15.0 Generator Control System Modes and Sequence of Operation

15.1 Peak Shaving Mode

The 800 kW peak shaving/standby generation system shall be designed to operate at its peak shaving/standby rating and 100 percent load factor during peak load shaving periods. During peak load shaving operation, the generator control system will startup, synchronize/parallel with the utility, and shall be capable to become fully loaded to its peak shaving/standby rating within five minutes. The system will maintain output at the maximum engine-generator peak shaving/standby rating for the duration of the peak shaving/standby period (pending available load). The system shall be capable of following a process control signal based on kW and/or kVar.(See section 13.2)

15.2 Standby Mode

In the event of a loss of utility service(voltage), the utility breaker will open and lock out. The generator will start and energize the bus (the gen may have to sync to the bus due to downstream emergency fire pump generator). Upon restoration of utility service for a designated time interval, the generator control system will synchronize/parallel with the utility and close the utility breaker. The utility breaker will perform a sync check prior to closing. Once the medium voltage utility main breaker is closed, the generator control system will gradually transfer load back to the utility and open the generator breaker.

15.3 Impending Storm/Expected Outage/Test Mode

When major weather events are forecasted/expected the generator shall receive a control from SCADA to operate in Test Mode. In this mode, the generator will parallel the utility, and follow the process control signal and take on load. In the event of loss of voltage on the source side of the utility breaker, the generator controls will immediately open and lock out the utility breaker, separating from the utility and generator will begin to operate in standby mode. Feed back to SCADA should indicate that the system is now in Standby Mode, not Test Mode.

15.3 Faulted Bus

In the event of a temporary or permanent fault downstream of the utility breaker, the utility breaker will coordinate with the main utility supply protection settings (substation breaker/system fusing) to clear the fault. The utility breaker's relays will be programmed to lock out after two fault operations. GUC will provide the relay protection settings. The generator control system will not start the peak shaving/standby generators based on the relay seeing a downstream fault condition.

16.0 Utility Breaker

16.1 Procurement

The utility breaker will be provided by Greenville Utilities Commission. Materialman will be responsible for pad, conduits, and setting breaker. Greenville Utilities will install primary cable to the utility breaker and transformer. Materialman will be responsible for all conduit and cable for control cables. Information regarding utility breaker and relay are in Appendix H.

15.3 PT's and CT's

Any additional PT's or CT's needed for the operation of the peak shaving/standby generator system, which are not included by the manufacturer of the utility breaker, are the responsibility of the Materialman. In the event of an omission of any PT or CT from the one line drawing, the Materialman is required to provide any PT's or CT's required for a functional system as outlined in the specification.

17.0 Site Work

17.1 The materialman shall be responsible for all site work/geotechnical engineering associated with the generator site.

17.2 The materialman shall be responsible (if required) for all permitting, erosion control plans, storm water retention plans etc. associated with the generator site.

17.3 Prior to beginning construction GUC will expose and remove the existing ground grid within the project limits.

17.4 Prior to site finish rocking site shall be in good condition, free of debris, and graded. Site shall be free of ruts, excavation, or other abnormal conditions as a result of site construction/equipment.

17.5 Site shall be finished with a 3" layer of Washed 57 Stone on top of a 3" layer of ABC Stone.

18.0 Materialman's Responsibilities

The responsibilities of the Materialman for the installation of the Peak shaving/standby Generation System are as follows:

18.1 Shipment to, unloading, and installation at the designated project site, all items required by these Specifications.

18.2 Site preparation for placement of the outdoor enclosures and utility transformer. If any temporary storage space is required, the Materialman is responsible for coordinating this with the Commission.

- 18.3 Obtaining and paying for all permits, licenses, certificates, inspections, etc., required for the Peak shaving/standby Generation System and/or site construction, both permanent and temporary. Permits that may be required by the North Carolina Utilities Commission or environmental regulatory agencies are excluded from this requirement.
- 18.4 Supplying all design, drafting, engineering, material, work, and supervision to provide a complete and fully operable peak shaving/standby generation system, all in full accordance with Specifications.
- 18.5 Provide a temporary electrical lighting and power distribution system of adequate size to properly serve the project. Work shall be installed in a neat and safe manner in accordance with the National Electric Code Article 305 and OSHA.
- 18.6 Furnishing and installing the exhaust silencer and flexible exhaust connections, exhaust piping, hangers, etc.
- 18.7 Furnishing and installing the engine-generator set, peak shaving/standby paralleling switchgear, and outdoor weatherproof enclosures.
- 18.8 Design and construction of the steel reinforced concrete foundation for the engine-generator set, enclosure, generator switchgear, generator control house, utility transformer and conduits located beneath the foundation.
- 18.9 Furnishing and installing cranking batteries, battery rack, and battery charger. Materialman shall also be responsible for making all connections between the battery charger and cranking batteries.
- 18.10 Providing all materials and installation for engine radiator venting from enclosure.
- 18.11 Furnishing and installing power and control wiring between the generator, switchgear, and utility transformer.
- 18.13 Design and installation of grounding system. Removal of existing substation ground grid within construction limits.
- 18.14 Providing supervision of installation work done by subcontractors.
- 18.15 Furnishing all manufacturer-provided equipment documentation.
- 18.16 Test and verification that protective relays initiate specified protection sequence.
- 18.17 Provide 120/240 volt, Single-phase, service to the engine- generator set enclosure and switchgear.
- 18.18 Supplying, installing and terminating the power conductors between the generator, switchgear, and utility transformer.
- 18.19 Furnishing all documentation and Drawings required by these Specifications.
- 18.20 Furnishing details of all conduit and wiring needed for instrumentation controls and interconnection.
- 18.21 Testing and startup of all components of the peak shaving/standby generation system. Materialman shall have personnel available to make wiring modifications during installation and system checkout.

- 18.22 Calibration and testing of all relays required by Specifications.
- 18.23 Providing recommended settings for all protective relays called for in the Specifications.
- 18.24 Meeting quoted delivery dates on all materials and installation work.
- 18.25 Perform a field test of the complete set installation to include a 2-hour full load test.
- 18.26 Provide warning signs that meet OSHA and NFPA requirements.
- 18.27 Furnishing, installing and testing all natural gas fuel lines between the natural gas meter and generator set.
- 18.28 Disassembly, loading, transportation, and offloading of equipment at to be removed from the site.
- 18.29 Demolition, loading, hauling, and disposal of any foundations that need to be removed for construction.

19.0 Responsibilities of Owner or Others

The Commission or Others will be responsible for the following items related to the Peak shaving/standby Generation System:

- 19.1 Owner shall furnish a site for the peak shaving/standby generation equipment.
- 19.2 Furnishing the Bidder available information pertaining to external equipment with which the system must be interfaced.
- 19.3 Coordinating schedules with the Materialman to arrange time for the Materialman to perform on-site responsibilities.
- 19.4 Furnishing and installing utility padmount transformers.
- 19.5 Furnishing and installing medium voltage cabling to utility padmount transformer.
- 19.6 Furnishing and installing fiber optic cable/control wiring between the substation control house, generator enclosure, step up transformer, natural gas POD, and delivery point
- 19.7 Furnishing Utility RTU for generator to Utility SCADA system communication.
- 19.8 The Commission shall provide metering accuracy CTs, VTs, and a kWh/kW revenue meter at the utility transformer secondary to meter the generator output.

20.0 Liquidated Damages

If Materialman shall neglect, fail, or refuse to complete the work within the time specified, the Materialman shall pay to the Commission, as liquidated damages and not as a penalty, the sum of \$500.00 per day for each calendar day beyond the specified date that the Contractor fails to achieve Substantial Completion for the Project. The project will be deemed substantially complete based on the following criteria.

- A. When the start signals from the SCADA RTU, LM switch, or the local control is applied and the engine-generator has reached rated voltage and frequency, the system shall synchronize with the utility source and close the generator breaker.
- B. After synchronizing and paralleling the load shall be assumed by the generator by way of a ramping operation until the kW load remaining at the utility delivery point is zero, or the generator capacity is reached.

If the Commission shall neglect, fail, or refuse to have their electrical facilities installation complete by an agreed upon date, then the agreed upon completion date for the Materialman shall be extended one day for each day it takes the Commission to complete electrical facilities installation.

Appendix List

Appendix A: Bid Schedule

Appendix B: Approved Bidders List

Appendix C/D: Site Vicinity Map/Site Plan

Appendix E: Site Electrical One-Line

Appendix F: Generator Site Plan

Appendix G: Generator Grounding Plan

Appendix H: Utility Breaker

Appendix A: Bid Schedule

Description	Unit Price	Extended Price
Section I		
Engine/Generator		
Natural Gas Fired Generator		
System 277/480 Volts, 800 kW peak shave/standby at .8 pf, peak shaving rating, auxiliary equipment, silencer & exhaust system, 10-year warranty, testing, and field engineering services.		
Engine Manufacturer: _____	_____	_____
Engine Model: _____		
Engine Description: _____		
Generator Manufacturer: _____		
Generator Model: _____		
Generator Description: _____		
Peak Shaving Rating: _____		
Estimated number of hours before system overhaul for		
Peak shaving Rating: _____	Continuous kW Rating: _____	
Estimated Weeks for Delivery: _____		

Description	Unit Price	Extended Price
Section II		
Utility Peak Shaving Paralleling/Standby Switchgear		
Control and Protection Switchgear, Service entrance rated, including Air circuit breakers, protective Relays, Woodward Control System, Wiring, development of relay settings, calibration, testing, 3-year warranty, Training, and field services engineer:		
	_____	_____
	_____	_____
Switchgear Manufacturer: _____		
Estimated Weeks for Delivery: _____		

Description	Unit Price	Extended Price
Section III		
Outdoor Sound Attenuated Enclosure		
Outdoor Weatherproof, 75 dBA sound attenuated enclosure of formed sheet steel or aluminum construction for engine-generator set, and accessories:		
Total sound pressure at 25 feet: _____	_____	_____
Structure Material being quoted: _____		
Manufacturer: _____		
Estimated Weeks for Delivery: _____		

Description	Unit Price	Extended Price
Section IV		
Site Work		
Site prep, grading, finish rocking, permitting, temporary site lighting, etc.		
Estimated Weeks for Completion: _____	_____	_____

Description	Unit Price	Extended Price
Section V		
Installation and Labor		
Installation and labor for all equipment and materials, including foundations, conduits, wiring and grounding system:		
	_____	_____
Materialman's Subcontractor's and NC State License Number:	_____	# _____
	_____	# _____
	_____	# _____
	_____	# _____
	_____	# _____
Estimated Weeks for Completion: _____		

Bid Summary Price

Section I – Peak Shaving Engine-Generator Set: _____

Section II – Utility Peak Shaving Paralleling Switchgear: _____

Section III – Outdoor Sound Attenuated Enclosure: _____

Section IV – Site Work: _____

Section V – Installation Labor: _____

Total – _____

Total Weeks for Project Completion _____

Deducts:

1-year warranty in lieu of 10-year warranty: _____

5-year warranty in lieu of 10-year warranty: _____

Appendix B: Bidder's List

Gregory Poole Power Systems

Attn: Len Clark

P.O. Box 469

Raleigh, NC 27602

919-890-4608

919-890-4334 Fax

Power Secure

Attn: Robert Tugwell

1609 Heritage Commerce Court

Wake Forrest, NC 27587

919-538-1893

Cummins Atlantic, Inc.

Attn: Kevin Vaughn

350 Cummins Dr.

Kenly, NC 27542

919-284-9111

Crowder Energy Services

Attn: Paul Stephenson

1990 New Cut Rd

Spartansburg, SC 29303

919-367-2033

National Power

Attn: Duncan Leach

4541 Preslyn Drive

Raleigh, NC 27616

919-815-4252

Len Clark
clark@gregpoole.com

Robert Tugwell
RTugwell@powersecure.com

Kevin Vaughn
kevin.vaughn@cummins.com

Paul Stephenson
Pstephenson@crowderusa.com

Duncan Leach
duncan.leach@natpow.com

VICINITY MAP

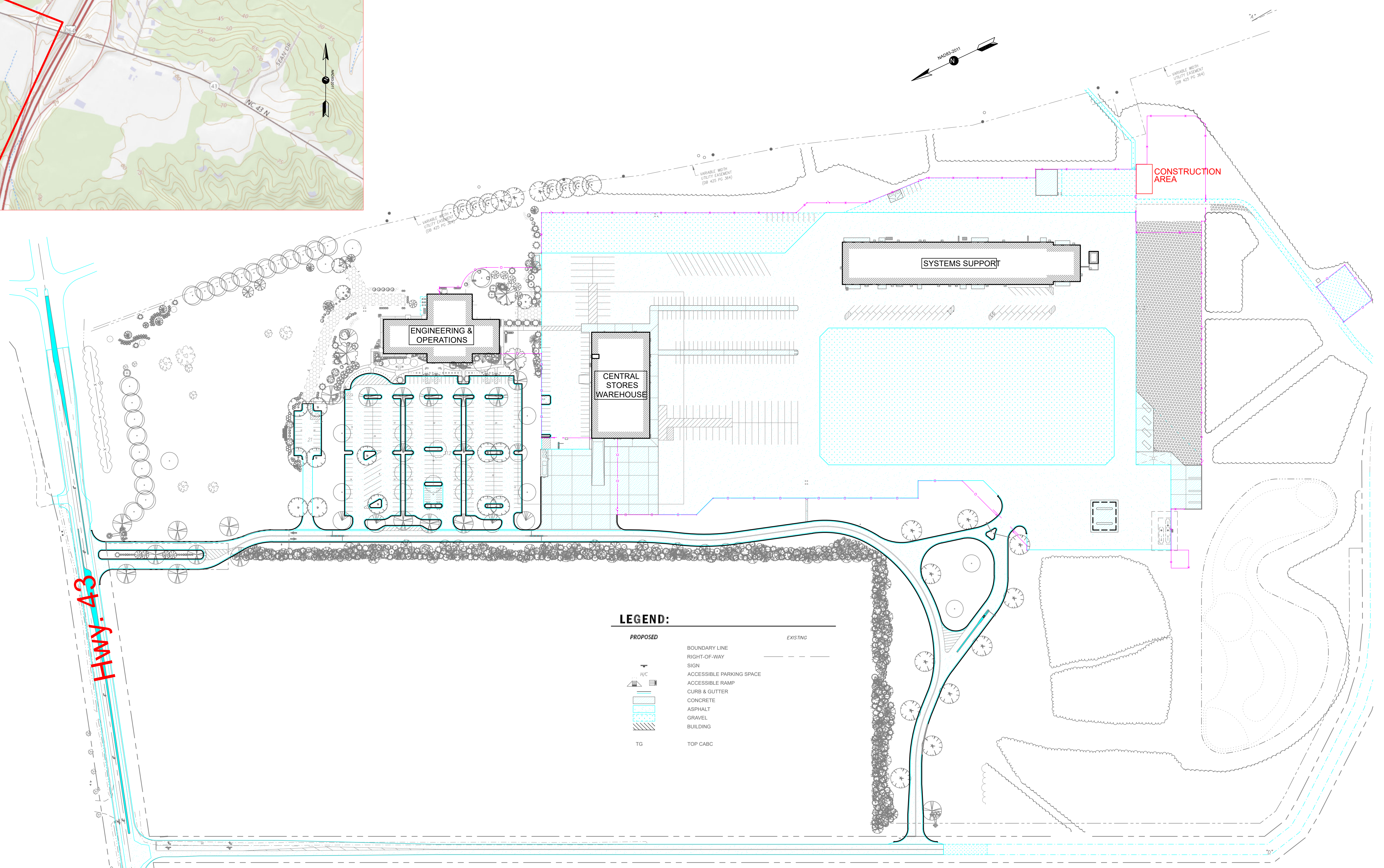
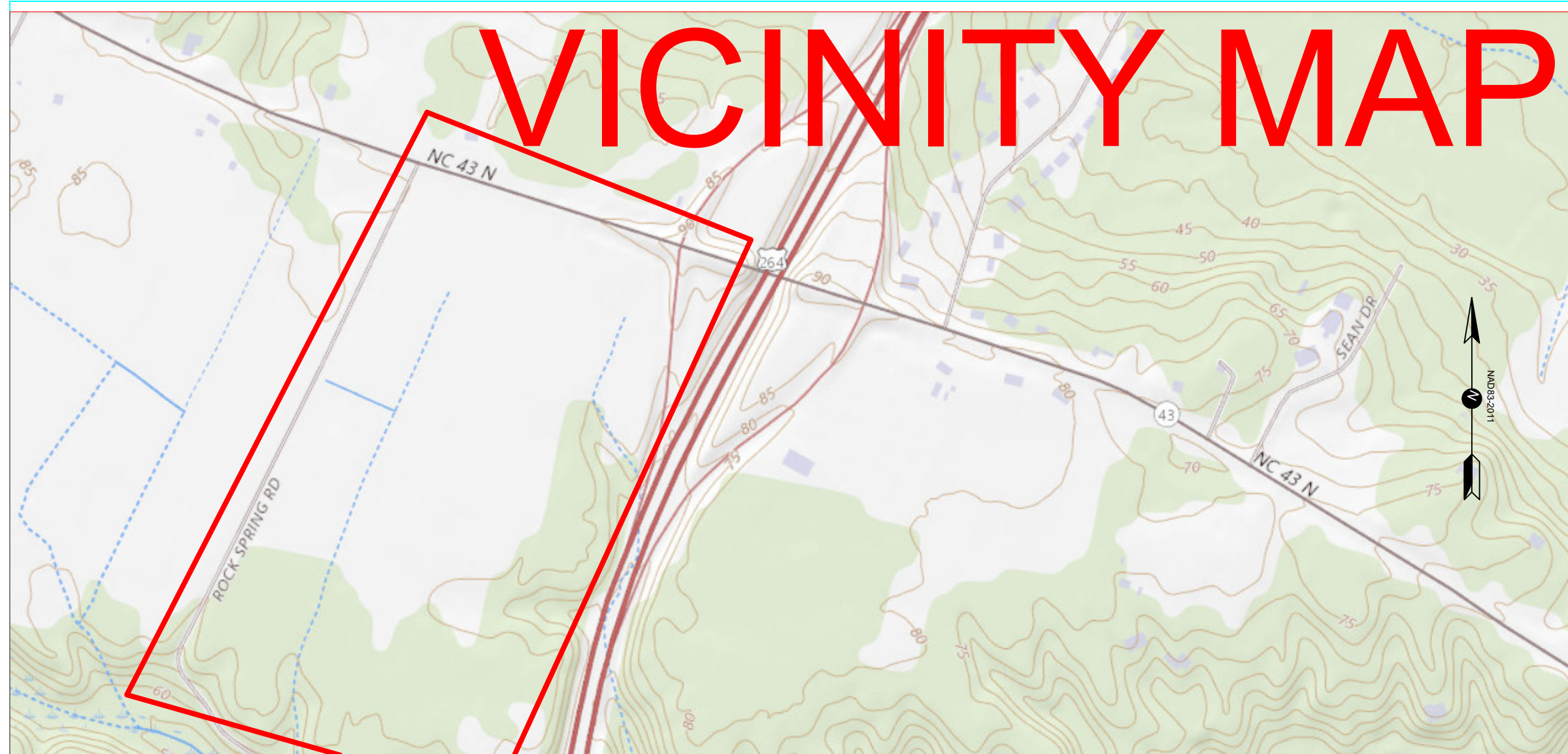

LEGEND:

PROPOSED	EXISTING
—	—
—	---
H/C	
▲	
■	
■	
■	
■	
■	
TG	

NO.	1-A
REVISIONS	OPERATIONS CENTER PEAK SHAVE/ STANDBY GENERATOR PRELIMINARY DESIGN JLP 10/12/21

PRELIMINARY

GREENVILLE UTILITIES Greenville, North Carolina	
OPERATIONS CENTER 800kW PEAK SHAVING/STANDBY GENERATOR SITE VICINITY MAP	
DWN.	DATE
CKD.	APPD.
SCALE: NONE	DWG. NO.

GENERATOR BUS

LOAD BUS

UTILITY BUS

BY MATERIALMAN

BY GREENVILLE UTILITIES

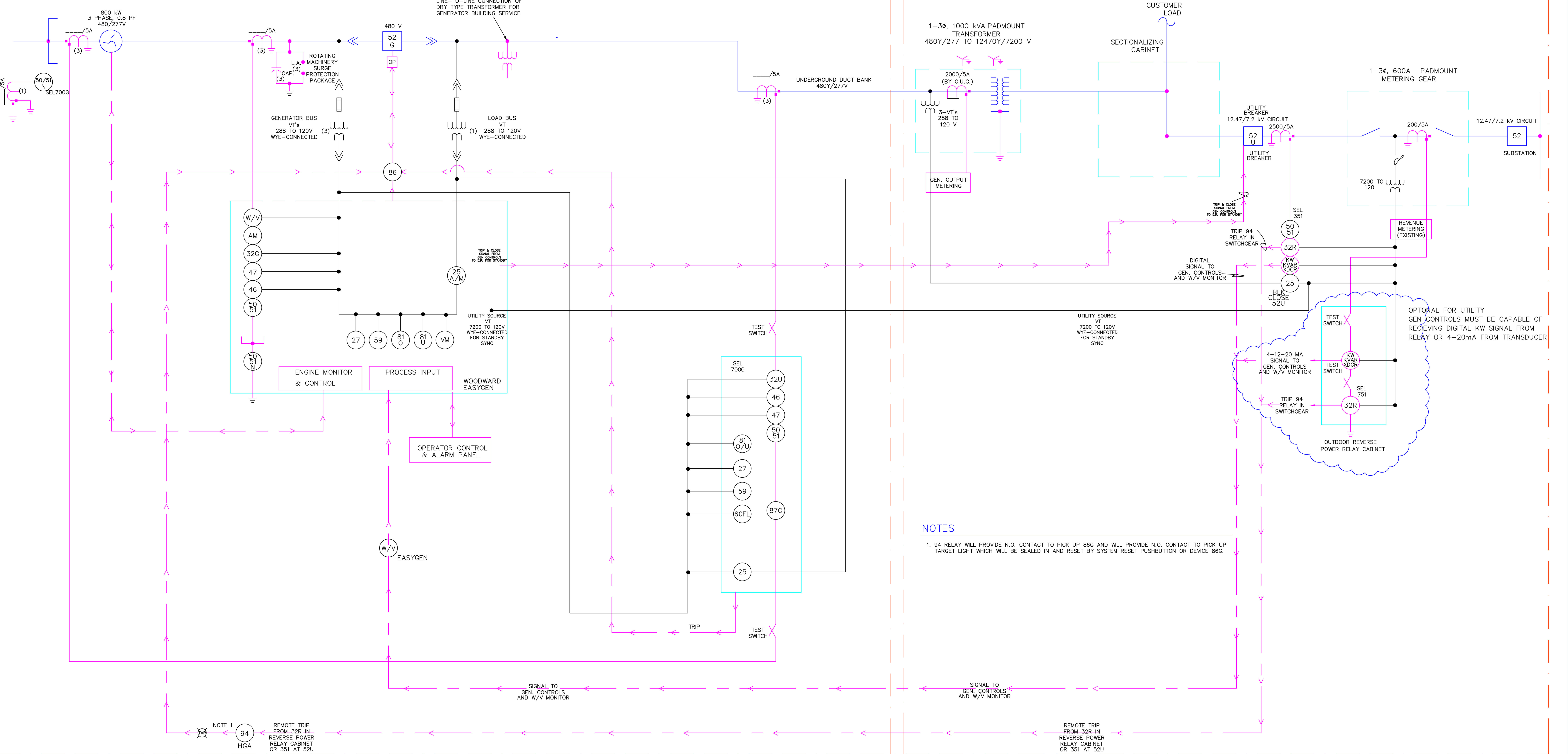

NOTES

1. 94 RELAY WILL PROVIDE N.O. CONTACT TO PICK UP 86G AND WILL PROVIDE N.O. CONTACT TO PICK UP TARGET LIGHT WHICH WILL BE SEALED IN AND RESET BY SYSTEM RESET PUSHBUTTON OR DEVICE 86G.

PRELIMINARY

#	1	2	3A
REVISIONS	OPERATIONS CENTER PEAK SHAVE/STANDBY GEN PRELIMINARY JLP 10/1/21		

GREENVILLE UTILITIES
Greenville, North Carolina

OPERATIONS CENTER PEAK SHAVING/STANDBY 800 kW GENERATOR SITE ONE LINE DIAGRAM

DWN.	DATE	DWG. NO.
CKD.	APPD.	
SCALE: NONE		

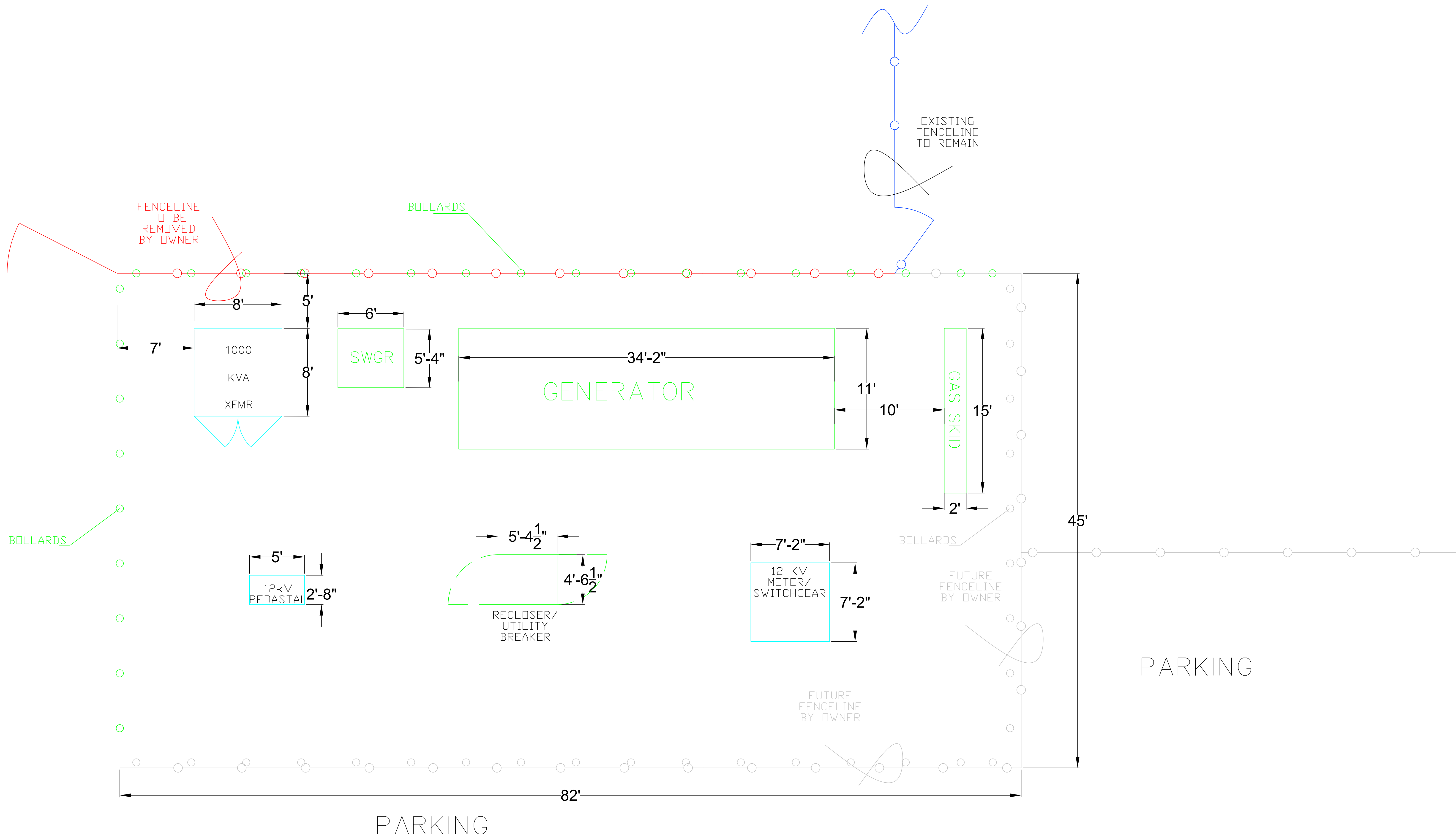

NO.	1.A
REVISIONS	NEW OPERATIONS CENTER SITE STANDBY / PEAKSHAVE GENERATOR PRELIMINARY DESIGN JLP 9/27/21

**PRELIMINARY
ADDITION**

GREENVILLE UTILITIES Greenville, North Carolina		
OPERATIONS CENTER SITE GENERATOR PEAK SHAVE / STANDBY SITE PLAN		
DWN.	DATE	DWG. NO.
CKD.	APPD.	
SCALE: 1/4" = 1' : PRINT AT 1:1		
xxxx_xx_XXXXXX_xxx_R?		

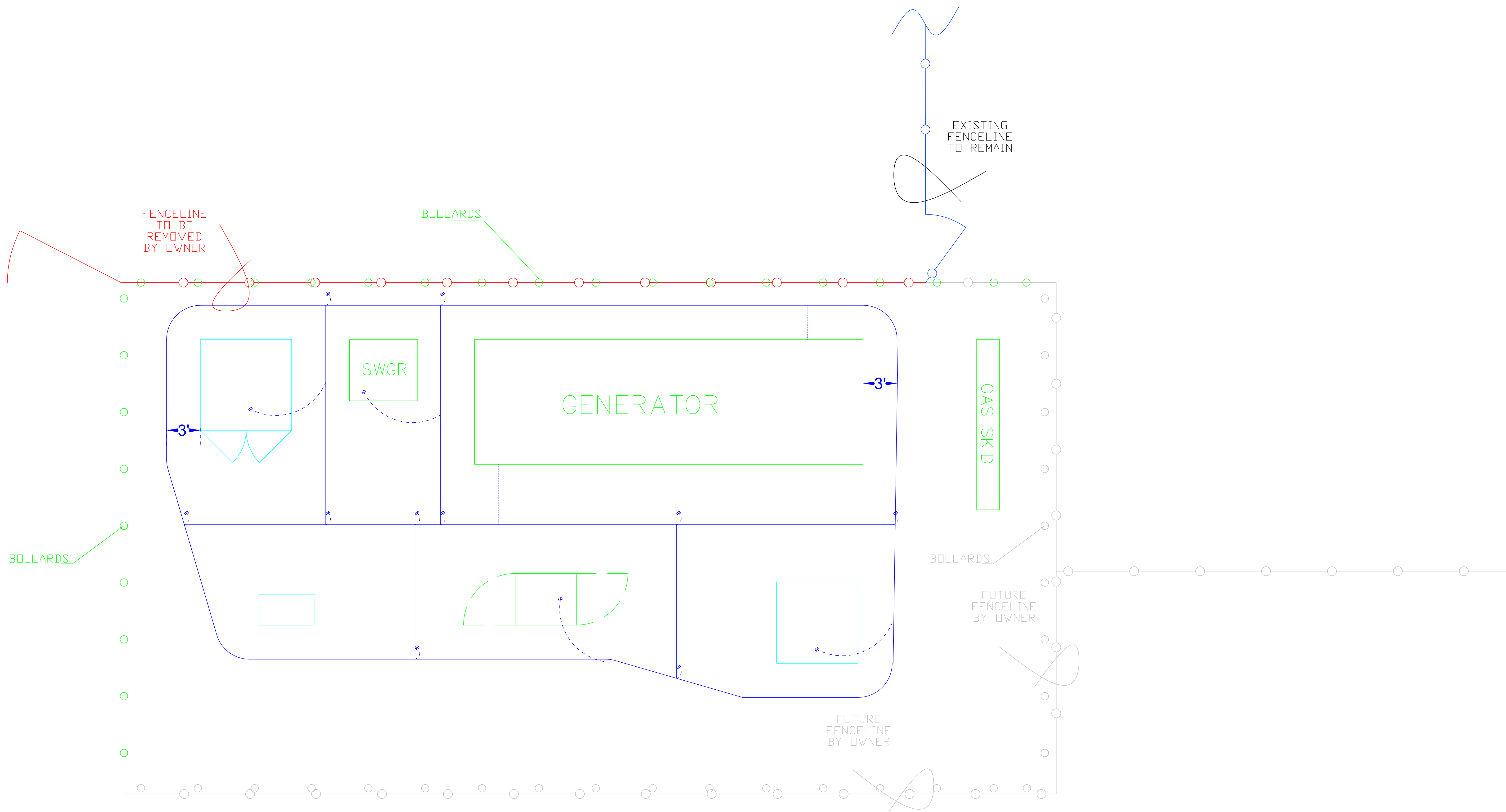

NO.	1.A
REVISIONS	NEW OPERATIONS CENTER SITE STANDBY / PEAKSHAVE GENERATOR PRELIMINARY DESIGN JLP 9/27/21

**PRELIMINARY
ADDITION**

GREENVILLE UTILITIES Greenville, North Carolina		
OPERATIONS CENTER SITE GENERATOR PEAK SHAVE / STANDBY GROUND GRID		
DWN.	DATE	DWG. NO.
CKD.	APPD.	
SCALE: 1/4" = 1' : PRINT AT 1:1		
xxxx_xx_XXXXXX_xxx_R?		

FINAL REVIEW		REVISIONS			
LEVEL	REV.	ECO	ENG	DES	DATE
LEVEL 1	A	307138	CL	CL	8-10-16

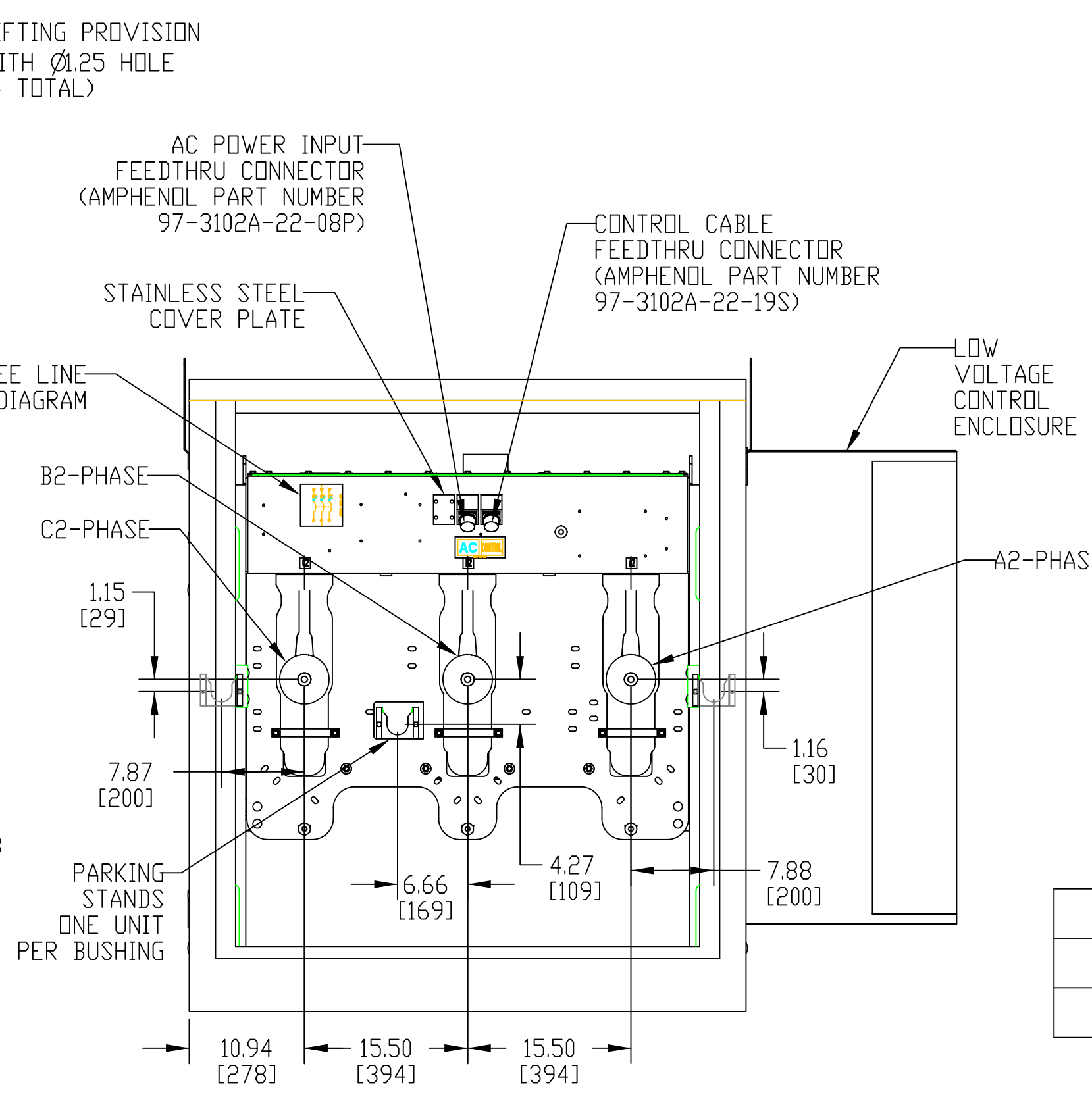
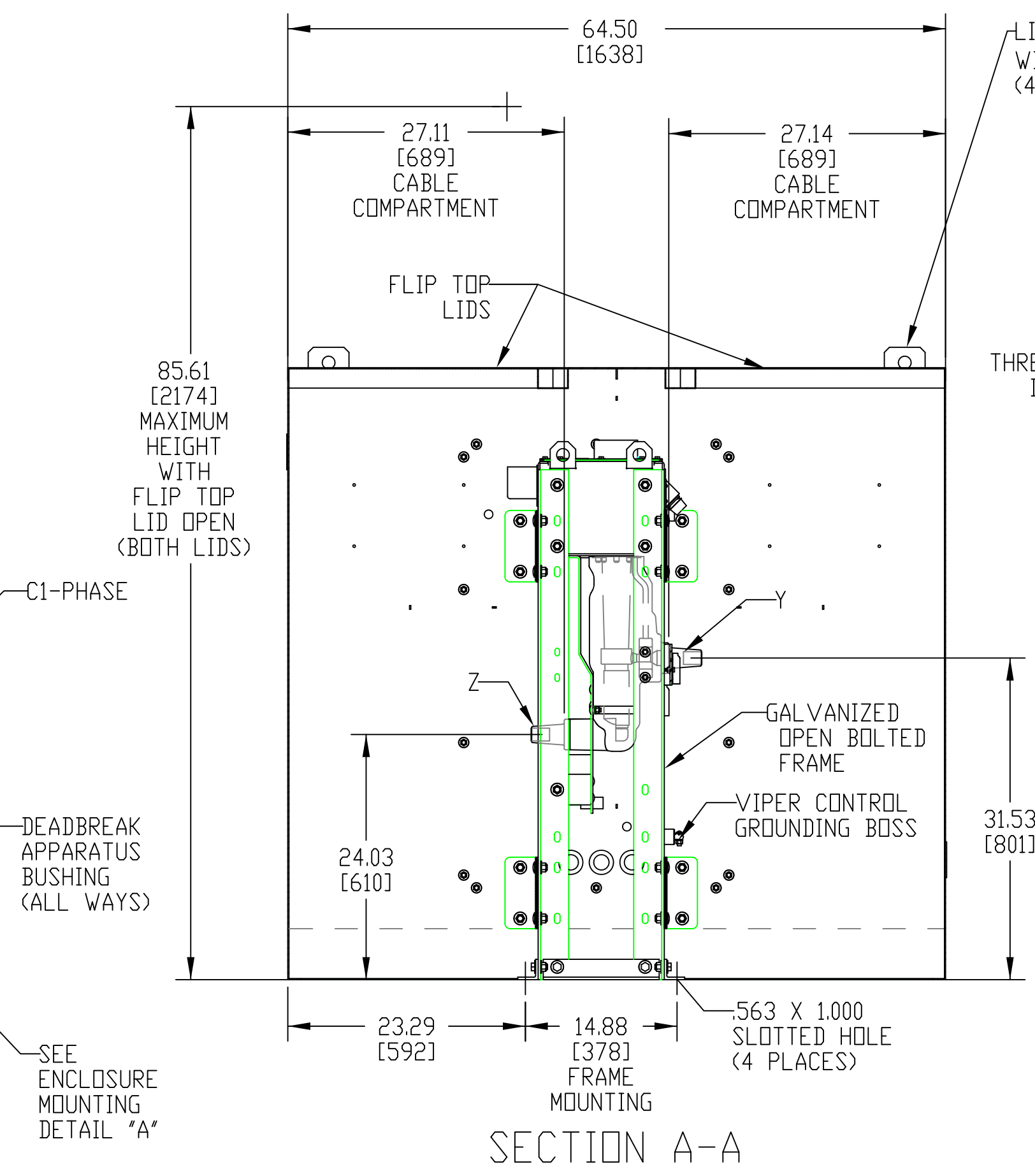
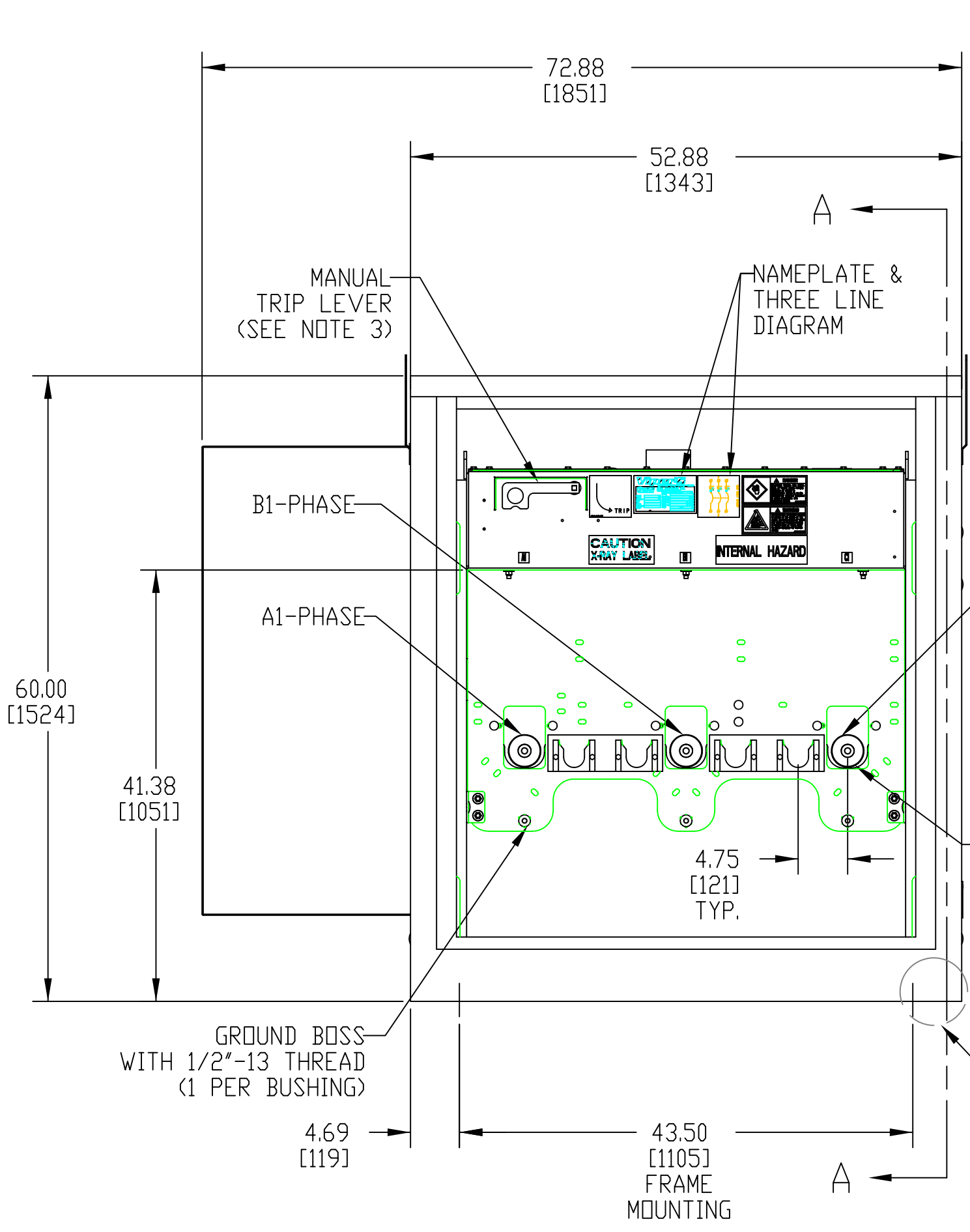

RECLOSER ELECTRICAL INFORMATION
 SEE NOTES FOR LIMITATIONS

MAXIMUM DESIGN VOLTAGE	15.5	KV
IMPULSE LEVEL (BIL)	110	KV
AC 1 MIN. WITHSTAND (DRY)	35	KV
DC 15 MIN. WITHSTAND	53	KV
CURRENT CONTINUOUS	800	AMP
CURRENT INTERRUPTING SYM.	12.5	KA
MOMENTARY CURRENT ASYM.	20	KA
MAKING CURRENT ASYM.	20	KA
3 SEC. RATED DURATION OF SHORT CIRCUIT	12.5	KA

THREE LINE DIAGRAM
 IN SERVICE WEIGHT APPROX. 1400 LBS / 636 KG
 SHIPPING WEIGHT APPROX. 1600 LBS / 727 KG

WAY	ENTRANCES
Y	15.5KV 110KV BIL 800A DEADBREAK APPARATUS BUSHING PER IEEE 386 FIGURE 11
Z	15.5KV 110KV BIL 800A DEADBREAK APPARATUS BUSHING PER IEEE 386 FIGURE 11

- NOTES:**
- 304/304L STAINLESS STEEL MECHANISM HOUSING PAINTED ASA 70 LIGHT GRAY PER G & W SPEC 223.011-82.
 - WHEN ELBOWS, INSERTS, AND ANY OTHER ACCESSORIES ARE CONNECTED TO THE RECLOSER, THE RATINGS OF EACH CONNECTED ASSEMBLY WILL BE THAT OF THE LOWEST RATED COMPONENT OF THE ASSEMBLY.
 - MANUAL TRIP LEVER IS EQUIPPED WITH MECHANICAL AND ELECTRICAL LOCKOUT OF CLOSING CIRCUIT WHEN LEVER IS IN THE TRIPPED POSITION.
 - GALVANIZED STEEL ENCLOSURE FINISHED PADMOUNT GREEN MUNSSELL 7GY329/15. ENCLOSURE IS DESIGNED PER APPLICABLE SECTIONS OF ANSI/IEEE C37.74 AND C57.12.28. DRAWING IS TYPICAL AND SHOWS OVERALL DIMENSIONS ONLY. CONSTRUCTION DETAILS MAY VARY FROM THOSE DEPICTED.
 - 800A APPARATUS BUSHINGS ARE SUITABLE FOR USE WITH 600A OR 900A RATED ELBOWS.
 - RECLOSER IS EQUIPPED WITH A 1000/500:1 CURRENT TRANSFORMER ON EACH PHASE FACTORY SET AT 1000:1 RATIO. REFER TO INSTALLATION, OPERATION AND MAINTENANCE INSTRUCTIONS FOR CHANGING CURRENT TRANSFORMER RATIO IN THE FIELD.
 - MOUNTING INFORMATION: THE FRAME OF THE RECLOSER MUST BE ANCHORED TO THE PAD. THE FRAME IS EQUIPPED WITH (4) SLOTTED ANCHORING HOLES, EACH MEASURING 9/16" X 1". THE LOCATIONS OF THESE HOLES, REFERRED TO AS "FRAME MOUNTING" ARE SHOWN IN THE FRONT VIEW AND SECTION A-A. THE PAD MOUNT ENCLOSURE SHOULD BE SECURED TO THE PAD TO PROVIDE IT WITH ADDITIONAL STABILITY. EACH PAD MOUNT ENCLOSURE IS SHIPPED WITH 4 SECURING BRACKETS THAT ARE TO BE USED FOR THIS PURPOSE. THE SECURING BRACKETS CAN BE INSTALLED ANYWHERE ALONG THE INNER EDGE OF THE ENCLOSURE. SEE ENCLOSURE MOUNTING DETAIL "A" AND THE PLAN VIEW FOR MORE DETAILS ABOUT SECURING THE PAD MOUNT ENCLOSURE TO THE PAD.

RECLOSER SPECIFICS:

- RECLOSER IS EQUIPPED WITH A CONTROL: SEL351R41281X15XA21
- CONTROL CABLE LENGTH IS 10 FT.
- AC CABLE LENGTH IS 10 FT.
- AC CABLE HAS 2 CONNECTOR(S).
- RECLOSER INPUT VOLTAGE AND HEATERS 120VAC.
- CT RATIO FACTORY SET AT 1000:1 RATIO

PRINT IDENTIFICATION

DATE _____ G&W NO. _____

CUSTOMER _____

ORDER NO. _____

FOR RECORD ITEM NO. _____

FOR APPROVAL-NO MORE WORK TO BE DONE UNTIL APPROVAL IS RECEIVED CT RATIO 1000:1

CONTROLLER NO. SEL351R41281X15XA21

DC/DC OPTION USES OUTPUT _____

* ALL PRIMARY DIMENSIONS ARE IN INCHES.
 ALL SECONDARY DIMENSIONS ARE IN MILLIMETERS.

ALL DRAWING CHANGES MUST BE MADE ON CAD. ANY MANUAL CHANGES WILL VOID DRAWING.

PME-VIP378ER-12S

15.5KV 800 AMP PAD STYLE SOLID DIELECTRIC RECLOSER

G&W
 G&W ELECTRIC Co.

DWG. NO. PME-VIP378ER-12S	DRAWING NO. D3670 PM1Z X00	REV. A
ENGR/DES. CL	DATE: Jul-26-16	
APPR BY: AD	DATE: Jul-26-16	SCALE: SHEET 1 of 1

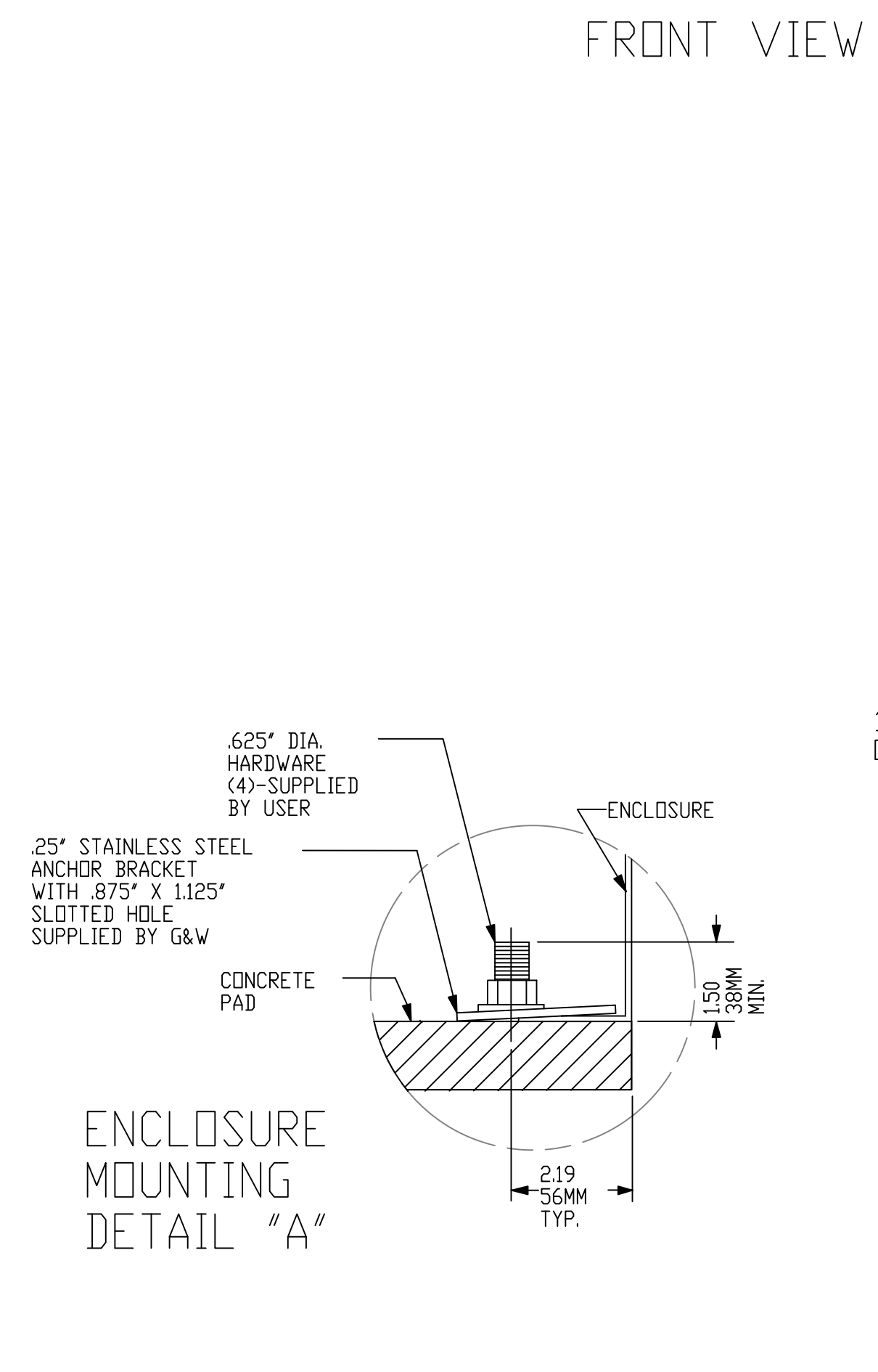

Method of Award: Items/Project will be awarded as a total bid.

Complete and Check All Math: It is the responsibility of the Bidder to extend bid prices and supply a total for all items. It is certified that this proposal is made in good faith and without collusion or connection with any other person bidding on the same above listed items. It is also certified that this proposal is made in good faith and without collusion or connection with any GUC employee(s).

The Undersigned Bidder: hereby declares that it has carefully examined the enclosed detailed specifications for furnishing GUC with the below listed items. The undersigned bidder further agrees, if this proposal is accepted within thirty (30) days from the date of the opening, to furnish any or all of the items upon the quoted price.

[Balance of page left blank intentionally]

It is certified that this proposal is made in good faith and without collusion or connection with any other person bidding on the same above listed items. It is also certified that this proposal is made in good faith and without collusion or connection with any GUC employee(s).

Each Proposal shall be accompanied by cash, cashier's check, or certified check drawn on a bank insured with the Federal Deposit Insurance Corporation or the Savings Association Insurance Fund, payable to the Owner, in an amount not less than five percent (5%) of the total bid as a guarantee that a Purchase Order, if awarded, will be accepted. In lieu thereof, a Bid Bond may be submitted by the Bidder in an amount not less than five percent (5%) of the total bid (see attached Bid Bond form). The total bid price for which the five percent (5%) applies shall be the total of all schedules.

Certified check or cash for \$ _____ or bid bond for \$ _____ attached.

Firm Name _____ Phone (_____) _____

Address _____

City _____ State _____ Zip Code _____

Fax (_____) _____ E-Mail _____

Authorized Official _____ Title _____
Typed Name

_____ Date _____
Signature

GUC Construction Guidelines and Affidavits \$100,000 and Above

Attach to Bid Attach to Bid Attach to Bid Attach to Bid Attach to Bid Attach to Bid Attach to Bid Attach to Bid

Special Instructions to Bidders

**City of Greenville/Greenville Utilities Commission
Minority and/or Women Business Enterprise (M/WBE) Program**

**GUC
Construction Guidelines and Affidavits
\$100,000 and above**

These instructions shall be included with each bid solicitation.

**City of Greenville/Greenville Utilities Commission
Minority and/or Women Business Enterprise Program**

\$100,000 and Construction Guidelines for M/WBE Participants

Policy Statement

It is the policy of the City of Greenville and Greenville Utilities Commission to provide minorities and women equal opportunity for participating in all aspects of the City's and Utilities' contracting and procurement programs, including but not limited to, construction projects, supplies and materials purchases, and professional and personal service contracts.

Goals and Good Faith Efforts

Bidders responding to this solicitation shall comply with the M/WBE program by making Good Faith Efforts to achieve the following aspiration goals for participation.

	GUC	
	MBE	WBE
Construction This goal includes Construction Manager at Risk.	7%	4%

Bidders shall submit M/WBE information with their bids on the forms provided. This information will be subject to verification by GUC prior to contract award. As of July 1, 2009, contractors, subcontractors, suppliers, service providers, or M/WBE members of joint ventures intended to satisfy GUC M/WBE goals shall be certified by the NC Office of Historically Underutilized Businesses (NC HUB) only. Firms qualifying as "WBE" for GUC's goals must be designated as a "women-owned business" by the HUB Office. Firms qualifying as "MBE" for the GUC's goals must be certified in one of the other categories (i.e.: Black, Hispanic, Asian American, American Indian, Disabled, or Socially and Economically Disadvantaged). Those firms who are certified as both a "WBE" and "MBE" may only satisfy the "MBE" requirement. A complete database of NC HUB certified firms may be found at <http://www.doa.nc.gov/hub/>. An internal database of firms who have expressed interest to do business with the City and GUC is available at www.greenvillencmwbe.org. However, the HUB status of these firms must be verified by the HUB database. GUC shall accept NCDOT certified firms on federally funded projects only. Please note: A contractor may utilize any firm desired. However, for participation purposes, all M/WBE vendors who wish to do business as a minority or a female must be certified by NC HUB.

The Bidder shall make good faith efforts to encourage participation of M/WBEs prior to submission of bids in order to be considered as a responsive bidder. Bidders are cautioned that even though their submittal indicates they will meet the M/WBE goal, they should document their good faith efforts and be prepared to submit this information, if requested.

The M/WBE's listed by the Contractor on the **Identification of Minority/Women Business Participation** which are determined by the GUC to be certified shall perform the work and supply the materials for which they are listed unless the Contractors receive prior authorization from the GUC to perform the work with other forces or to obtain materials from other sources. If a contractor is proposing to perform all elements of the work with his own forces, he must be prepared to document evidence satisfactory to the owner of similar government contracts where he has self-performed.

The Contractor shall enter into and supply copies of fully executed subcontracts with each M/WBE or supply signed Letter(s) of Intent to the Project Manager after award of contract and prior to Notice to Proceed. Any amendments to subcontracts shall be submitted to the Project Manager prior to execution.

MBForms 2002-
Revised July 2010

Instructions

The Bidder shall provide with the bid the following documentation:

- Identification of Minority/Women Business Participation
(if participation is zero, please mark zero—Blank forms will be considered nonresponsive)
- Affidavit A (if subcontracting)

OR

- Identification of Minority/Women Business Participation
(if participation is zero, please mark zero—Blank forms will be considered nonresponsive)
- Affidavit B (if self-performing; must attest that bidder does not customarily subcontract work on this type of project—includes supplies and materials)

Within 72 hours or 3 business days after notification of being the apparent low bidder who is subcontracting anything must provide the following information:

- Affidavit C (if aspirational goals are met or are exceeded)

OR

- Affidavit D (if aspirational goals are not met)

After award of contract and prior to issuance of notice to proceed:

- Letter(s) of Intent or Executed Contracts

****With each pay request, the prime contractors will submit the Proof of Payment Certification, listing payments made to M/WBE subcontractors.**

*****If a change is needed in M/WBE Participation, submit a Request to Change M/WBE Participation Form. Good Faith Efforts to substitute with another M/WBE contractor must be demonstrated.**

Minimum Compliance Requirements:

All written statements, affidavits, or intentions made by the Bidder shall become a part of the agreement between the Contractor and the GUC for performance of contracts. Failure to comply with any of these statements, affidavits or intentions or with the minority business guidelines shall constitute a breach of the contract. A finding by the GUC that any information submitted (either prior to award of the contract or during the performance of the contract) is inaccurate, false, or incomplete, shall also constitute a breach of the contract. Any such breach may result in termination of the contract in accordance with the termination provisions contained in the contract. It shall be solely at the option of the GUC whether to terminate the contract for breach or not. In determining whether a contractor has made Good Faith Efforts, the GUC will evaluate all efforts made by the Contractor and will determine compliance in regard to quantity, intensity, and results of these efforts.

Identification of Minority/Women Business Participation

I, _____, (Name of Bidder)

do hereby certify that on this project, we will use the following minority/women business enterprises as construction subcontractors, vendors, suppliers or providers of professional services.

Firm Name, Address and Phone #	Work type	*M/WBE Category

*M/WBE categories: Black, African American (B), Hispanic, Latino (L), Asian American (A) American Indian (I), Female (F) Socially and Economically Disadvantaged (S) Disabled (D)

If you will not be utilizing M/WBE contractors, please certify by entering zero "0"

The total value of MBE business contracting will be (\$)_____.

The total value of WBE business contracting will be (\$)_____.

Greenville Utilities Commission **AFFIDAVIT A – Listing of Good Faith Efforts**

County of _____

(Name of Bidder)

Affidavit of _____

I have made a good faith effort to comply under the following areas checked:

Bidders must earn at least 50 points from the good faith efforts listed for their bid to be considered responsive. (1 NC Administrative Code 30 I.0101)

- 1 – (10 pts)** Contacted minority businesses that reasonably could have been expected to submit a quote and that were known to the contractor, or available on State or local government maintained lists, at least 10 days before the bid date and notified them of the nature and scope of the work to be performed.
- 2 --(10 pts)** Made the construction plans, specifications and requirements available for review by prospective minority businesses, or providing these documents to them at least 10 days before the bids are due.
- 3 – (15 pts)** Broken down or combined elements of work into economically feasible units to facilitate minority participation.
- 4 – (10 pts)** Worked with minority trade, community, or contractor organizations identified by the Office of Historically Underutilized Businesses and included in the bid documents that provide assistance in recruitment of minority businesses.
- 5 – (10 pts)** Attended prebid meetings scheduled by the public owner.
- 6 – (20 pts)** Provided assistance in getting required bonding or insurance or provided alternatives to bonding or insurance for subcontractors.
- 7 – (15 pts)** Negotiated in good faith with interested minority businesses and did not reject them as unqualified without sound reasons based on their capabilities. Any rejection of a minority business based on lack of qualification should have the reasons documented in writing.
- 8 – (25 pts)** Provided assistance to an otherwise qualified minority business in need of equipment, loan capital, lines of credit, or joint pay agreements to secure loans, supplies, or letters of credit, including waiving credit that is ordinarily required. Assisted minority businesses in obtaining the same unit pricing with the bidder's suppliers in order to help minority businesses in establishing credit.
- 9 – (20 pts)** Negotiated joint venture and partnership arrangements with minority businesses in order to increase opportunities for minority business participation on a public construction or repair project when possible.
- 10 - (20 pts)** Provided quick pay agreements and policies to enable minority contractors and suppliers to meet cash-flow demands.

The undersigned, if apparent low bidder, will enter into a formal agreement with the firms listed in the Identification of Minority/Women Business Participation schedule conditional upon scope of contract to be executed with the Owner. Substitution of contractors must be in accordance with GS143-128.2(d) Failure to abide by this statutory provision will constitute a breach of the contract.

The undersigned hereby certifies that he or she has read the terms of the minority/women business commitment and is authorized to bind the bidder to the commitment herein set forth.

Date: _____ Name of Authorized Officer: _____

Signature: _____

Title: _____



State of _____, County of _____

Subscribed and sworn to before me this _____ day of _____ 20____

Notary Public _____

My commission expires _____

Greenville Utilities Commission --AFFIDAVIT B-- Intent to Perform Contract with Own Workforce.

County of _____

Affidavit of _____
(Name of Bidder)

I hereby certify that it is our intent to perform 100% of the work required for the _____
_____ contract.
(Name of Project)

In making this certification, the Bidder states that the Bidder does not customarily subcontract elements of this type project, and normally performs and has the capability to perform and will perform all elements of the work on this project with his/her own current work forces; and

The Bidder agrees to provide any additional information or documentation requested by the owner in support of the above statement.

The undersigned hereby certifies that he or she has read this certification and is authorized to bind the Bidder to the commitments herein contained.

Date: _____ Name of Authorized Officer: _____

Signature: _____

Title: _____



State of _____, County of _____

Subscribed and sworn to before me this _____ day of _____ 20__

Notary Public _____

My commission expires _____

Do not submit with bid Do not submit with bid Do not submit with bid Do not submit with bid

Greenville Utilities Commission - AFFIDAVIT C - Portion of the Work to be Performed by M/WBE Firms

County of _____

(Note this form is to be submitted only by the apparent lowest responsible, responsive bidder.)

If the portion of the work to be executed by M/WBE businesses as defined in GS143-128.2(g) and the COG/GUC M/WBE Plan sec. III is equal to or greater than 11% of the bidders total contract price, then the bidder must complete this affidavit. This affidavit shall be provided by the apparent lowest responsible, responsive bidder within **72 hours** after notification of being low bidder.

Affidavit of _____ I do hereby certify that on the _____
(Name of Bidder)

Project ID# _____ (Project Name) Amount of Bid \$ _____

I will expend a minimum of _____% of the total dollar amount of the contract with minority business enterprises and a minimum of _____% of the total dollar amount of the contract with women business enterprises. Minority/women businesses will be employed as construction subcontractors, vendors, suppliers or providers of professional services. Such work will be subcontracted to the following firms listed below. Attach additional sheets if required

Name and Phone Number	*M/WBE Category	Work description	Dollar Value

*Minority categories: Black, African American (B), Hispanic or Latino (L), Asian American (A) American Indian (I), Female (F) Socially and Economically Disadvantaged (S) Disabled (D)

Pursuant to GS143-128.2(d), the undersigned will enter into a formal agreement with M/WBE Firms for work listed in this schedule conditional upon execution of a contract with the Owner. Failure to fulfill this commitment may constitute a breach of the contract.

The undersigned hereby certifies that he or she has read the terms of this commitment and is authorized to bind the bidder to the commitment herein set forth.

Date: _____ Name of Authorized Officer: _____

Signature: _____

Title: _____



State of _____, County of _____

Subscribed and sworn to before me this _____ day of _____ 20____

Notary Public _____

My commission expires _____

Greenville Utilities Commission AFFIDAVIT D – Good Faith Efforts

County of _____

(Note this form is to be submitted only by the apparent lowest responsible, responsive bidder.)

If the goal of 11% participation by minority/women business **is not** achieved, the Bidder shall provide the following documentation to the Owner of his good faith efforts:

Affidavit of _____ I do hereby certify
that on the _____

(Name of Bidder)

Project ID# _____ (Project Name) _____
Amount of Bid \$ _____

I will expend a minimum of _____% of the total dollar amount of the contract with minority business enterprises and a minimum of _____% of the total dollar amount of the contract with women business enterprises. Minority/women businesses will be employed as construction subcontractors, vendors, suppliers or providers of professional services. Such work will be subcontracted to the following firms listed below. (Attach additional sheets if required)

Name and Phone Number	*M/WBE Category	Work description	Dollar Value

*Minority categories: Black, African American (B), Hispanic or Latino (L), Asian American (A) American Indian (I), Female (F) Socially and Economically Disadvantaged (S) Disabled (D)

Examples of documentation required to demonstrate the Bidder's good faith efforts to meet the goals set forth in these provisions include, but are not necessarily limited to, the following:

- A. Copies of solicitations for quotes to at least three (3) minority business firms from the source list provided by the State for each subcontract to be let under this contract (if 3 or more firms are shown on the source list). Each solicitation shall contain a specific description of the work to be subcontracted, location where bid documents can be reviewed, representative of the Prime Bidder to contact, and location, date and time when quotes must be received.
- B. Copies of quotes or responses received from each firm responding to the solicitation.
- C. A telephone log of follow-up calls to each firm sent a solicitation.
- D. For subcontracts where a minority business firm is not considered the lowest responsible sub-bidder, copies of quotes received from all firms submitting quotes for that particular subcontract.
- E. Documentation of any contacts or correspondence to minority business, community, or contractor organizations in an attempt to meet the goal.
- F. Copy of pre-bid roster.
- G. Letter documenting efforts to provide assistance in obtaining required bonding or insurance for minority business.
- H. Letter detailing reasons for rejection of minority business due to lack of qualification.
- I. Letter documenting proposed assistance offered to minority business in need of equipment, loan capital, lines of credit, or joint pay agreements to secure loans, supplies, or letter of credit, including waiving credit that is ordinarily required.

Failure to provide the documentation as listed in these provisions may result in rejection of the bid and award to the next lowest responsible and responsive bidder.

Do not submit with the bid Do not submit with the bid Do not submit with the bid Do not submit with the bid

Pursuant to GS143-128.2(d), the undersigned will enter into a formal agreement with M/WBE Firms for work listed in this schedule conditional upon execution of a contract with the Owner. Failure to fulfill this commitment may constitute a breach of the contract.

The undersigned hereby certifies that he or she has read the terms of this commitment and is authorized to bind the bidder to the commitment herein set forth.

Date: _____ Name of Authorized Officer: _____

Signature: _____

Title: _____



State of _____, County of _____

Subscribed and sworn to before me this _____ day of _____ 20____

Notary Public _____

My commission expires _____

LETTER OF INTENT M/WBE Subcontractor Performance

Please submit this form or executed subcontracts with M/WBE firms after award of contract and prior to issuance of notice to proceed.

PROJECT: _____
(Project Name)

TO: _____
(Name of Prime Bidder/Architect)

The undersigned intends to perform work in connection with the above project as a:

___ Minority Business Enterprise ___ Women Business Enterprise

The M/WBE status of the undersigned is certified the NC Office of Historically Underutilized Businesses (required). ___ Yes ___ No

The undersigned is prepared to perform the following described work or provide materials or services in connection with the above project at the following dollar amount:

Work/Materials/Service Provided	Dollar Amount of Contract	Projected Start Date	Projected End Date

(Date)

(Address)

(Name & Phone No. of M/WBE Firm)

(Name & Title of Authorized Representative of M/WBE)

(Signature of Authorized Representative of M/WBE)

REQUEST TO CHANGE M/WBE PARTICIPATION

(Submit changes only if notified as apparent lowest bidder, continuing through project completion)

Project: _____

Bidder or Prime Contractor: _____

Name & Title of Authorized Representative: _____

Address: _____ **Phone #:** _____

_____ **Email Address:** _____

Total Contract Amount (including approved change orders or amendments): \$ _____

Name of subcontractor: _____

Good or service provided: _____

Proposed Action:

Replace subcontractor

Perform work with own forces

For the above actions, you must provide one of the following reasons (Please check applicable reason):

The listed MBE/WBE, after having had a reasonable opportunity to do so, fails or refuses to execute a written contract.

The listed MBE/WBE is bankrupt or insolvent.

The listed MBE/WBE fails or refuses to perform his/her subcontract or furnish the listed materials.

The work performed by the listed subcontractor is unsatisfactory according to industry standards and is not in accordance with the plans and specifications; or the subcontractor is substantially delaying or disrupting the progress of the work.

If replacing subcontractor:

Name of replacement subcontractor: _____

The M/WBE status of the contractor is certified by the NC Office of Historically Underutilized Businesses (required). Yes No

Dollar amount of original contract \$ _____

Dollar amount of amended contract \$ _____

Other Proposed Action:

Increase total dollar amount of work
 Decrease total dollar amount of work

Add additional subcontractor
 Other

Please describe reason for requested action: _____

If adding additional subcontractor:*

The M/WBE status of the contractor is certified by the NC Office of Historically Underutilized Businesses (required). Yes No

**Please attach Letter of Intent or executed contract document*

Dollar amount of original contract \$ _____

Dollar amount of amended contract \$ _____

Interoffice Use Only:

Approval Y N

Date _____

Signature _____

Do not submit with the bid Do not submit with the bid Do not submit with the bid Do not submit with the bid

Pay Application No. _____ Purchase Order No. _____

Proof of Payment Certification

M/WBE Contractors, Suppliers, Service Providers

Project Name: _____

Prime Contractor: _____

Current Contract Amount (including change orders): \$ _____

Requested Payment Amount for this Period: \$ _____

Is this the final payment? ___ Yes ___ No

Firm Name	M/WBE Category*	Total Amount Paid from this Pay Request	Total Contract Amount (including changes)	Total Amount Remaining

*Minority categories: Black, African American (B), Hispanic or Latino (L), Asian American (A) American Indian (I), Female (F) Socially and Economically Disadvantaged (S) Disabled (D)

Date: _____ Certified By: _____

Name

Title

Signature

**Three (3) copies of your proposal should be received no later than
November 18, 2021at 3:00 PM (EDST).**

**NO BIDS CONSIDERED UNLESS SUBMITTED ON THIS FORM(S) RETURN BID
SECURITY, THIS FORM, COST FORM(S), EXCEPTION FORM(S), E-VERIFY FORM AND
ALL PROPOSAL AND PRICING FORM(S)**

[Balance of page left blank intentionally]

GREENVILLE UTILITIES COMMISSION

EXCEPTION/VARIATION FORM FOR:

800 kW PEAK SHAVING GENERATION SYSTEM

NOVEMBER 18, 2021

Provider's Certification: This is to certify that it is our intent to furnish equipment, material, services, etc. in absolute compliance with the bid specification except where expressly noted below.

Instructions: List all exceptions or variations to these bid specifications. Providers shall identify each exception or variation by specification page. The omission of exception or variation information shall be deemed by the Commission as the Provider's intent to absolutely comply with the bid specification. If additional space is required, Provider may reproduce this form as necessary.

<u>Page #</u>	<u>Exception/Variation</u>
_____	_____
_____	_____
_____	_____
_____	_____
_____	_____
_____	_____
_____	_____
_____	_____
_____	_____
_____	_____
_____	_____

Authorized Signature of Certification: _____

Print Name: _____

Firm Represented: _____

Address: _____

Letter of Compliance to E-Verify for Greenville Utilities Commission

1. I have submitted a bid for contract or desire to enter into a contract with the Greenville Utilities Commission;
2. As part of my duties and responsibilities pursuant to said bid and/or contract, I affirm that I am aware of and in compliance with the requirements of E-Verify, Article 2 of Chapter 64 of the North Carolina General Statutes, to include (mark which applies):

3. ____ After hiring an employee to work in the United States I verify the work authorization of said employee through E-Verify and retain the record of the verification of work authorization while the employee is employed and for one year thereafter; or
4. ____ I employ less than fifteen (15) employees in the State of North Carolina.

5. As part of my duties and responsibilities pursuant to said bid and/or contract, I affirm that to the best of my knowledge and subcontractors employed as a part of this bid and/or contract, are in compliance with the requirements of E-Verify, Article 2 of Chapter 64 of the North Carolina General Statutes, to include (mark which applies):

6. ____ After hiring an employee to work in the United States the subcontractor verifies the work authorization of said employee through E-Verify and retains the record of the verification of work authorization while the employee is employed and for one year thereafter; or
7. ____ Employ less than fifteen (15) employees in the State of North Carolina.

Specify subcontractor: _____

_____ (Company Name)

By: _____ (Typed Name)

_____ (Authorized Signatory)

_____ (Title)

_____ (Date)

SECTION III

TERMS AND CONDITIONS FOR THE PURCHASE OF APPARATUS, SUPPLIES, MATERIALS, EQUIPMENT, LABOR AND BUILD

These Terms and Conditions, made and entered into on this the _____ day of _____, by and between GREENVILLE UTILITIES COMMISSION OF THE CITY OF GREENVILLE, PITT COUNTY, NORTH CAROLINA, with one of its principal offices and places of business at 401 S. Greene Street, Post Office Box 1847, Greenville, Pitt County, North Carolina 27835-1847, hereinafter referred to as "GUC" and _____, a _____ organized and existing under and by virtue of the laws of the State of _____, with one of its principal offices and places of business at _____, hereinafter referred to as "PROVIDER";

1.0 TAXES

No taxes shall be included in any bid prices. GUC is exempt from Federal Excise Tax. GUC is not exempt from North Carolina state sales and use tax or, if applicable, Pitt County sales and use tax. Such taxes shall be shown as a separate item on the invoice.

2.0 INVOICES

It is understood and agreed that orders will be shipped at the established contract prices and quantities in effect on dates orders are placed. Invoicing at variance with this provision may subject the contract to cancellation. Applicable North Carolina sales tax shall be invoiced as a separate line item. All invoices must bear the GUC purchase order number. Mail all invoices to Greenville Utilities Commission, Finance Department, P. O. Box 1847, Greenville, NC 27835-1847.

3.0 PAYMENT TERMS

Payments for equipment, materials, or supplies will be made after the receipt and acceptance of the equipment, materials, supplies or services and after submission of a proper invoice. GUC's normal payment policy is thirty (30) days. GUC will not be responsible for any goods delivered without a purchase order having been issued. Payment will be made in U. S. currency only.

4.0 QUANTITIES

Quantities specified are only estimates of GUC's requirements. GUC reserves the right to purchase more or less than the stated quantities at prices indicated in the submitted Proposal Form based on our actual needs.

5.0 AFFIRMATIVE ACTION

The Provider will take affirmative action in complying with all Federal and State requirements concerning fair employment and employment of the handicapped, and concerning the treatment of all employees, without discrimination by reason of race, color, religion, sex, national origin, or physical handicap.

6.0 CONDITION AND PACKAGING

Unless otherwise indicated in the bid, it is understood and agreed that any item offered or shipped shall be new and in first class condition, that all containers shall be new and suitable for storage or shipment, and that prices include standard commercial packaging.

7.0 SAMPLES

Samples of items, if required, must be furnished free of expense to GUC, and if not destroyed, will, upon request, be returned at the Provider's expense. Request for the return of samples must be made at the bid opening, otherwise, the samples will become GUC's property. Each individual sample must be labeled with Provider's name.

8.0 SPECIFICATIONS

Any deviation from specifications must be clearly pointed out, otherwise, it will be considered that items offered are in strict compliance with specifications, and the Provider will be held responsible. Deviations must be explained in detail. **The Provider shall not construe this paragraph as inviting deviation or implying that any deviation will be acceptable.**

9.0 INFORMATION AND DESCRIPTIVE LITERATURE

Providers are to furnish all information requested. Further, as may be specified elsewhere, each Provider must submit with its proposal: cuts, sketches, descriptive literature, and/or complete specifications covering the products offered. Reference to literature submitted with a previous bid does not satisfy this provision. Bids which do not comply with these requirements will be subject to rejection.

10.0 AWARD OF CONTRACT

As directed by statute, qualified bids will be evaluated and acceptance made of the lowest responsible, responsive bid most advantageous to GUC as determined upon consideration of such factors as prices offered, the quality of the article(s) offered, the general reputation and performance capabilities of the Provider, substantial conformity with the specifications and other conditions set forth in the bid, the suitability of the article(s) for the intended use, the related services needed, the date(s) of delivery and performance, and such other factors deemed by GUC to be pertinent or peculiar to the purchase in question.

Acceptance of the order includes acceptance of all terms, conditions, prices, delivery instructions, and specifications as shown on this set of Terms and Conditions and in this order or attached to and made a part of this order.

The conditions of this order cannot be modified except by written amendment in the form of "Amended Purchase Order," which has been approved by GUC's Procurement Manager.

In the event of a Provider's failure to deliver or perform as specified, GUC reserves the right to cancel the order or any part thereof, without prejudice to GUC's other rights. The Provider agrees that GUC may return part of or all of any shipment at Provider's expense. GUC may charge the Provider with all reasonable expenses resulting from such failure to deliver or perform.

11.0 MEDIATION/BINDING ARBITRATION

In the event of any dispute between the Parties, the Parties agree to submit any dispute to non-binding mediation before a mutually agreeable Mediator prior to initiating litigation. If the Parties are unable to agree upon a Mediator within thirty (30) days after demand therefore, either Party may petition a Court of competent jurisdiction for the designation of a qualified Mediator for these purposes. Each Party shall bear its own costs and expenses of participating in the mediation (including, without limitation, reasonable attorneys' fees), and each Party shall bear one-half (1/2) of the costs and expenses of the Mediator. Unless otherwise agreed, the Parties will hold the mediation in Greenville, North Carolina. The matters discussed or revealed in the mediation session shall not be disclosed in any subsequent litigation.

In the event the matter is not resolved in mediation, either Party may request arbitration. The parties shall jointly select an Arbitrator, and shall be bound by the decision of the Arbitrator with respect to any dispute between the parties with respect to this Agreement. If the parties are unable to mutually agree upon an Arbitrator, the Parties shall each select an Arbitrator, and the two Arbitrators so selected shall select a third Arbitrator, and the decision of the majority of the Arbitrators shall be conclusive and binding upon the Parties. The Parties at all times agree to equally split the costs of any Arbitrator(s) selected in an effort to resolve the dispute between the Parties. Any party desiring to resolve a dispute under the terms of this Agreement shall notify the other Party in writing, and the Parties shall seek to agree upon a mutually agreed-upon Arbitrator within a period of ten (10) days from the date of such written demand. If the Parties are unable to agree within such ten (10) day period, the Parties shall each select an Arbitrator, and the two (2) Arbitrators so selected shall select a third Arbitrator within fifteen (15) days from the date of the written demand for arbitration, and a decision shall be rendered by the Arbitrator(s) so selected within five (5) days after such Arbitrator(s) is selected.

12.0 GOVERNMENT RESTRICTIONS

In the event any Governmental restrictions may be imposed which would necessitate alteration of the material, quality, workmanship, or performance of the items offered on this bid prior to their delivery, it shall be the responsibility of the successful Provider to notify the GUC Procurement Manager, at once, indicating in its letter the specific regulation which required such alterations. GUC reserves the right to accept any such alterations, including any price adjustments occasioned thereby, or, in the sole discretion of GUC, to cancel the contract.

13.0 INSURANCE

13.1 Coverage – During the term of the contract, the Provider at its sole cost and expense shall provide commercial insurance of such type and with the following coverage and limits:

13.1.1 Workers' Compensation – The Provider shall provide and maintain Workers' Compensation Insurance, as required by the laws of North Carolina, as well as employer's liability coverage with minimum limits of \$1,000,000 each accident, covering all Provider's employees who are engaged in any work under the contract. If any work is sublet, the Provider shall require the subcontractor to provide the same coverage for any of its employees engaged in any work under the contract.

13.1.2 General Liability – Commercial Liability Coverage written on an "occurrence" basis in the minimum amount of \$1,000,000 per occurrence.

13.1.3 Automobile – Automobile Liability Insurance, to include coverage for all owned, hired, and non-owned vehicles used in connection with the contract with a minimum combined single limit of \$1,000,000 per accident.

13.2 Requirements - Providing and maintaining adequate insurance coverage is a material obligation of the Provider. All such insurance shall meet all laws of the State of North Carolina. Such insurance coverage shall be obtained from companies that are authorized to provide such coverage and that are authorized to do business in North Carolina by the Commissioner of Insurance. The Provider shall at all times comply with the terms of such insurance policies and all requirements of the insurer under any of such insurance policies, except as they may conflict with existing North Carolina laws or this contract. The limits of coverage under each insurance policy maintained by the Provider shall not be interpreted as limiting the Provider's liability and obligations under the contract. It is agreed that the coverage as stated shall not be canceled or changed until thirty (30) days after written notice of such termination or alteration has been sent by registered mail to GUC's Procurement Manager.

14.0 PATENTS AND COPYRIGHTS

The Provider shall hold and save GUC, its officers, agents, and employees, harmless from liability of any kind, including costs and expenses, including reasonable attorney fees, on account of any copyrighted articles or any patented or unpatented invention, device or appliance manufactured or used in the performance of this contract.

15.0 PATENT AND COPYRIGHT INDEMNITY

The Provider will defend or settle, at its own expense, any action brought against GUC to the extent that it is based on a claim that the product(s) provided pursuant to this agreement infringe any U.S. copyright or patent; and will pay those costs, damages, and attorney fees finally awarded against GUC in any such action attributable to any such claim, but such defense, settlements, and payments are conditioned on the following: (1) that Provider shall be notified promptly in writing by GUC of any such claim; (2) that Provider shall have sole control of the defense of any action on such claim and of all negotiations for its settlement or compromise; (3) that GUC shall cooperate with Provider in a reasonable way to facilitate the settlement of defense of such claim; (4) that such claim does not arise from GUC modifications not authorized by the Provider or from the use of combination of products provided by the Provider with products provided by GUC or by others; and (5) should such product(s) become, or in the Provider's opinion likely to become, the subject of such claim of infringement, then GUC shall permit Provider, at Provider's option and expense, either to procure for GUC the right to continue using the product(s), or replace or modify the same so that it becomes non-infringing and performs in a substantially similar manner to the original product.

16.0 EXCEPTIONS

All proposals are subject to the terms and conditions outlined herein. All responses will be controlled by such terms and conditions and the submission of other terms and conditions, price catalogs, and other documents as part of a Provider's response will be waived and have no effect on this Request for Proposal or any other contract that may be awarded resulting from this solicitation. The submission of any other terms and conditions by a Provider may be grounds for rejection of the Provider's proposal. The Provider specifically agrees to the terms and

conditions set forth in this set of Terms and Conditions by affixing its name on the signatory page contained herein.

17.0 CONFIDENTIAL INFORMATION

Except as provided by statute and rule of law, GUC will keep trade secrets which the Provider does not wish disclosed confidential. Each page shall be identified in boldface at the top and bottom as "CONFIDENTIAL" by the Provider. Cost information shall not be deemed confidential. The determination of whether a matter is confidential will be determined by North Carolina law.

18.0 ASSIGNMENT

No assignment of the Provider's obligations or the Provider's right to receive payment hereunder shall be permitted without the express written consent of GUC, provided however, upon written request approved by the GUC Procurement Manager, solely as a convenience to the Provider, GUC may:

- Forward the Provider's payment check directly to any person or entity designated by the Provider, and
- Include any person or entity designated by Provider as a joint payee on the Provider's payment check.
- In no event shall such approval and action obligate GUC to anyone other than the Provider, and the Provider shall remain responsible for fulfillment of all contract obligations.

19.0 ACCESS TO PERSON AND RECORDS

GUC shall have reasonable access to persons and records of Provider as a result of all contracts entered into by GUC.

20.0 INSPECTION AT BIDDER'S SITE

GUC reserves the right to inspect, at a reasonable time, the item, plant, or other facilities of a prospective Provider prior to contract award and during the contract term as necessary for GUC's determination that such item, plant, or other facilities conform with the specifications/requirements and are adequate and suitable for the proper and effective performance of the contract. Provider may limit GUC's access to restricted areas.

21.0 AVAILABILITY OF FUNDS

Any and all payments of compensation of this specific transaction and any continuation or any renewal or extension are dependent upon and subject to the allocation of GUC funds for the purpose set forth in this Agreement.

22.0 GOVERNING LAWS

All contracts, transactions, agreements, etc., are made under and shall be governed by and construed in accordance with the laws of the State of North Carolina.

23.0 ADMINISTRATIVE CODE

Bids, proposals, and awards are subject to applicable provisions of the North Carolina Administrative Code and General Statutes and Laws of the State of North Carolina.

24.0 EXECUTION

In the discretion of GUC, failure of a duly authorized official of Provider to sign the Signatory Page may render the bid invalid.

25.0 CLARIFICATIONS/INTERPRETATIONS

Any and all questions regarding these Terms and Conditions must be addressed to the GUC Procurement Manager. Do not contact the user directly. **These Terms and Conditions are a complete statement of the parties' agreement and may only be modified in writing signed by Provider and the GUC Procurement Manager.**

26.0 SITUS

The place of all contracts, transactions, agreements, their situs and forum, shall be North Carolina, where all matters, whether in contract or tort, relating to the validity, construction, interpretation, and enforcement shall be determined.

27.0 TERMINATION OF AGREEMENT

GUC or Provider may terminate this Agreement for just cause at any time. Provider will be paid for all time and expenses incurred as of the termination date. Termination for just cause by either party shall be by certified letter and shall be effective thirty (30) days after signed and acknowledged receipt of said letter. Just cause shall be based on reasonable grounds, and there must be a fair and honest cause or reason for such action. The causes for termination, include, but are not limited to: (1) Provider's persistent failure to perform in accordance with the Terms and Conditions, (2) Provider's disregard of laws and regulations related to this transaction, and/or (3) Provider's substantial violation of the provisions of the Terms and Conditions.

28.0 DELIVERY

Shipments will be made only upon releases from a purchase order issued by GUC in accordance with GUC's current needs.

Time is of the essence with respect to all deliveries under this Agreement. Delivery of all equipment, materials, or supplies shall be made Free on Board (FOB) GUC Warehouse, 701 Utility Way, Greenville, North Carolina 27834, **unless otherwise specified.** The agreed price for such equipment, materials, or supplies shall include all costs of delivery and ownership, and risks of loss shall not be transferred from Provider to GUC until express written acceptance of delivery and inspection by GUC. Delivery hours are between 8:00 AM and 4:30 PM Monday-Friday only. **GUC's purchase order number is to be shown on the packing slip or any related documents.** GUC reserves the right to refuse or return any delivery with no purchase order number or which is damaged. GUC will not be charged a restocking fee for any delivery which is refused or returned.

29.0 INDEMNITY PROVISION

Provider agrees to indemnify and save GREENVILLE UTILITIES COMMISSION of the City of Greenville, Pitt County, North Carolina, and the City of Greenville, North Carolina, its co-owners, joint venturers, agents, employees, and insurance carriers harmless from any and all losses, claims, actions, costs, expenses including reasonable attorney fees, judgments, subrogations, or other damages resulting from injury to any person (including injury resulting in death), or damage (including loss or destruction) to property of whatsoever nature of any person arising out of or incident to the performance of the terms of this Contract by Provider, including, but not limited to, Provider's employees, agents, subcontractors, and others designated by Provider to perform work or services in, about, or attendant to, the work and services under the terms of this Contract. Provider shall not be held responsible for any losses, expenses, claims, subrogations, actions, costs, judgments, or other damages, directly, solely, and proximately caused by the negligence of Greenville Utilities Commission of the City of Greenville, Pitt County, North Carolina. Insurance covering this indemnity agreement by the Provider in favor of Greenville Utilities Commission of the City of Greenville, Pitt County, North Carolina, and the City of Greenville, North Carolina, shall be provided by Provider.

30.0 FORCE MAJEURE

Neither party shall be considered in default in the performance of its obligations hereunder to the extent that the performance of any such obligation is prevented or delayed by any cause, existing or future, which is beyond the reasonable control of such party. In any such event of force majeure, the parties shall advise each other of such event, and the parties shall negotiate an equitable adjustment to their respective obligations under this Agreement.

31.0 WARRANTY(IES)

The Provider hereby includes all warranties, whether expressed or implied, including, but not limited to, the Implied Warranty of Merchantability and the Implied Warranty of Fitness for a Particular Purpose.

32.0 INTEGRATED CONTRACT

These Terms and Conditions, Instructions to Bidders, Specifications, and the selected Provider's bid represents the entire contract between the Parties. No verbal or other written agreement(s) shall be held to vary the provisions of this Agreement.

33.0 CONTRACT PROVISIONS

Each of the provisions of these Terms and Conditions shall apply to the full extent permitted by law, and the invalidity in whole or in part of any provision shall not affect the remainder of such provision or any other provisions.

34.0 E-VERIFY

E-Verify - I understand that E-Verify is the federal E-Verify program operated by the United States Department of Homeland Security and other federal agencies, or any successor or equivalent program used to verify the work authorization of newly hired employees pursuant to federal law in accordance with NCGS §64-25 et seq. I am aware of and in compliance with the requirements of E-Verify and Article 2 of Chapter 64 of the North Carolina General Statutes. To the best of my knowledge, any subcontractors employed by me as a part of this contract are in

compliance with the requirements of E-Verify and Article 2 of Chapter 64 of the North Carolina General Statutes.

35.0 IRAN DIVESTMENT ACT CERTIFICATION

By acceptance of this purchase order, Vendor/Contractor certifies that, as of the date of the purchase order or contract, it is not on the Final Divestment List as created by the State Treasurer pursuant to N.C.G.S. § 143-6A-4. In compliance with the requirements of the Iran Divestment Act and N.C.G.S. § 143C-6A-5(b), Vendor/Contractor shall not utilize in the performance of the contract any subcontractor that is identified on the Final Divestment List.

36.0 UNIFORM GUIDANCE

Contracts funded with federal grant or loan funds must be procured in a manner that conforms with all applicable federal laws, policies, and standards, including those under the Uniform Guidance (2 C.F.R. Part 200).

37.0 NOTICES

Notices to the Parties should be sent to the names and addresses specified below:

Cleve Haddock, CLGPO
Procurement Manager
Greenville Utilities Commission
P.O. Box 1847
Greenville, NC 27835-1847

Vendor Specified on Page 1 of Section III when awarded.

[Balance of page left blank intentionally]

GREENVILLE UTILITIES COMMISSION

By: _____
Anthony C. Cannon

Title: General Manager/CEO
(Authorized Signatory)

Date: _____

Attest: _____

Name (Print): Amy Wade

Title: Executive Secretary

Date: _____

(OFFICIAL SEAL)

COMPANY NAME

By: _____

Name (Print): _____

Title: _____
(Authorized Signatory)

Date: _____

Attest: _____

Name (Print): _____

Title: Corporate Secretary

Date: _____

(CORP. SEAL)

This instrument has been pre-audited in the manner required by the Local Government Budget and Fiscal Control Act.

By: _____
Jeff W. McCauley

Title: Chief Financial Officer

Date: _____

APPROVED AS TO FORM AND LEGAL CONTENT:

By: _____
Phillip R. Dixon

Title: General Counsel

Date: _____